

1.1 GENERAL

Toshiba Personal Computer T3100e is a compact and light-weight portable personal computer. The T3100e is a high-performance system with special features. The CPU is the 80286-12 16-bit microprocessor. The standard memory has a capacity of 1 Mbyte. The hard disk drive (HDD) has a capacity of 20 Mbytes. The floppy disk drive (FDD) can support 2DD (720 Kbytes) and 2HD (1.44 Mbytes) floppy disks. The universal auto-sensing power supply is used for world-wide usage.

The T3100e system unit consists of the following functional modules;

- System board/Memory board
- 3.5-inch floppy disk drive
- 3.5-inch hard disk drive
- Plasma display
- Keyboard
- Power supply unit

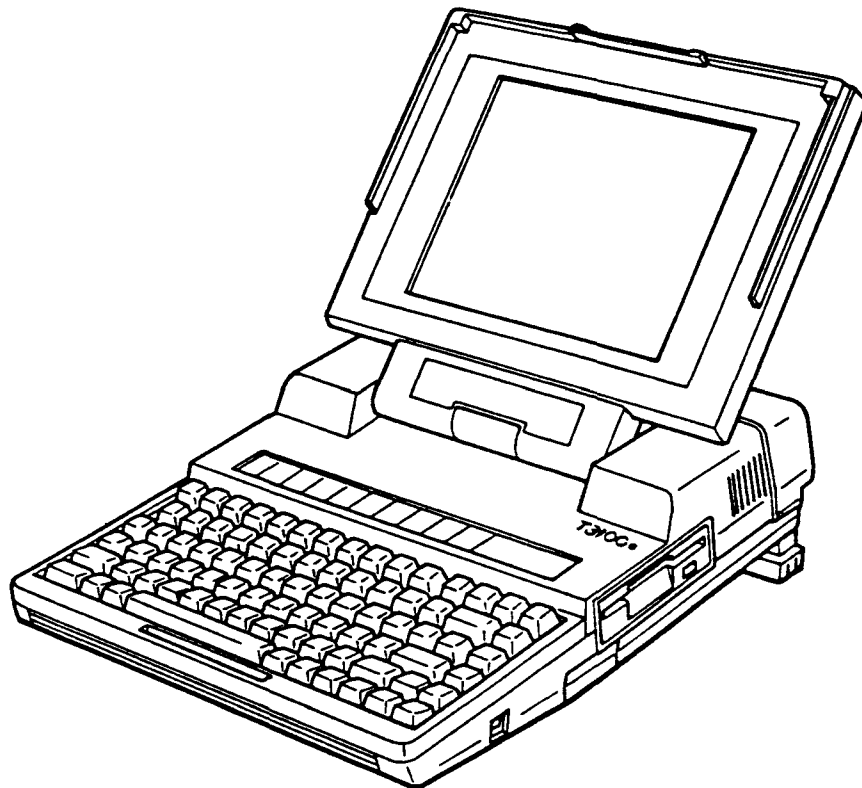

Figure 1-1 T3100e personal computer

1.2 SYSTEM UNIT

The configuration of the system unit is shown in figure 1-2.

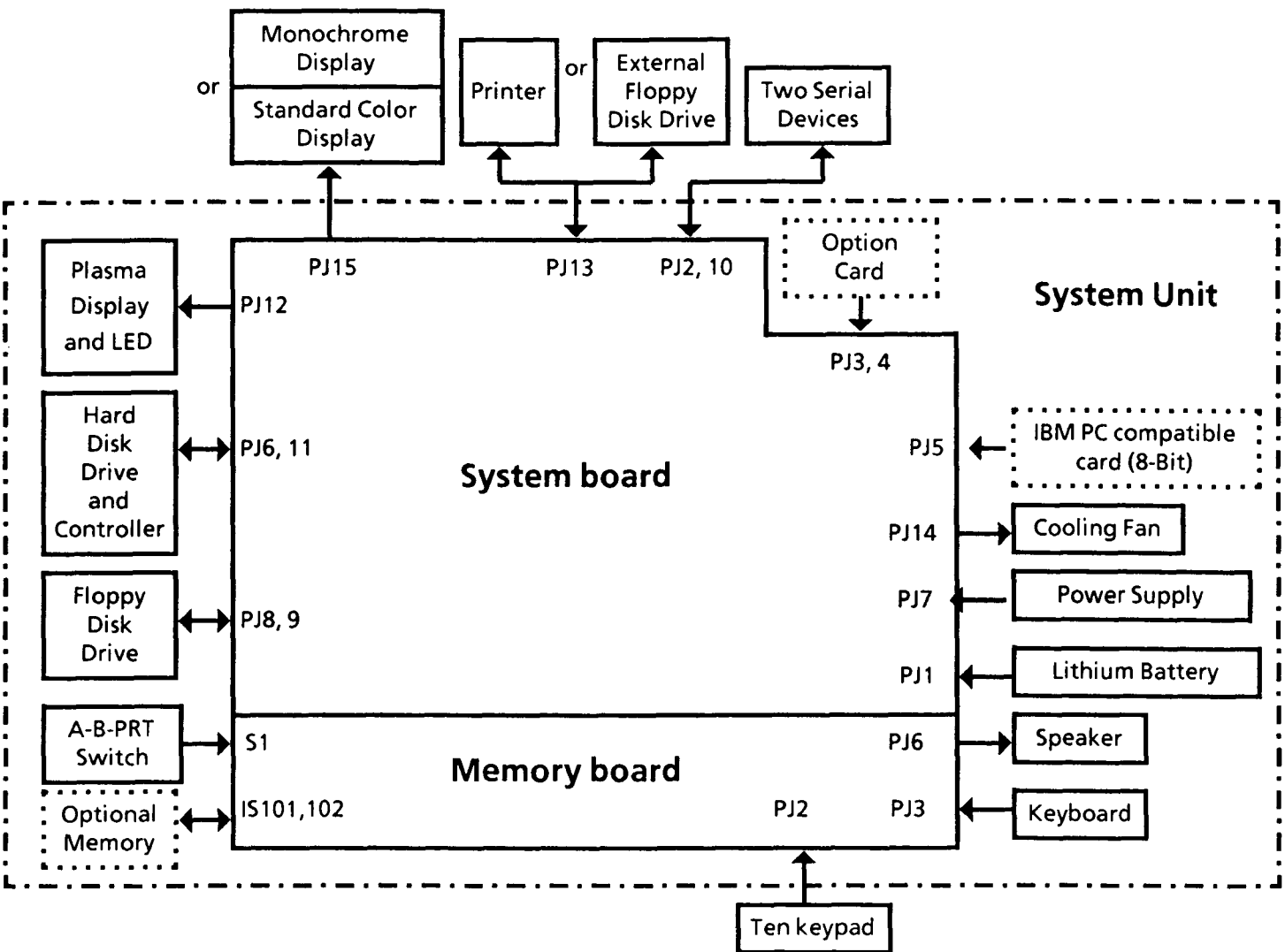

Figure 1-2 System unit configuration

The key features of the system unit are:

- o A system board and memory board connected by 2 flat cables.
- o An internal 3.5-inch FDD supporting two media types:
2HD (double-side, high-density, double-track)
2DD (double-side, double-density, double-track)
The 2HD and 2DD floppy disks can be formatted with 1.44 Mbytes and 720 Kbytes of storage capacity, respectively.
- o A 20-Mbyte 3.5-inch HDD (hard disk drive).
- o An internal 82-key keyboard. For most applications it can be used exactly like a standard typewriter keyboard.
- o An internal 640 x 400 pixel plasma display.
- o A universal auto-sensing power supply that can be used world-wide provides +5 VDC, +12 VDC, -5 VDC and -12 VDC power to all the components in the system unit, including the option cards. For the plasma display, the power supply provides the regulated +205 and +5 VDC power. The power supply's ventilation fans are driven by +12 VDC.
- o A lithium battery that keeps the date and time even when the system unit power is off.
- o A parallel printer (or floppy disk drive), Red/Green/Blue (RGB) direct drive Cathode Ray Tube (CRT) display, and two SERIAL device connectors, located on the system unit's rear panel and right side. The parallel printer connector can be used to connect an external FDD unit by changing the A-B-PRT switch.

1.3 SYSTEM BOARD

Figure 1-3 shows the block diagram of the system board.

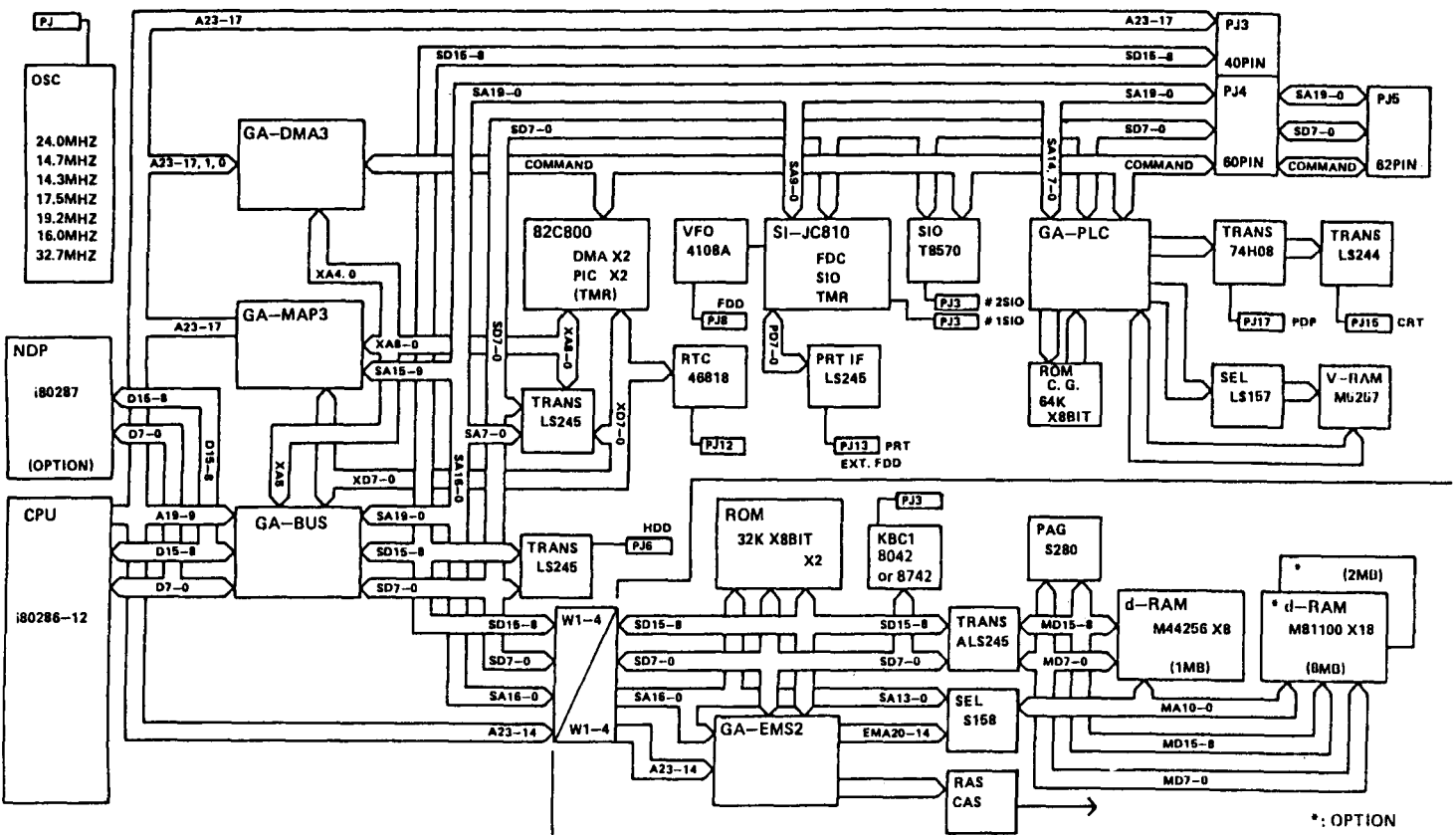

Figure 1-3 Block diagram

System board and memory board are composed of the following components:

System board

- o Central processing unit: CPU (80286-12)
The CPU is a 16-bit microprocessor operated at 12 MHz clock speed.
- o Numeric data processor socket for the 80287-12 (optional).
- o Real time clock: RTC (MC146818)
The RTC continuously keeps the date and time powered by lithium battery.
- o Serial input output: SIO (TC8570)
The SIO controls the RS232C port.
- o Variable frequency oscillator: VFO (MB4108A)
The VFO chip is used for FDD control logic.
- o Two super integration: SI (JC810, M5M82C800)
SI (JC810) includes the FDC (TC8565), SIO (TC8570), and PIT (82C54). SI (M5M82C800) includes the two DMACs (82C37), two PICs (82C59) and one PIT (82C54).
- o Gate arrays:
The following gate arrays are used in the system board. See the T3100e GATE ARRAY SPECIFICATION MANUAL for more information.
 - o DMA controller gate array : DMA3-GA (100 pin)
 - o MAP controller gate array : MAP3-GA (100 pin)
 - o Bus controller gate array : BUS-GA (100 pin)
 - o PLC controller gate array : PLC-GA (100 pin)

Memory board

- o Keyboard controller: KBC (8742 or 8042)
- o Memory
 - Random access memory : RAM 1 Mbyte
 - Read only memory : ROM 64 Kbytes (system BIOS)
- o Gate array
 - The following gate array is used in the memory board.
 - See the T3100e GATE ARRAY SPECIFICATION MANUAL for more information.
 - EMS controller gate array : EMS2-GA (100 pin)

1.4 3.5-INCH FLOPPY DISK DRIVE

The 3.5-inch internal FDD is a high performance, reliable and thin drive that supports 720-Kbyte (formatted) 2DD and 1.44-Mbyte (formatted) 2HD 3.5-inch floppy disks. The FDD is shown in figure 1-5 and its specifications are described in table 1-1.

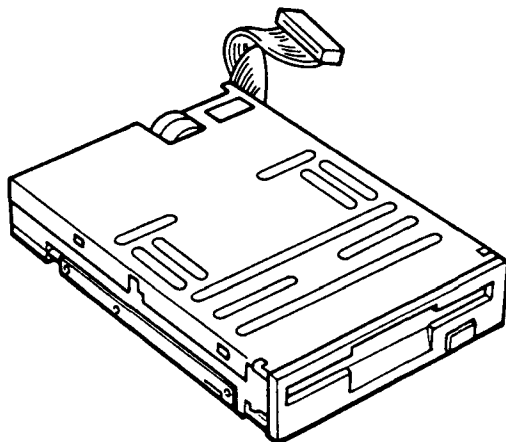

Figure 1-4 3.5-inch FDD

Table 1-1 3.5-inch FDD specifications

Item	Specifications	
	2-Mbyte mode	1-Mbyte mode
Storage Capacity (Kbytes)		
Unformatted	2,000	1,000
Formatted	1,440	720
No. of Heads	2	2
No. of Cylinders	80	80
Access Time (ms)		
1 Track Access	3	3
Average	94	94
Head Settling Time	15	15
Recording Density (bit per inch) (MAX)	17434	8717
Data Transfer Rate (Kbytes per second)	500	250
Rotational Speed (revolutions per minute)	300	300
Recording Method	MFM (Modified Frequency Modulation)	

1.5 3.5-INCH HARD DISK DRIVE

The 20-Mbyte (formatted) HDD is a random access type storage device. It is equipped with non-removable 3.5-inch magnetic disks and mini-winchester type magnetic heads. The HDD has three jumper straps which are located on the hard disk controller (HDC) board.

The HDD is shown in figure 1-5 and its specifications are described in table 1-2. The jumper straps status are shown in table 1-3.

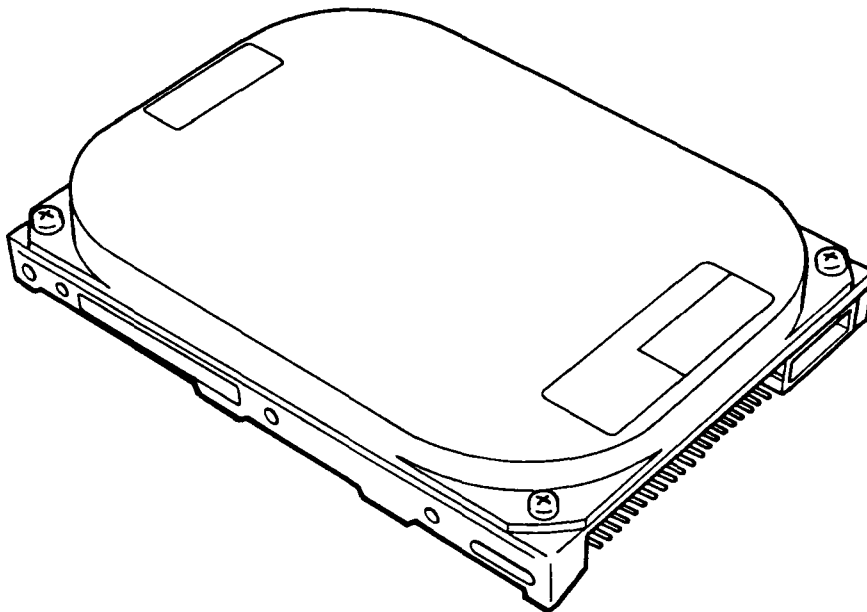

Figure 1-5 3.5-inch HDD

Table 1-2 3.5-inch HDD specifications

Item	Specifications	
	20-Mbyte	40-Mbyte
Storage Capacity : Formatted (Mbytes)	21.4	42.8
Number of Disks	1	1
Data Surfaces	2	2
Data Heads	2	2
Tracks per Surface	636	1,047
Track Density (tpi)	1,150	1,400
Track Capacity : Formatted (bytes)	16,896	20,480
Sectors per Track : (bps)		
Physical Sectors	34	41
User Sectors	33	40
Access Time (ms)		
Track to Track	8	8
Average	27	25
Maximum	50	50
Rotation Speed (rpm)	3,575	3,557
Data Transfer Rate : (bps)		
To/From Media	1.25 M	1.5 M
To/From Buffer	4 M	4.5 M
Start Time (s)		
(0-3575RPM) : Typical	5	5
Maximum	10	10
(0 RPM-READY) : Typical	7	7
Maximum	15	15
Stop Time (s) : Typical	5	5
Maximum	10	10
Interleave	CP3022 3 : 1	1 : 1
	CP3024 1 : 1	
Recording Method	2-7 RLL code (Run Length Limited)	
Recording Density (ID) (bpi)	21,594	30,871

Table 1-3 HDD jumper strap status

20-Mbyte (CP3022)

Signal	Status
E5	Short
E6	Open
E7	Short

20-Mbyte (CP3024) or 40-Mbyte

Signal	Status
$\overline{\text{HSP}}$	Open
$\overline{\text{C/D}}$	Short
$\overline{\text{DHP}}$	Open
$\overline{\text{ACT}}$	Short

1.6 KEYBOARD

The 82-key keyboard is mounted on the system unit. The 82 keys consist of 54 standard keys, 10 function keys, 17 control keys, and **Fn** key.

The keyboard is a key matrix with one of the 82 keys at each vertex.

The keyboard is connected to the keyboard controller on the memory board through a 22-pin flat cable. The keyboard layout is shown in figure 1-6.

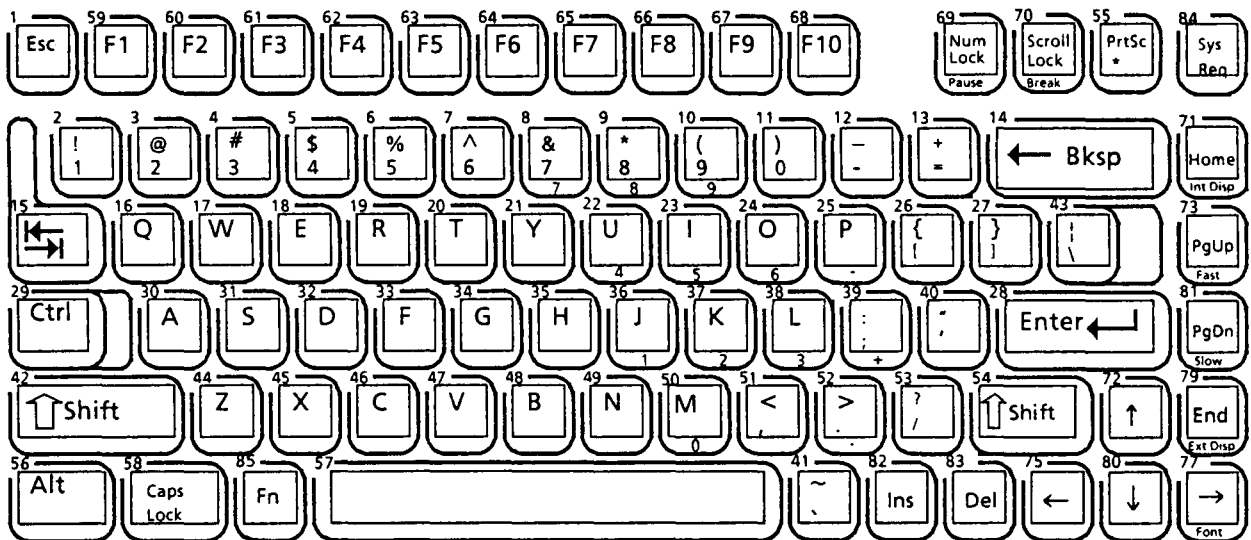

Replace key No. 3, 4, 40, 41

Figure 1-6 Keyboard

1.7 PLASMA DISPLAY

The plasma display is composed of a display panel and driver circuits. It receives vertical and horizontal synchronizing signals, four bit data signals, and shift clock for data transmission. All signals are TTL level compatible. The specifications are described in table 1-4. The plasma display is shown in figure 1-7.

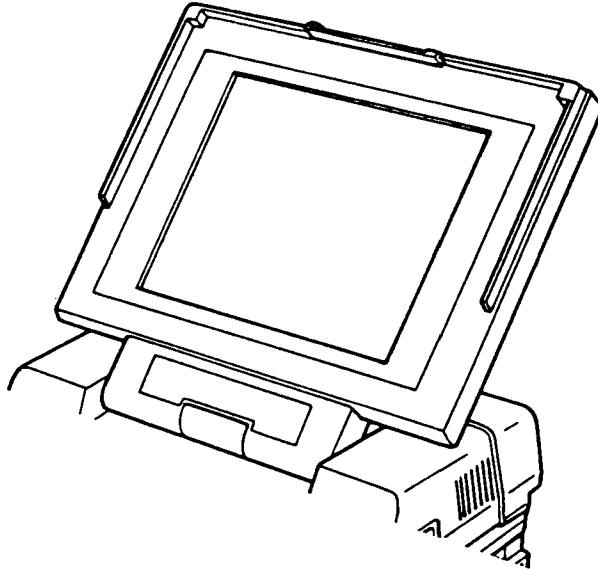

Figure 1-7 Plasma display

Table 1-4 Plasma display specifications

Item	Specifications
No. of Dots (dots)	640 x400
Dot Dimension (mm)	0.16 (W) x 0.24 (H)
Dot Pitch (mm)	0.33 (W) x 0.36 (H)
Display Area (mm)	192 (W) x 144 (H)
Contrast	more than 1:11 (approx. 1:13)
Color	Neon-Orange
Power Requirement	
Anode Logic (E1)	5 +/-0.5 V 10 mA (min.) 400 mA (max.)
Cathode Driver (E2)	205 +/-5 V 3 mA (min.) 160 mA (max.)
Cathode Logic (E3)	5 +/-0.5 V 1 mA (min.) 60 mA (max.)
Power Consumption (watts)	35
Mean Time Between Failure (MTBF) (hours)	30,000

1.8 POWER SUPPLY UNIT

The universal auto-sensing power supply can be used world-wide and supplies +5, -5, +12, -12 and +205 VDC to the system.

The power supply unit is housed in the system unit and it supplies the regulated power to:

- 1) System board
- 2) Memory board
- 3) 3.5-inch floppy disk drive
- 4) 3.5-inch hard disk drive
- 5) Plasma display
- 6) Option boards
- 7) Cooling fans

The above 2) through 4), 6) and one of cooling fans receive the power via the system board.

The power supply unit includes an input line filter, line fuse, cooling fan, power conversion circuitry and connectors.

Input ratings are:

85 to 138 VAC or 170 to 276 VAC, less than 130 W (when input rating is 115 VAC, 60 Hz).

The power supply unit is shown in figure 1-8 and the output ratings are specified in table 1-5.

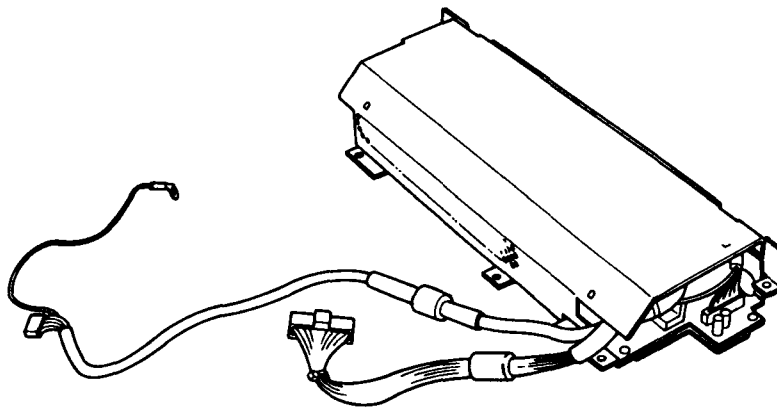

Figure 1-8 Power supply unit

Table 1-5 Power supply unit output rating

Function	DC voltage	Max. current	Requoration tolerance
System Board	+5 V	5.6 A	+/- 5%
System Board & Cooling Fan	+12 V	1.1 A	+/- 5%
System Board	-5 V	300 mA	+/- 5%
System Board	-12 V	300 mA	+/- 5%
Plasma Display	+5 V	60 mA	+/- 10%
Plasma Display	+205 V	105 mA	+/- 5V

File No. : 960-010

2.1 GENERAL

The problem isolation procedures described in part 2 are used to isolate defective FRUs (field replaceable units). The FRUs covered are:

1. Power supply unit
2. System board
3. FDD
4. HDD
5. Keyboard
6. Plasma display

Detailed replacement procedures instructions are described in part 4 and test and diagnostics program operations are described in part 3.

The following items are necessary for implementing the problem isolation procedures.

1. T3100e diagnostics disk
2. Phillips head screwdriver
3. Blade head screwdriver
4. Tweezers
5. 2DD and 2HD formatted work disk (for FDD testing)
6. Cleaning disk kit (for FDD testing)
7. Multimeter
8. Printer port LED

The problem isolation flowchart described in section 2.2 can be used to determine which isolation procedures are necessary to isolate a T3100e problem.

2.2 PROBLEM ISOLATION FLOWCHART

The flowchart in figure 2-1 is used as a guide for determining which FRU is defective. Please confirm the followings before performing the flowchart procedures.

1. No disk is in the FDD.
2. All optional equipments are disconnected.
3. MS-DOS has been installed in drive C before a trouble happens.

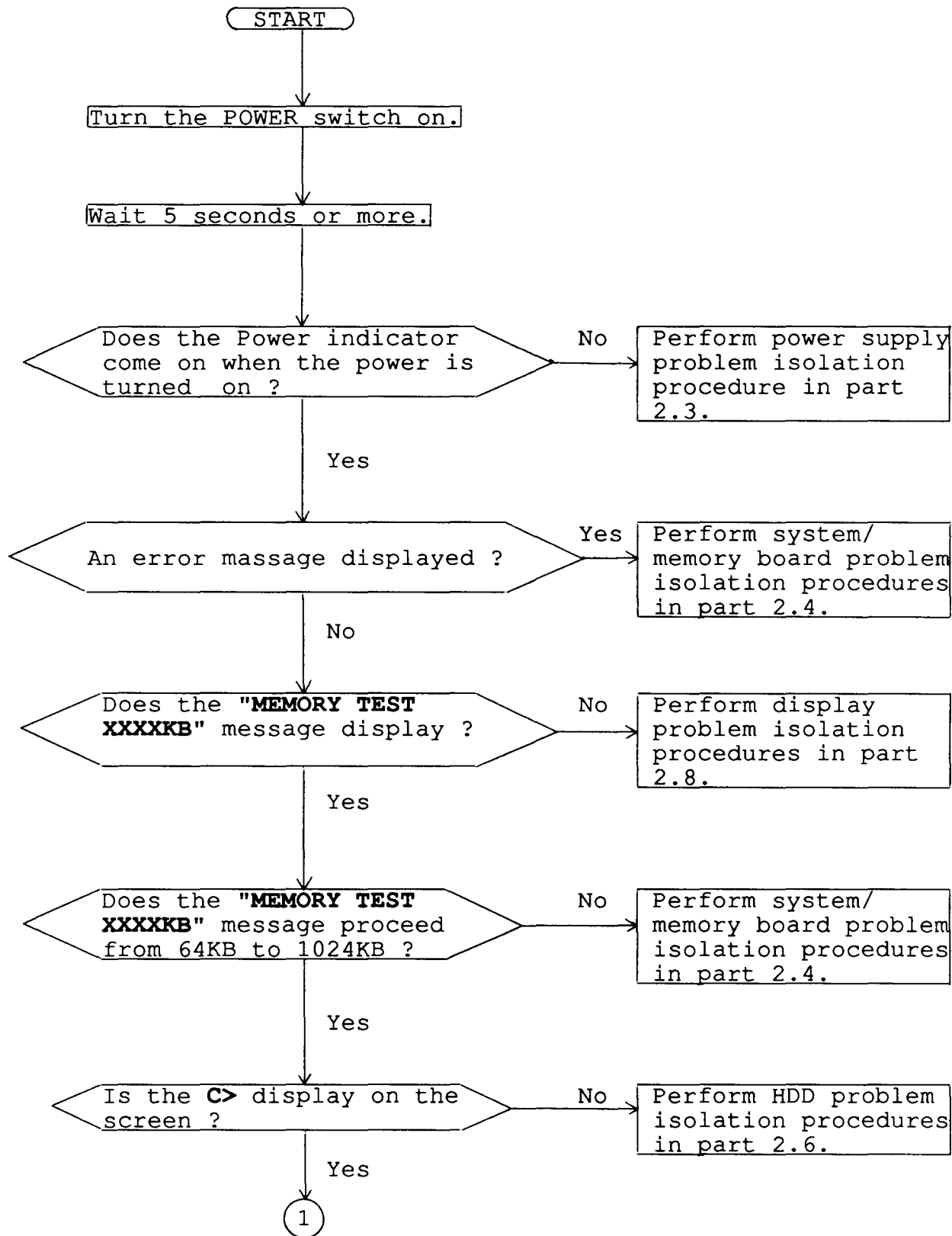

Figure 2-1 Problem Isolation Flowchart

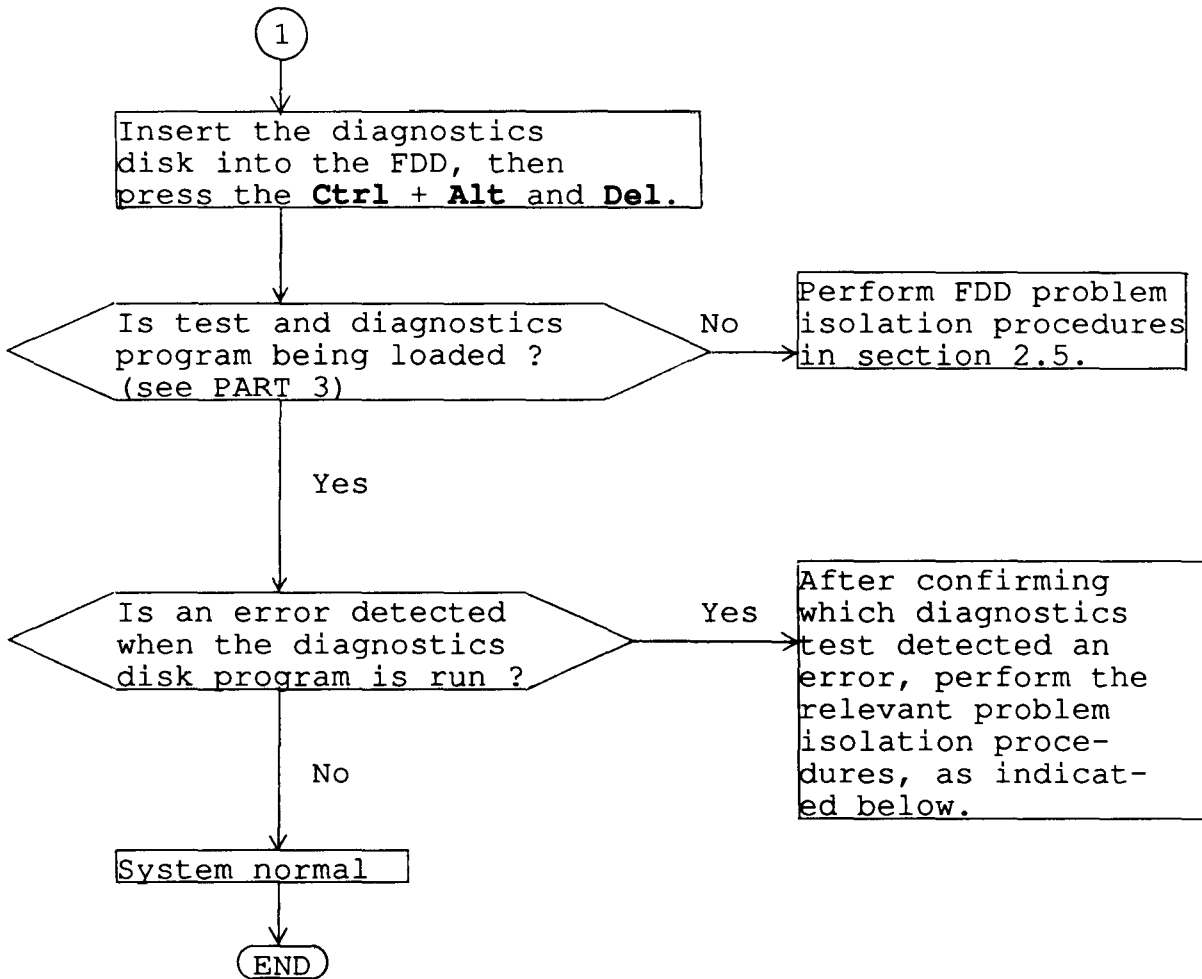

Figure 2-1 Problem isolation flowchart (continued)

1. If an error is detected on the system test, memory test, display test, or real timer test, perform the system board isolation procedures in section 2.4.
2. If an error is detected on the hard disk test, perform the HDD problem isolation procedures in section 2.6.
3. If an error is detected on the keyboard test, perform the keyboard problem isolation procedures in section 2.7.
4. If an error is detected on the floppy disk test, perform the FDD problem isolation procedures in section 2.5.

2.3 POWER SUPPLY UNIT PROBLEM ISOLATION PROCEDURES

WARNING: Dangerous high voltage is supplied to the power supply unit. Pay enough attention on handling. It takes few minutes after power off to discharge the electricity.

This section describes how to determine whether or not the power supply unit is defective. Start with PROCEDURE 1 and continue with other procedures as instructed. The procedures described in this section are:

- PROCEDURE 1: Power Indicator Check
- PROCEDURE 2: Connector Check
- PROCEDURE 3: Output Voltage Check
- PROCEDURE 4: Power Supply Unit Replacement

PROCEDURE 1

Power Indicator Check

1. Turn on the power.
2. If the power indicator lights, go to PROCEDURE 3.
If the indicator does not light, check the AC power cord connection. One end of the AC power cord should be inserted the standard AC wall outlet and the other end should be connected to the AC IN jack on the back of the system unit.
If OK, replace the AC power cord.
After replacing the AC power cord, if the indicator lights, the original cord was probably defective. If the indicator still doesn't light, go to PROCEDURE 2.

PROCEDURE 2

Connector Check

1. Turn off the power, then unplug the AC power cord.
2. Remove the top cover. (Refer to section 4.8.)
3. Remove the power supply unit. (Refer to section 4.9.)
4. If the power supply connector (PJ7) on the system board is connected properly, go to PROCEDURE 3. If it is not connected properly, reconnect it.

PROCEDURE 3Output Voltage Check

1. Plug the AC power cord to the power supply unit, then turn on the power.
2. Use a multimeter to confirm that the output voltages for the two power supply connectors conform to the values given in table 2-1.
3. If the voltages are within the range of values given in table 2-1, the power supply unit is normal, but the system board is probably defective. Go to the system board isolation procedures in section 2.4.
4. If the voltages are still not within the range of values given in table 2-1, go to PROCEDURE 4.

Table 2-1 Power supply unit output voltages

Connector	Pin number		Voltage (Vdc)		
	+lead	-lead	Normal	Min	Max
For system board	1	2,5,6	12	11.4	12.6
	3	2,5,6	-12	-12.6	-11.4
	4	2,5,6	-5	-5.25	-4.75
	8	2,5,6	5	4.75	5.25
For plasma display	1	4	205	200	210
	5	4	5	4.5	5.5
For cooling fan	1	2	12	11.4	12.6

PROCEDURE 4

Power Supply Unit Replacement

1. Turn off the power, then unplug the AC power cord.
2. Replace the power supply unit. (Refer to section 4.9.)
3. If normal operation is restored after replacing the power supply unit, the original power supply unit was probably defective.
4. If normal operation is not restored, another FRU is probably defective. The defective unit must be isolated and replaced.

2.4 SYSTEM BOARD PROBLEM ISOLATION PROCEDURES

CAUTION: Before carrying out any of these procedures, make sure that the FDD is empty. Performing these procedures with a floppy disk in the FDD may result in loss of data.

This section describes how to determine whether or not the system board is defective. Start with PROCEDURE 1 and continue with other procedures as instructed. The procedures described in this section are:

- PROCEDURE 1: Message Check
- PROCEDURE 2: Printer Port LED Check
- PROCEDURE 3: Test Program Execution
- PROCEDURE 4: System Board Replacement

PROCEDURE 1

Message Check

1. Turn on the power.
2. If the system is loaded normally, go to PROCEDURE 3.
3. If the following message is displayed on the screen, press the **F1** key. Execute the setup operation. (See the section 3 for details.)

***** Error in CMOS. Bad battery ***
Check system. Then, press [F1] key**

***** Error in CMOS. Bad check sum ***
Check system. Then, press [F1] key**

***** Error in CMOS. Bad configuration **
Check system. Then, press [F1] key**

***** Error in CMOS. Bad memory size ***
Check system. Then, press [F1] key**

***** Error in CMOS. Bad time function **
Check system. Then, press [F1] key**

4. If the following message is displayed on the screen, turn off the power. Wait 5 seconds or more, then turn on the power. If the following message is displayed again, go to HDD isolation procedures in section 2.6.

**Insert system disk in drive
Press any key when ready**

5. If the following message is displayed on the screen, the system may not be set up correctly. Go to the system setup menu and select the appropriate system configuration. (see the part 3 for details.) If the following message is displayed again, go to PROCEDURE 5.

Video RAM error

CRTC error

6. If the following message is displayed on the screen, go to PROCEDURE 4.

CPU flag register error
KBC IBF/OBF error
KBC IBF error
KBC self test error
KBC OBF error
CPU register error
ROM checksum error
PIT channel 2 error
CMOS shutdown byte error
DMA channel 0 error
DMA channel 1 error
DMA page register error
Memory refresh error
1st 64KB memory error
Error interrupt controller 1
Error interrupt controller 2
VRAM error
Memory verify error at X:X found X expanded X
Memory parity error at X:X found X expected X
Error interrupt and stuck NMI
Error interrupts and stuck NMI
Error interrupts and stuck NMI
Error protect mode...
Error sizing expansion memory
Memory verify error at X:X:X found X expected X
Memory verify error at X:X:X found X expected X
Error processor exceptional interrupts...
Refresh timing error
Error encountered initializing hard drive
First 64KB memory error
LIM page register error

7. If none of the above messages are displayed and you have a printer port LED, go to PROCEDURE 2.

PROCEDURE 2

Printer Port LED Check

1. Turn off the power.
2. Plug the printer port LED into the PRT/FDD connector on the back of the unit and set the A-B-PRT switch to PRT position.
3. While watching the printer port LED, turn on the power. The printer port LED will light when the power switch is turned on.
4. Read the final LED status from left to right as a hexadecimal value.
5. If the final LED status matches any of the error code values in the table 2-3, go to PROCEDURE 4.
6. If the final LED status is **33H**, go to PROCEDURE 3.

Table 2-2 Printer port LED normal status

Status	Error message
00H	Shutdown process and video initialization
01H	CPU test 1
02H	KBC test 1
03H	KBC test 2
04H	KBC test 3
05H	KBC test 4
06H	LSI initialization
07H	CPU test 2
08H	RTC initialization
09H	ROM checksum test
0AH	Video initializatiion
0BH	Reserved
0CH	Reserved
0DH	PIT Channel 2 test and initialization
0EH	Reserved
0FH	CMOS RAM test
10H	DMA Channel 0 test

Table 2-2 Printer port LED normal status (continued)

Status	Message
11H	DMA channel 1 test
12H	DMA page register test
13H	Memory refresh test
14H	First 64KB memory test
15H	Interrupt vector set
16H	PIC 1 mask register test
17H	PIC 2 mask register test
18H	CMOS Battery test
19H	CMOS chechsum test
1AH	Reserved
1BH	Keyboard initialization 1
1CH	VRAM test
1DH	Video I/O initialization
1EH	System memory size set
1FH	System memory size check
20H	System memory and extra memory test
21H	PIC test
22H	NMI and parity test
23H	Interrupt process test
24H	Protect mode test
25H	Extended memory size check
26H	Extended memory test
27H	Protect mode exception processing test
28H	Reserved
29H	CRT type check
2AH	PIT interrupt check
2BH	Hardware interrupt vector set
2CH	Keyboard initialization 2
2DH	FDD intialization
2EH	SIO/Printer initialization
2FH	HDD initialization
30H	Option ROM check
31H	Timer check
32H	NDP initialization
33H	Prepare for boot

Table 2-3 Printer port LED error status

Status	Error message	Process
81H	CPU flag register error	halt
82H	KBC IBF/OBF error	halt
83H	KBC IBF error	halt
84H	KBC self test error	halt
85H	KBC OBF error	halt
87H	CPU register error	halt
89H	ROM checksum error	halt
8DH	PIT channel 2 error	halt
8FH	CMOS shutdown byte error	halt
90H	DMA channel 0 error	halt
91H	DMA channel 1 error	halt
92H	DMA page register error	halt
93H	Memory refresh error	halt
94H	1st 64KB memory error	halt
96H	Error interrupt controller 1	halt
97H	Error interrupt controller 2	Continue
9CH	VRAM error	halt
A0H	Memory verify error at X:X found X expanded X	Continue
A1H	Error interrupt and stuck NMI	Continue
A2H	Error interrupts and stuck NMI	Continue
A3H	Error interrupts and stuck NMI	Continue
A4H	Error protect mode...	Continue
A5H	Error sizing expansion memory	Continue
A6H	Memory verify error at X:X:X found X expected X	Continue
	Memory verify error at X:X:X found X expected	
A7H	Error processor exceptional interrupts...	Continue
AAH	Refresh timing error	Continue
AFH	Error encountered initializing hard drive	Continue
D4H	First 64KB memory error	halt
EOH	LIM page register error	Continue

PROCEDURE 3

Test Program Execution

1. Execute the following tests on the Diagnostic Test Menu. (Refer to Part 3 Test and Diagnostics.)
 1. System test
 2. Memory test
 3. Keyboard test
 4. Display test
 5. Floppy disk test
 6. Printer test
 7. ASYNC test
 8. Hard disk test
 9. Real timer test
2. If an error is detected during the system test, memory test, Printer test, ASYNC test, or real timer test, go to PROCEDURE 4.
3. If an error is detected during the floppy disk test, go to FDD problem isolation procedures in section 2.5.
4. If an error is detected during the hard disk test, go to HDD problem isolation procedures in section 2.6.
5. If an error is detected during the keyboard test, go to keyboard problem isolation procedures in section 2.7.
6. If an error is detected during the display test, go to display problem isolation procedures in section 2.8.

PROCEDURE 4

System Board Replacement

1. Replace the system board. (Refer to section 4.16.)
2. If normal operation is restored after replacing the system board, the original system board is probably defective.
3. If normal operation is not restored, another FRU is probably defective. The defective unit must be isolated by the test and diagnostics program and replaced.

2.5 FLOPPY DISK DRIVE PROBLEM ISOLATION PROCEDURES

This section describes how to determine whether or not the floppy disk drive is defective. Start with PROCEDURE 1 and continue with other procedures as instructed. The procedures described in this section are:

- PROCEDURE 1: Test and Diagnostics Program
Loading Check
- PROCEDURE 2: Message Check
- PROCEDURE 3: Head Cleaning
- PROCEDURE 4: FDD Test Execution
- PROCEDURE 5: FDD Connector Check
- PROCEDURE 6: New FDD Connection

PROCEDURE 1

Test and Diagnostics Program Loading Check

1. Turn off the power.
2. Insert the diagnostics disk into the FDD.
3. Turn on the power.
4. If loading starts normally, go to PROCEDURE 3. (See section 3.2 to determine if loading has started normally.)
5. If loading has not started normally, go to PROCEDURE 2.

PROCEDURE 2Message Check

1. When the power switch is turned on after the diagnostics disk is inserted into the FDD, message (a), (b), or (c) shown below may appear.
 - (a) ***** FDD A is not installed *****
 - (b) **Non-System disk or disk error**
Replace and press any key when ready
 - (c) **** FDD load error or Bad system disk ****
Insert system disk in drive
Press any key when ready
2. If message (a) is displayed, check that the A-B-PRT switch is set to PRT. If it is not set to PRT, set it to PRT. If it is set to PRT, go to PROCEDURE 5.
3. If message (b) or (c) is displayed, the contents of the floppy disk is damaged, or a disk other than the diagnostics disk has been inserted into the FDD. Insert a new diagnostics disk into the FDD. If loading completes, go to PROCEDURE 4. If loading does not complete, go to PROCEDURE 3.
4. If none of the above messages appears, go to PROCEDURE 5.

PROCEDURE 3

Head Cleaning

1. Turn off the power.
2. Insert the cleaning disk into the FDD.
3. Turn on the power.
4. If normal operation is restored after cleaning the head, go to PROCEDURE 4.
5. If normal operation is not restored, go to PROCEDURE 5.

PROCEDURE 4FDD Test Execution

1. Run the floppy disk test as indicated on the diagnostic test menu.
2. If an error is generated during the floppy disk test, an error code and status will be displayed. The error codes are described in table 2-4. Go to PROCEDURE 6.
3. If no error is generated, the FDD is normal.

Table 2-4 FDD error code

Code	Status
01	Bad Command
02	Address Mark Not Found
03	Write Protected
04	Record Not Found
06	Media Removed
08	DMA Overrun Error
09	DMA Boundary Error
10	CRC Error
20	FDC Error
40	Seek Error
60	FDD Not Drive
80	Time Out Error
EE	Write Buffer Error

PROCEDURE 5

FDD Connector Check

1. Turn off the power, then unplug the AC power cord.
2. Remove the top cover. (Refer to section 4.8.)
3. Check that the FDD connection (PJ8) is secure.
4. If the FDD cable is securely connected to the system board, go to PROCEDURE 6.
5. If the FDD cable is not securely connected to the system board, secure the connection.

PROCEDURE 6

New FDD Connection

1. Turn off the power.
2. Remove the FDD. (Refer to section 4.12.)
3. Connect a new FDD to the FDD connector without installing the new FDD. Then connect all of the FRUs removed during FDD removal to their corresponding connectors without installing the FRUs.
4. Turn on the power.
5. If normal operation is restored, the original FDD is probably defective. Reassemble the system.
6. If normal operation is not restored, the system board is probably defective. Refer to section 2.4.

2.6 HARD DISK DRIVE PROBLEM ISOLATION PROCEDURES

This section describes how to determine whether or not the hard disk drive is defective. Start with PROCEDURE 1 and continue with other procedures as instructed. The procedures described in this section are:

- PROCEDURE 1: HDD Indicator Check
- PROCEDURE 2: Message Check
- PROCEDURE 3: Format Execution
- PROCEDURE 4: Hard Disk Test Execution
- PROCEDURE 5: Connector Check
- PROCEDURE 6: HDD Jumper Straps Check
- PROCEDURE 7: New HDD Connection

PROCEDURE 1

HDD Indicator Check

1. Turn off the power.
2. If there is a floppy disk in the FDD, take it out.
3. Wait 5 seconds or more after turning off the power, then turn on the power.
4. If the HDD indicator blinks briefly, then goes out, go to PROCEDURE 2. If the HDD indicator continues blinking, go to PROCEDURE 4.
5. If the HDD indicator does not light at all, go to PROCEDURE 5.

PROCEDURE 2

Message Check

1. If the operating system is loaded normally, go to PROCEDURE 4.
2. If one of the following message is displayed on the screen, go to PROCEDURE 3.

**** HDD Load error or Bad system disk ****
Insert system disk in drive.
Press any key when ready

Check system disk in drive
Press any key when ready

PROCEDURE 3

Format Execution

CAUTION: The contents of the hard disk will be erased when the FORMAT command is run. Before running this test, transfer the contents of the hard disk to floppy disks. This can be done with the MS-DOS BACKUP command. (See the MS-DOS Manual for details.)

1. Remove the diagnostics disk from the FDD, then insert the MS-DOS system disk in.
2. Make partition of the hard disk by entering the FDISK command. (See the MS-DOS Manual for details.)
3. Format the hard disk by entering the FORMAT command. (See the MS-DOS Manual for details.) At this time use /S switch to transfer the system program.
4. If normal operation is restored, the HDD is normal.
5. If normal operation is not restored, go to PROCEDURE 5.

PROCEDURE 4Hard Disk Test Execution

CAUTION: The contents of the hard disk will be erased when the test program is run. Before running this test, transfer the contents of the hard disk to floppy disks. This can be done with the MS-DOS BACKUP command. (See the MS-DOS Manual for details.)

1. Insert the diagnostics disk into the FDD and load the test and diagnostics programs.
2. Run the hard disk test as indicated on the diagnostic test menu.
3. If an error is detected during the hard disk test, an error code and status will be displayed; go to PROCEDURE 6. The error codes are described in table 2-5.
4. If no error is generated, the HDD is normal. Enter the MS-DOS FDISK command to make partition of the hard disk. Then enter the MS-DOS FORMAT command. (See the MS-DOS Manual for details.)

Table 2-5 HDD error code

Code	Status
01	Bad command error
02	Bad address mark
04	Record not found
05	HDC not reset
07	Drive not initialize
09	DMA boundary error
0A	Bad sector error
0B	Bad track error
10	ECC error
11	ECC recover enable
20	HDC error
40	Seek error
80	Time out error
AA	Drive not ready
BB	Undefined
CC	Write fault
E0	Status error
F0	Not sense error (HW.code=FF)

PROCEDURE 5

Connector Check

1. Turn off the power, then unplug the AC power cord.
2. Remove the top cover. (Refer to section 4.8)
3. Check that the HDC signal cable (PJ6) and HDD power cable (PJ11) are secure.
4. If both cables are securely connected to the system board, go to PROCEDURE 6.
5. If the cables are not securely connected, secure them.

PROCEDURE 6

HDD Jumper Straps Check

1. Remove the disk support (Refer to section 4.12.).
2. Check that the jumper straps are set correctly as shown in figure 2-2 and described in table 2-6.
3. If the jumper straps are set correctly, go to PROCEDURE 7.
4. If the jumper straps are not set correctly, set them correctly.

Table 2-6 HDD jumper straps functions

20-Mbyte (CP3022)

Signal	Status
E5	Short
E6	Open
E7	Short

20-Mbyte (CP3024) or 40-Mbyte

Signal	Status
$\overline{\text{HSP}}$	Open
$\overline{\text{C/D}}$	Short
$\overline{\text{DHP}}$	Open
$\overline{\text{ACT}}$	Short

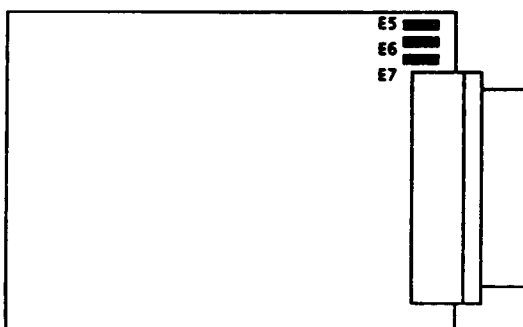

20-Mbyte (CP3022)

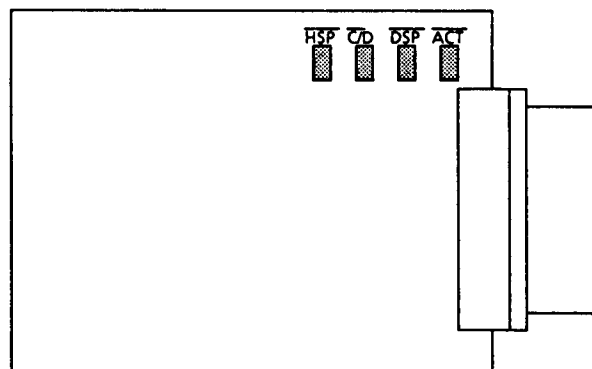

20-Mbyte (CP3024) or 40-Mbyte

Figure 2-2 HDD jumper straps

PROCEDURE 7

New HDD Connection

1. Turn off the power.
2. Remove the HDD. (Refer to section 4.13.)
3. Connect a new HDD to the system board without installing the HDD. Then connect all the FRUs removed during HDD removal without installing the FRUs.
4. If normal operation is restored, the original HDD is probably defective. Reassemble the system.
5. If normal operation is not restored, the system board is probably defective. Refer to section 2.4.

2.7 KEYBOARD PROBLEM ISOLATION PROCEDURES

This section describes how to determine whether or not the keyboard is defective. Start with PROCEDURE 1 and continue with other procedures as instructed. The procedures described in this section are:

- PROCEDURE 1: Input Check
- PROCEDURE 2: Keyboard Test Execution
- PROCEDURE 3: Connector Check
- PROCEDURE 4: New Keyboard Connection

PROCEDURE 1

Input Check

1. Insert an MS-DOS system disk into the FDD.
2. Turn on the power.
3. When the prompt appears on the screen, press any of the white keys on the keyboard (any character or the space bar).

<p>CAUTION: Do not type an MS-DOS acceptable command such as del and format. Such operation may erase your important program or data.</p>
--

If the character you press appears on the screen, press Enter. Go to PROCEDURE 2.

4. If the character does not appear on the screen, go to PROCEDURE 3.

Toshiba Personal Computer MS-DOS Version X.XX / (RXXXXX)

(C) Copyright Toshiba Corporation 1983,1986
(C) Copyright Microsoft Corporation 1981,1986

Current date is XXX X_XX_19XX
Enter new date (mm-dd-yy) : _
Current time is X:XX:XX,XX
Enter new time : _

COMMAND Version X.XX
A> abcdefghijklmnopqrst.....

PROCEDURE 2

Keyboard Test Execution

1. Insert the diagnostics disk into the FDD and load the test and diagnostics program. (Refer to section 3.)
2. Run the keyboard test as indicated on the diagnostic test menu.
3. If an error is detected during the test, go to PROCEDURE 3.
4. If no error is detected during the test, the keyboard is normal.

PROCEDURE 3

Connector Check

1. Turn off the power, then disconnect the AC power cord.
2. Lift up the top cover. (Refer to section 4.8.)
3. Lift up the keyboard and check that the keyboard cable (PJ3) is securely connected to the system board. If it is securely connected, go to PROCEDURE 4.
4. If it is not securely connected, secure it.

PROCEDURE 4

New Keyboard Connection

1. Turn off the power, then unplug the AC power cord.
2. Remove the keyboard. (Refer to section 4.2.)
3. Connect a new keyboard to the system board without installing it.
4. If normal operation is restored after connecting the new keyboard, the original keyboard is probably defective. Install the new keyboard.
5. If normal operation is not restored, the system board is probably defective. Refer to section 2.4.

2.8 PLASMA DISPLAY PROBLEM ISOLATION PROCEDURES

This section describes how to determine whether or not the PLASMA DISPLAY is defective. Start with PROCEDURE 1 and continue with other procedures as instructed. The procedures described in this section are:

- PROCEDURE 1: Display Check
- PROCEDURE 2: Display Test Execution
- PROCEDURE 3: PDP Connector Check
- PROCEDURE 4: New PDP Connection

PROCEDURE 1

Display Check

1. Turn off the power.
2. Wait 5 seconds or more and turn on the power. After turning on the power, the following message should be displayed on the upper left-hand corner of the screen:

MEMORY TEST XXXXKB

3. If the above message appears, go to PROCEDURE 2.
4. If the above message does not appear:
 - (a) Check that CRT indicator is light. If CRT indicator is light, hold the **Fn** key, then press the **Home** key.

After performing (a), reperform steps 1 and 2. If the message in step 2 still fails to appear, go to PROCEDURE 3.

PROCEDURE 2

Display Test Execution

1. Insert the diagnostics disk into the FDD and run the display test as indicated on the diagnostic test menu.
2. If an error is detected during the display test, the system board is probably defective. Refer to section 2.4.
3. If no error is generated, the plasma display is normal.

PROCEDURE 3

PDP Connector Check

WARNING: Dangerous high voltage is supplied to the plasma display panel. Pay enough attention on handling.

1. Turn off the power, then unplug the AC power cord.
2. Remove the PDP without disconnecting the cables (Refer to section 4.5.) and check that the cables are securely connected to the plasma display board (Refer to figure 2-3.)
3. If the cable is securely connected, go to PROCEDURE 4.
4. If the cable is not securely connected, secure it.

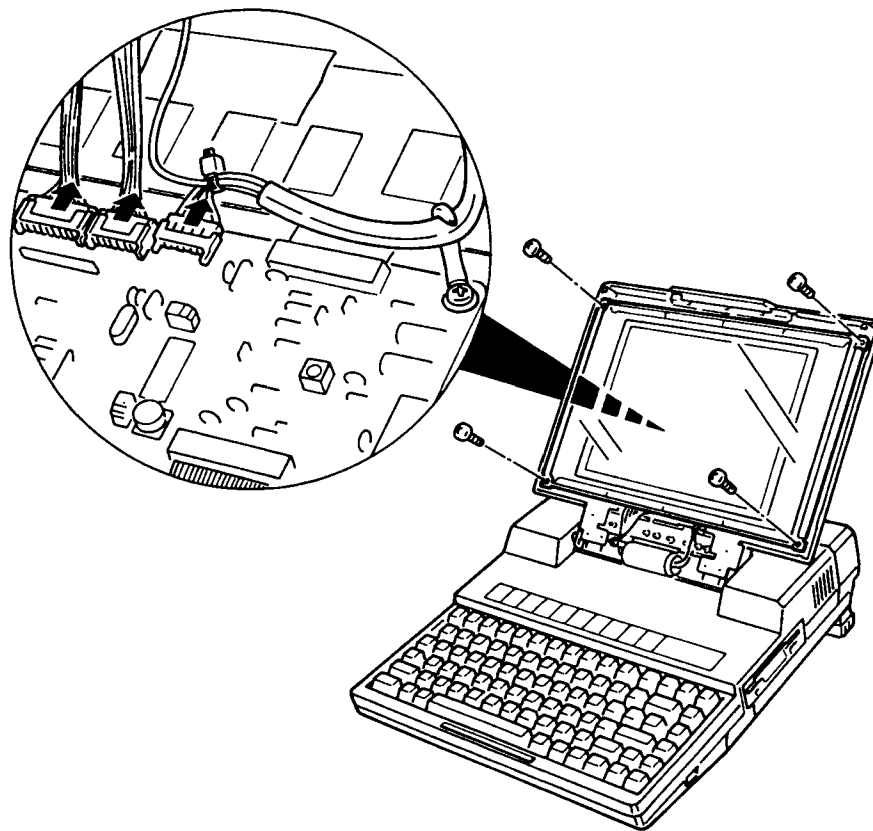

Figure 2-3 PDP connector check

PROCEDURE 4

New PDP Connection

1. Connect a new PDP without installing it.
2. If normal operation is restored after connecting the new PDP, the original PDP is probably defective. Reassemble the system.
3. If normal operation is not restored, the system board is probably defective. Refer to section 2.4.

File No. : 960-010

3.1 GENERAL

This part explains test and diagnostics programs. That checks the functions of all hardware modules of the T3100e.

There are 21 programs grouped into two modules: the service program module (DIAGNOSTICS MENU) and test program module (DIAGNOSTIC TEST MENU).

The service program module is composed of 10 tasks:

1. DIAGNOSTIC TEST
2. HARD DISK FORMAT
3. SEEK TO LANDING ZONE (HDD)
4. HEAD CLEANING
5. LOG UTILITIES
6. RUNNING TEST
7. FDD UTILITIES
8. SYSTEM CONFIGURATION
9. EXIT TO MS-DOS
10. SETUP

The test program module is composed of 11 tests:

1. SYSTEM TEST
2. MEMORY TEST
3. KEYBOARD TEST
4. DISPLAY TEST
5. FLOPPY DISK TEST
6. PRINTER TEST
7. ASYNC TEST
8. HARD DISK TEST
9. REAL TIMER TEST
10. NDP TEST
11. EXPANSION TEST

The following items are necessary for carrying out the test and diagnostic programs.

1. T3100e diagnostics disk
2. MS-DOS system disk
3. 2DD and 2HD formatted work disks (For FDD test)
4. Cleaning disk kit (For read cleaning)
5. Printer wraparound connector
(For printer wraparound test)
6. RS-232-C wraparound connector
(For ASYNC wraparound test)

Service personnel can use these programs to isolate problems by selecting the appropriate program and operation procedures described in section 3.2.

3.2 OPERATIONS

1. Insert the diagnostics disk in the floppy disk drive, and turn on the power to boot the T3100e.
2. The following message will appear:

**TOSHIBA personal computer T3100e DIAGNOSTICS
version X.XX (C) copyright TOSHIBA Corp. 1988**

DIAGNOSTICS MENU :

- 1 - DIAGNOSTIC TEST
- 2 - HARD DISK FORMAT
- 3 - SEEK TO LANDING ZONE (HDD)
- 4 - HEAD CLEANING
- 5 - LOG UTILITIES
- 6 - RUNNING TEST
- 7 - FDD UTILITIES
- 8 - SYSTEM CONFIGURATION
- 9 - EXIT TO MS-DOS
- 0 - SETUP

PRESS [0] - [9] KEY

Detailed explanations of the service programs and the operations are given in section 3.17 to 3.24.

<p>NOTE: To stop the test program: (1) During keyboard operation, press Ctrl + C (2) While running the test program, press Ctrl + Break</p>
--

3. Type in **1**, then press **Enter** and the following message will appear:

**TOSHIBA personal computer T3100e DIAGNOSTICS
version X.XX (C) copyright TOSHIBA Corp. 1988**

DIAGNOSTIC TEST MENU :

- 1 - SYSTEM TEST**
- 2 - MEMORY TEST**
- 3 - KEYBOARD TEST**
- 4 - DISPLAY TEST**
- 5 - FLOPPY DISK TEST**
- 6 - PRINTER TEST**
- 7 - ASYNC TEST**
- 8 - HARD DISK TEST**
- 9 - REAL TIMER TEST**
- 10 - NDP TEST**
- 11 - EXPANSION TEST**
- 88 - FDD & HDD ERROR RETRY COUNT SET**
- 99 - EXIT TO DIAGNOSTICS MENU**

PRESS [1] - [9] KEY

Numbers, 1 to 11 are diagnostic tests.
Number 88 is for setting the floppy disk drive and hard disk drive error retry count.
Number 99 is for returning to the DIAGNOSTICS MENU.
When selecting the floppy disk test or hard disk test, special sub-messages will appear, as described in sections 3.8 and 3.11.

4. After typing in a test number (1 to 11) of the DIAGNOSTIC TEST MENU, pressing **Enter** displays as follows:

```
TEST NAME                                XXXXXXXX
SUB TEST      : XX                      ERROR COUNT : XXXXX
PASS COUNT    : XXXXX                   READ DATA  : XX
WRITE DATA   : XX                      STATUS      : XXX
ADDRESS       : XXXXXX
SUB-TEST MENU :
01 - ROM CHECKSUM
02 - HW status
99 - Exit to DIAGNOSTIC TEST MENU
```

SELECT SUB-TEST NUMBER ? _

The screen shown above, for example, appears when you type **1** and **Enter**.

5. Select a subtest. Type in the subtest number, then press **Enter**. The following message will appear:

TEST LOOP (1:YES/2:NO) ?

NOTE: If you select KEYBOARD TEST, this message will not appear.

If you select YES (by typing in **1**, then pressing **Enter**):
Each time a test cycle ends, it increments the pass counter by one and repeats the test cycle.
If you select NO (by typing in **2**, then pressing **Enter**):
At the end of a test cycle, the test execution is terminated and you exit to the subtest menu.

6. Type in **1** or **2**, then press **Enter**. The following message will appear:

ERROR STOP (1:YES/2:NO) ?

If you select YES (by typing in **1**, then pressing **Enter**):
When an error occurs, the error status is displayed and execution of the test program stops and the operation guide is displayed on the right side of the display screen.
If you select NO (by typing in **2**, then pressing **Enter**):
When an error occurs, the error status is displayed then the error counter is incremented by one and you can continue the test.

7. Type in **1** or **2**, then press **Enter** and the test program will run. Each subtest is described in section 3.3.
8. When an error occurs during the test program, the following message will appear: (if you answer YES for ERROR STOP question,)

ERROR STATUS NAME **[[HALT OPERATION]]**
 1: Test End
 2: Continue
 3: Retry

- 1: Terminates the test program execution and exits to the subtest menu.
- 2: Continues the test.
- 3: Retires the test.

The error code and error status names are described in section 3.15.

3.3 SUBTEST NAMES

Table 3-1 lists the subtest of each test program.

Table 3-1 Subtest names and execution time

No.	Test name	Subtest No.	Subtest item	Time [s]
1	SYSTEM	01	ROM checksum	
		02	HW status	
2	MEMORY	01	RAM constant data	20
		02	RAM address pattern data	5
		03	RAM refresh	12
		04	Protected mode	50 *
		05	Extended memory	50 *
		06	LIM/EMS mode (Expanded memory)	22 *
3	KEYBOARD	01	Pressed key display	
		02	Pressed key code display	
4	DISPLAY	01	VRAM read/write	1
		02	Character attributes	
		03	Character set	
		04	80*25 Character display	
		05	Graphics display (color set 0/1)	
		06	640*200 Graphics display (mode 6)	
		07	640*400 Graphics display (mode 74)	
		08	Display page	14
		09	"H" pattern display	
		10	LED & Font change	
5	FDD	01	Sequential read	50 65
		02	Sequential read/write	80 130
		03	Random address/data	10 10
		04	Write specified address	2DD 2HD
		05	Read specified address	

*: This execution time assumes that 2 Mbytes of expansion memory is installed. Execution time will vary with amount of memory installed.

Table 3-1 Subtest names and execution time (continued)

No.	Test name	Subtest No.	Subtest item	Time [s]
6	PRINTER	01	Ripple pattern	110
		02	Function	15
		03	Wrap around	1
7	ASYNC	01	Wrap around (board)	1
		02	Board (#1) < = > board (#2)	
		03	Point to point (send)	1
		04	Point to point (receive)	1
		05	Card modem loopback	5
		06	Card modem on-line test	10
		07	Dial tester test	60
		08	Interrupt test (IRQ4, 3, 5)	2
8	HDD	01	Sequential read	225
		02	Address uniqueness	
			1. Forward sequential	230
			2. Reverse	270
			3. Random	130
		03	Random address/data	14
		04	Cross talk & peak shift	225
		05	Write/read/compare (CE)	
		06	Write specified address	
		07	Read specified address	
08	ECC circuit (CE cylinder)	5		
09	Sequential write	115		
10		10	W-R-C specified address	
9	REAL TIMER	01	Real time test	
		02	Backup memory test	1
		03	Real time carry test	
10	NDP	01	NDP test	
11	EXPANSION UNIT	01	Box wrap around test	3
		02	Box mono video ram test	1
		03	Wrap around test (16bit bus)	

3.4 SYSTEM TEST

Subtest 01 ROM checksum

This test performs the ROM checksum test on the system board.

(Test extent : F0000H - FFFFFH 64KB)

Subtest 02 H/W status

This test reads the system hardware status, then displays the status as shown below. Press **Enter** to return to the system test's SUB-TEST MENU. Table 3-2 describes the hardware status bits. If you want to return to the SYSTEM TEST menu, press **Enter**.

76543210
H/W status = 10101100

Bit7 --- Display mode = Plasma
Bit6 --- CPU clock = 12MHZ
Bit5 ---
Bit4 --- 2MB FDD = 2MB
Bit3 --- Internal FDDs = 1
Bit2 --- Drive A/B = Normal
Bit1 --- External FDD = OFF
Bit0 --- Internal FDD = 2HD type

Table 3-2 Hardware status bit

Items	H/W status	1	0
Bit7	Display mode	Plasma	CRT
Bit6	CPU clock	6MHz	12MHz
Bit5	Reserved		
Bit4	2MD FDD	1.6MB	2MB
Bit3	Internal FDDs	1	2
Bit2	Drive A/B	Normal	Change
Bit1	External FDD	ON	OFF
Bit0	Internal FDD	2DD type	2HD type

3.5 MEMORY TEST

Subtest 01 RAM constant data (in real mode)

This subtest writes constant data to memory, then reads and compares it with the original data. The constant data is FFFFH, AAAAH, 5555H, 0101H, and 0000H.

Subtest 02 RAM address pattern data (in real mode)

This subtest creates an address pattern by XORing (Exclusive-ORing) the address segment and address offset, writes the address pattern into the segment address and the offset address, then reads and compares it with the original data.

Subtest 03 RAM refresh (in real mode)

This subtest writes 256 bytes of constant data to memory, then reads and compares it with the original data. The constant data is "AAAAH" and "5555H". There is a delay between the write and the read operations.

Subtest 04 Protected mode

This subtest writes fixed data and address data to memory (addresses 100000H to the max.) in protected mode, then reads and compares it with the original data.

Subtest 05 Extended memory

For the memory located at the address 100000H or more, the test program writes data, reads it back, and compares in the microprocessor's protected mode. The data patterns used by the program are one address pattern and four constant (i.e. fixed) data patterns. Address pattern data is a data generated by some logical operation with its memory address information. Four constant data patterns are FFFFH, AAAAH, 5555H, and 0000H.

Subtest 06 LIM/EMS (Expanded memory)

Registers controlling the Lotus Intel Microsoft / expanded memory specification (LIM/EMS) are checked. Page information is written at the beginning of each page to verify its paging function. Then, the memory assigned as LIM/EMS is checked by a write/read/compare algorithm using a LIM/EMS window.

3.6 KEYBOARD TEST

Subtest 01 Pressed key display

NOTE: The **Fn** key is not subjected to the test.

When the keyboard layout (as shown below) is drawn on the display, press any key and check that the corresponding key on the screen is changed to the character "*".

When a key is held depressed, the display will blink designating the auto-repeat function.

KEYBOARD TEST **IN PROGRESS 30100**

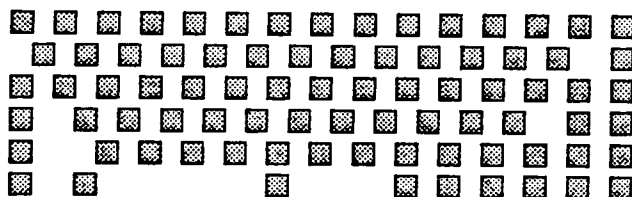

IF TEST OK, PRESS [DEL] THEN [ENTER] KEY

Subtest 02 Pressed key code display

When a key is pressed, its scan code, character code, and key top name are displayed on the screen in the format shown below.

The **Ins**, **Caps lock**, **Num lock**, **Scroll lock**, **Alt**, **Ctrl**, **Left Shift**, and **Right Shift** keys are displayed in reverse screen when pressed.

The scan codes, character codes and key top names are shown in APPENDIX E.

KEYBOARD TEST IN PROGRESS 30200

Scan code = XX
Character code = XX
Keytop = XXXX

Ins Lock	Caps Lock	Num Lock	Scroll Lock
Alt	Ctrl	Left Shift	Right Shift

PRESS [Enter] KEY

3.7 DISPLAY TEST

Subtest 01 VRAM read/write

This subtest writes constant data (FFFFH, AAAAH, 5555H, 0000H) and address data to video RAM (256 Kbytes), then reads the data written and compares it with the original data.

Subtest 02 Character attributes

This subtest checks:

Normal Display
Intensified Display
Reverse Display
Blinking Display

For color displays, all seven colors used (blue, red, magenta, green, cyan, yellow, white) are displayed. The background and foreground colors can then be checked for brightness. The display below appears on the screen when this test is run.

CHARACTER ATTRIBUTES

**NEXT LINE SHOWS NORMAL DISPLAY.
NNNNNNNNNNNNNNNNNNNNNNNNNNNNNNNNNNNN**

**NEXT LINE SHOWS INTENSIFIED DISPLAY.
I I I I I I I I I I I I I I I I I I**

**NEXT LINE SHOWS REVERSE DISPLAY.
RRRRRRRRRRRRRRRRRRRRRRRRRRRRRRRRRRR**

**NEXT LINE SHOWS BLINKING DISPLAY
BBBBBBBBBBBBBBBBBBBBBBBBBBBBBBBBBB**

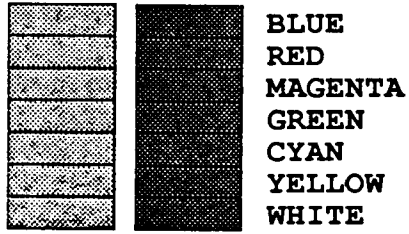

PRESS [ENTER] KEY

Subtest 03 Character set

In this subtest the character set of its code (00H to FFH) is displayed in the 40 x 25 character mode as shown below.

CHARACTER SET IN 40X25

```

☐☐♥♦+♣•◻○◊♯♀♂♠♣▶◀!@!#%&_▬↑↓→←⇐⇨▲▼?!"#$%&'
() *+ , - . / 0 1 2 3 4 5 6 7 8 9 : ; < = > ? @ A B C D E F G H I J K L M N O
P Q R S T U V W X Y Z [ \ ] ^ _ ` a b c d e f g h i j k l m n o p q r s t u v w
x y z { | } ~ ^ S u é á à å ä æ ç è é ê ë ì í î ï Æ Å Æ œ Æ ð ò ó ô ù ÿ Ö Ü ç £ ¥ P t f
â ï ó ù ñ Ñ ä ö ç ç ã ã ã ã ã ã ã ã ã ã ã ã ã ã ã ã ã ã ã ã ã ã ã ã ã ã ã ã ã ã ã ã
" " " " " " " " " " " " " " " " " " " " " " " " " " " " " " " " " " " " " " " " " "
≡ ± ≥ ≤ √ ∫ ∂ ≈ ° ∙ √n ∙
```

PRESS [ENTER] KEY

Subtest 06 640*200 Graphics display

This subtest displays the color blocks for the black and white display in the 640*200 dots graphics mode (Mode 6) as shown below.

640*200 GRAPHICS DISPLAY [6]
EVEN DOTS ODD DOTS ALL DOTS
DRIVEN DRIVEN DRIVEN

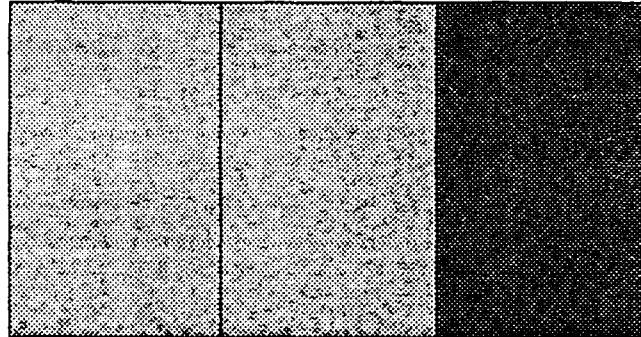

PRESS [ENTER] KEY

Subtest 07 640*400 Graphics display

This subtest displays the color blocks for the black and white display in the 640*400 pixels graphics mode (Mode 74) as shown below.

640*400 GRAPHICS DISPLAY : [74]
EVEN DOTS ODD DOTS ALL DOTS
DRIVEN DRIVEN DRIVEN

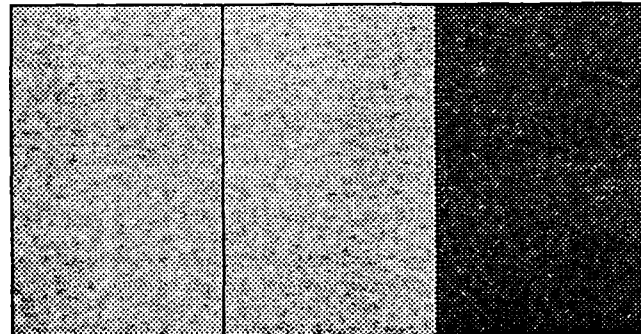

PRESS [ENTER] KEY

3.8 FLOPPY DISK TEST

CAUTION: Before running the floppy disk test, prepare a formatted work disk and remove the diagnostics disk. Then insert the work disk into the FDD. Because the contents of the floppy disk will be erased.

OPERATION

1. When you select the floppy disk test of the DIAGNOSTIC TEST MENU, the following message will appear under the DIAGNOSTIC TEST MENU.

Test drive number select (1:FDD1,2:FDD2,0:FDD1&2) ?

2. Select the test drive number, then press the **Enter**. The following message will appear.

Media in drive#1 mode (0:2DD,1:2D,2:2D-2HD/2DD,3:2HD) ?

3. Select the media type of the floppy disk to be tested, then press the **Enter**. The following message will appear.

Test start track (Enter:0/dd:00-79) ?

4. You can select the start track number of the floppy disk test.
When pressing the **Enter** only, the start track number will be zero.
If you desire, select the start track number. Then the subtest menu of the floppy disk test will appear.

5. During the floppy disk test, the message shown below will appear. The **ADDRESS** number indicates that the first **XX** shows a cylinder number, the third **X** shows a head number, and the last **XX** shows a sector number.
The **STATUS** number indicates that the first **X** shows a drive number and the last **XX** shows an error status code.

FLOPPY DISK

XXXXXXXX

SUB-TEST	: XX		
PASS COUNT	: XXXXX	ERROR COUNT	: XXXXX
WRITE DATA	: XX	READ DATA	: XX
ADDRESS	: XXXXX	STATUS	: XXX

CONTENTS

Subtest 01 Sequential read

This test performs the CRC (cyclic redundancy check) with a continuous read operation of all tracks on a floppy disk.
2D (Double-sided, double-density): Track 0 to 39.
2DD (Double-sided, double-density, double-track) and 2HD (Double-sided, high-density, double-track): Track 0 to 79.
The start track can be specified at the previous stage.

Subtest 02 Sequential read/write

This test writes data to all tracks (as defined above) continuously and then reads the data out and compares it with the original data. (The data pattern is B5ADADH repeated.)

Subtest 03 Random address/data

This test writes random data to random address on all tracks (as defined in subtest 01) and then reads the data out and compares it with the original data.

Subtest 04 Write specified address

This test writes the specified data on the specified address that you enter from the keyboard. You can specify the test data, track number, and head number.

Subtest 05 Read specified address

This subtest performs read operation on the specified address that you enter from the keyboard. You can specify the track number and head number.

OPERATION

Subtest 01 and 02

1. When you select the subtest 01 or 02, the following message will appear.

Select the channel number (1-3) ?

Select the printer channel number, then type in the number. The T3100e supports three printer channels.

2. After pressing the **Enter**, the subtest is executed.

Subtest 03

1. When you select this subtest, the following message will appear.

Select the channel number (1-3) ?

Select the printer channel number, then type in the number. The T3100e supports three printer channels.

2. After pressing the **Enter**, this subtest is executed.

3.10 ASYNC TEST

In subtest 01 to subtest 05, data transmission is done with the following format:

Speed: 9600 BPS
Data 8 bits and one parity bit (EVEN)
One stop bit
Data pattern: 20H to 7EH

Subtest 01 Wrap around (board)

NOTE: The RS-232-C wraparound connector must be connected to channel 1 to execute this test. The wiring diagram of the RS-232-C wraparound connector is described in part 3.25.

A data send/receive test is performed with the wraparound connector for the channel 1.

Subtest 02 Board (#1) <=> board (#2)

NOTE: The RS-232-C direct cable (9-pin to 9-pin) must be connected to channel 1 and 2 to execute this test. The wiring diagram of the RS-232-C direct cable is described in part 3.25.

The same test as the subtest 01 is performed for the channel #1 <=> #2

Subtest 03 Point to point (send)

NOTE: This subtest must be executed in condition that two machines are connected with the RS-232-C direct cable and one side should be set as 'send' and the other set as 'receive'. The wiring diagram of the RS-232-C direct cable is described in part 3.25. The subtest 03 executed in one side and the subtest 04 executed in the other will check the communication capability as follows:

A block of data (20H to 7EH) is sent from one side to the other, and then returned back. The returned data is compared with the original one. This test is used to check whether the returned data are same as the original ones.

Subtest 04 Point to point (receive)

This subtest is used with the subtest 03 as described above.

Subtest 05 110/300/1200 BPS card modem loopback

NOTE: If there is no modem card in the system, this test can no be executed.

This subtest is used to check whether the data to be sent from the modem card to the RS-232-C line is correct or not. This can be done with the loopback function inside the modem card.

Subtest 06 110/300/1200 BPS card modem on-line test

NOTE: This test requires two machines which are connected to the PBX (Private Branch Exchange). One side is set as 'send' and the other set as 'receive'. When both sides are ready, you can start the test.

In this subtest, data are sent from the 'send' side to the 'receive' side through the PBX. This subtest is used to check whether data transmission through a telephone line is done properly or not.

Subtest 07 Dial tester test

NOTE: To execute this subtest, a dial tester must be connected to the system.

This subtest is carried out by sending the pulse dial and tone dial twice automatically.

[Pulse dial]: "1-2-3-4-5-6-7-8-9-0-1-2"
[Tone dial]: "1-2-3-4-5-6-7-8-9-*0-#"

Subtest 08 Interrupt test (IRQ4, 3, 5)

This subtest generates the interrupt request levels 4, 3, 5 in this order, then checks if this function works correctly.

3.11 HARD DISK TEST

CAUTION: The contents of the hard disk will be erased when subtest 02, 03, 04, 06, 08, 09, or 10 is run. Before running the test, transfer the contents of the hard disk on the floppy disk. This can be done with the MS-DOS BACKUP command. After the test, enter the MS-DOS FDISK command, which will set the partition. Then enter the MS-DOS FORMAT command. (See the MS-DOS manual for details.)

OPERATION

1. When you select the hard disk test of the DIAGNOSTIC TEST MENU, the following message will appear.

Test drive number select (1:HDD1,2:HDD2,0:HDD1&2) ?
2. Select the drive number of the hard disk to be tested and press the **Enter**. The following message will appear.

HDC F/W error retry (1:yes,2:no) ?
3. This message is used to select whether to do retry operation or not when the hard disk controller detects an error. Select yes or no and press the **Enter**. The following message will appear.

Data compare error dump (1:no,2:yes) ?
4. This message is used to select whether to do dump operation or not when data compare error is detected. Select yes or no and press the **Enter**. The following message will appear.

Detail status display (1:no,2:yes) ?
5. This message is used to select whether to display the detail status on the screen or not. The detail status are described in section 3.16. Select yes or no and press the **Enter**.

6. During the hard disk test, the message shown below will appear. The **ADDRESS** number indicates that the first **XXX** shows a cylinder number, the fourth **X** shows a head number, and the last **XX** shows a sector number. The **STATUS** number indicates that the first **X** shows a drive number and the last **XX** shows an error status code.

```

HARD DISK TEST                                XXXXXXXX

SUB-TEST    : XX
PASS COUNT : XXXXX      ERROR COUNT : XXXXX
WRITE DATA : XX        READ DATA  : XX
ADDRESS    : XXXXXX     STATUS      : XXX

```

CONTENTS

Subtest 01 Sequential read

This subtest performs forward reading of contents from track 0 to Max. track and then performs reverse reading of the contents from Max. track to track 0.

Subtest 02 Address uniqueness

1. Selecting this subtest, the following message will appear.

Read sequential select ?

```

1 : Forward sequential
2 : Reverse sequential
3 : Random

```

2. Select one of the above and press the **Enter**.

This subtest writes the address data that is different sector by sector at each track, then reads and compares it to the original data. This test is done for all tracks.

Subtest 03 Random address/data

This subtest writes random data to random addresses (cylinder, head, sector) and then reads the data out and compares it to the original data.

Subtest 04 Cross talk & peak shift

This subtest writes the eight types of worst pattern data (shown below) to cylinders then reads the data while shifting cylinder by cylinder.

Worst pattern data

1. B5ADAD
2. 4A5252
3. EB6DB6
4. 149249
5. 63B63B
6. 9C49C4
7. 2DB6DB
8. D24924

Subtest 05 Write/Read/Compare (CE)

This subtest writes B5ADAD worst pattern data to the CE cylinder and then reads the data out and compares it with the original data.

Subtest 06 Write specified address

This subtest writes specified data to a specified cylinder and head.

Subtest 07 Read specified address

This subtest reads data which has been written to a specified cylinder and head.

Subtest 08 ECC circuit (CE cylinder)

This subtest checks the ECC (Error check and correction) circuit functions to a specified cylinder and head.

Subtest 09 Sequential write

This subtest writes specified data of the two bytes to all cylinder.

Subtest 10 W-R-C specified address

This subtest writes specified data to the specified cylinder and head, then read and compare with original data.

3.12 REAL TIMER TEST

Subtest 01 Real time

A new date and time can be input during this subtest when the current date and time are displayed.

Operations for the test are as follows.

1. Selecting the subtest, the following message will appear.

REAL TIME TEST

901000

Current data: XX-XX-XXXX

Current time: XX:XX:XX

Enter new date:

PRESS [ENTER] KEY TO EXIT TEST

2. If current date is not correct, input the current new date. Press the **Enter**, the enter new time:message will appear.
3. If current time is not correct, input the current new time. Press the **Enter**, return to the subtest menu of the REAL TIME TEST.

Subtest 02 Backup memory

This subtest writes data (AAH, 55H) to 50 bytes of the backup memory, and then reads and compares it with the original data.

Subtest 03 Real time carry

CAUTION: When this test is executed, the current date and time is erased.

This subtest checks whether the real time clock increments the time displayed correctly (month, day, year, hour, minute, second).

3.13 NDP TEST

CAUTION: This test cannot be run if there is no NDP mounted on the system BOARD.

Subtest 01 NDP test

This subtest checks the control word, status word, bus, and addition/multiplication functions.

3.14 EXPANSION UNIT TEST

NOTE: If there is no expansion unit connected to the system, this test cannot be executed.

Subtest 01 Box wrap around (8 bits bus)

NOTE: As this subtest required a special tool to be executed, it cannot be carried out here.

Subtest 02 Box mono video RAM

NOTE: If there is no monochrome display card in the expansion unit, this test cannot be executed.

This subtest writes data (FF, AA, 55, 00H) into the monochrome display memory (B0000H to B0F9FH), then reads the data out and compares it with the original data.

Subtest 03 Wrap around test (16 bit bus)

NOTE: As this subtest requires a special tool to be executed, it cannot be carried out here. If you execute the this subtest, the expansion memory not connect to the system board.

3.15 ERROR CODE AND ERROR STATUS NAMES

Table 3-3 lists the error code and error status names.

Table 3-3 Error code and error status names

Test name	Error code	Error status name
EVERYTHING	FF	Compare Error
SYSTEM	01	ROM Checksum Error
MEMORY	01	Parity Error
	02	Protected Mode Not Change
FDD	01	Bad Command
	02	Address Mark Not Found
	03	Write Protected
	04	Record Not Found
	06	Media Removed
	08	DMA Overrun Error
	09	DMA Boundary Error
	10	CRC Error
	20	FDC Error
	40	Seek Error
	60	FDD Not Drive
	80	Time Out Error (Not Ready)
	EE	Write Buffer Error
ASYNC	01	DSR Off Time Out
	02	CTS Off Time Out
	04	RX-Enable time out
	08	TX Buffer Full Time Out
	10	Parity Error
	20	Framing Error
	40	Overrun Error
	80	Line Status Error
	88	Modem Status Error
	33	No Carrier (CARD MODEM)
	34	Error (CARD MODEM)
	36	No Dial Tone (CARD MODEM)

Table 3-3 Error code and error status names (continued)

Test name	Error code	Error status name
PRINTER	01	Time Out
	08	Fault
	10	Select Line
	20	Out Of Paper
	40	Power Off
	80	Busy Line
HDD	01	Bad Command Error
	02	Bad Address Mark
	04	Record Not Found
	05	HDC Not Reset
	07	Drive Not Initialize
	09	DMA Boundary Error
	0A	Bad Sector Error
	0B	Bad Track Error
	10	ECC Error
	11	ECC Recover Enable
	20	HDC Error
	40	Seek Error
	80	Time Out Error
	AA	Drive Not Ready
	BB	Undefined
CC	Write Fault	
E0	Status Error	
F0	Not Sense Error (HW.code=FF)	
NDP	01	Not Co-processor
	02	Control Word Error
	03	Status Word Error
	04	Bus Error
	05	Addition Error
	06	Multiply Error

3.16 HARD DISK TEST DETAIL STATUS

When an error occurs on the hard disk test, the following message will appear.

HDC status = XXXXXXXX

Detailed status of the hard disk test error is shown on the screen by eight-unit number. The first **XXXX** is error status and the last **XXXX** is not used.

Error status is composed of 2 bytes; the first byte shows the contents of the HDC status register in hexadecimal form and the other the error register of the HDC.

These contents are described in the table 3-4 and 3-5.

Table 3-4 HDC status register contents

Bit	Name	Description
7	BSY (busy)	"0" ... HDC is busy. "1" ... HDC is ready.
6	DRDY (drive ready)	"0" ... Hard disk drive is not ready to accept any command. "1" ... Hard disk drive is ready.
5	DWF (drive write fault)	"0" ... DWF error is not detected. "1" ... Write fault condition occurs.
4	DSC (drive seek complete)	"0" ... The head disk drive leads are not settled over a track. "1" ... The hard disk drive heads are settled over a track.
3	DRQ (data request)	"0" ... Drive is not ready to transfer data. "1" ... Drive is ready for data transfer.
2	CORR (corrected data)	"0" ... Otherwise "1" ... Correctable data error is corrected.
1	IDX (index)	"0" ... Otherwise "1" ... Index is sensed.
0	ERR (error)	"0" ... Otherwise "1" ... The previous command was terminated with some error.

Table 3-5 Error register contents

Bit	Name	Description
7	BBK (bad block mark)	"0" ... Otherwise "1" ... A bad block mark is detected.
6	UNC (uncorrectable)	"0" ... There is no uncorrectable data error. "1" ... Uncorrectable data error has been detected.
5		Not used.
4	IDNF (identification)	"0" ... Otherwise "1" ... There was no ID field in the requested sector.
3		Not used.
2	ABRT (abort)	"0" ... Otherwise "1" ... Illegal command error or a drive status error occurs.
1	TK0 (track 0)	"0" ... The hard disk has found track 0 during a recalibrate command. "1" ... The hard disk could not find track 0 during a recalibrate command.
0		Not used.

3.17 HARD DISK FORMAT

There are two types of hard disk formatting:

1. Physical formatting
2. Logical formatting

This program is for physical formatting of the hard disk; it can execute the following items.

1. All track FORMAT
2. Good track FORMAT
3. Bad track FORMAT
4. Bad track CHECK

CAUTION: The contents of the hard disk will be erased when this program is run. Before running the program, transfer the contents of the hard disk on to a floppy disk. This can be done with the MS-DOS BACKUP command. (See the MS-DOS manual for details.)

3.17.1 Program description

1. All track FORMAT

Performs physical formatting of hard disk in the manner shown below.

	20-Mbyte	40-Mbyte
Sector sequences:	1	1
Cylinders:	0 to 614	0 to 979
Heads:	0 to 2	0 to 4
Sectors:	0 to 16	0 to 16
Sector length: (bps)	512	512

2. Good track FORMAT

Executes the formatting of a specified cylinder and track as a good track.

3. Bad track FORMAT

Executes the formatting of a specified cylinder and track as a bad track.

4. Bad track CHECK

Checks for bad tracks by performing a read operation for all tracks on the hard disk; a list of bad tracks is then displayed

3.17.2 Operations

CAUTION: After physical formatting is finished, enter the MS-DOS FDISK command, which will set the partition. Then enter the MS-DOS FORMAT command. (See the MS-DOS manual for details.)

1. After pressing **2** and **Enter** in the DIAGNOSTICS MENU, the following display will appear.

DIAGNOSTIC - HARD DISK FORMAT V2.00

- 1 - All track FORMAT**
- 2 - Good track FORMAT**
- 3 - Bad track FORMAT**
- 4 - Bad track CHECK**
- 9 - Exit to DIAGNOSTICS MENU**

Press [NUMBER] key ?

2. All track FORMAT Selection

- (1) When all track FORMAT(1) is selected, the following message will appear.

Drive number select (1:#1, 2:#2) ?

- (2) Select a drive number. Type the drive number and press **Enter**. The following message will appear.

Interleave number (3/1-3) ?

- (3) Select an interleave number. (Usually select 3.) Type the number and press **Enter**. The following display will appear.

```
[HDD TYPE] : CYLINDER = XXX
[HDD TYPE] : HEAD     = X
[HDD TYPE] : SECTOR   = XX
```

[WARNING : Current DISK data will be completely destroyed]

Press [Bad track number (CCCH) key ?
[[cylinder, head = XXX X]]

- (4) After pressing the **Enter**, the **[[cylinder, head = XXX X]]** message will appear; then all cylinders of the hard disk are formatted and checked.

- (5) After formatting the hard disk, the **Format complete** message will then appear.
 - (6) Press the **Enter** to return to the HARD DISK FORMAT menu.
3. Good track FORMAT or Bad track FORMAT Selection
- (1) When Good track FORMAT or Bad track FORMAT is selected, the following message will appear.
Drive number select (1:#1, 2:#2) ?
 - (2) Select a drive number. Type the drive number and press **Enter**. The following message will appear.
Interleave number (3/1-3) ?
 - (3) Select an interleave number. (Usually select 3.) Type the number and press **Enter**. The following message will appear.
[HDD TYPE] : CYLINDER = XXX
[HDD TYPE] : HEAD = X
[HDD TYPE] : SECTOR = XX
Press [track number (CCCH)] key ?
 - (4) Type a track number (four digits) and press **Enter**. (The first three digits are the cylinder number and the last digit is the head number.) This executes the formatting of good tracks or bad tracks.

NOTE: This program can format only one track per operation. If it is desired to format several good tracks or bad tracks, repeat the operation as many times as necessary.
 - (5) After formatting the track of the hard disk, the **Format complete** message will appear.
 - (6) Press the **Enter** to return to the HARD DISK FORMAT menu.

4. Bad track CHECK Selection

- (1) When Bad track CHECK is selected, the following message will appear.

Drive number select (1:#1, 2:#2) ?

- (2) Select a drive number. Type the drive number and press **Enter**. The following message will appear.

Interleave number (3/1-3) ?

- (3) Select an interleave number. (Usually select 3.) Type the number and press **Enter**.
When the following message appears, and bad tracks of the hard disk are checked.

```
[HDD TYPE] : CYLINDER = XXX
[HDD TYPE] : HEAD     = X
[HDD TYPE] : SECTOR   = XX
```

[[cylinder,head = XXX XX]]

- (4) After checking the bad tracks of the hard disk, the **Format complete** message will appear.
- (5) Press the **Enter** to return to the HARD DISK FORMAT menu.

3.18 SEEK TO LANDING ZONE (HDD)

3.18.1 Program description

When moving the unit, if an HDD head hits a data area severely, the data will be lost. In order to protect the data, this program moves HDD heads to safe areas. These areas called "landing zone".

NOTE: The built-in hard disk drive controls automatically the heads to move to the landing zone at power down.

3.18.2 Operations

1. After pressing **3** and **Enter** in the DIAGNOSTICS MENU, the program is automatically executed and the following message will appear.

Landing seek completed. (HDD#1)
Press [Enter] key.

2. After pressing **Enter**, the DIAGNOSTICS MENU appears.

3.19 HEAD CLEANING

3.19.1 Program description

This program executes head loading and seek/read operations for head cleaning. A cleaning kit is necessary for cleaning the FDD head.

3.19.2 Operations

1. After pressing **4** and **Enter** in the DIAGNOSTICS MENU, the following message will appear.

DIAGNOSTIC FLOPPY DISK HEAD CLEANING: VX.XX

**Mount cleaning disk(s) on drive(s).
Press any key when ready.**

2. After above message appears, remove the Diagnostics disk, insert the cleaning disk, and press any key.
3. When the **Cleaning start** message appears, FDD head cleaning will begin.
4. When cleaning is finished, the display automatically returns to the DIAGNOSTICS MENU.

3.20 LOG UTILITIES

3.20.1 Program description

This program logs error information generated, while a test is in progress; the information is stored in the RAM. However if the POWER switch is turned off the error information will be lost. The error information itself is displayed as the following.

1. Error count (CNT)
2. Test name (TEST)
3. Subtest number (NAME)
4. Pass count (PASS)
5. Error status (STS)
6. Address (FDD, HDD 1 or memory; ADDR)
7. Write data (WD)
8. Read data (RD)
9. Error status name

This program can store data on a floppy disk or output information to a printer.

3.20.2 Operations

1. After pressing **5** and **Enter** in the DIAGNOSTICS MENU, the error information logged in the RAM or on the floppy disk is displayed as shown below.

XXXXX ERRORS

CNT	TS-NAME	PASS	STS	ADDR	WD	RD	HSTS	[ERROR STATUS NAME]
001	FDD 02	0000	103	00001	00	00	FDD -	WRITE PROTECTED
001	FDD 01	0000	180	00001	00	00	FDD -	TIME OUT ERROR

Error count Test name Subtest number Pass count Error status Address Write data Read data Error status name

[[1:Next, 2:prev, 3:Exit, 4:Clear, 5:Print, 6:FD LogRead, 7:FD LogWrite]]

2. Error information displayed on the screen can be manipulated with the following key operation.

The 1 key scrolls the display to the next page.
 The 2 key scrolls the display to the previous page.
 The 3 key returns the display to the DIAGNOSTIC MENU.
 The 4 key erases all error log information in RAM.
 The 5 key outputs error log information to a printer.
 The 6 key reads log information from a floppy disk.
 The 7 key writes log information to a floppy disk.

3.21 RUNNING TEST

3.21.1 Program description

This program automatically runs the following tests in sequence.

1. System test (subtest number 01)
2. Memory test (subtest number 01, 02, 03, 04, 06)
3. Display test (subtest number 01 to 08)
4. FDD test (subtest number 02)
5. Printer test (subtest number 03)
6. Async test (subtest number 01)
7. HDD test (subtest number 01, 05)
8. Real timer (subtest number 02)

When running an FDD test, this system automatically decides whether there are one or two FDDs.

3.21.2 Operations

CAUTION: Do not forget to load a work disk. If a work disk is not loaded, an error will be generated during FDD testing.

1. Remove the diagnostics disk and insert the work disk into the floppy disk drive.
2. After pressing **6** and **Enter** in the DIAGNOSTIC MENU, the following message will appear.

Printer wrap around test (Y/N) ?
3. Select whether to execute the printer wraparound test (Yes) or not (No). Type **Y** or **N** and press **Enter**. (If Y is selected, a wraparound connector must be connected to the printer connector on the back of the unit.) The following message will appear.

Async#1 wrap around test (Y/N) ?
Async#2 wrap around test (Y/N) ?
4. Select whether to execute the test (Yes) or not (No). Type **Y** or **N** and press **Enter**. (If Y is selected, an RS-232-C wraparound connector must be connected to the SER. A or SER. B connector on the back or right side of the unit.)
5. This program is repeated continuously. To stop the program, press **Ctrl + Break**.

3.22 FDD UTILITIES

3.22.1 Program description

These programs format and copy floppy disks, and display dump list for both the FDD and the HDD.

1. FORMAT

CAUTION: The program is for only floppy disk drive test. The program is different the MS-DOS FORMAT command.

This program can format floppy disk (5.25-inch/3.5-inch) as follows.

- (1) **2D:**Double-sided, double-density, 48/67.5 TPI, MFM mode, 512 bytes, 9 sectors/track.
- (2) **2DD:**Double-sided, double-density, double-track, 96/135 TPI, MFM mode, 512 bytes, 9 sectors/track.
- (3) **2HD:**Double-sided, high-density, double-track, 96/135 TPI, MFM mode, 512 bytes, 18 sectors/track.

2. COPY

This program copies from source floppy disk to target floppy disk.

3. DUMP

This program displays the contents of floppy disks (both 3.5" and 5.25") and hard disk (designated sectors).

3.22.2 Operations

1. After pressing 7 and Enter key in the DIAGNOSTICS MENU, the following display will appear before program execution.

[FDD UTILITIES]

1 : FORMAT
2 : COPY
3 : DUMP
4 : EXIT TO DIAGNOSTICS MENU

PRESS [1] - [9] KEY

2. FORMAT Selection

- (1) When FORMAT is selected, the following message appears.

```
DIAGNOSTICS - FORMAT(V1.00)  
Drive number select (1:A, 2:B) ?
```

- (2) Select a drive number. Type the number and the following message will then appear.

```
Type select (0:2DD-2DD,1:2D-2DD,2:2D-2HD,3:2HD-2HD) ?
```

- (3) Select a media-drive type number. Type the number and the message similar to the below will appear.

```
Warning : Disk data will be destroyed.
```

```
Insert work disk in to drive A :  
Press any key when ready.
```

- (4) Remove the diagnostics disk from the FDD and insert the work disk; press any key.
The following message will appear; formatting is then executed.

```
[FDD TYPE] : TRACK      = XXX  
[FDD TYPE] : HEAD       = X  
[FDD TYPE] : SECTOR     = XX
```

```
Format start
```

```
[[track, head = XXX X]]
```

After the floppy disk is formatted, the following message will appear.

```
Format complete  
Another format (1:Yes/2:No) ?
```

- (5) If you type **1** and press **Enter** key, the display will return to the message in (3) above. If you type **2** the display will return to the DIAGNOSTICS MENU.

3. COPY Selection

- (1) When COPY is selected, the following message will appear.

DIAGNOSTICS - COPY
Type select (0:2DD-2DD,1:2D-2D,2:2D-2HD,3:2HD-2HD) ?

- (2) Select a media/drive type number. Type the number. The following message will then appear.

Insert source disk into drive A :
Press any key when ready.

- (3) Remove the diagnostics disk from the FDD and insert the source disk; press any key. The following message will appear, then start the copy to memory.

[FDD TYPE] : TRACK = XXX
[FDD TYPE] : HEAD = X
[FDD TYPE] : SECTOR = XX

Copy start
Insert target disk into drive A
Press any key when ready.

[[track, head = XXX XX]]

- (4) Remove the source disk from the FDD and insert the work disk (formatted); press any key. The **[[track, head = XXX X]]** message will appear, then start the copy to work disk. When coping cannot be done with one operation, message (2) is displayed again. Repeat the operation. After the floppy disk has been copied, the following message will appear.

Copy complete
Another copy (1:Yes/2:No) ?

- (5) If you type **1** the display will return to the message in (1) above. If you type **2** the display will return to the DIAGNOSTICS MENU.

4. DUMP Selection

- (1) When dump is selected, the following message will appear.

[HDD&FLOPPY DISK DATA DUMP]
format type select (0:2DD,1:2D,2:2HD,3:HDD) ?

- (2) Select a format type number. Type the number. If **3** is selected, the dump lists for the hard disk are displayed automatically.

0: Display a dump list for a floppy disk (2DD)
 1: Display a dump list for a floppy disk (2D).
 2: Display a dump list for a floppy disk (2HD).
 3: Displays a dump list for a hard disk.

- (3) If 0, 1, or 2 is selected, the following message will appear. If 3 is selected, the dump list will appear.

Select FDD number (1:A/2:B) ?

- (4) Select an FDD drive number; the following message will then appear.

Insert source disk into drive A :
Press any key when ready.

- (5) Remove the diagnostics disk from the FDD and insert a source disk; press any key. The **Track number ??** message will then appear. Type the track number and press **Enter**.

- (6) The **Head number ?** message will then appear. Type the head number and press **Enter**.

- (7) The **Sector number ??** message will then appear. Type the sector number and press **Enter**. The dump list for the floppy disk will be displayed.

- (8) After a dump list appears on the screen, the **Press number key (1:up,2:down,3:end) ?** message will appear.

1. Displays the next sector dump.
 2. Displays a previous sector dump.
 3. Displays the following message.

Another dump (1:Yes/2:No) ?

- (9) If you type **1** the display will return to the message shown after (4) above. If you type **2** the display will return to the DIAGNOSTICS MENU.

3.23 SYSTEM CONFIGURATION

3.23.1 Program description

This program displays the following system configuration.

1. BIOS ROM VERSION = VX.XX
2. Base memory size
3. Display type
4. A number of floppy disk drives
5. A number of async ports
6. A number of hard disk drives
7. A number of printer ports
8. Co-processor presents or not
9. Extended memory size

3.23.2 Operations

After pressing **8** and **Enter** key to select from the DIAGNOSTICS MENU, the following display will appear.

SYSTEM CONFIGURATION

- *- BIOS ROM VERSION = X.XX
- *- 640KB MEMORY
- *- PLASMA DISPLAY
- *- 1 FLOPPY DISK DRIVE(S)
- *- 2 ASYNC ADAPTER(S)
- *- 1 HARD DISK DRIVE(S)
- *- 1 PRINTER ADAPTER(S)
- *- 0 MATH CO-PROCESSOR
- *- 0000KB EXTENDED MEMORY

PRESS [ENTER] KEY

Press **Enter** key to return to the DIAGNOSTICS MENU.

3.24 SETUP

3.24.1 Accessing the SETUP

Press: 0 followed by **Enter**. You see this screen:

[[System setup]]

1. Hard disk drive = 11-Cyl=615,h=4, S/T=17,Cap=2OMB
2. Memory size
 - System memory = 640KB
 - Extended memory = OMB
 - Expanded memory = OMB+384KB
3. Internal KB type = 84 keys
4. Plasma font type = Single
5. Plasma font set = Standard
6. Display card = Internal CGA (80*25)
7. Card type in Expansion slot = None
8. Printer port type = Output port
9. Serial port
 - IRQ5 SIO base address = 3E8h
 - Serial A IRQ level = 4 (IRQ base address = 3F8h)
 - Serial B IRQ level = 3 (IRQ base address = 2F8h)
 - Optional port IRQ level = 5 (IRQ base address = 3E8h)

↑↓ moves between items, ←→ selects value
F1 exists, **F5** sets default, **F10** records changes

This menu above shows an example of setup options as they may be currently stored in memory.

Notice that selecting the type of diskette drive is not an option. The T3100e automatically determines what type of internal diskette drive is installed. Also, you don't have to run the SETUP to use an external 5 1/4" diskette drive. Press **F1** if the setup options displayed accurately reflect your hardware configuration and no changes are necessary. The system restarts.

3.24.2 Changing Setup Values

You can change the setup options automatically or manually.

Automatic Reset

Follow these steps to set the values automatically:

- 1 Press **F5**. This instructs the program to reset all the options to their factory preset values. The program calculates how much conventional, extended and expanded memory your T3100e has, based on whether or not you have a memory expansion board installed. Setup stores the value it calculates in configuration memory along with the factory preset values for the other options. The **[[System setup]]** menu displays the new values.
- 2 Confirm that the new values are correct. To change any option(s), go to the next section, *Manual Reset*.
- 3 If the new values are correct, press **F1**. The system restarts.

Manual Reset

Follow these steps to change any option(s) manually:

- 1 Notice the cursor (reverse display highlight bar). This cursor indicates which option is selected for change.
- 2 Use the up and down arrow keys (or **Enter**) to move the cursor between options.
- 3 When the cursor highlights the value of an option you want to change, use the left and right arrow keys to select alternate values. The possible values for each option are shown in the table below.
- 4 When you are finished making changes, press **F10** to record the new values in configuration memory.
- 5 SETUP displays this message:

ARE YOU SURE ? (Y/N)

Review your changes. If you need to make more alterations, press **N** and go back to step 2.

- 6 If the new values are correct, press **Y**. The system restarts.

3.24.3 SETUP Descriptions

This section explains the possible values for each SETUP option.

1. Hard Disk Type

As you change the values for this option using the right and left arrow keys, the setup program displays one of the following lines:

11 - Cyl= 615, H= 4, S/T= 17, Cap= 20MB
 12 - Cyl= 980, H= 5, S/T= 17, Cap= 40MB
 No Drive

Drive Table

<i>Abbreviation</i>	<i>Meaning</i>
Cyl	cylinder
H	head
S/T	sector/track
Cap	capacity

Select type 11 for the T3100e, or type 12 for the T3100e/40.

NOTE: Automatic Reset sets correct Hard Disk Type automatically, but once the CMOS configuration error occurs the default value is forced to type 11. In the case, you have to select type 12 for the T3100e/40 by Manual Reset.

2. Memory Size

Configuration memory involves selecting how much RAM the system uses for each of the three types of memory: System memory, Extended memory, and Expanded memory. You can set the size of the system memory either to 512KB or 640KB.

For the purposes of SETUP, the second and third memory types are interrelated. Use these guidelines to set **Extended memory** first:

- o Specify the size of extended memory in 0.5MB decrements from the maximum available to 0MB. The maximum memory you have depends on whether or not the memory expansion board is installed. The preset size of extended memory is the maximum available.
- o Each time you change the size of extended memory, you also change the size of expanded memory. Memory not used as extended memory is automatically allocated by the system as expanded memory. Here are two examples of how this procedure works:

Memory Example 1: You have the 2MB memory kit installed (there's a maximum of 2MB available for extended memory). You specify 0.5MB of extended memory. The system automatically allocates 1.5MB as expanded memory.

Memory Example 2: You have the memory kit installed (there's a maximum of 4MB available for extended memory). You specify 2MB of extended memory. The system automatically allocates 2MB as expanded memory.

- o Specify how you want to use the T3100e's remaining memory, usually 384KB. (This is the system memory not accounted for by the other figures; refer back to the discussion of memory types in this chapter for more information.) Set this value through the **Expanded memory** value of the **Memory size** option. You have these choices:

- blank** No additional memory is allocated for expanded memory. The only memory used as expanded memory is what was automatically assigned due to your choice for **Extended memory**. All remaining memory (except conventional memory) is used as extended memory.
- 384KB** All memory not otherwise allocated is reserved for expanded memory, in addition to memory allocated by your choice for **Extended memory**. If you set 512KB conventional memory, the amount of possible expanded memory increases by 128KB. Instead of 0KB and 384KB for these values, you have 0KB and 512KB, respectively.

- o These tables summarize the **Memory size** values:

Extended/Expanded Memory Size Table

Extended memory Values	Resulting Expanded Memory Size with 2MB memory kit
0MB	2MB
0.5MB	1.5MB
1MB	1MB
1.5MB	0.5MB
2MB	0MB

Find the amount of extended memory you wish to use in the first column. The second column shows you how much expanded memory your T3100e will have with the memory kit.

Additional Memory Table

Expanded memory size values	Total Extended Memory	Total Expanded
blank	384KB*+ value above	0KB+ value above
384KB	Value above	384KB*+ value above

*Setting system memory size to 512KB increases these values by 128KB.

3. Internal KB type

This option determines which keyboard scan codes the T3100e uses: the standard AT scan codes or enhanced AT scan codes.

84 Keys selects standard AT scan codes. This is the preset value.

101 Keys emulates the enhanced keyboard.

Select 84 keys unless your software requires the enhanced keyboard's scan codes.

NOTE: Set this option to 84 keys when using a keyboard other than the U.S.A. keyboard.

4. Plasma Font Type

This option specifies which display font the T3100e uses each time you start the system.

Single specifies light (single width) characters.
This is the preset value.

Double specifies heavy (double width) characters.

Use the **Fn** + right arrow to select the alternate character font after the system is running.

5. Plasma Font Set

This option specifies which character font the T3100e uses each time you start the system.

Standard specifies the standard North American character set. This is the preset value.
North European specifies the North European font.
Canadian French specifies the Canadian French font.
Reserved

6. Display Card

This option lets you define the types of internal or external display adaptor card you have attached to the T3100e. You only specify this option when you install an optional video card in one of the expansion slots. The setup program displays your choices a line at a time as follows:

Internal CGA (80*25)
Internal CGA (40*25)
External CGA (80*25)
External CGA (40*25)
External MDA (Internal CGA Enable)
External Other (Internal CGA Enable)
External MDA (Internal CGA Disable)
External Other (Internal CGA Disable)

Make a selection which corresponds to your hardware configuration. If you select a value which uses an external display card, you must install an external display controller and disable the internal display controller. The preset value is the first setting: **Internal CGA (80*25)**.

7. Card type In Expansion slot

This option specifies which type of option cards are to be used by the T3100e. (If you change this option, the new setting takes effect only after the T3100e is restarted.) The T3100e supports two types of expansion slots: the IBM PC 8-bit bus slot which can accommodate industry-standard 8-bit option cards for the IBM PC, and the Toshiba bus slot that can accommodate T3100e option cards. The T3100e supports four types of option cards.

None	No cards are installed in the expansion slot.
Toshiba Modem Card	A Toshiba modem card is installed in the expansion slot.
Interface Card for Toshiba expansion chassis	A Toshiba expansion chassis interface card is installed in the expansion slot.
Others	Another type of card is installed in the expansion slot.

8. Printer Port

This option specifies which type of parallel port is to be used. The T3100e's parallel port may be configured as either an output-only port or as an input/output port.

Output Port	specifies an output-only port. This is the preset value.
Bi-directional Port	specifies an input/output port.

9. Serial Port

This option allows you to change the I/O address of a serial port is automatically established according to its interrupt level, the SETUP program prompts you to specify only the interrupt level. The I/O address of a serial port which is given an interrupt level of 5, however, must be set to one of the two predetermined I/O addresses as shown below.

The relationship between the serial port interrupt levels and I/O addresses is shown below.

Interrupt Level	I/O Address
3	2F8H
4	3F8H
5	3E8H or 338H

The first setup item in the serial port setup menu sets the I/O address for the serial port that is to be given an interrupt level of 5. The SETUP program displays one of the following addresses as the possible I/O address:

3E8H 338H

You can select the appropriate ones with the left and right arrow keys.

The second through fourth items in the serial port setup menu set the interrupt levels of the serial ports.

When the cursor is positioned on the second serial port setup menu item, the SETUP program displays the menu shown below. From this menu, you can select the interrupt levels to be assigned to the serial ports.

The menu indicates the specified interrupt levels in reverse video. You can select the appropriate one with the left and right arrow keys. After selecting the interrupt levels, press the up or down arrow key, or the RETURN key. The menu will disappear and the original setup menu will reappear.

[Serial port setup menus]

```

Serial                = 4  4  3  3  4  3
Serial                = 3  5  4  5  -  -
Optional port IRQ level = 5  3  5  4  3  4

```

```

IRQ4 serial port base address = 3F8h
IRQ3 serial port base address = 2F8h
IRQ5 serial port base address = 3E8h

```

Example 1: When not using an expansion card.

The following serial port interrupt level settings are recommended:

```

Serial A IRQ level = 3
Serial B IRQ level = 4
Optional port IRQ level = 5

```

Example 2: When using a Toshiba modem card

When using a Toshiba modem card, you have to set the setup item Option 7, "Card type in Expansion slot," to specify "Toshiba Modem Card." You also need to set the optional port IRQ level according to the I/O address or interrupt level of the modem card that is specified by the communication software to be used. For example, set the serial port interrupt levels as shown below when the communications software assumes 2F8H as the I/O address of the modem.

```

Serial A IRQ level = 4
Serial B IRQ level = 5
Optional port IRQ level = 3
or
Serial A IRQ level = 4
Serial B IRQ level = -
Optional port IRQ level = 3

```

Example 3: When using a modem card for the IBM PC

When using a modem card for the IBMPC, you have to set the setup item Option 7, "Card type in Expansion slot." Set option 7 to "Others" when installing the modem card in the T3100e's expansion slot, and to "Toshiba expansion chassis" when installing the modem card in a Toshiba Expansion Chassis.

Then check the I/O address of the modem card and make sure that it does not conflict with that of the serial A and B. For example, set the serial port interrupt levels as shown below when the I/O address of the modem card is 2F8H.

Serial A IRQ level = 4
Serial B IRQ level = 5
Optional port IRQ level = 3

or

Serial A IRQ level = 4
Serial B IRQ level = -
Optional port IRQ level = 3

3.25 WIRING DIAGRAM

1. Printer wraparound connector

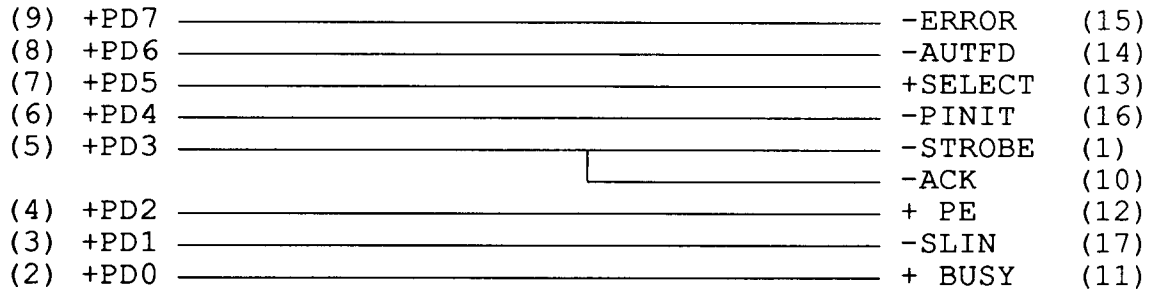

Figure 3-1 Printer wraparound connector

2. RS-232-C Wraparound connector

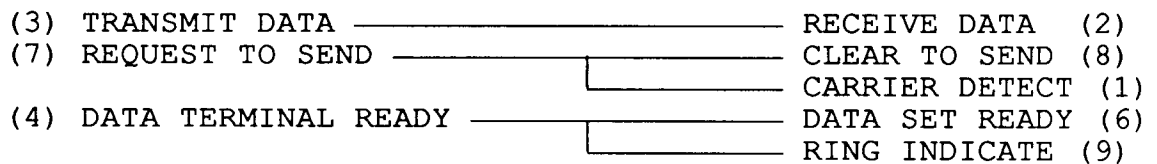

Figure 3-2 RS-232-C wraparound connector

3. RS-232-C direct cable (9-pin to 9-pin)

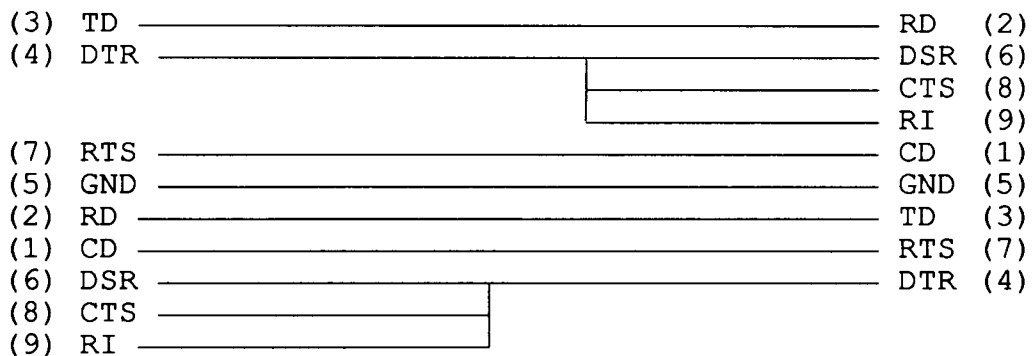

Figure 3-3 RS-232-C direct cable (9-pin to 9-pin)

4. RS-232-C direct cable (9-pin to 25-pin)

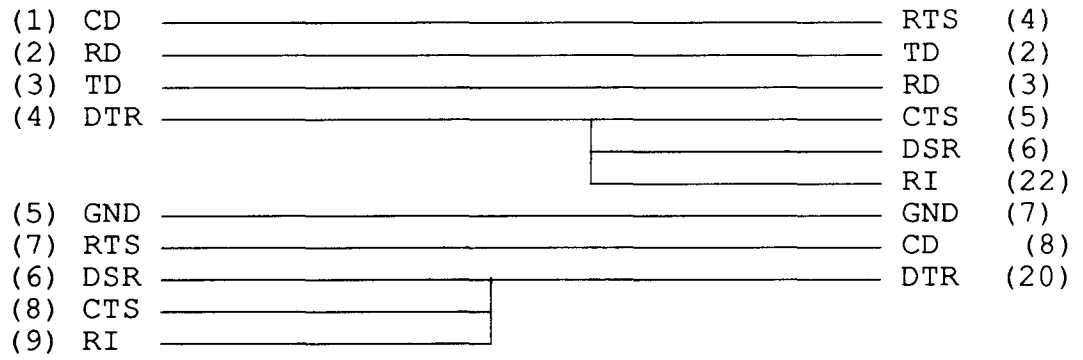

Figure 3-4 RS-232-C direct cable (9-pin to 25-pin)

4.1 GENERAL

This PART describes how to remove the following Field Replaceable Units (FRUs):

1. Keyboard
2. Speaker
3. Extension board
4. PDP (plasma display panel) mask
5. PDP unit
6. PDP cover
7. LED board
8. Top cover
9. Power supply unit
10. Power supply cover
11. Disk support
12. Plasma sensor
13. Lithium battery
14. FDD
15. HDD
16. Cooling fans
17. Cooling fan holder
18. Handle
19. System board

The following points must be kept in mind:

1. The system should never be disassembled unless there is a problem (abnormal operation, etc.)
2. Only approved tools may be used.
3. After deciding the purpose of replacing the unit, and the procedures required, do not carry out any other procedures which are not absolutely necessary.
4. Be sure to turn the power switch off before beginning.
5. Be sure to disconnect the AC cord and all external cables from the system unit.
6. Follow the only fixed, standard procedures.
7. After replacing a unit, confirm that the system is operating normally.

Tools needed for unit replacement:

1. Phillips head screwdriver.
2. Tweezers.

4.2 REMOVING/REPLACING THE KEYBOARD AND SPEAKER

1. Unplug the AC power cord from the system unit.
2. Turn the system unit upside down and stand the handle (A).
3. Remove the 3 screws (B).

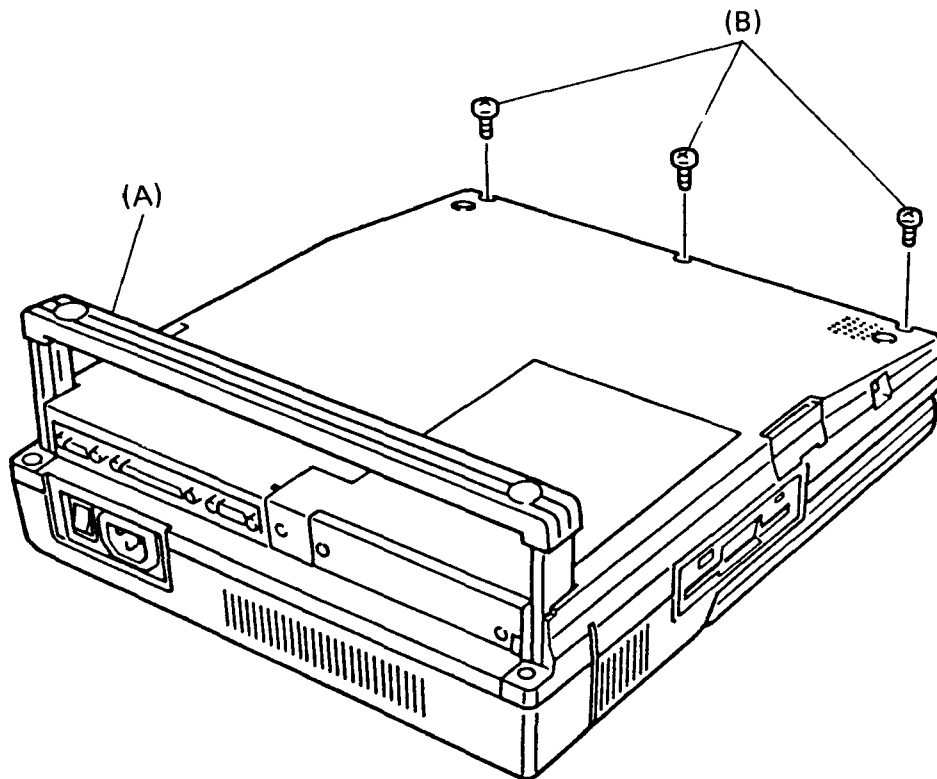

Figure 4-1 Base

4. Remove the keyboard (C) by disengaging from 6 latches (D) on the base (E).
5. Remove the shield plate (F) by removing 2 screws (G).
6. Disconnect the keyboard cable (H) from the system board (PJ3).

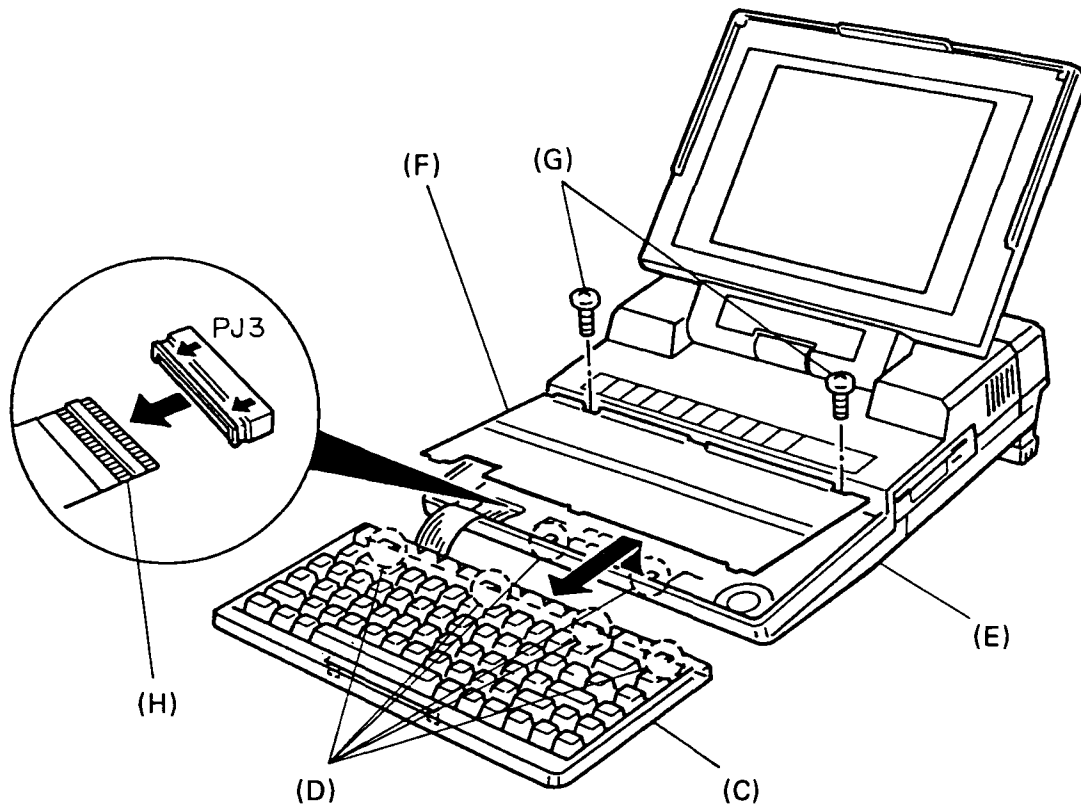

Figure 4-2 Keyboard and shield plate

7. Disconnect the speaker connector (I) from the system board, then remove the speaker (J) by disengaging from 2 tabs (K).

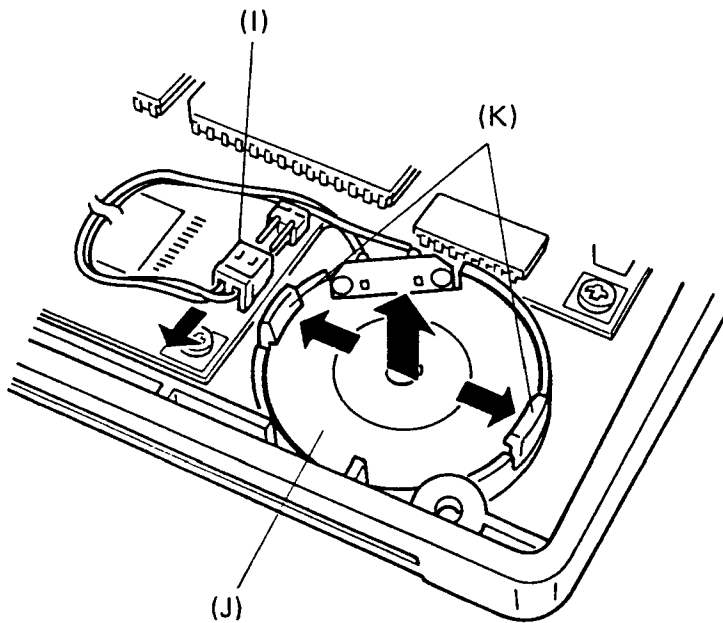

Figure 4-3 Speaker

8. Reverse procedure to install.

4.3 REMOVING/REPLACING THE T3100 SUPPORT BOARD

1. Unplug the AC power cord from the system unit.
2. Remove the mask panel (A) by removing 2 screws (B).
3. Remove the extension board cover (C) by removing screw (D), and disengaging from 2 latches (E) on the base (F).

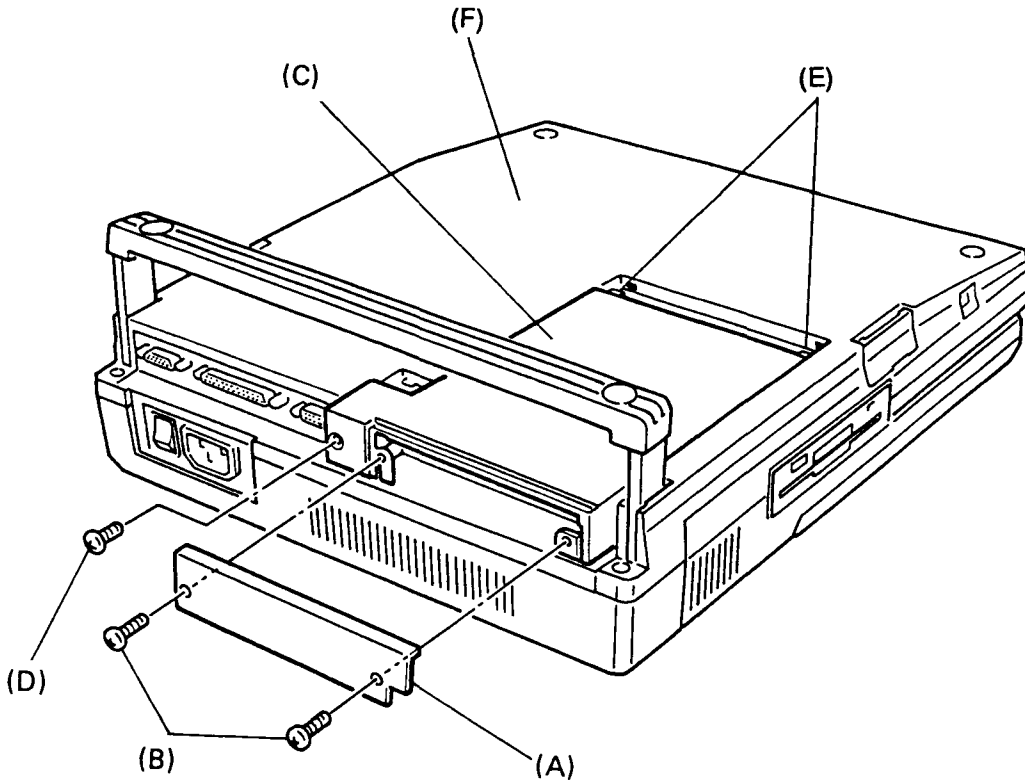

Figure 4-4 Extension board cover

4. Disconnect the system interface connector on the T3100 support board (G) from the system board, then remove the T3100 support board.

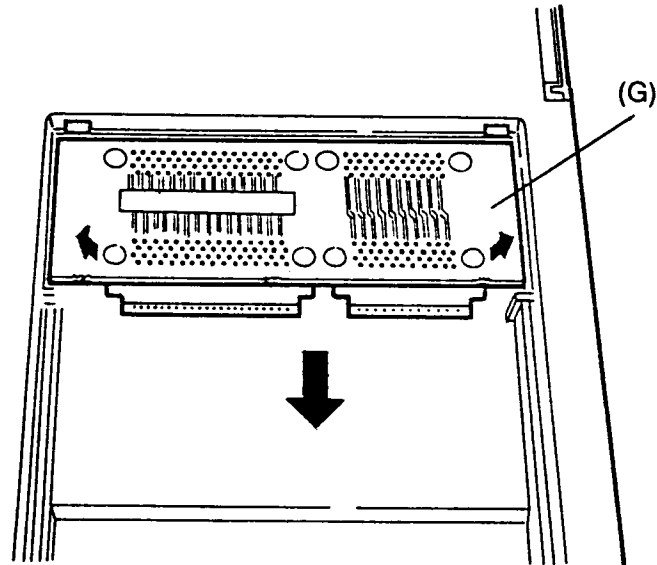

Figure 4-5 T3100 support board

4. Reverse procedure to install.

NOTE: To attach the IBM half size board (8-bit), use the big size's cover included in the package. To attach the Toshiba size card. Use the normal cover.

4.4 REMOVING/REPLACING THE PDP MASK

1. Unplug the AC power cord from the system unit.
2. Open the plasma display.
3. Using tweezers, peel off the label (A) and keep it in a clean place.
4. Remove 2 screws (B) fixing the PDP mask (C) by holding bottom (D) and lifting up.

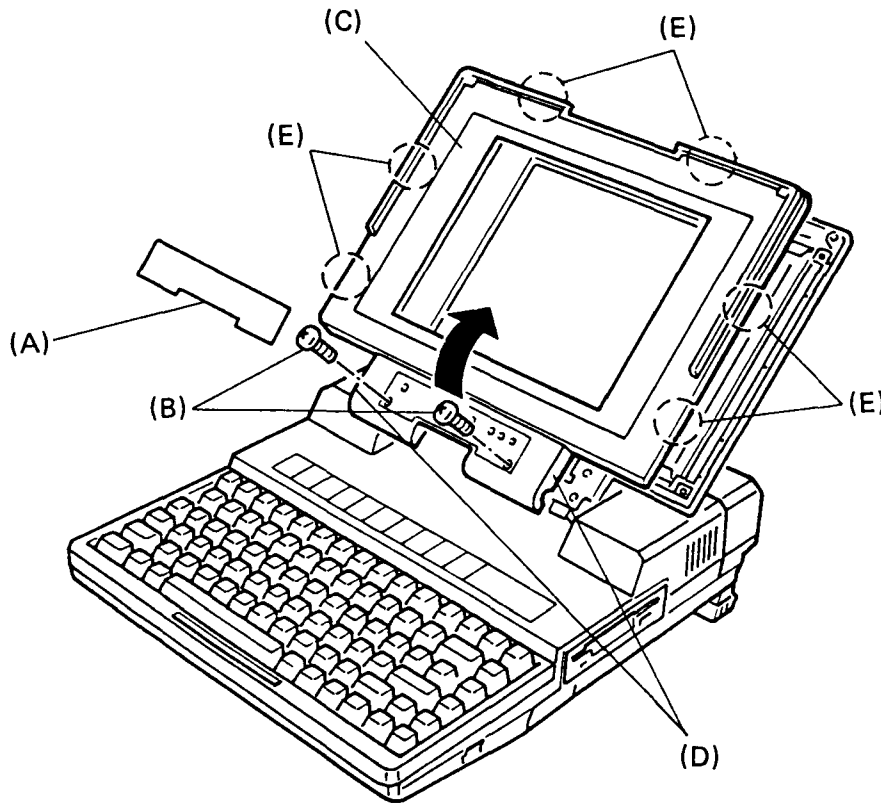

Figure 4-6 PDP mask

5. Reverse procedure to install.

NOTE: Confirm that the PDP mask is locked into the PDP cover with the six latches (E).

4.5 REMOVING/REPLACING THE PDP UNIT

1. Remove the PDP mask according to section 4.4.
2. Remove 4 screws (A), fixing the PDP unit (B).
3. Lift up the PDP unit, then gently put it on the keyboard.
4. Disconnect the three cables (C) from the plasma display board (D).

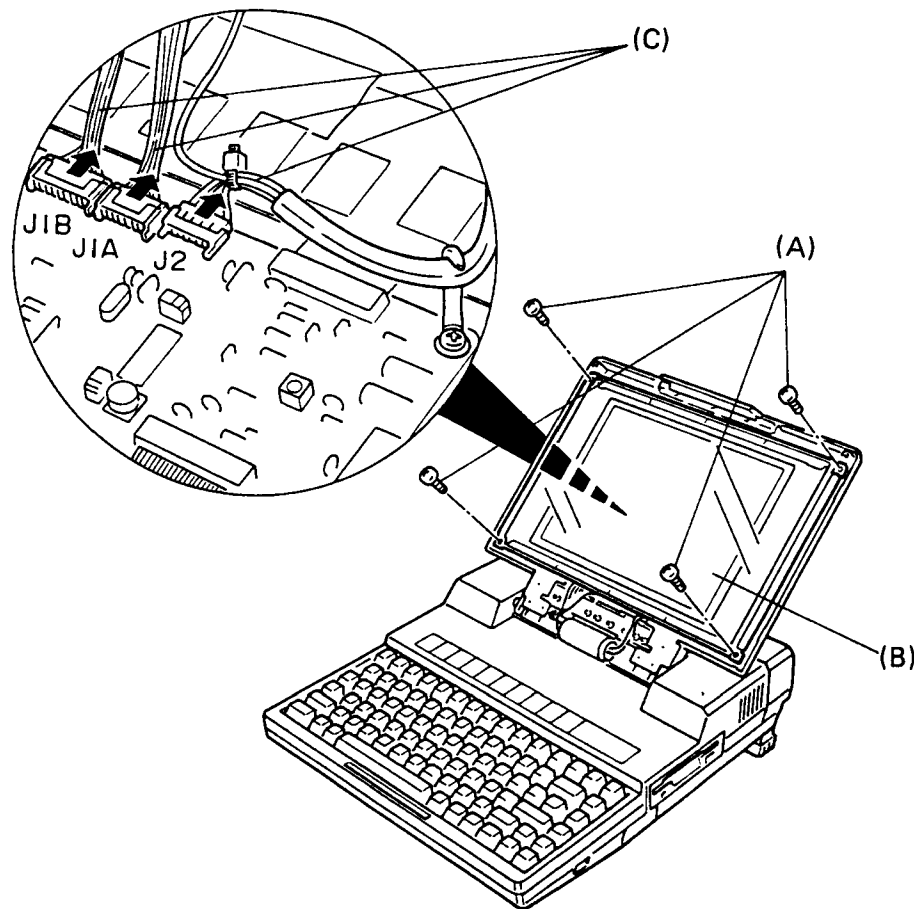

Figure 4-7 Removing the PDP unit

5. Reverse procedure to install.

4.6 REMOVING/REPLACING THE LED BOARD

1. Remove the PDP mask and PDP unit according to sections 4.4 and 4.5.
2. Unlatch the latch (A), then remove the LED board (B) from the latch (C).
3. To remove the LED board, disconnect the cable (D).

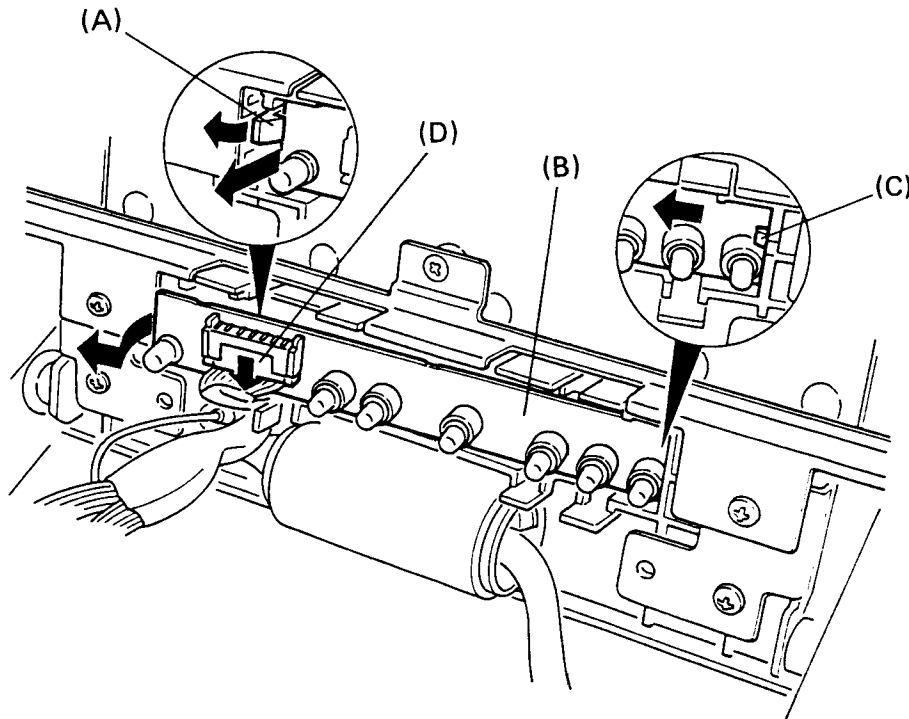

Figure 4-8 LED board

4. Reverse procedure to install.

4.7 REMOVING/REPLACING THE PDP COVER

1. Unplug the AC power cord from the system unit.
2. Turn the system unit upside down.
3. Remove the 5 screws (A).

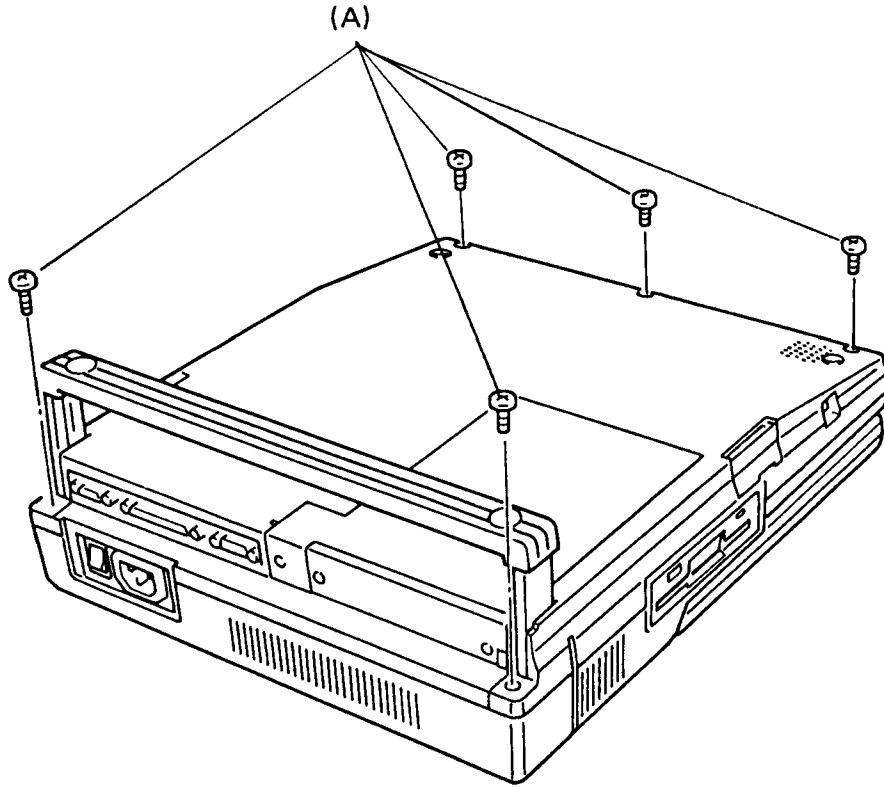

Figure 4-9 Base

4. Remove the keyboard, the PDP unit and the LED board according to sections 4.2 and 4.4 through 4.6.
5. Remove 3 screws (B) in the figure 4-13 according to section 4.8. Lift up PDP cover and top cover together and press the cable guide (B) nail out from the other side.
6. Remove the stopper plate (C) by removing 2 screws (D) and flat head screw (E).

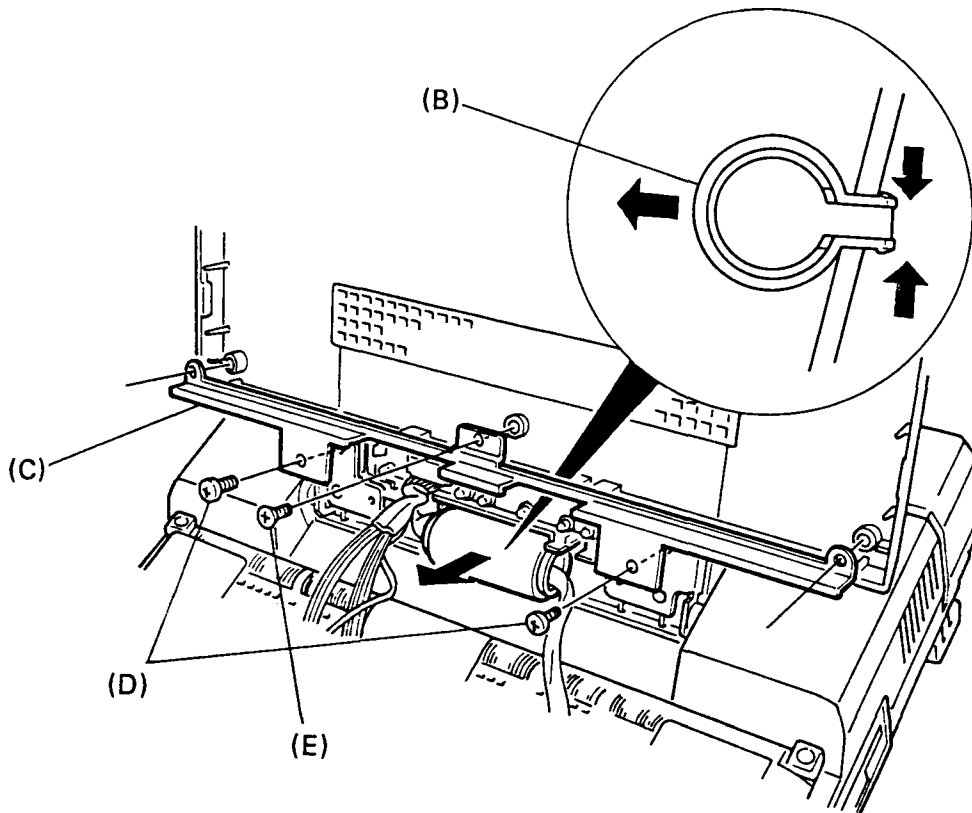

Figure 4-10 Stopper plate and cable guide

7. Remove 2 screws (G) from 2 hinges (F), and remove the ground wire (H) by removing a screw (I).
8. Remove the PDP cover (J) by shift 2 hinges to inside, then turn the PDP cover down and lift it up.

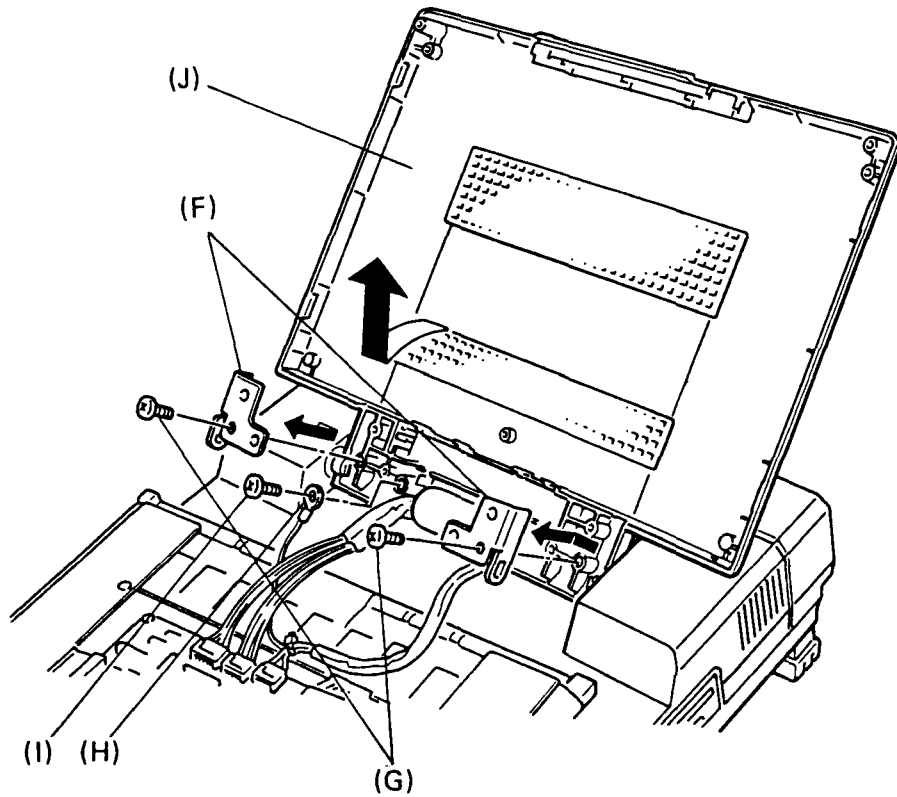

Figure 4-11 PDP cover and hinges

9. Reverse procedure to install.

NOTE: When you pass the cables through the cable guide, be careful as follows:

- (1) Put the plasma display power cable (K) to your right, and the LED board cable (L) and plasma display signal cable (M) to your left as shown in figure 4-12.
- (2) Put the cable guide in the top cover, then place each cable in the two ditches (N) of the PDP cover assembly as shown in figure 4-12.

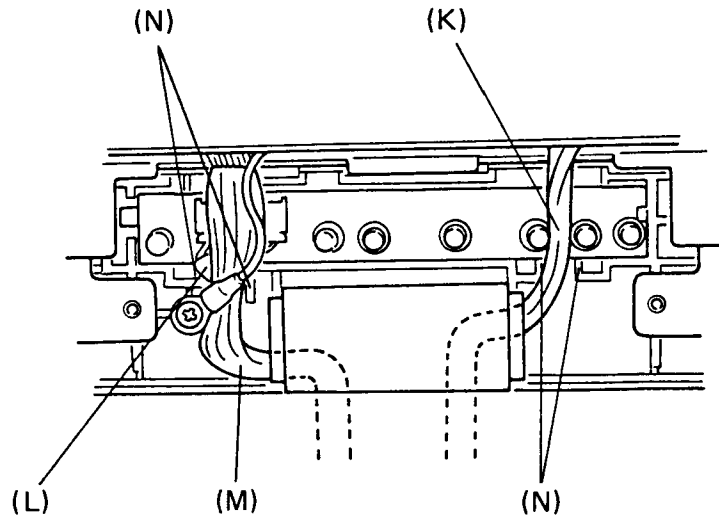

Figure 4-12 Cable position

4.8 REMOVING/REPLACING THE TOP COVER

1. Remove the keyboard, the PDP unit, the LED board and the PDP cover according to sections 4.2 and 4.5 through 4.7.
2. Remove the top cover (A) by removing 3 screws (B).

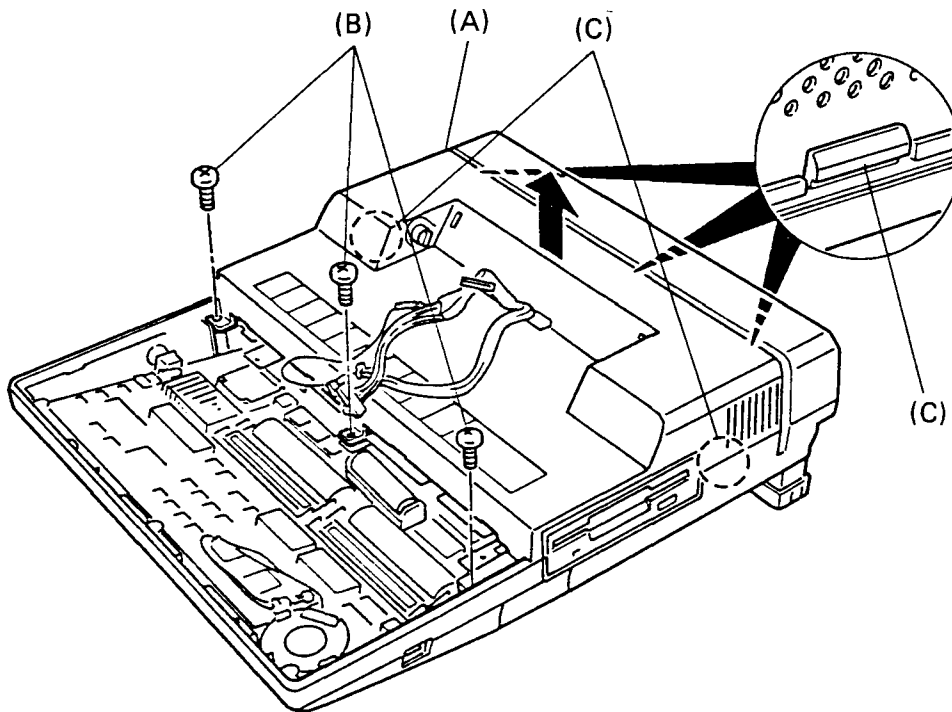

Figure 4-13 Top cover

4. Reverse procedure to install.

NOTE: Confirm that the top cover is locked into the base with 5 latches (C).

4.9 POWER SUPPLY UNIT

WARNING: Pay attention to handling the power supply unit to which high voltage is supplied. Note that it will take a few minutes to discharge the electricity after power-off.

1. Remove the keyboard, PDP mask, PDP unit, LED board and PDP cover with top cover according to sections 4.2 and 4.4 through 4.8.
2. Disconnect a connector (A) from the power supply board (PJ4).
3. Remove the power supply unit (B) by removing 5 screws (C), lift up it, then disconnect the connector (D) from the system board (PJ7).

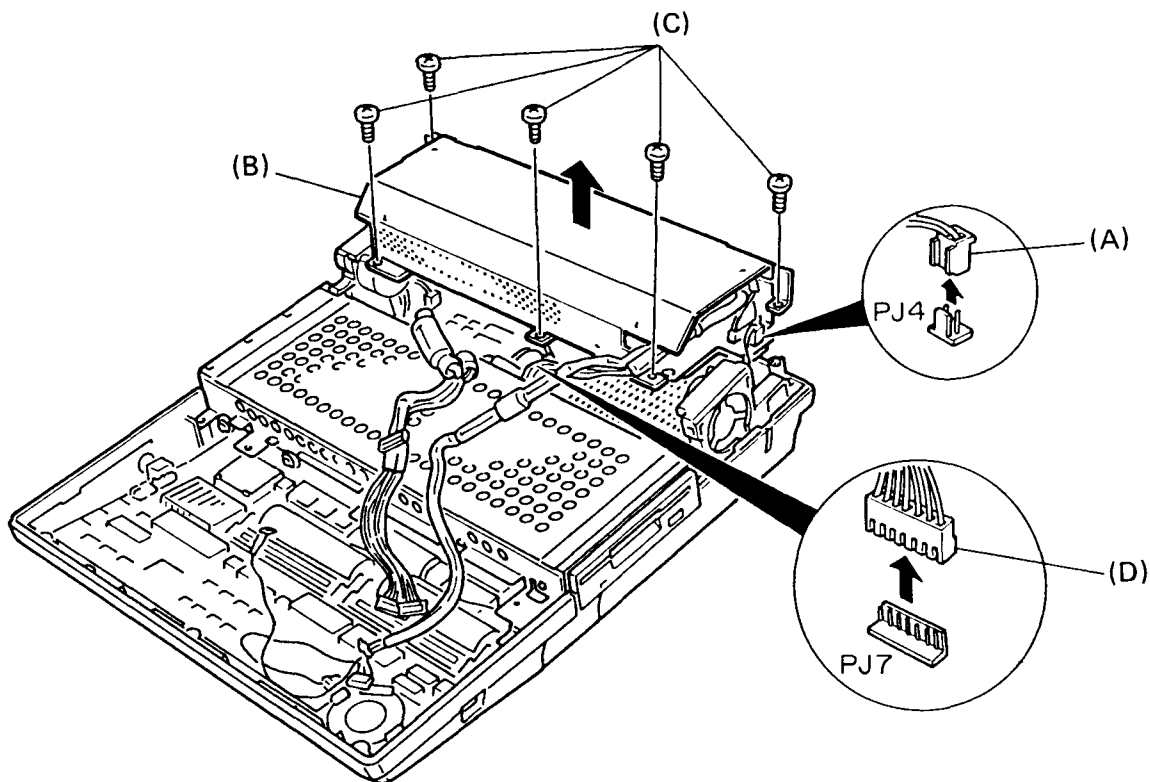

Figure 4-14 Power supply unit

4. Reverse procedure to install.

4.10 POWER SUPPLY COVER

1. Remove the keyboard, PDP mask PDP unit, LED board, PDP cover with top cover and power supply unit according to sections 4.2 and 4.4 through 4.9.
2. Remove the screw and washer assemblies (A) while lifting the power supply cover (B) slightly.
3. Remove the power supply cover by disengaging from 3 tabs (C) on the power supply base (D).

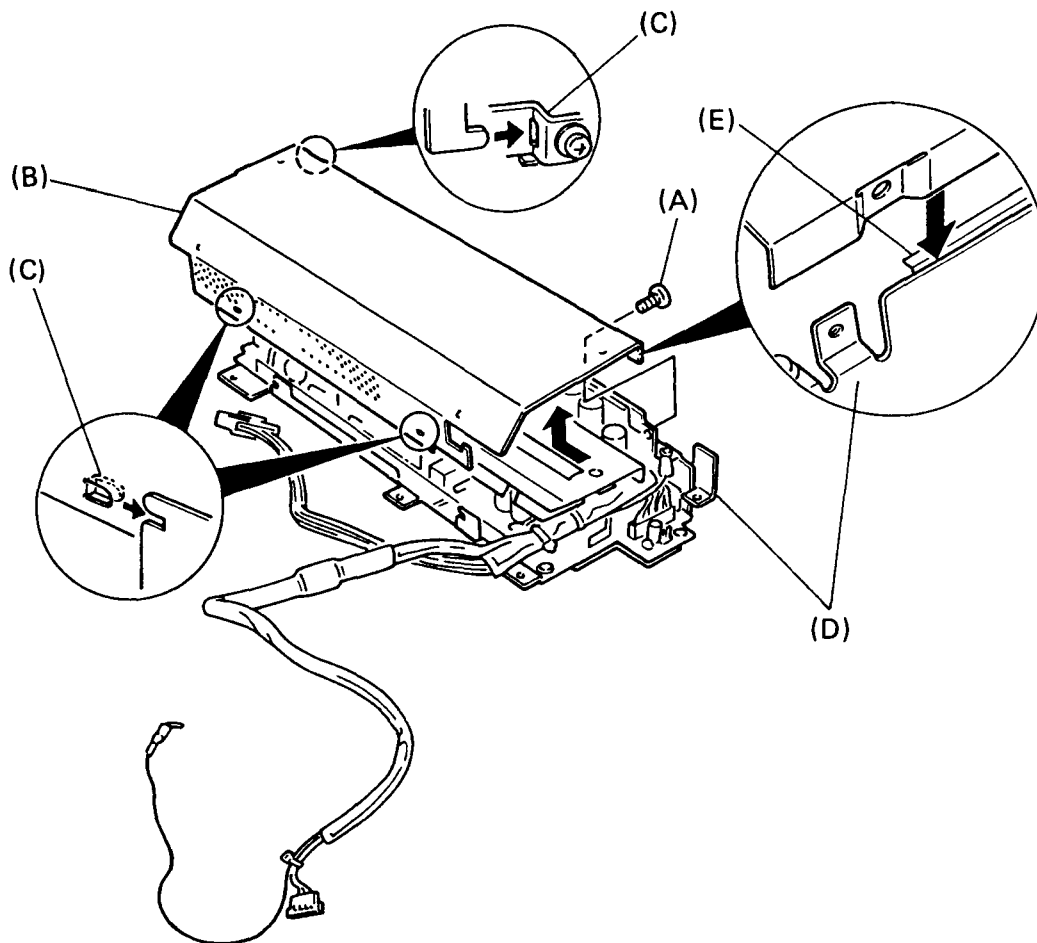

Figure 4-15 Power supply cover

4. Reverse procedure to install.

NOTE: In case of installing, place the power supply cover between the power supply base and the installing plate (E) and slide, then attach with screws after tabs enter.

4.11 DISK SUPPORT, PLASMA SENSOR AND LITHIUM BATTERY

1. Remove the keyboard, PDP mask, PDP unit, LED board, PDP cover with top cover and power supply unit according to sections 4.2 and 4.4, through 4.9.
2. Remove the disk support (A) by removing 2 screws (B).
3. Lift the disk support, then disconnect 4 connectors (C) from the system board (D).
4. Remove the plasma sensor (E) by removing flat head screw (F).
5. Disconnect the battery connector (G) from the system board, then remove the lithium battery (H) fixed on the system board with a snap-on fastener.

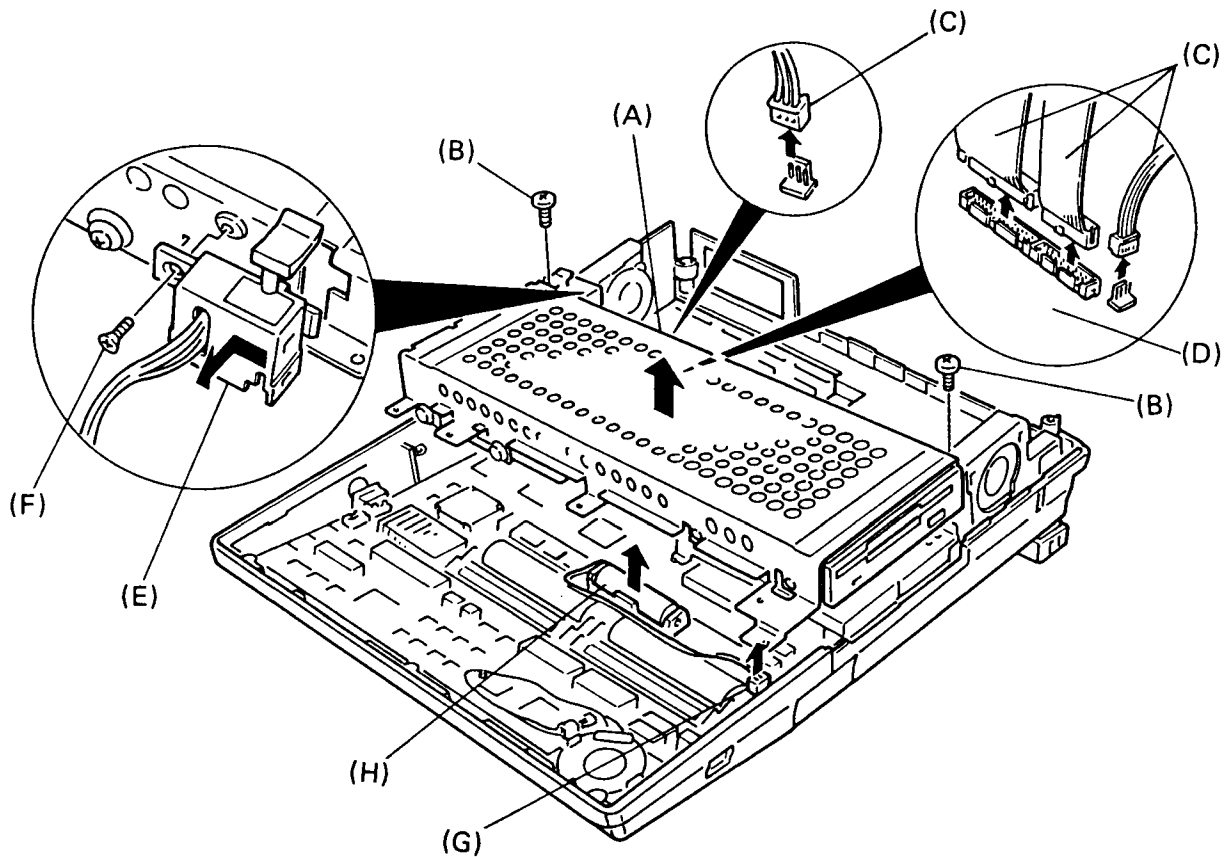

Figure 4-16 Disk support, plasma sensor and lithium battery

6. Reverse procedure to install.

4.12 FDD

1. Remove the keyboard, PDP mask, PDP unit, LED board, PDP cover with top cover, power supply unit and disk support according to sections 4.2, 4.4 through 4.9 and 4.11.
2. Remove FDD (A) by removing 2 screws (B) and 2 special screws (C) from the disk support (D).

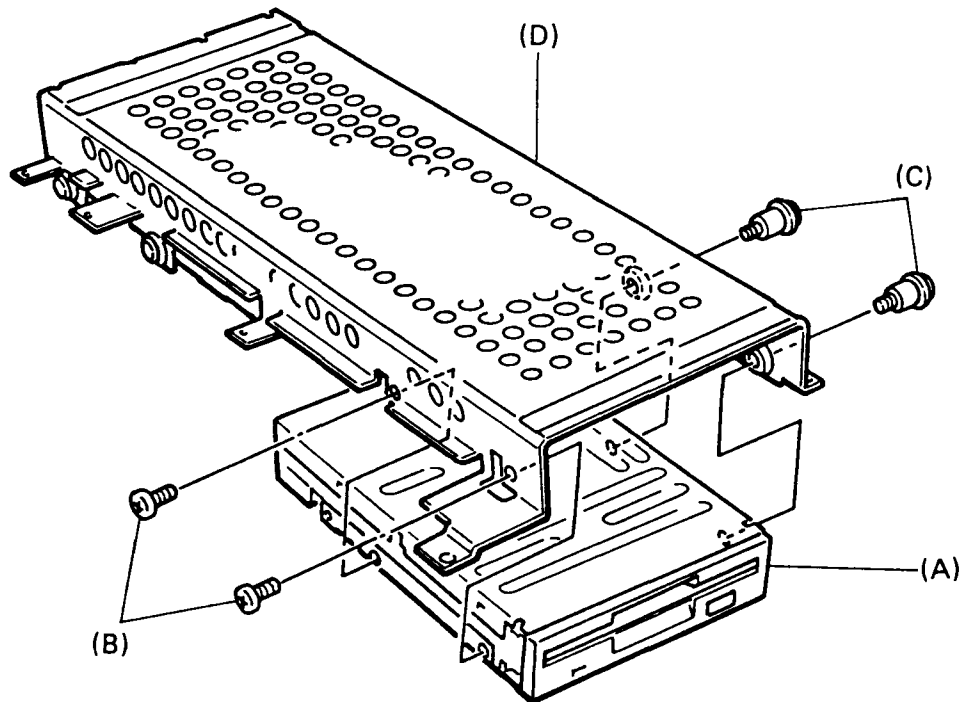

Figure 4-17 FDD

3. Reverse procedure to install

4.13 HDD

1. Remove the keyboard, PDP mask, PDP unit, LED board, PDP cover unit with top cover, power supply unit and disk support according to sections 4.2, 4.4 through 4.9, and 4.11.
2. Remove the HDD (A) by removing 4 special screws (B) from the disk support (C).

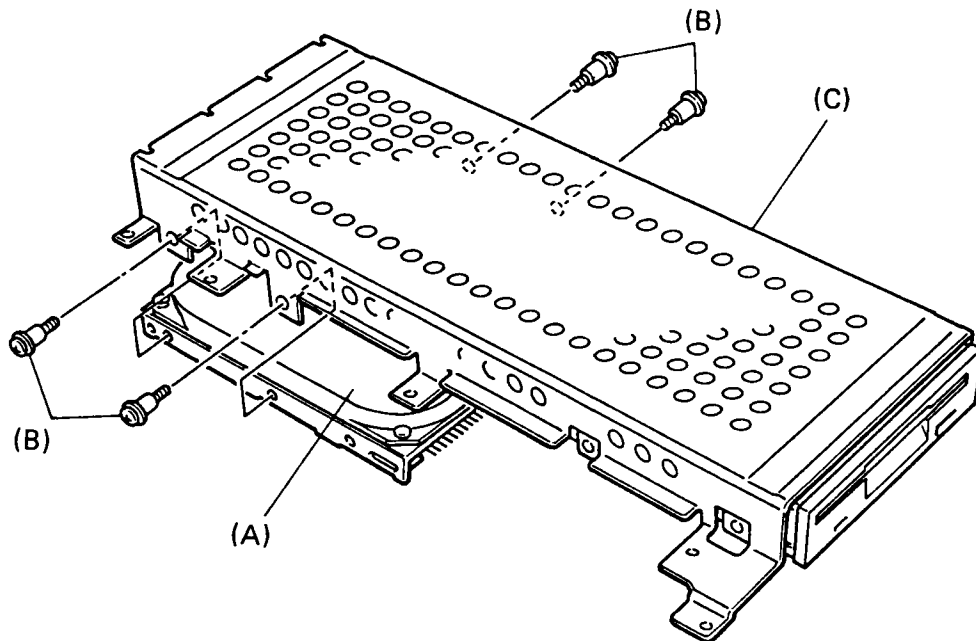

Figure 4-18 HDD

3. Reverse procedure to install.

4.14 COOLING FANS

1. Remove the keyboard, PDP mask, PDP unit, LED board, PDP cover with top cover, power supply unit and disk support according to sections 4.2, 4.4 through 4.7, 4.9 and 4.11.
2. Remove the right cooling fan (A) by lifting the cooling fan stopper (B) after unlatching the latches (C).
3. Disconnect the connector (D) from the system board (PJ14), then remove the left cooling fan (F) by lifting the cooling fan stopper after unlatching the latches.

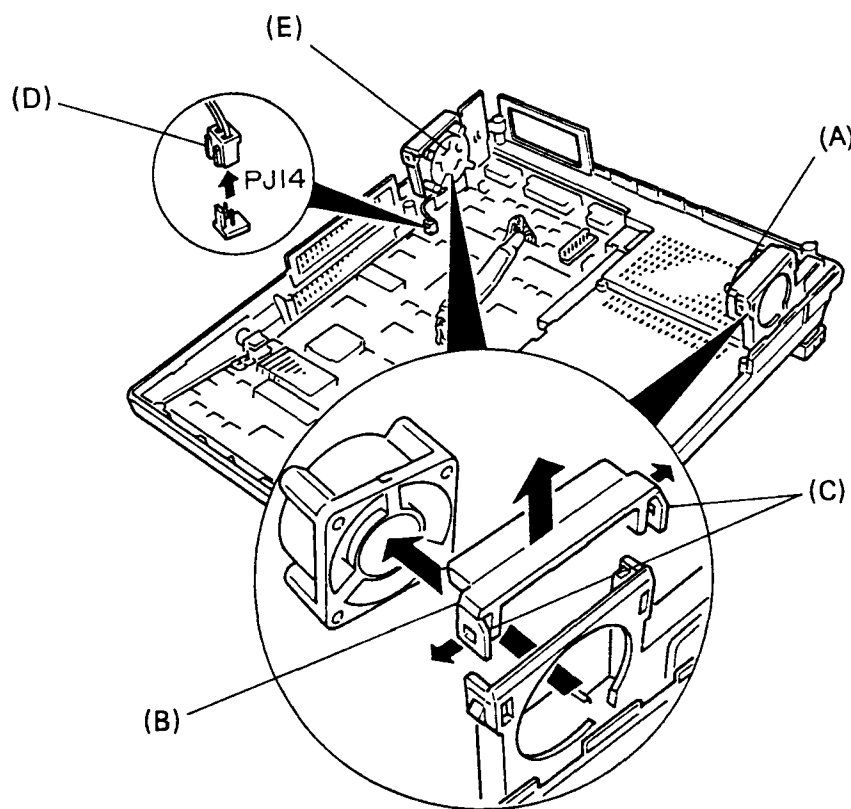

Figure 4-19 Cooling fans

4. Reverse procedure to install.

4.15 COOLING FAN HOLDER AND HANDLE

1. Remove the keyboard, PDP mask, PDP unit, LED board, PDP cover with top cover, power supply unit, disk support and cooling fans according to sections 4.2, 4.4 through 4.9, 4.11 and 4.14.
2. Remove the left and right cooling fan holder (A) by lifting them after removing 2 screws (B).
3. Remove the handle (C) by shifting toward the front and pull out after removing the cooling fan holders.

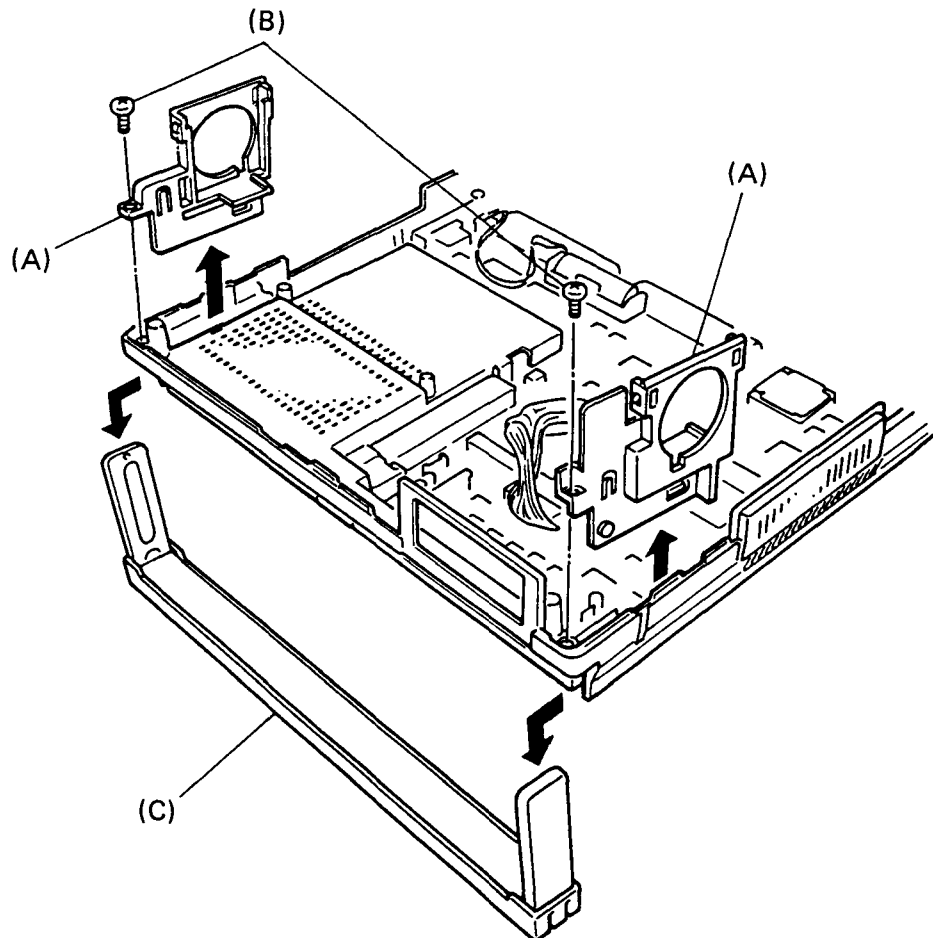

Figure 4-20 Cooling fan holder and handle

4 Reverse procedure to install

4.16 SYSTEM BOARD

CAUTION: Remove the T3100 support board if any.

1. Remove the keyboard, PDP mask, PDP unit, LED board, PDP cover with top cover, power supply unit, disk support, cooling fans and holders according to sections 4.2, 4.4 through 4.9, 4.11, 4.14 and 4.15.
2. Remove the system board (A) by removing 11 screws (B).

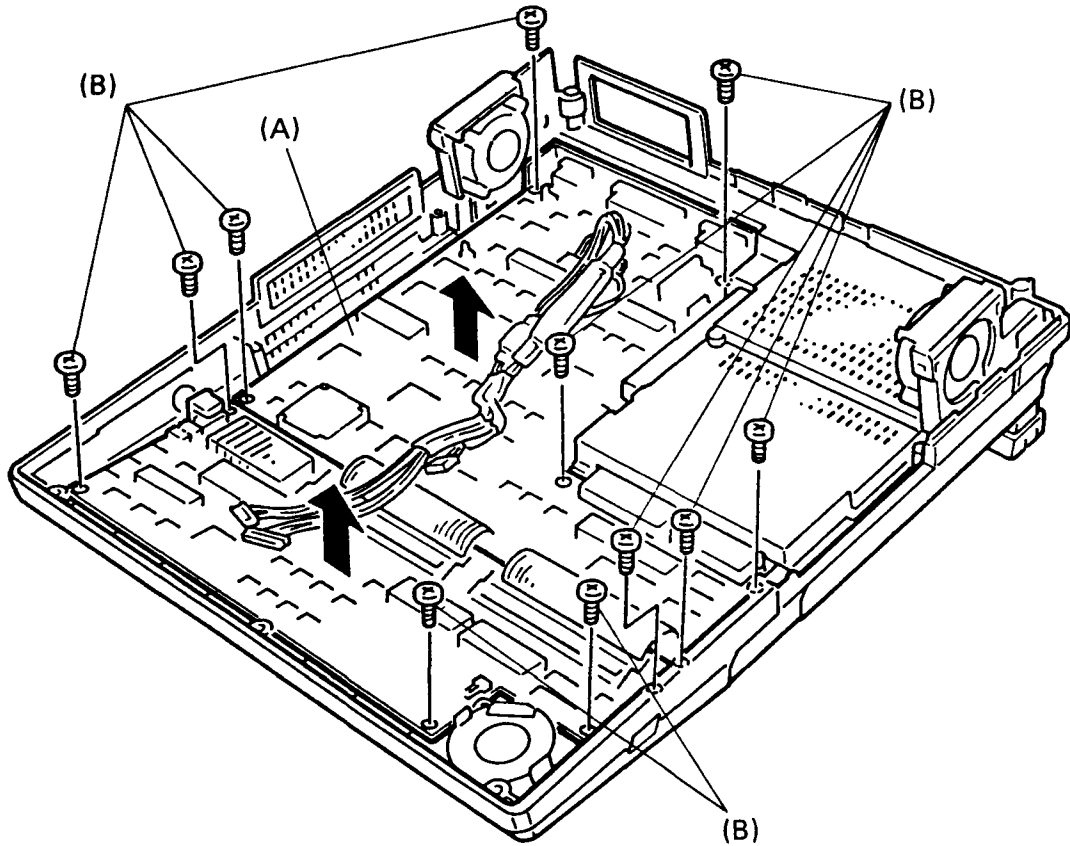
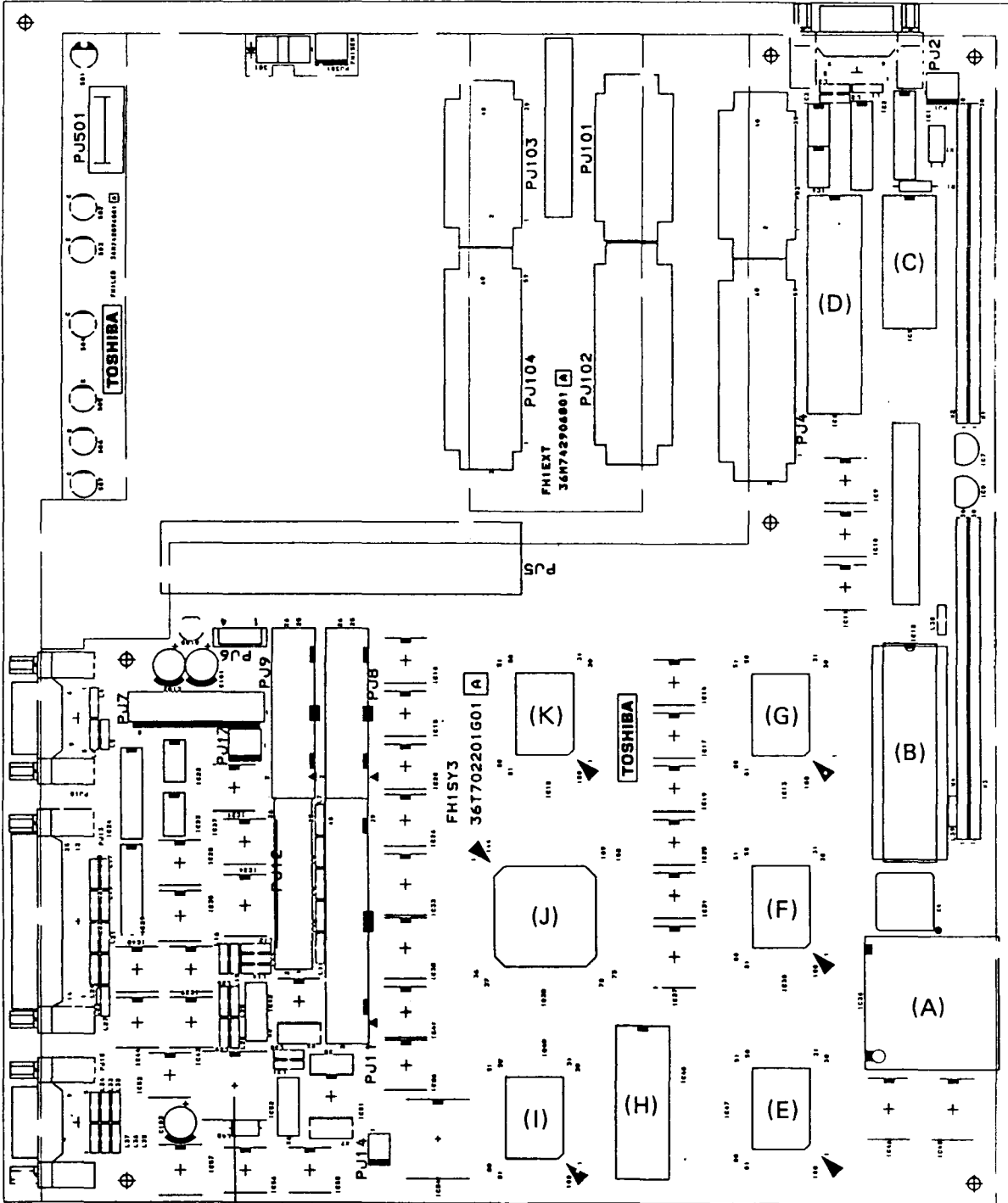

Figure 4-21 System board

3. Reverse procedure to install.

APPENDIX A BOARD LAYOUT

1. SYSTEM BOARD (ICS)



(L)
Figure A-1 System board (ICs)

(A)	CPU:	Central processing unit (80286-12)
(B)	NDP Socket:	Numeric data processing socket (80287-12)
(C)	RTC:	Real time clock (MC146818)
(D)	SIO:	Serial input/output controller (NS16450)
(E)	GA-BUS:	Bus controller gate array
(F)	GA-DMA3:	DMA controller gate array
(G)	GA-MAP3:	MAP controller gate array
(H)	CG-ROM:	Character generator ROM
(I)	GA-PLC:	PLC controller gate array
(J)	SI:	Super integration (T9761)
(K)	SI:	Super integration (M5M82C800)
(L)	VFO:	Variable frequency oscillator (MB4108A)

2. SYSTEM BOARD (CONNECTORS)

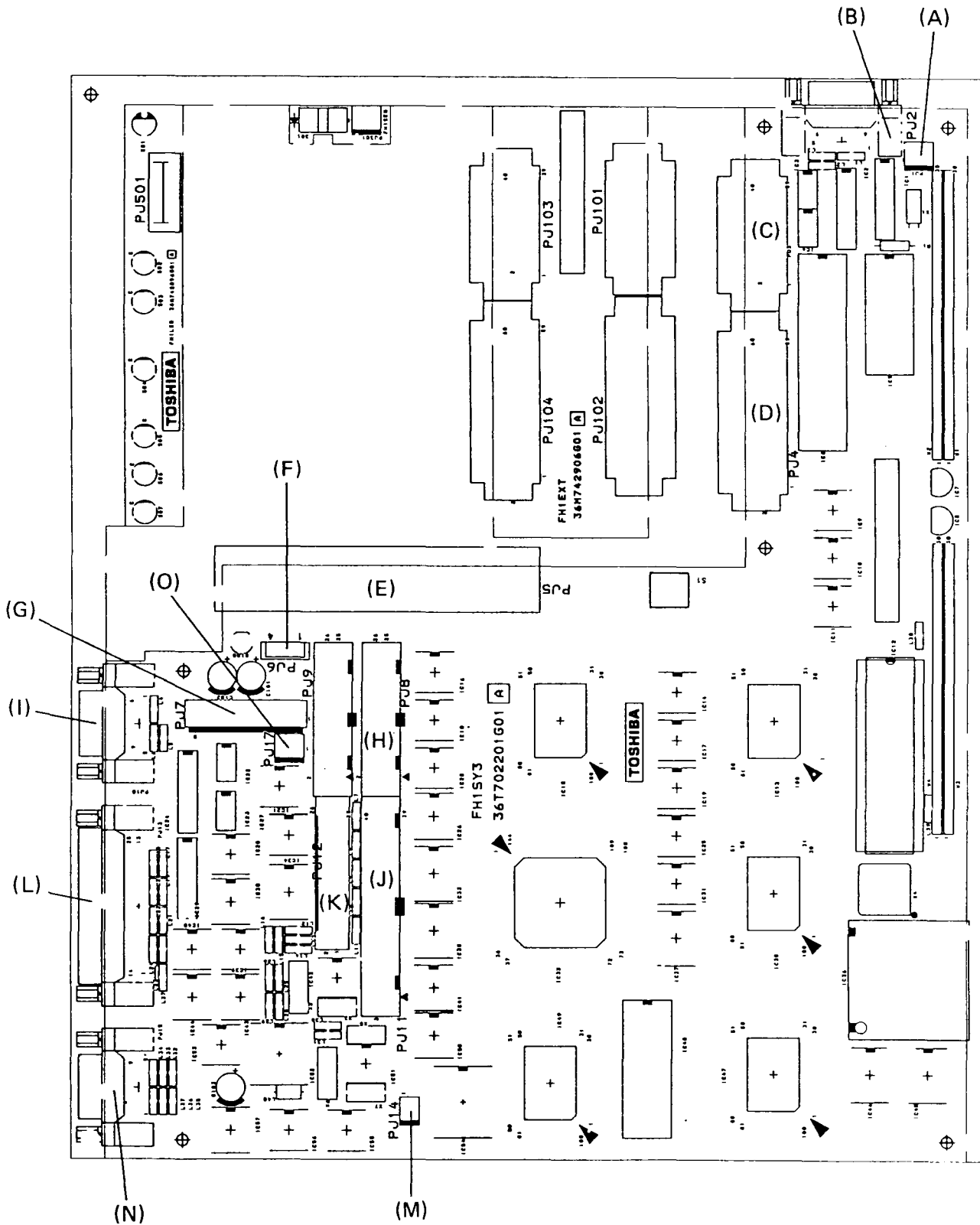

Figure A-2 System board (connectors)

- (A) PJ1: Lithium battery connector
- (B) PJ2: Serial B I/F connector
- (C) PJ3: Expansion bus connector (40 pin)
- (D) PJ4: Expansion bus connector (60 pin)
- (E) PJ5: 8-bit slot
- (F) PJ6: HDD power connector
- (G) PJ7: Power supply connector
- (H) PJ8: FDD connector
- (I) PJ10: Serial A I/F connector
- (J) PJ11: HDC I/F connector
- (K) PJ12: PDP/LED I/F connector
- (L) PJ13: PRT/FDD connector
- (M) PJ14: Cooling fan connector
- (N) PJ15: CRT I/F connector
- (O) PJ17: PDP sensor switch connector

- (A) Option memory I/F connector
- (B) System RAMs
- (C) KBC: Keyboard controller (8742 or 8042)
- (D) System BIOS ROMs
- (E) GA-EMS2: EMS controller gate array
- (F) PJ1: Selector connector
- (G) PJ2: Tenkey I/F connector
- (H) PJ3: Keyboard I/F connector
- (I) PJ6: Speaker connector
- (J) S1: A-B-PRT switch

**APPENDIX B
PIN ASSIGNMENT**

1. SYSTEM BOARD

1.1 PJ 1 Lithium Battery Connector

Table B-1 Lithium battery connector pin assignment

Pin	Signal	I/O	Pin	Signal	I/O
1	GND	I	2	N/C	
3	BAT36V;100	I			

1.2 PJ 2 Serial B I/F Connector

Table B-2 Serial B I/F connector pin assignment

Pin	Signal	I/O	Pin	Signal	I/O
1	MDCD2;100	I	2	MDRD2;100	I
3	MDTD2;110	O	4	MDDTR2;110	O
5	GND		6	MDDSR2;110	I
7	MDRTS2;110	O	8	MDCTS2;100	I
9	MDRIS;100	I			

1.3 PJ 3 Expansion Bus Connector (40 pin)

Table B-3 Expansion bus connector pin assignment (40 pin)

Pin	Signal	I/O	Pin	Signal	I/O
1	IRQ10;100	I	2	IRQ14;100	I
3	SD8;100	I/O	4	SD9;100	I/O
5	IRQ11;100	I	6	SD10;100	I/O
7	SD11;100	I/O	8	SD12;100	I/O
9	IRQ12;100	I	10	GND	
11	SD13;100	I/O	12	SD14;100	I/O
13	IRQ6;100	I	14	SD15;100	I/O
15	A22;100	I/O	16	A23;100	I/O
17	DRQ2;100	I	18	A21;100	I/O
19	A19;100	I/O	20	A20;100	I/O
21	DACK5;000	O	22	GND	
23	REFRSH;000	I/O	24	A18;100	I/O
25	MASTER;000	I	26	A17;100	I/O
27	SBHE;000	I/O	28	IOCHK;000	I
29	MEM16;000	I	30	GND	
31	IO16;000	I	32	DACK2;000	O
33	DRQ6;100	I	34	DRQ5;100	I
35	DACK5;000	O	36	MEMR;000	I/O
37	IRQ4;100	I	38	MEMW;000	I/O
39	IRQ7;100	I	40	GND	

1.4 PJ 4 Expansion Bus Connector (60 pin)

Table B-4 Expansion bus connector pin assignment (60 pin)

Pin	Signal	I/O	Pin	Signal	I/O
1	GND		2	VCC	O
3	M9V	O	4	P12V	O
5	CCMCS3;000	O	6	CCMCLK;000	O
7	TIRQ;000	I	8	MDSPK;000	I
9	GND		10	SA0;100	I/O
11	SA1;100	I/O	12	SA2;100	I/O
13	SA3;100	I/O	14	SA4;100	I/O
15	SA5;100	I/O	16	SA6;100	I/O
17	SA7;100	I/O	18	GND	
19	SA8;100	I/O	20	SA9;100	I/O
21	SA10;100	I/O	22	SA11;100	I/O
23	SA12;100	I/O	24	SA13;100	I/O
25	SA14;100	I/O	26	SA15;100	I/O
27	GND		28	SA16;100	I/O
29	SA17;100	I/O	30	SA18;100	I/O
31	SA19;100	I/O	32	SD0;100	I/O
33	SD1;100	I/O	34	SD2;100	I/O
35	SD3;100	I/O	36	GND	
37	SD4;100	I/O	38	SD5;100	I/O
39	SD6;100	I/O	40	SD7;100	I/O
41	SMEMW;000	O	42	SMEMR;000	O
43	GND		44	IOW;000	I/O
45	IOR;000	I/O	46	TC;100	O
47	BALE;100	O	48	RESET;101	O
49	DACK1;000	O	50	IRQ9;100	I
51	GND		52	VCC	O
53	SYSCLK;110	O	54	IRQ5;100	I
55	DRQ3;100	I	56	DACK3;000	O
57	DMACK;110	O	58	DRQ1;100	I
59	IORDY;100	I	60	GND	

1.5 PJ 5A 8-bit Slot

Table B-5 8-bit slot pin assignment

Pin	Signal	I/O	Pin	Signal	I/O
1	IOCHK;000	I	2	SD7;100	I/O
3	SD6;100	I/O	4	SD5;100	I/O
5	SD4;100	I/O	6	SD3;100	I/O
7	SD2;100	I/O	8	SD1;100	I/O
9	SD0;100	I/O	10	IORDY;100	I/O
11	DMACK;110	O	12	SA19;100	I/O
13	SA18;100	I/O	14	SA17;100	I/O
15	SA16;100	I/O	16	SA15;100	I/O
17	SA14;100	I/O	18	SA13;100	I/O
19	SA12;100	I/O	20	SA11;100	I/O
21	SA10;100	I/O	22	SA9;100	I/O
23	SA8;100	I/O	24	SA7;100	I/O
25	SA6;100	I/O	26	SA5;100	I/O
27	SA4;100	I/O	28	SA3;100	I/O
29	SA2;100	I/O	30	SA1;100	I/O
31	SA0;100	I/O			

1.6 PJ 5B 8-bit Slot

Table B-6 8-bit slot pin assignment

Pin	Signal	I/O	Pin	Signal	I/O
1	GND		2	RESET;101	O
3	VCC		4	IRQ9;100	I
5	M5V		6	DRQ2;100	I
7	M12V		8	OWAIT;000	I
9	P12V		10	GND	
11	SMEMW;000	O	12	SMEMR;000	O
13	IOW;000	I/O	14	IOR;000	I/O
15	DACK3;000	O	16	DRQ3;100	I
17	DACK1;000	O	18	DRQ1;100	I
19	REERSH;000	I/O	20	SYSCLK;110	O
21	IRQ7;100	I	22	IRQ6;100	I
23	IRQ5;100	I	24	IRQ4;100	I
25	MIRQ3;100	I	26	DACK2;000	O
27	TC;100	O	28	BALE;100	O
29	VCC	O	30	CLKCRT;100	O
31	GND				

1.7 PJ 6 HDD Power Connector

Table B-7 HDD power connector pin assignment

Pin	Signal	I/O	Pin	Signal	I/O
1	P12V	0	2	GND	
3	GND		4	P5V	0

1.8 PJ 7 Power Supply Connector

Table B-8 Power supply connector pin assignment

Pin	Signal	I/O	Pin	Signal	I/O
1	P12V	I	2	GND	
3	M12V	I	4	M5V	I
5	GND		6	GND	
7	VCC	I	8	VCC	I

1.9 PJ 8 FDD Connector

TABLE B-9 FDD Connector Pin Assignment

PIN	SIGNAL	I/O	PIN	SIGNAL	I/O
1	VCC	0	2	INDEX;000	I
3	VCC	0	4	FDSELA;000	0
5	VCC	0	6	DSKCHG;000	I
7	VCC	0	8	READY;000	I
9	NOTCH0;000	I	10	MONA;000	0
11	LOWDNS;000	0	12	FDCDCR;000	0
13	GND		14	STEP;000	0
15	GND		16	WDATA;000	0
17	GND		18	WGATE;000	0
19	GND		20	TRACK0;000	I
21	GND		22	WPROTC;000	I
23	GND		24	RDDA;000	I
25	GND		26	SIDE;000	0

1.10 PJ 10 Serial A I/F Connector

Table B-10 Serial A I/F connector

Pin	Signal	I/O	Pin	Signal	I/O
1	MDCD1;100	I	2	MDRD1;100	I
3	MDTD1;110	0	4	MDDTR1;110	0
5	GND		6	MDDSR1;110	I
7	MDRTS1;110	0	8	MDCTS1;100	I
9	MDRI1;100	I			

1.11 PJ 11 HDC I/F Connector

Table B-11 HDC I/F connector

Pin	Signal	I/O	Pin	Signal	I/O
1	HRESET;001	0	2	GND	
3	HSD7;100	I/O	4	HSD8;100	I/O
5	HSD6;100	I/O	6	HSD9;100	I/O
7	HSD5;100	I/O	8	HSD10;100	I/O
9	HSD4;100	I/O	10	HSD11;100	I/O
11	HSD3;100	I/O	12	HSD12;100	I/O
13	HSD2;100	I/O	14	HSD13;100	I/O
15	HSD1;100	I/O	16	HSD14;100	I/O
17	HSD0;100	I/O	18	HSD15;100	I/O
19	GND		20	N/C	
21	N/C		22	GND	
23	HIOW;001	0	24	GND	
25	HIOR;001		26	GND	
27	N/C		28	N/C	
29	N/C		30	GND	
31	IRQ14;100	I	32	HIO16;000	I
33	HSA1;101	0	34	N/C	
35	HSA0;101	0	36	HSA2;101	0
37	HDDCS0;010	0	38	HDDCS1;000	0
39	HDDLED;000	I	40	GND	

1.12 PJ 12 PDP/LED I/F Connector

Table B-12 PDP/LED I/F connector

Pin	Signal	I/O	Pin	Signal	I/O
1	PVSYKC;110	O	2	GND	
3	PHSYNC;110	O	4	GND	
5	PDP1;110	O	6	PDP2;110	O
7	PDP3;110	O	8	PDP4;110	O
9	GND		10	GND	
11	PSCK;110	O	12	GND	
13	VCC		14	VCC	
15	PENA;100	O	16	N/C	
17	N/C		18	GND	
19	DRVALD;000		20	DRVBLD;000	O
21	CRTLED;000	O	22	VCC	
23	SEF6M;020		24	LED CAP;020	O
25	LEDNUM;020	O	26	LEDSCR;020	O

1.13 PJ 13 PRT/FDD Connector

Table B-13 PRT/FDD connector pin assignment

Pin	(For PRT)		(For EXT FDD)	
	Signal	I/O	Signal	I/O
1	STROBE;000	O	READY;100	I
2	PD0;110	O	INDEX;000	I
3	PD1;110	O	TRACK0;000	I
4	PD2;110	O	WPROTC;000	I
5	PD3;110	O	RDDA;000	I
6	PD4;110	O	DSKCHG;000	I
7	PD5;110	O	-	
8	PD6;110	O	-	
9	PD7;110	O	-	
10	ACK;000	I	SWFDB;000	O
11	BUSY;100	I	SWMONB;000	O
12	PE;100	I	WRDATA;000	O
13	SELECT;100	I	EXFDWE;000	O
14	AUTFD;000	O	XRATE0;000	O
15	ERROR;000	I	SIDE;000	O
16	PINIT;000	O	FDCDRC;000	O
17	SLIN;000	O	STEP;000	O
18	GND		GND	
25				

1.14 PJ 14 Cooling Fan Connector

Table B-14 Cooling fan connector pin assignment

Pin	Signal	I/O	Pin	Signal	I/O
1	P12V	O	2	GND	

1.15 PJ 15 CRT I/F Connector

Table B-15 CRT I/F connector pin assignment

Pin	Signal	I/O	Pin	Signal	I/O
1	GND		2	GND	
3	DRPD1;111	O	4	DGPD2;111	O
5	DBPD3;111	O	6	DIPD4;111	O
7	N/C		8	DHSYNC;111	O
9	DVXYNC;111	O			

1.16 PJ 17 PDP sensor switch connector

Table B-16 PDP sensor switch connector

Pin	Signal	I/O	Pin	Signal	I/O
1	GND		2	VCC	O
3	PDPON;100	I			

2. MEMORY BOARD

2.1 IS 101A Option Memory I/F Connector

Table B-17 Option memory I/F connector pin assignment

Pin	Signal	I/O	Pin	Signal	I/O
1	VCC	O	2	CASH;000	O
3	MDB;100	I/O	4	MA0;100	O
5	MA1;100	O	6	MD9;100	I/O
7	MA2;100	O	8	MA3;100	O
9	GND		10	MA10;100	I/O
11	MA4;100	O	12	MA5;100	O
13	MD11;100	I/O	14	MA6;100	O
15	MA7;100	O	16	MD12;100	I/O
17	MA8;100	O	18	MA9;100	O
19	GND		20	MD13;100	I/O
21	MEMWE;000	O	22	GND	
23	MD14;100	I/O	24	ASL256;000	I
25	MD15;100	I/O	26	PDOH;100	I
27	RASA;000	O	28	ASL1M;000	I
29	PDINH;100	O	30	VCC	O

2.2 IS 101B Option Memory I/F Connector

Table B-18 Option memory I/F connector pin assignment

Pin	Signal	I/O	Pin	Signal	I/O
1	VCC	O	2	CASL;100	O
3	MD0;100	I/O	4	MA0;100	O
5	MA1;100	O	6	MD1;100	I/O
7	MA2;100	O	8	MA3;100	O
9	GND		10	MA2;100	I/O
11	MA4;100	O	12	MA5;100	O
13	MD3;100	I/O	14	MA6;100	O
15	MA7;100	O	16	MD4;100	I/O
17	MA8;100	O	18	MA9;100	O
19	GND		20	MD5;100	I/O
21	MEMWE;000	O	22	GND	
23	MD6;100	I/O	24	ASL256;000	I
25	MD7;100	I/O	26	PDOL;100	I
27	RASA;000	O	28	ASL1M;000	I
29	PDINL;100	O	30	VCC	O

2.3 IS 102A Option Memory I/F Connector

Table B-19 Option memory I/F connector pin assignment

Pin	Signal	I/O	Pin	Signal	I/O
1	VCC	O	2	CASH;000	O
3	MDB;100	I/O	4	MA0;102	O
5	MA1;102	O	6	MD9;100	I/O
7	MA2;102	O	8	MA3;102	O
9	GND		10	MD10;100	I/O
11	MA4;102	O	12	MA5;102	O
13	MD11;100	I/O	14	MA6;102	O
15	MA7;102	O	16	MD12;100	I/O
17	MA8;102	O	18	MA9;102	O
19	GND		20	MD13;100	I/O
21	MEMWE;000	O	22	GND	
23	MD14;100	I/O	24	BSL256;000	I
25	MD15;100	I/O	26	PDOH;100	I
27	RASB;000	O	28	BSL1M;000	I
29	PDINH;100	O	30	VCC	O

2.4 IS 102B Option Memory I/F Connector

Table B-20 Option memory I/F connector pin assignment

Pin	Signal	I/O	Pin	Signal	I/O
1	VCC	O	2	CASL;000	O
3	MD0;100	I/O	4	MA0;102	O
5	MA1;102	O	6	MD1;100	I/O
7	MA2;102	O	8	MA3;102	O
9	GND		10	MA2;100	I/O
11	MA4;102	O	12	MA5;102	O
13	MD3;100	I/O	14	MA6;102	O
15	MA7;102	O	16	MD4;100	I/O
17	MA8;102	O	18	MA9;102	O
19	GND		20	MD5;100	I/O
21	MEMWE;000	O	22	GND	
23	MD6;100	I/O	24	BSL256;000	I
25	MD7;100	I/O	26	PDOL;100	I
27	RASB;000	O	28	BSL1M;000	I
29	PDINL;100	O	30	VCC	O

2.5 PJ 1 Selector Connector

Table B-21 Selector connector pin assignment

Pin	Signal	I/O	Pin	Signal	I/O
1	GND		2	FD2;000	I
3	VCC	O	4	FD2MB;000	I
5	VCC	O	6	F2HD;000	I

2.6 PJ 2 Tenkey I/F Connector

Table B-22 Tenkey I/F connector pin assignment

Pin	Signal	I/O	Pin	Signal	I/O
1	KBSC14;000	O	2	KBSC13;000	O
3	KBSC12;000	O	4	KBSC11;000	O
5	KBRT3;000	I	6	KBRT2;000	I
7	KBRT1;000	I	8	KBRT0;000	I

2.7 PJ 3 Keyboard Connector

Table B-23 Keyboard connector pin assignment

Pin	Signal	I/O	Pin	Signal	I/O
1	KBSC0;000	O	2	KBSC1;000	O
3	KBSC2;000	O	4	GND	
5	KBSC3;000	O	6	KBSC4;000	O
7	KBSC5;000	O	8	KBSC6;000	O
9	GND		10	KBSC7;000	O
11	KBSC8;000	O	12	KBSC9;000	O
13	KBSC10;000	O	14	KBRTN0;000	I
15	KBRTN1;000	I	16	KBRTN2;000	I
17	KBRTN3;000	I	18	GND	
19	KBRTN4;000	I	20	KBRTN5;000	I
21	KBRTN6;000	I	22	KBRTN7;000	I

2.8 PJ 6 Speaker Connector

Table B-24 Speaker connector pin assignment

Pin	Signal	I/O	Pin	Signal	I/O
1	SPKON;100	O	2	SPVCC;100	O

3. LED BOARD

3.1 PJ 501 FH1LED Connector

Table B-25 FH1LED connector pin assignment

Pin	Signal	I/O	Pin	Signal	I/O
1	GND		2	DRVALD;000	I
3	DRVBLD;000	I	4	CRTLED;000	I
5	VCC	I	6	SEL6M;010	I
7	LEDCAP;000	I	8	LEDNUM;000	I
9	LEDSCR;000	I			

4. T3100 SUPPORT BOARD

4.1 PJ 101 System I/F Connector (40 pin)

Table B-26 System I/F connector pin assignment (40 pin)

Pin	Signal	I/O	Pin	Signal	I/O
1	IRQ10;101	O	2	IRQ14;101	O
3	SD8;101	I/O	4	SD9;101	I/O
5	IRQ11;101	O	6	SD10;101	I/O
7	SD11;101	I/O	8	SD12;101	I/O
9	IRQ12;101	O	10	GND	
11	SD13;101	I/O	12	SD14;101	I/O
13	IRQ6;101	O	14	SD15;101	I/O
15	A22;101	I/O	16	A23;101	I/O
17	DRQ2;101	O	18	A21;101	I/O
19	A19;101	I/O	20	A20;101	I/O
21	DACK6;001	I	22	GND	
23	REFRSH;001	I/O	24	A18;101	I/O
25	MASTER;001	O	26	A17;101	I/O
27	SBHE;001	I/O	28	IOCHK;001	O
29	MEM16;001	O	30	GND	
31	IO16;001	O	32	DACK2;001	I
33	DRQ6;101	O	34	DRQ5;101	O
35	DACK5;001	I	36	MEMR;001	I/O
37	IRQ4;101	O	38	MEMW;001	I/O
39	IRQ7;101	O	40	GND	

I: System board -----> T3100 support board
O: T3100 support board -----> System board

4.2 PJ 102 System I/F Connector (60 pin)

Table B-27 System I/F connector pin assignment (60 pin)

Pin	Signal	I/O	Pin	Signal	I/O
1	GND		2	VCC	
3	ESM9V		4	EXP12V	
5	CCMCS3;001	I	6	CCMCLK;101	I
7	TIRQ;001	O	8	MDSPK;001	O
9	GND		10	SA0;101	I/O
11	SA1;101	I/O	12	SA2;101	I/O
13	SA3;101	I/O	14	SA4;101	I/O
15	SA5;101	I/O	16	SA6;101	I/O
17	SA7;101	I/O	18	GND	
19	SA8;101	I/O	20	SA9;101	I/O
21	SA10;101	I/O	22	SA11;101	I/O
23	SA12;101	I/O	24	SA13;101	I/O
25	SA14;101	I/O	26	SA15;101	I/O
27	GND		28	SA16;101	I/O
29	SA17;101	I/O	30	SA18;101	I/O
31	SA19;101	I/O	32	SD0;101	I/O
33	SD1;101	I/O	34	SD2;101	I/O
35	SD3;101	I/O	36	GND	
37	SD4;101	I/O	38	SD5;101	I/O
39	SD6;101	I/O	40	SD7;101	I/O
41	SMEMW;001	I	42	SMEMR;001	I
43	GND		44	IOW;010	I/O
45	IOR;001	I/O	46	TC;101	I
47	BALE;101	I	48	RESET;102	I
49	DACK1;001	I	50	IRQ9;101	O
51	GND		52	VCC	
53	SYSCLK;111	I	54	IRQ5;101	O
55	DRQ;101	O	56	DACK3;101	I
57	DMACK;111	I	58	DRQ1;101	O
59	IORDY;101	O	60	GND	

I: System board ----> T3100 support board

O: T3100 support board ----> System board

4.3 PJ 103 Toshiba Slot (40 pin)

Table B-28 Toshiba slot pin assignment (40 pin)

Pin	Signal	I/O	Pin	Signal	I/O
1	IRQ10;101	I	2	IRQ14;101	I
3	SD8;101	I/O	4	SD9;101	I/O
5	IRQ11;101	I	6	SD10;101	I/O
7	SD11;101	I/O	8	SD12;101	I/O
9	IRQ12;101	I	10	GND	
11	SD13;101	I/O	12	SD14;101	I/O
13	IRQ6;101	I	14	SD15;101	I/O
15	A22;101	I/O	16	A23;101	I/O
17	DRQ2;101	I	18	A21;101	I/O
19	A19;101	I/O	20	A20;101	I/O
21	DACK6;001	O	22	GND	
23	REFRSH;001	I/O	24	A18;101	I/O
25	MASTER;001	I	26	A17;101	I/O
27	SBHE;001	I/O	28	IOCHK;001	I
29	MEM16;001	I	30	GND	
31	IO16;001	I	32	DACK2;001	O
33	DRQ6;101	I	34	DRQ5;101	I
35	DACK5;001	O	36	MEMR;001	I/O
37	IRQ4;101	I	38	MEMW;001	I/O
39	IRQ7;101	I	40	GND	

I: Option card ----> T3100 support board

O: T3100 support board ----> Option card

4.4 PJ 104 Toshiba Slot (60 pin)

Table B-29 Toshiba slot pin assignment (60 pin)

Pin	Signal	I/O	Pin	Signal	I/O
1	GND		2	VCC	
3	EXM9V		4	EXP12V	
5	CCMCS3;001	O	6	CCMCLK;101	O
7	TIRQ;001	I	8	MDSPK;001	I
9	GND		10	SA0;101	I/O
11	SA1;101	I/O	12	SA2;101	I/O
13	SA3;101	I/O	14	SA4;101	I/O
15	SA5;101	I/O	16	SA6;101	I/O
17	SA7;101	I/O	18	GND	
19	SA8;101	I/O	20	SA9;101	I/O
21	SA10;101	I/O	22	SA11;101	I/O
23	SA12;101	I/O	24	SA13;101	I/O
25	SA14;101	I/O	26	SA15;101	I/O
27	GND		28	SA16;101	I/O
29	SA17;101	I/O	30	SA18;101	I/O
31	SA19;101	I/O	32	SD0;101	I/O
33	SD1;101	I/O	34	SD2;101	I/O
35	SD3;101	I/O	36	GND	
37	SD4;101	I/O	38	SD5;101	I/O
39	SD6;101	I/O	40	SD7;101	I/O
41	SMEMW;001	O	42	SMEMR;001	O
43	GND		44	IOW;010	I/O
45	IOR;001	I/O	46	TC;101	O
47	BALE;101	O	48	RESET;102	O
49	DACK1;001	O	50	IRQ9;101	I
51	GND		52	VCC	
53	SYSCLK;111	O	54	IRQ5;101	I
55	DRQ;101	I	56	DACK3;001	O
57	DMACK;111	O	58	DRQ1;101	I
59	IORDY;101	I	60	GND	

I: Option card ----> T3100 support board

O: T3100 support board ----> Option card

**APPENDIX C
DISPLAY CODE**

Table C-1 Display code

HEXA DECIMAL VALUE	0	1	2	3	4	5	6	7	8	9	A	B	C	D	E	F
0	BLANK (NULL)	▶	BLANK (SPACE)	0	@	P	'	p	Ç	É	á	⋮	⌈	⌋	α	≡
1	☺	◀	!	1	A	Q	a	q	ü	æ	í	⋮	⌈	⌋	β	±
2	☺	↕	"	2	B	R	b	r	é	Æ	ó	⋮	⌈	⌋	Γ	≥
3	♥	!!	#	3	C	S	c	s	â	ô	ú	⋮	⌈	⌋	π	≤
4	♦	¶	\$	4	D	T	d	t	ä	ö	ñ	⋮	⌈	⌋	Σ	∫
5	♣	§	%	5	E	U	e	u	à	ò	Ñ	⋮	⌈	⌋	σ	∫
6	♠	■	&	6	F	V	f	v	ã	û	ä	⋮	⌈	⌋	μ	÷
7	•	↕	'	7	G	W	g	w	ç	ù	o	⋮	⌈	⌋	τ	≈
8	●	↑	(8	H	X	h	x	ê	ÿ	ï	⋮	⌈	⌋	ϕ	°
9	○	↓)	9	I	Y	i	y	ë	ö	Γ	⋮	⌈	⌋	θ	•
A	◉	→	*	:	J	Z	j	z	è	Ü	⌋	⋮	⌈	⌋	Ω	•
B	♂	←	+	;	K	[k	{	ï	ç	½	⋮	⌈	⌋	δ	√
C	♀	⌊	,	<	L	\	l	!	î	£	¼	⋮	⌈	⌋	∞	∞
D	♪	↔	-	=	M]	m	}	ì	¥	ì	⋮	⌈	⌋	φ	2
E	♪	▲	.	>	N	^	n	~	Ä	Pt	∅	⋮	⌈	⌋	€	■
F	☼	▼	/	?	O	_	o	Δ	Å	f	»	⋮	⌈	⌋	∩	BLANK FF

File No.:960-010

APPENDIX D
KEYBOARD SCAN/CHARACTER CODES

Table D-1 Keyboard scan/character codes

Cap No.	Key Top	Lower Case	Cap No.	Key Top	Lower Case	Cap No.	Key Top	Lower Case
1	ESC	01 1B	15	Tab	0F 09	35	H	23 68
2	! 1	02 31	16	Q	10 71	36	J	24 6A
3	@ 2	03 32	17	W	11 77	37	K	25 6B
4	# 3	04 33	18	E	12 65	38	L	26 6C
5	\$ 4	05 34	19	R	13 72	39	: ;	27 3B
6	% 5	06 35	20	T	14 74	40	" '	28 27
7	^ 6	07 36	21	Y	15 79	41	~ `	29 60
8	& 7	08 37	22	U	16 75	42	Shift (L)	-
9	* 8	09 38	23	I	17 69	43	\	2B 5C
10	(9	0A 39	24	O	18 6F	44	Z	2C 7A
11) 0	0B 30	25	P	19 70	45	X	2D 78
12	_ =	0C 2D	26	{ [1A 5B	46	C	2E 63
13	+ =	0D 3D	27	}]	1B 5D	47	V	2F 76
14	Back space	0E 08	28	Enter	1C 0D	48	B	30 62
			29	Ctrl	-	49	N	31 6E
			30	A	1E 61	50	M	32 6D
			31	S	1F 73	51	< ,	33 2C
			32	D	20 64	52	> .	34 2E
			33	F	21 66			
			34	G	22 67			

Table D-1 Keyboard scan/character codes (continued)

Cap No.	Key Top	Lower Case
53	? /	35 2F
54	Shift	-
55	PrtSc *	37 2A
56	Alt	-
57	Space	39 20
58	Caps Lock	-
59	F1	3B 00
60	F2	3C 00
61	F3	3D 00
62	F4	3E 00
63	F5	3F 00
64	F6	40 00
65	F7	41 00
66	F8	42 00
67	F9	43 00
68	F10	44 00
69	Num Lock	-
70	Scrol Lock	-
71	Home	47 00
72	↑	48 00
73	PgUp	49 00

Cap No.	Key Top	Lower Case
75	←	4B 00
77	→	4D 00
79	End	4F 00
80	↓	50 00
81	PgDn	51 00
82	Ins	52 00
83	Del	53 00
84	Sys Req	-
85	Fn	-

**APPENDIX E
KEY LAYOUT**

1. USA VERSION

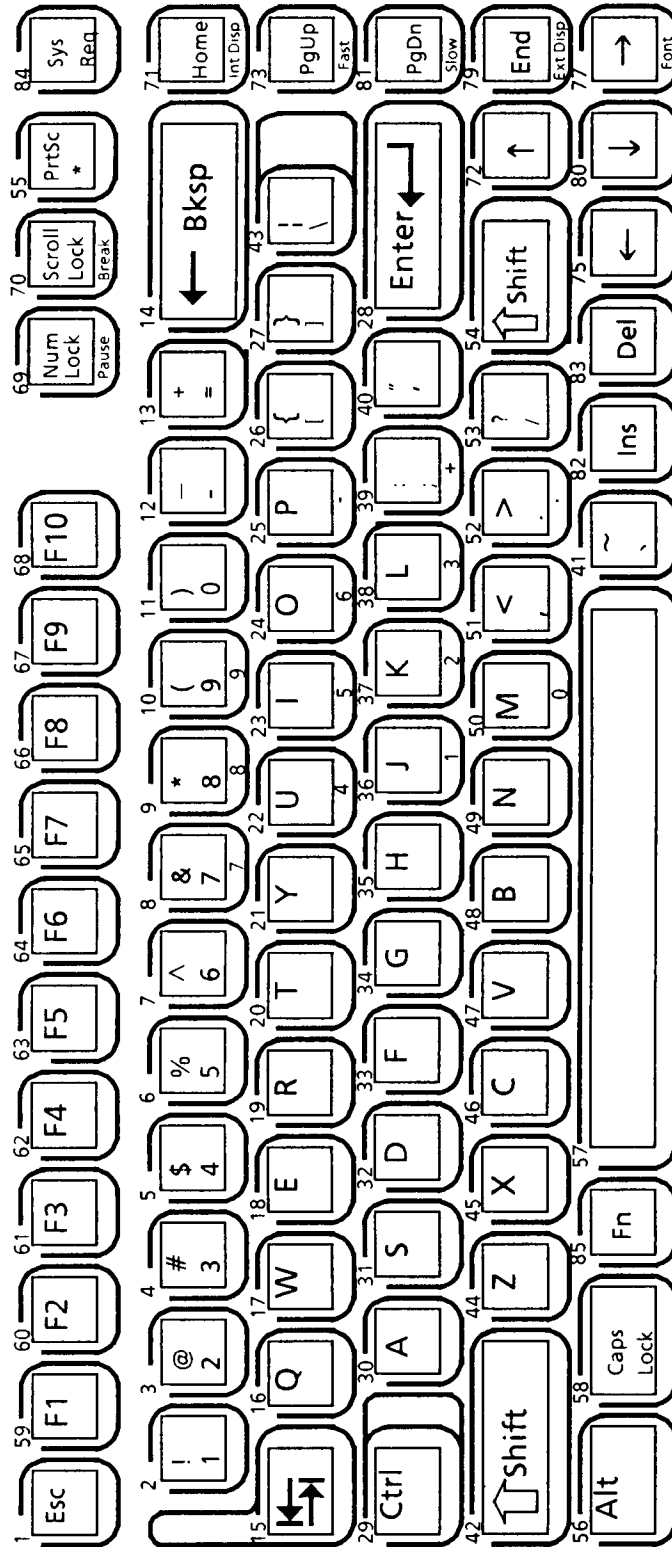

Replace key No. 3, 4, 40, 41

Figure E-1 USA version

2. UK VERSION

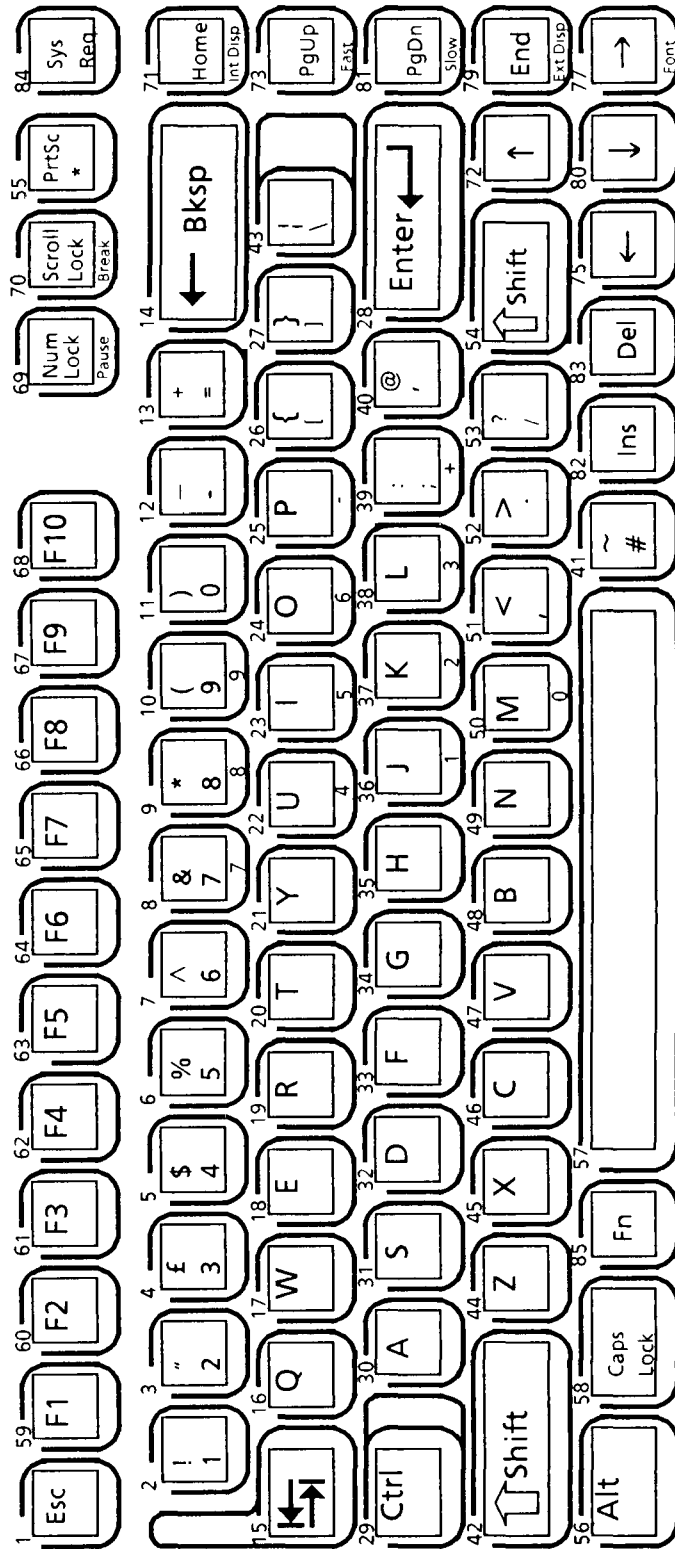
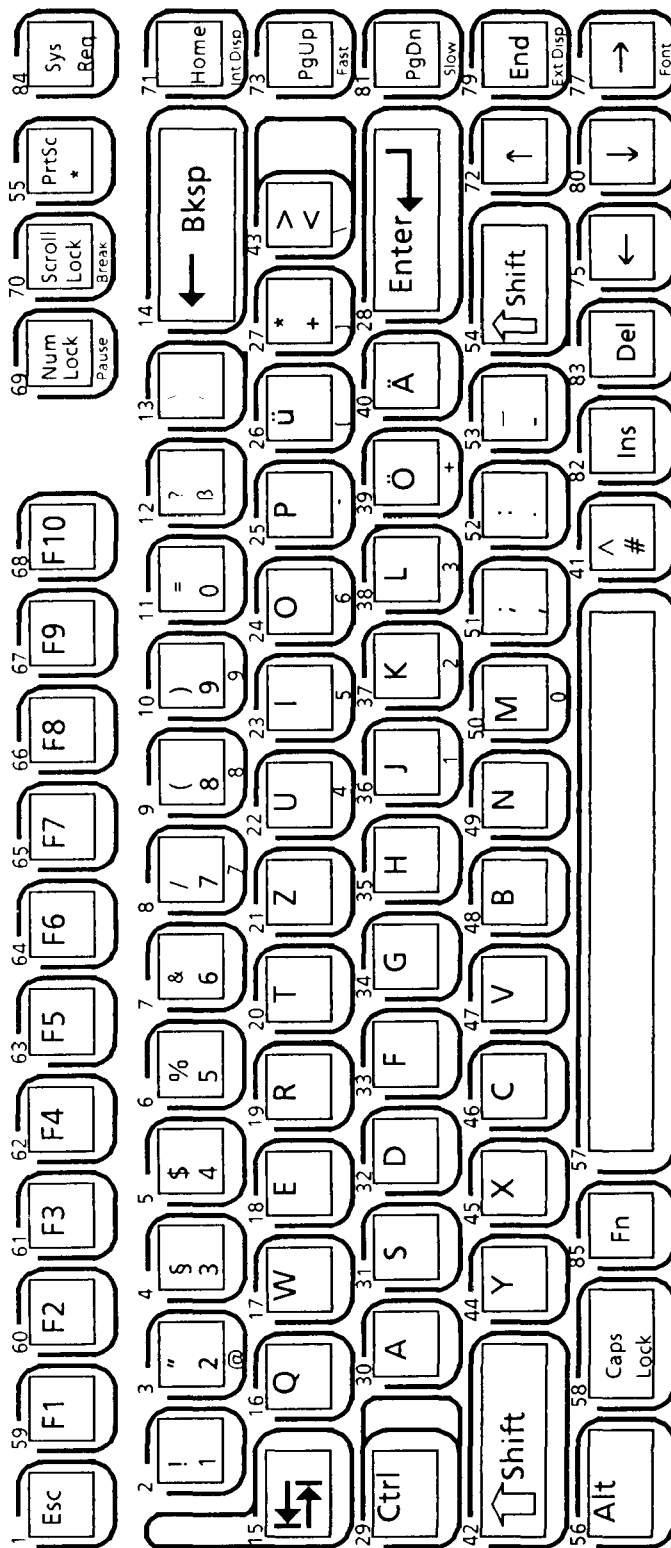

Figure E-2 UK version

3. GERMANY VERSION



Replace Key No. 3, 4, 7-13, 21, 26, 27, 39-41, 43, 44, 51-53

Figure E-3 Germany version

4. FRANCE VERSION

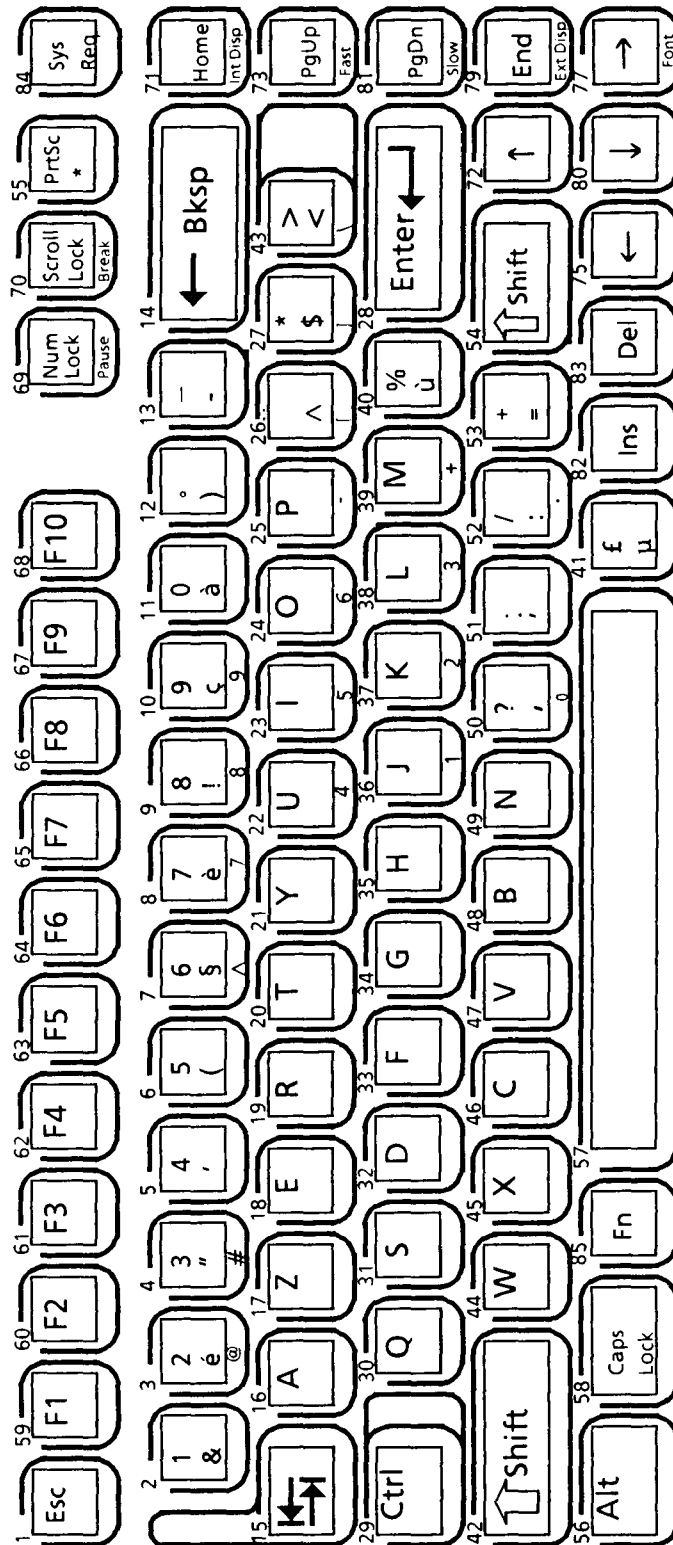

Replace Key No. 2-13, 16, 17, 26, 27, 30, 39-41, 43, 44, 50-53

Figure E-4 France version

5. SPAIN VERSION

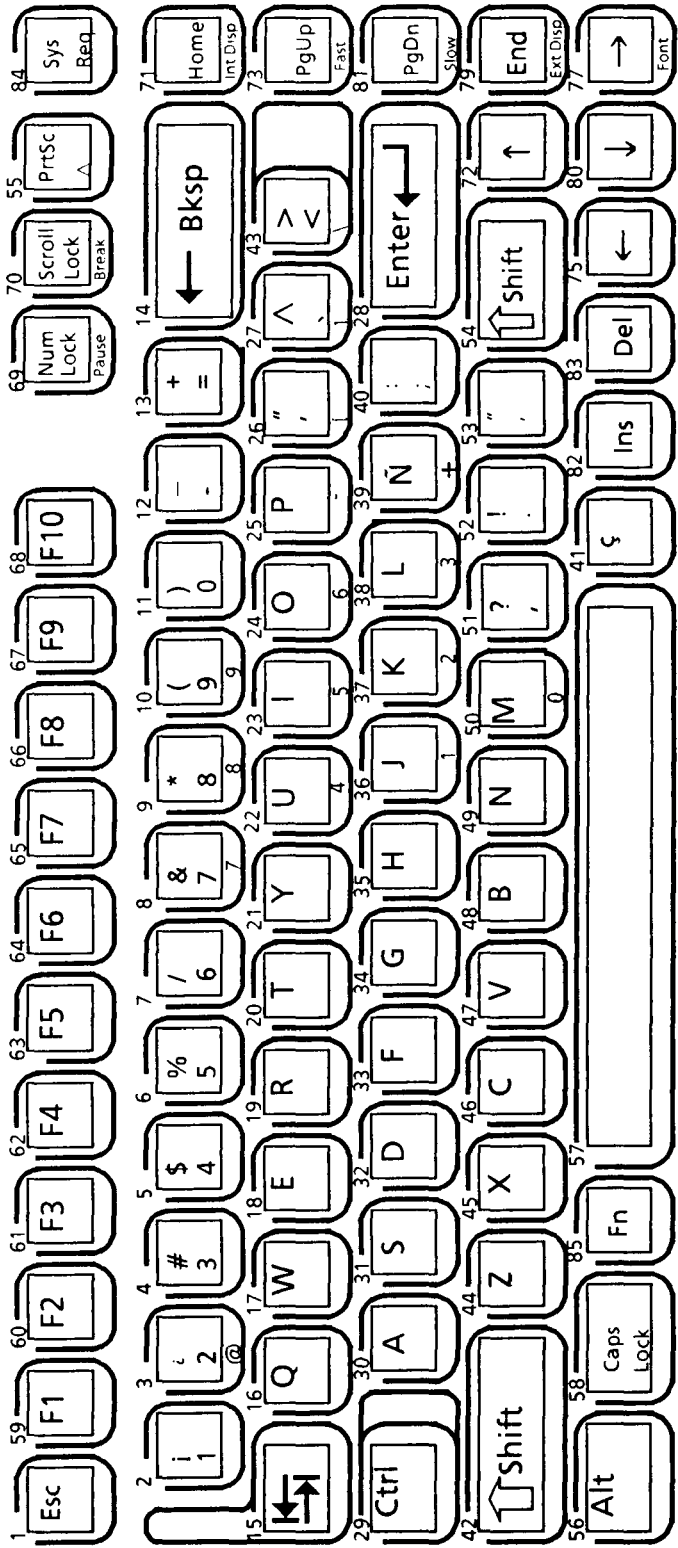

Replace Key No. 2-4, 7, 26, 27, 39-41, 43, 51-53, 55

Figure E-5 Spain version

6. ITALY VERSION

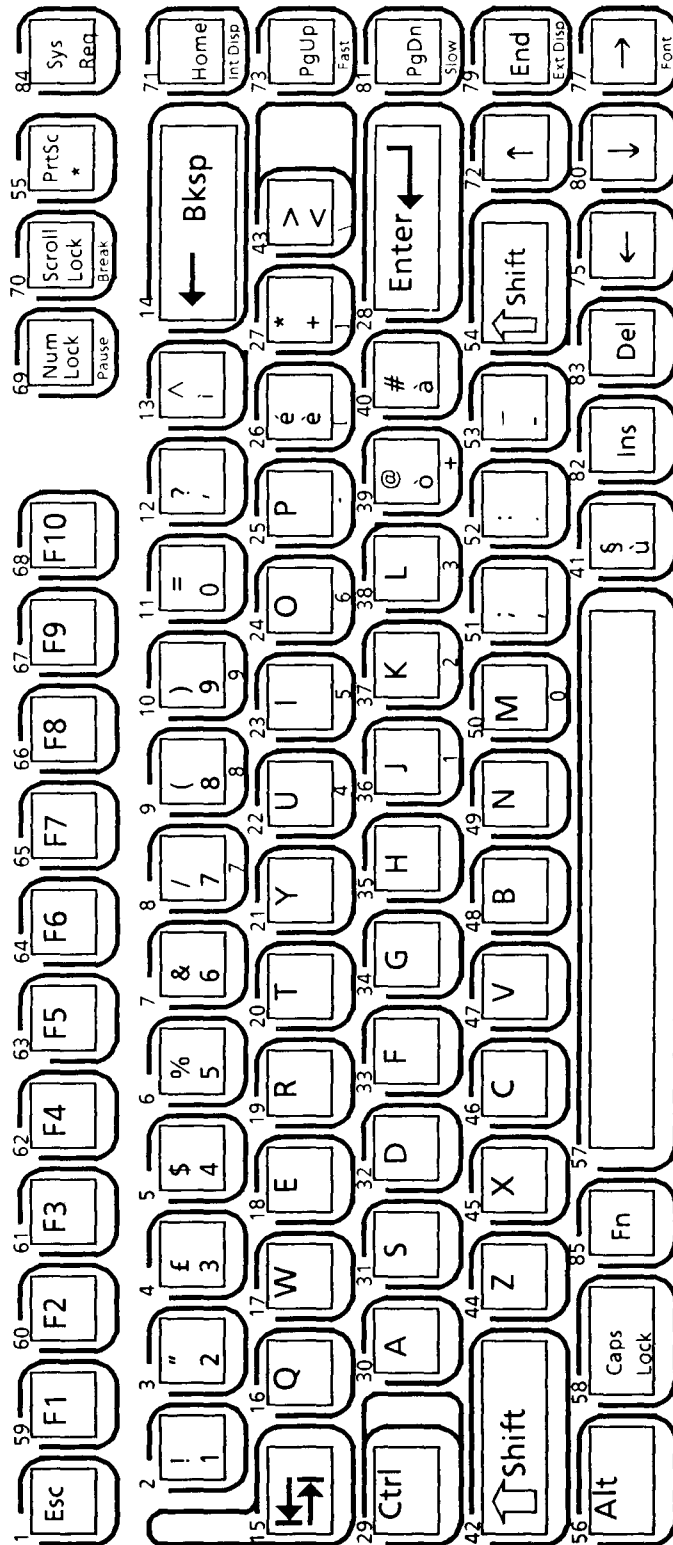

Replace Key No. 7-13, 26, 27, 39-41, 43, 51-53

Figure E-6 Italy version

7. SCANDINAVIAN VERSION

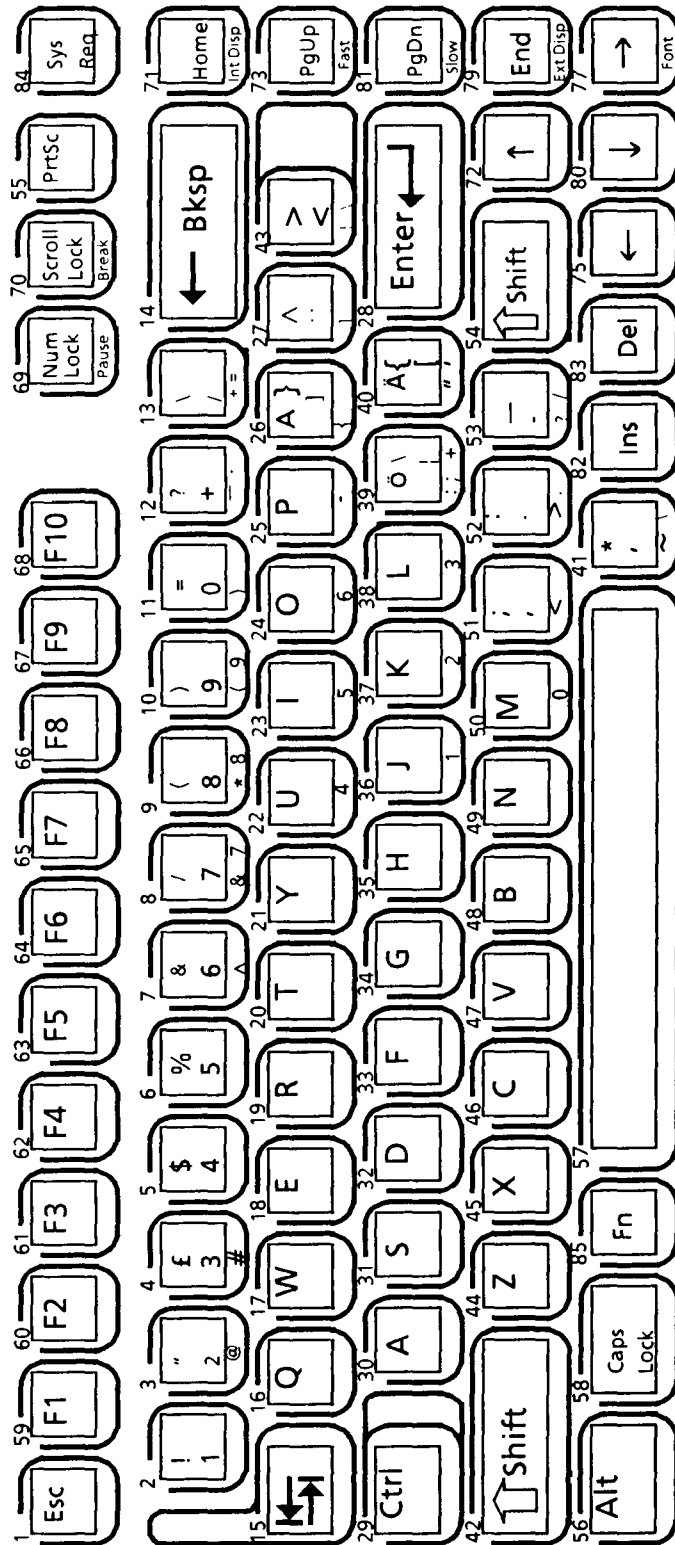

Replace Key No. 3, 4, 7-13, 26, 27, 39-41, 43, 51-53, 55

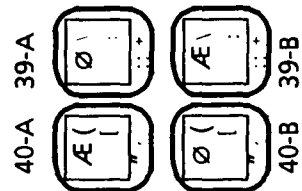
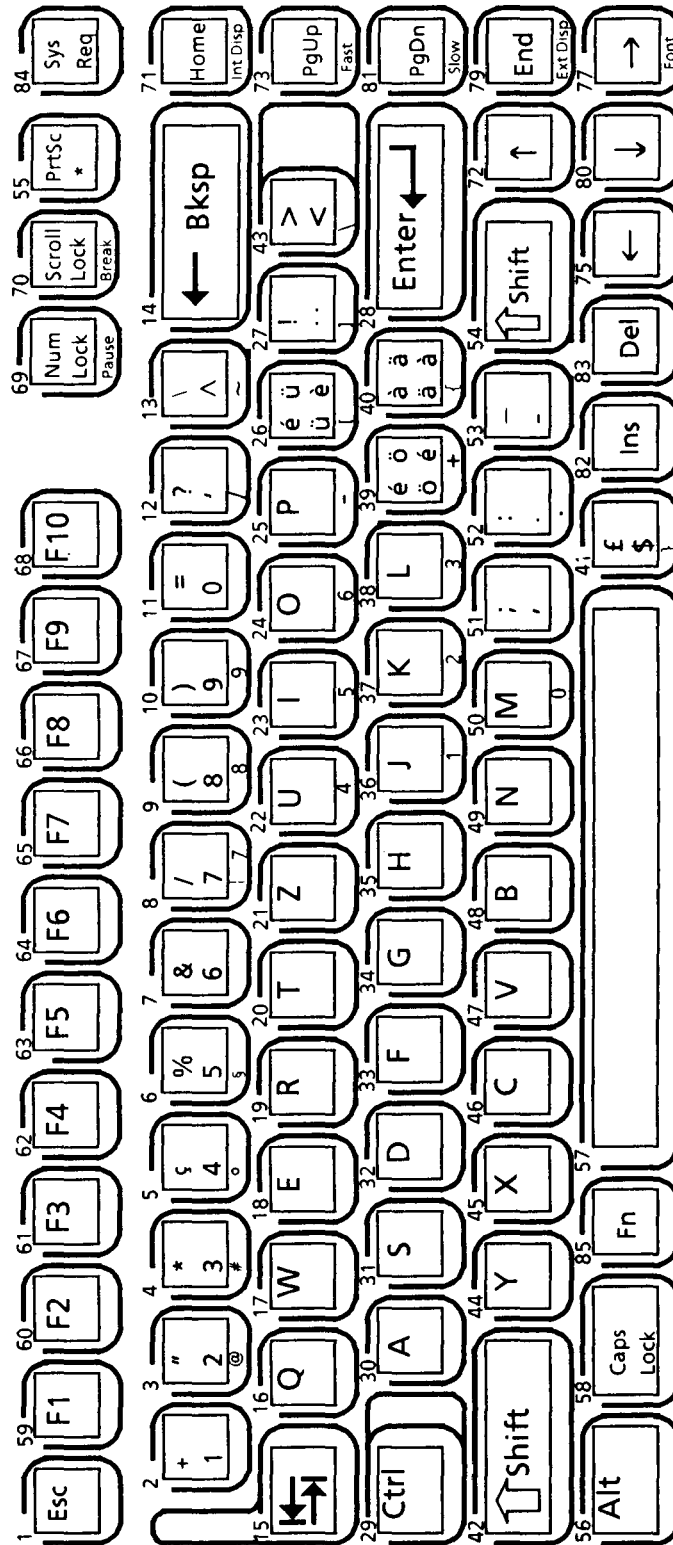

Figure E-7 Scandinavian version

8. SWITZERLAND VERSION



Replace Key No. 2-13, 21, 26, 27, 39-41, 43, 44

Figure E-8 Switzerland version

9. KEYCAP NUMBERS

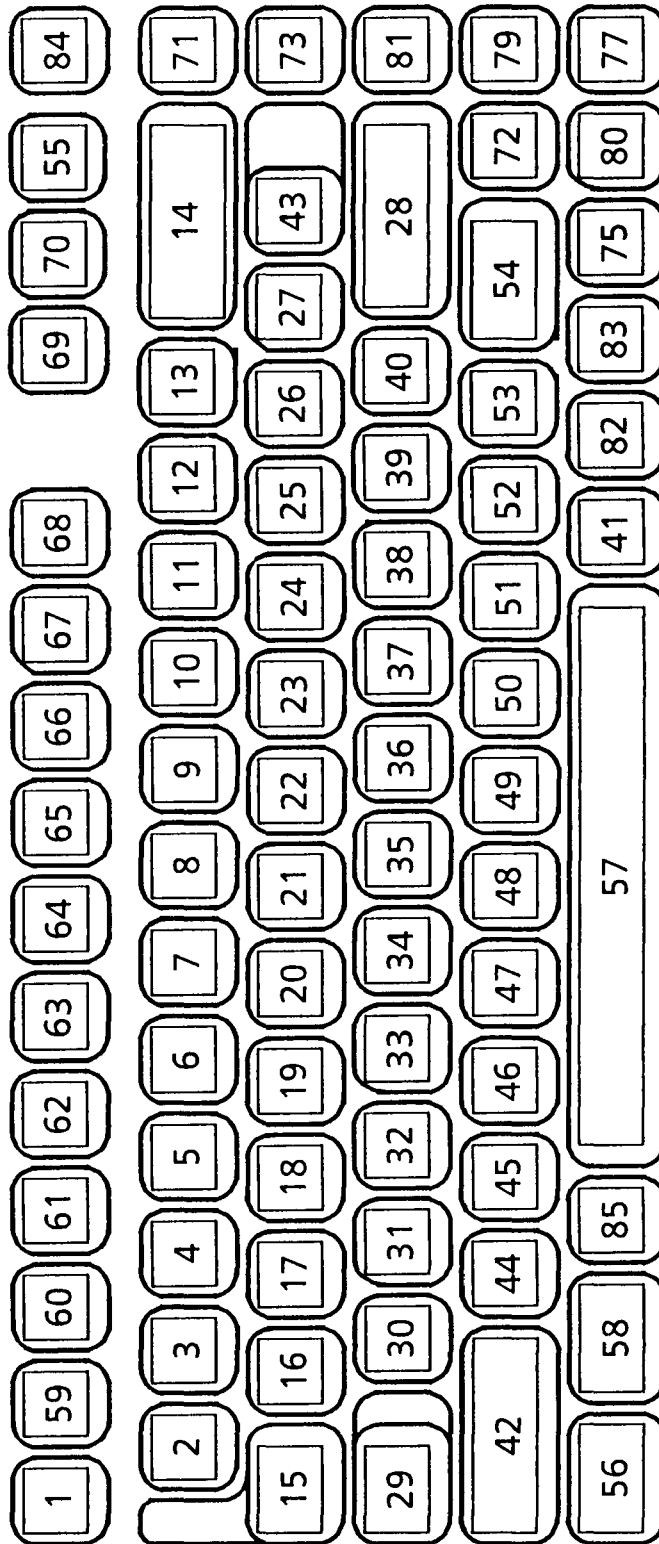

Figure E-9 Keycap number