

# SHARP SERVICE MANUAL

CODE : 00ZPCA290SM-E

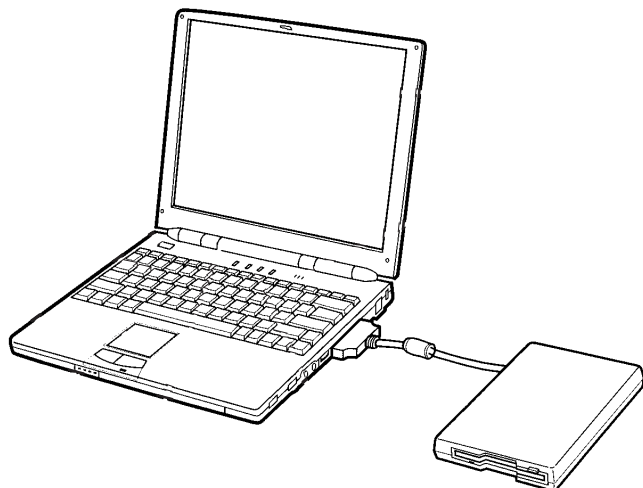

## PERSONAL COMPUTER

## MODEL PC-A290

### CONTENTS

CHAPTER 1. OUTLINE.....	1 - 1
CHAPTER 2. SPECIFICATIONS .....	2 - 1
CHAPTER 3. DISASSEMBLY AND REASSEMBLY .....	3 - 1
CHAPTER 4. PRECAUTIONS .....	4 - 1
CHAPTER 5. RE-INSTALLATION .....	5 - 1
CHAPTER 6. DIAGNOSTICS .....	6 - 1
CHAPTER 7. TROUBLESHOOTING .....	7 - 1
CHAPTER 8. BLOCK DIAGRAM .....	8 - 1
CHAPTER 9. CIRCUIT DIAGRAM AND PARTS LAYOUT .....	9 - 1

Parts marked with "△" are important for maintaining the safety of the set. Be sure to replace these parts with specified ones for maintaining the safety and performance of the set.

### **Caution about Battery**

**Caution** : Danger of explosion if battery is incorrectly replaced. Replace only with the same or equivalent type recommended by the manufacturer. Discard used batteries according to the manufacturer's instructions.

**Attention** : Il y a danger d'explosion s'il y a remplacement incorrect de la batterie. Remplacer uniquement avec une batterie du même type ou d'un type recommandé par le constructeur. Mettre au rebut les batteries usagées conformément aux instructions du fabricant.

# CHAPTER 1. OUTLINE

## Superior Power

The PC-A290 offers premium system performance in its class, with a 366MHz Mobile Pentium® II PE processor, 64MB of SDRAM standard, a 9GB Hard Drive, 2.5MB of Video Memory; and built-in 10/100 Ethernet. The perfect solution for even the most demanding computing tasks.

## The World Leader in LCD Technology

At the heart of the A290 is Sharp Electronics Corporation's 11.3" XGA TFT Liquid Crystal Display. As the industry leader in LCD's, Sharp has incorporated their latest display technology (known as AGAR) to reduce glare while at the same time, increasing viewing angle. The incredibly bright AGAR display produces the richest possible colors (over 16 million) with "you have to see it to believe it" clarity. The PC-A290 is always easy on the eyes with 1,024 x 768 resolution, even after many hours of use. No more squinting or watery, tired eyes. The Sharp PC-A290 offers the largest, most comfortable and best Liquid Crystal Display in its class.

## Extra-Long Computing Power

Full-featured mobile computing usually has its limitations – battery life. But the A290 has power to spare. The A290 comes with an internal Lithium-Ion battery that provides up to 2 hours of computing time.

- Approximately 2 hours (standard internal battery only)
  - Approximately 4 hours (with flat panel battery (CE-BP01) connected)
  - Approximately 6 hours (with external battery pack (CE-BL03) connected)
- \* battery life varies depending on usage

## All the Right Connections

The A290 includes a 10/100 Ethernet port, 2 Universal Serial Bus (USB) ports, 1 Type II PC Card slot, an external monitor port for convenient connections to larger displays and LCD projectors, an IrDA Fast Infrared (4Mbps) port for wireless communications, a power-efficient 56K modem, a Microphone In port and a headphone jack and built in microphone and speaker.

Included with each PC-A290 is an external Floppy Disk Drive/Port Replicator Combination Unit. On board this unit is a Serial, Parallel and PS/2 port with only a single cable connection to your PC. Thus the unit can connect to the office printer, mouse and other peripherals quickly and easily without having to connect multiple cables to the back of the PC.

## Overview of Computer

Each number after an arrow indicates the page referring to the part. Actual appearance of your computer may be slightly different depending on the model.

### Front

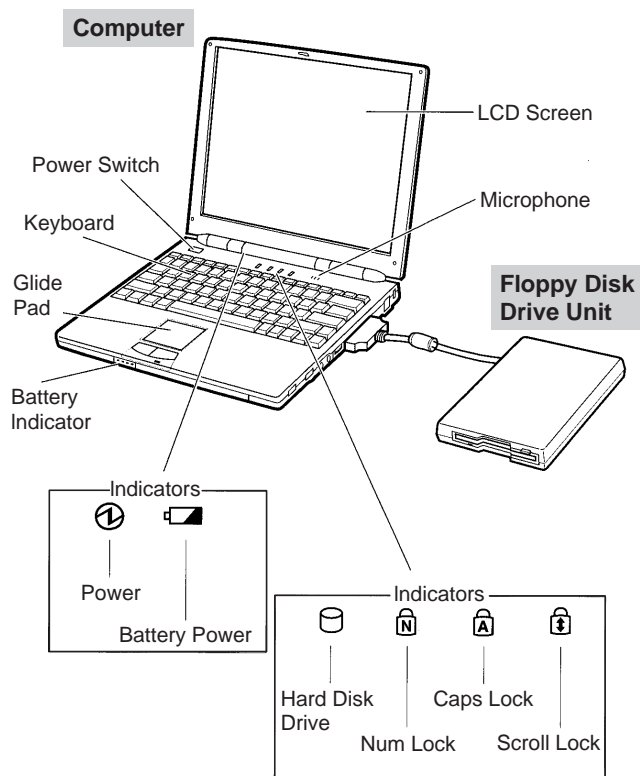

### Right

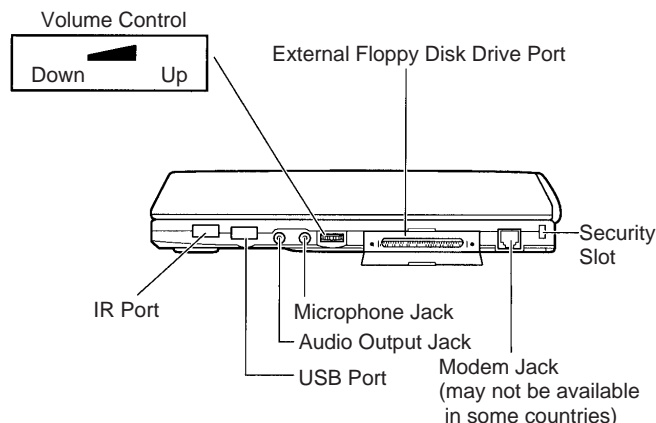

### Left

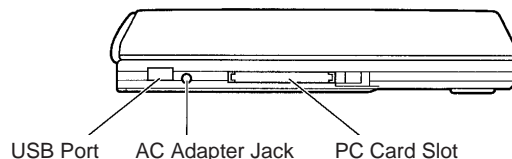

**Rear**

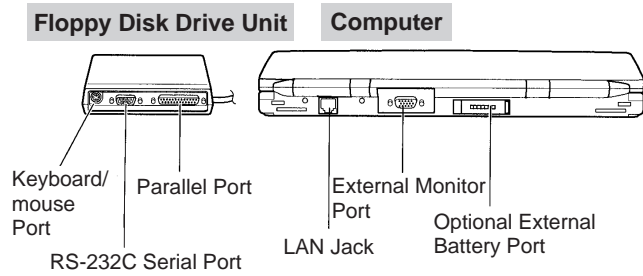

**Bottom**

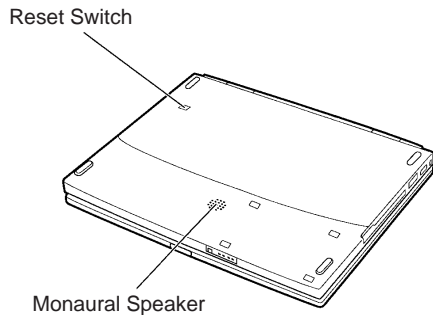

**Basic Operations**

This chapter describes the basic operations of your computer.



**Choosing Power Source**

You can use the computer with one of the following power sources:

- AC power from a wall outlet  
Use AC power whenever possible; rely on the battery only when AC power is not available.
- Rechargeable battery  
There is an internal standard battery in the computer. You can use an optional external battery pack adding to the standard battery.

**About the Power Indicators**

The following indicators show the power status of your computer.

Indicator	Light	Meaning
	On (green)	Fully charged
	On (orange)	Being charged
	Blinking (orange)	In abnormal state
	Blinking (red)	Almost completely discharged. The warning beep sounds.
	On (green)	Operating
	Blinking (green)	Standby
	Off	Hibernation or powered off

**Using the AC Adapter**

When connected to a wall outlet, the AC adapter provides power for operation and charges the battery. The AC input voltage can range from 100 to 240 volts so that you can use the computer with the appropriate plug adapter.



The AC power cord included with the computer is appropriate for the voltage used in the area in which you purchased your computer. If you attempt to connect the computer to a wall outlet other than in this area, check the voltage of the outlet and use an AC power cord appropriate for the outlet. Consult local service staff if you are unsure.

**Resetting the System**

You may need to reset the system after adding hardware or software so that your computer will recognize the newly installed devices or software. When the message appears after the installation, click OK, Yes, etc. to restart Windows 98.

You can also restart Windows 98 from the Start menu. Select Shut down; then, Restart.

**Warm Boot (Software Reset)**

If the system is locked up because of a software problem, you can reset or reboot the system by pressing the Ctrl+Alt+Del keys simultaneously. Press the Ctrl+Alt+Del keys again to restart the computer.



Resetting may cause data loss. Use the software reset only if the normal Windows 98 Shut Down does not work because of software malfunction. Although resetting will not damage the system, you may lose the data you are processing.

**Power Switch**

You can turn off the computer with the power switch if you encounter hardware or software problems which lock up the system. In this case, press the switch for more than six seconds.

**Reset Switch**

If you cannot turn off the computer by pressing the power switch, you can use the reset switch on the bottom of your computer. To reset the system, insert a narrow object into the small hole to slide the switch as shown.

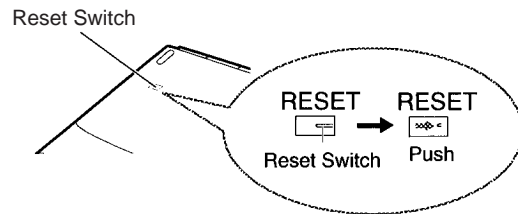

Do not use metallic materials to slide the reset switch. It may cause malfunction.

**Using The Glide Pad**

Your computer is equipped with an integrated pointing device called a glide pad. Using the glide pad, you can move the pointer, select an item from a menu, and perform other tasks in the same way you would with a mouse.



- Do not hit or scratch the surface of the glide pad with pointed objects (such as a ballpoint pen).
- Do not operate the glide pad with a moist finger. This may cause the glide pad to operate incorrectly.
- You cannot use the glide pad when a mouse is connected.

## Using the Glide Pad

Take a moment to become familiar with how the glide pad works.

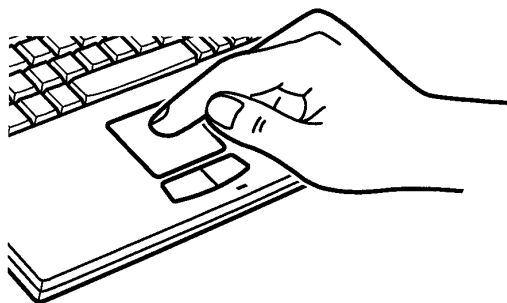

### Place Your Fingertip

Place your left or right hand next to the glide pad, resting your wrist naturally in a relaxed manner. Place your thumb or finger on the glide pad.

### Move Your Fingertip

The rectangular pad of the glide pad acts like a miniature duplicate of the display. As you slide your fingertip across the pad, the pointer on the screen moves in the same direction across the screen. The glide pad is very sensitive, so you do not have to exert much pressure on the pad. The glide pad will respond to a light touch from your fingertip.

### Click, Double-click, and Right-click

To click or double-click, you can use the left button just like that of a mouse. Instead of clicking the left button, you can also just tap gently anywhere on the rectangular pad. For right-clicking, you must use the right button.

### Drag and Drop

You can move icons or windows by using "drag and drop" below:

1. Position the pointer over the object.
2. Press the left button; do not release it.
3. Holding down the button, move the pointer. The object moves together with the pointer.
4. Release the button when the object reaches its destination.

### Scroll

You can scroll through information in a list or in a document by using the glide pad. Place your finger on the most right part of the glide pad and slide your finger up and down. This procedure works only vertically, and in limited applications.

### Changing the Configuration

In the Mouse Properties dialog box, you can change the configuration of the glide pad, such as swapping left and right buttons, changing the pointer size, etc.



- If you swap the left and right buttons, "tapping" on the glide pad as an alternative method of pressing the left button will no longer function.
- If you prefer to use a mouse and turn off the glide pad, you can disable the glide pad in the Setup Utility. See also Chapter 4.

## Using The Keyboard

Your computer, equipped with the Windows Enhanced Keyboard, provides all the functionality of a full-sized desktop keyboard.

### Windows Logo Keys



Opens the Windows Start menu.



Opens an application-specific short-cut menu equivalent to right-clicking.

## System Function Keys

When pressed together with the Fn key, function keys set specific system parameters. This combination is sometimes referred to as "hot keys".



Switches the display output between the LCD screen and external monitor (if connected). See the Display section in Chapter 4 for details.



Decreases the LCD screen brightness.



Increases the LCD screen brightness.



Turns the screen backlight on and off.



Puts the computer in System standby (to Standby or to Hibernation, according to the setup selection). See also Chapter 3.

## Using External Floppy Disk Drive Unit

You can use double-density (2DD) 720KB or high-density (2HD) 1.44MB floppy disks with the external floppy disk drive unit.

The keyboard/mouse port, RS-232C serial port and parallel port are available on the rear side of the floppy disk drive unit. You can connect peripherals to the floppy disk drive unit. For more information about peripherals, refer to Chapter 4.

### Connecting External Floppy Disk Drive Unit



Turn off the computer before connecting the external floppy disk drive unit; otherwise the floppy disk drive unit may not be recognized.



- Do not place the floppy disk drive unit on its side or upside down.
- Do not press on the floppy disk drive unit. It may damage the drive or cause malfunction.
- Do not place the AC adapter on the floppy disk drive. It may cause the drive to malfunction.

1. Turn off the computer.
2. Open the cover of the external floppy disk drive port on the right side of the computer.
3. Connect the connector of the floppy disk drive unit to the floppy disk drive port.

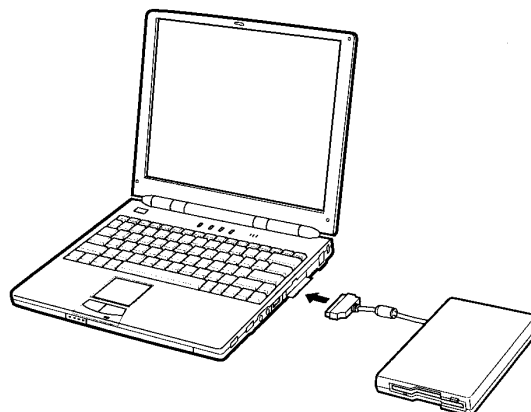

## Removing External Floppy Disk Drive Unit

1. Remove the floppy disk from the floppy disk drive.
2. Turn off the computer.
3. Disconnect the floppy disk drive unit by simultaneously pressing the buttons on each side of the connector and pulling it out.
4. Close the cover of the floppy disk drive port on the computer.

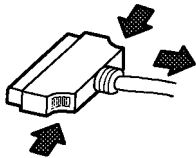

## Handling Floppy Disks

- Do not open the shutter and touch the disk inside; otherwise, you will not be able to read or write data to the disk.
- Do not place floppy disks near magnets or heat source, in direct sunlight or in a dusty place, etc.
- Never subject a disk to sudden shocks or extreme vibration. Do not drop, bend, or place heavy objects on a disk.
- Do not spill liquid onto a disk.

## Inserting and Removing a Floppy Disk

### Inserting

Hold the floppy disk with the arrow facing up and towards the drive. Slide the disk into the drive until it locks into place.

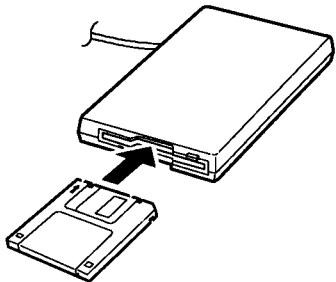

- Always insert a floppy disk straight into the floppy disk drive.
- When inserting the disk, make sure it is not upside down.
- Do not use excessive force when inserting the floppy disk. If you have difficulty inserting or removing disks, seek the assistance of an authorized service technician.

### Removing



Before removing the floppy disk, make sure the indicator of the floppy disk drive unit is not lit.

Press the eject button firmly. The disk will pop out slightly. Remove it and store it properly.

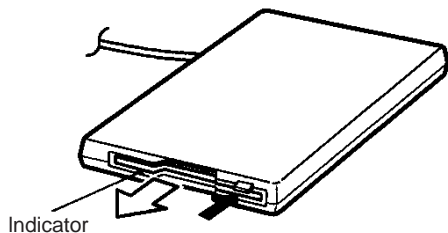

## Formatting a Floppy Disk

1. Make sure the floppy disk is not write-protected, and insert it into the floppy disk drive.
2. Double-click My Computer on the desktop.
3. Click 3 1/2 Floppy [A:]. From the File menu, select Format.
4. From the capacity drop-down list, select 1.44MB or 720KB.
5. Click Start to start formatting.



When you format a floppy disk, all data previously stored on the disk is lost.

## Backing Up Data

We recommend that you regularly backup the data on your hard disk drive. Windows 98 has a backup function you can use to back up your data. See Windows 98 Help for details.

## Battery and Power Management

This chapter explains how to manage the computer's power effectively and use the standard battery or an optional battery pack.

### Standard Battery Pack

When not connected to an external power source, your computer operates with the rechargeable internal standard battery pack. The duration of the battery life may be longer if the computer's Power Management is active. See the next section for power management.

To keep the battery life long:

- Initialize the battery pack if the actual remaining power in your battery is less than what the battery indicator lights suggest as per the procedure.
- Turn off your computer when you are not using it.
- The duration a battery charge will last will depend on the computer usage. Applications which heavily use the peripherals will experience shorter power duration.
- When the battery is not charged, your computer may not operate properly. Connect the AC power to charge the battery.
- If you see an error message during booting, press F2 to open the Setup Utility. Following the instructions in Chapter 7, adjust the Setup Utility and restart the system.
- When using the computer for several hours with battery packs, enable power management and set System standby. Refer to the Power Management section in this chapter.







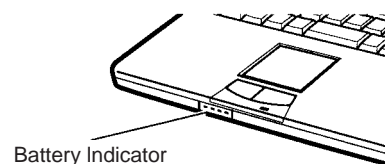

### Checking the Battery Level

You can check the battery level in the Power Management Properties dialog box in the Control Panel or double-clicking the battery or AC plug icon on the taskbar.

You can also check with the battery indicator on the front side of the computer.



Press the button on the right of the battery indicator to show the battery power remaining. Refer to the table below.

Battery Indicator Status	Capacity Remaining
 All on	76% – 100%
 Three on	51% – 75%
 Two on	26% – 50%
 One on	1% – 25%
 One blinking	Nearly 0% (Empty)
 All off	0% (Empty)

This battery indicator turns on automatically while the battery is being charged (when connected to AC power). When the battery is fully charged, the battery indicator turns off.



The battery power remaining is an approximate figure. The remaining operating time expected may be different from the actual remaining time, depending on the use of the computer. If the actual remaining power in your battery is less than what the battery indicator lights suggest, you should initialize the battery pack.

### Low Battery Indication

When the battery power becomes significantly low, the battery power indicator () turns red and the warning beep sounds. Save your data and turn off the computer, or connect the computer to AC power immediately. Otherwise, the computer will be shutdown and the data may be lost. If you set the battery alarm in Windows 98, the computer will be turned off or enter System standby in case of significantly low battery power. See Power Management section of this chapter.

The remaining operating time depends on the power you are consuming. If you are using the audio system, PC card slot, hard disk, floppy disk or CD-ROM, your computer may consume more battery life.



See also the section on power management in this chapter.

### Charging the Battery Pack

1. Connect the AC adapter to the computer. While the battery is being charged, the battery power indicator is orange and the battery indicator turns on.
2. When the battery is fully charged, the battery power indicator turns green and the battery indicator turns off. Charging time may vary according to the status of the computer.



When the battery is hot (for example, after long use), it may take longer to fully charge the battery.

### Initializing the Standard Battery Pack

You need to initialize the battery pack when the actual remaining power in your battery is less than what the battery indicator lights suggest.

1. Make sure the computer is turned off. Connect the computer to AC power and wait until the battery is fully charged. The battery power indicator turns green and the battery indicator turns off. It will take about 2 hours and 30 minutes if the battery was previously completely discharged.
2. Turn on the computer.
3. When the message Press <F2> to enter Setup Utility appears, press F2 to open the Setup Utility.
4. Disable the power management and set Critical Battery Suspend to Disabled in the Power menu of the Setup Utility. See Power menu in Chapter 7.
5. Press Esc; then Enter twice. The system restarts.

6. When the message Press <F2> to enter Setup Utility appears, press F2 to open the Setup Utility. Leave the computer in the Setup Utility.
7. Disconnect the AC adapter, and leave the computer on until the battery is completely discharged and the system shuts down automatically. It will take about 3 hours.
8. Connect the computer to AC power and let the battery fully charge.



- Do not connect the computer to wall outlet while discharging the battery. The initialization will be cancelled.
- You can initialize the standard battery alone if the optional external battery pack is disconnected. When the external battery pack is connected, both the standard and the external battery will be initialized together.

### Changing the Battery Pack

The capacity of a battery pack gradually decreases when used repeatedly (the deterioration rate depends on the operating temperature and environment). If the battery life becomes extremely short even after the initialization, you should change the standard battery pack. Bring your computer to a local dealer for replacement of the standard battery pack.



Never replace the standard battery pack by yourself.

### Optional Batteries

To power your computer for extended periods of time, there are two available optional batteries, the external battery pack(CE-BL03) or the flat panel battery(CE-BP01).



- Use only the appropriate optional battery (CE-BL03 or CE-BP01), and attach it correctly.
- You cannot use the external battery pack(CE-BL03) and the flat panel battery(CE-BP01) at the same time. Only one external battery may be connected at any given time.

### Connecting External Battery Pack

1. Slide the cover of the external battery port to locate the port.

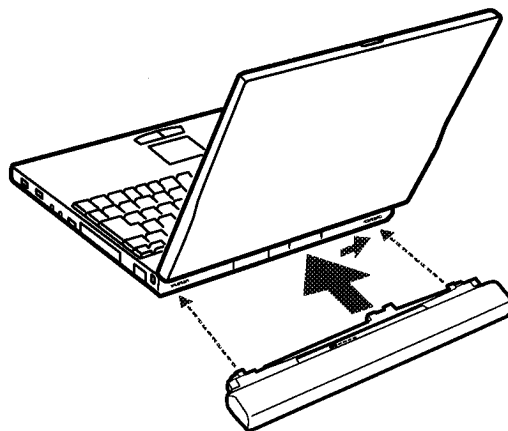

2. Connect the optional battery by matching the projections on either side of the battery to the notched parts of the computer. Make sure that the battery connector lines up with the external battery port of the computer. If you hear a clicking sound, the external battery pack should be correctly connected.



- While the external battery pack is connected, do not carry the computer by holding the battery pack only. Firmly hold both the computer and the external battery pack.
- You cannot connect an external monitor nor a LAN cable when the external battery pack is connected.

## Removing External Battery Pack



Before removing the external battery pack, turn off the computer or confirm that the standard battery pack has power remaining. If the standard battery pack has no power remaining, connect the computer to AC power; otherwise the computer will be shut down and data may be lost.

Remove the optional battery by pressing the buttons on each end of the battery and sliding the battery off the computer.

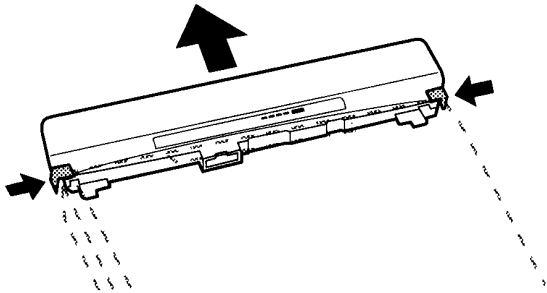

Close the cover of the external battery port after the external battery pack is removed.

## Checking the Battery Level

You can check the battery level of the external battery pack (in the same way as the standard battery pack) with the battery indicator. Press the button on the right of the indicator. The status of the indicator is the same as that of the standard battery.

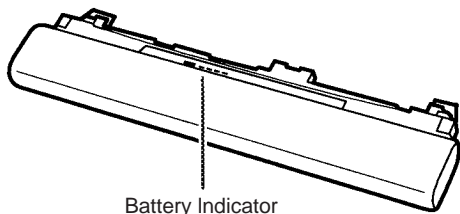

Battery Indicator

## Charging External Battery Pack

You can charge the external battery pack by connecting AC power to the computer with the external battery connected.

To charge most effectively, the standard and external battery pack will be charged as follows:

1. Charge standard battery pack to about 80%.
2. Charge external battery pack to about 80%.
3. Charge standard battery pack remaining 20%.
4. Charge external battery pack remaining 20%.

When the computer is turned off or in Hibernation, it will take about 5 hours and 30 minutes to charge both the standard and external battery packs from empty to full. When the computer is turned on, it will take about 7 hours and 30 minutes. (The charging time depends on the power you are consuming.)

## Initializing External Battery Pack

The procedure for initializing an external battery pack is the same as that of the standard battery. But, you cannot initialize the external battery pack only. If you begin the initializing process, both standard and external battery packs will be initialized.

## Power Management

Power management saves electricity and extends battery life by controlling power supply to built-in devices. You can set the following

power management properties in Windows 98.

- Stopping power supply to the hard disk
- Stopping power supply to the display
- Using System standby



Note that the power management may not seem to function under the following conditions:

- When you are using an application program that accesses the hard disk periodically
- When Windows CD Auto Play is functioning

## Stopping Power Supply to the Hard Disk

1. In the Power Management Properties dialog box, select Power Schemes tab.
2. Set Turn off hard disks to an appropriate value, and click OK.

## Stopping Power Supply to the Display



This procedure is also effective for an attached external monitor complying with power management.

1. In the Power Management Properties dialog box, select Power Schemes tab.
2. Set Turn off monitor to an appropriate value, and click OK.

## Using System Standby

System standby is a very useful power management tool. For example, after your computer has entered standby mode, you can restart your computer within much reduced time compared to when you turn on the computer again after shutting it down normally. When your computer resumes from System standby, the system restores the exact last state of the computer. There are two types of System standby; Standby and Hibernation. In Windows 98, you can define which System standby the system enters under what conditions.

- Standby stores the current condition of the computer in RAM and stops power supply to all but a few essential components. Your system enters and resumes from Standby per the conditions mentioned below. In Standby, the Power indicator blinks green.
- Hibernation saves the current condition of the computer in an area of the hard disk and turns off the computer. Your system enters and resumes from Hibernation per the conditions mentioned below. In Hibernation, the Power indicator turns off.

You can select Standby or Hibernation in Windows 98. See Selecting System Standby Mode below.

## Selecting System Standby Mode



- If your battery becomes completely discharged during Standby, you will lose unsaved data and will need to reboot your computer. Therefore, if you are planning to leave your computer powered by battery for long periods of time, we recommend Hibernation.

1. From the Start menu, select Settings - Control Panel.
2. Double-click Power Management icon.
3. In the Power Management Properties dialog box, select Hibernation tab.
4. Check Enable hibernation support if you want to support Hibernation. Uncheck if you want to support Standby.
5. Click Apply.
6. Click OK.

## Entering System Standby



- Finish communications, printing, and playing music or video before entering System standby.
- Do not operate the keyboard, glide pad or mouse while the system is entering System standby.

- When the system enters Hibernation, you can see some flicker on the display. This is not a malfunction.
- Save your data before your computer enters Standby. If the power supply to the computer is stopped, the RAM contents will be lost.

Your computer enters System standby in each of the following cases.

- You select Stand by in the Shut Down Windows dialog box.
- The specified time in System standby in Power Schemes tab of Power Management Properties dialog box has passed without any operation.

In the above two, your computer enters Standby or Hibernation depending on your selection in Selecting System Standby Mode of this chapter.

- The screen cover is closed.

The above functions if you perform the following:

1. In the Power Management Properties dialog box, select Advanced tab.
  2. Select Hibernate or Standby in When I close the lid of my portable computer:
  3. Click Apply.
  4. Click OK.
- You press the power switch.

The above functions if you perform the following:

1. In the Power Management Properties dialog box, select Advanced tab.
  2. Select Hibernate or Standby in When I press the power button on my computer:
  3. Click Apply.
  4. Click OK.
- You press Fn + F12.

The above functions if you perform the following:

1. In the Power Management Properties dialog box, select Advanced tab.
  2. Select Hibernate or Standby in When I press the sleep button on my computer:
  3. Click Apply.
  4. Click OK.
- The battery level is low.

The above functions if you set the alarm in Windows 98. See Battery Alarm in this section.

### Resuming from Standby



- Do not operate the keyboard, glide pad or mouse while the system is resuming from Standby.

Your computer resumes from Standby in each of the following cases:

- You press any key.
- The screen cover is opened.
- The built-in modem receives a call while a communication software is running (the built-in modem may not be available in some countries).

### Resuming from Hibernation



- Do not operate the keyboard, glide pad or mouse while the system is resuming from Hibernation.
- If sufficient battery power does not remain, your computer will not resume from Hibernation. To resume it, connect the computer to AC power.
- When the system resumes from Hibernation, you can see some flicker on the display. This is not a malfunction.

Your computer resumes from Hibernation if you press the power switch.

### Disabling Power Management

1. In the Power Management Properties dialog box, select Power Schemes tab.
2. Set System standby, Turn off monitor and Turn off hard disks to Never, and click OK.



When you are using communication software or if sound or voice pauses or skips while played back, disable power management.

### Battery Alarm

In Windows 98, the alarm will tell you when the battery drops to the specified level by sounding an alarm or displaying a message, and let your computer go on System standby or be shut down automatically.

1. From the Start menu, select Settings - Control Panel.
2. Double-click Power Management icon.
3. Select Alarms tab.
4. Set the battery level at which the alarms are activated and the Alarm Action desired.
5. Click OK twice.

## Security Features

This chapter describes how to protect your computer against unauthorized use, computer viruses and theft.

### Passwords

Setting a password will help protect against unauthorized access to your computer. When a password is set and the computer is turned on or resumes from the suspend-to-disk mode, the system will require a password.



If you lose your password, you will be unable to access the computer or change the configuration. Make sure you select a password you will never forget, and write it down and save it in a secure place. Otherwise, you will have to contact your dealer for assistance.



If you enter a wrong password three times, the message System Disabled appears. Press the power switch to turn off the computer, turn it on again, and enter the correct password.

### Supervisor Password and User Password

Two types of passwords limit the access at different levels. To set the user password, you always have to set the supervisor password. When you set the two passwords, a person who knows only the user password has the limitations below:

## When setting items in the Setup Utility

The person who does not know the supervisor password cannot set:

- |               |   |
|---------------|---|
| Security Menu | <ul style="list-style-type: none"> <li>• Set Supervisor Password</li> <li>• Password on boot</li> <li>• Power Management Security</li> <li>• Diskette access</li> <li>• Fixed disk boot sector</li> </ul> |
| Exit Menu     | <ul style="list-style-type: none"> <li>• Load Setup Defaults</li> <li>• Discard Changes</li> </ul>  |

and cannot get default value with F9 key.

## When the system starts or resumes from Hibernation

If you have enabled Password on boot in the Security menu of the Setup Utility, the system requires a password when you turn on the computer. If you have enabled Power Management Security, the system requires a password when the system resumes from Hibernation.



The person who does not know the supervisor password cannot read/write a floppy disk when the item of Diskette access is defined as Supervisor in the Security menu of the Setup Utility.

## Setting the Password

1. In the Security menu of the Setup Utility, select Set Supervisor Password or Set User Password and press Enter.
2. Type your password (up to eight characters), and press Enter.
3. Type the same password again, and press Enter.
4. When the confirmation message appears, press Enter.
5. Press Esc and select Exit Saving Changes.
6. Press Enter twice. The system restarts and asks the password you have set.

## If you use the computer personally

We recommend that you set the supervisor password. You can prevent other people from using your computer by enabling Password on boot in the Security menu of the Setup Utility.

## If you share the computer with others

We recommend that a person who administers the computer sets both supervisor and user passwords and lets the other people know only the user password.

## Changing the Password

1. In the Security menu of the Setup Utility, select the password item you want to change and press Enter.
2. Type your current password, and press Enter.
3. Type your new password, and press Enter.
4. Type your new password again, and press Enter.
5. When the confirmation message appears, press Enter.
6. Press Esc and select Exit Saving Changes.
7. Press Enter twice. The system restarts.

## Deleting the Password

1. In the Security menu of the Setup Utility, select the password item you want to delete and press Enter.
2. Type your current password, and press Enter.
3. Without typing any characters, press Enter.
4. Press Enter again.
5. When the confirmation message appears, press Enter.
6. Press Esc and select Exit Saving Changes.
7. Press Enter twice. The system restarts.

## Preventing Infection of Computer Viruses

You can protect against some viruses by limiting writing to the hard disk. To limit writing to the hard disk, set the item Fixed disk boot sector to Write Protect in the Security menu of the Setup Utility.



- You cannot prevent infection of all types of viruses with the above operation.
- Even if a warning message appears, the system may not be infected in some cases.

## Setup Utility

This chapter describes how to run the Setup Utility to change settings on your computer.

## Running the Setup Utility

With the Setup Utility, you can customize the system configuration information, such as time and date, port assignments, passwords, or power management settings. The information you have specified is saved in a special area called CMOS RAM, which the system reads every time you turn on the computer.

## Contents of the Setup Utility

The Setup Utility consists of five menu pages, as follows:

- Main: Basic system configuration
- Advanced: Device interface configuration (I/O ports, etc.)
- Security: Password settings
- Power: Power management (battery saving settings)
- Exit: Exit the Setup Utility or return to the default values

## Entering and Exiting the Setup Utility

1. Turn on the computer.
2. When Press <F2> to enter SETUP appears, press F2.
3. Change the desired settings.
4. Press Esc to select the Exit menu.
5. Select one of the exit methods, and press Enter.
6. When the message Setup Confirmation appears, press Enter again. The system restarts.



To turn off the computer when the Setup Utility is open, press the power switch.

## Using the Setup Utility

To navigate through the different menus, you can use the following keys:



Moves the cursor from one menu to another.



Moves the cursor from one item to another in a menu.



Space bar

Increases the numeric value or changes an item to the next value.



Decreases the numeric value or changes an item to the previous value.



Enters the Exit menu. When a sub-menu is open, this key closes the sub-menu.



Replaces the settings on the current menu with their default values (date and time are not changed).



Saves the settings you have changed and exits the Setup Utility.



Displays online help for the Setup Utility.

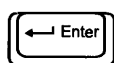

Displays sub-menu. Items with ► marks contain sub-menus.

## Main menu

**System Time** Defines the system time, using the format hour:minute:second (24-hour format). The Tab key moves the cursor, and the space bar and the "-" key change numerals.

**System Date** Defines the system date. The Tab key moves the cursor, and the space bar and the "-" key change numerals.

**Diskette A** Defines whether to use the floppy disk. To use it, set this item to 1.44MB, 3 1/2".

**Hard Disk Type** Specifies the hard disk type. Set to Auto during normal use.

**Boot Sequence** Specifies the sequence in which the boot program looks for operating system files.

**Internal Numlock** Defines whether you can input numerals through keys with blue legends on the built-in keyboard when you connect an external keyboard and lock its numeral keys.

**Memory Cache** Enables or disables the memory cache function that accelerates the access speed to data previously accessed.

**QuickBoot Mode** Enables or disables the quick boot function. When this item is enabled, the system skips certain tests while booting.

**Quiet Boot** Enables or disables the quiet boot function. When this item is enabled, the system shows SHARP logo screen while booting.

**BIOS version** Shows BIOS version of your notebook.

**EC version** Shows the version of power source firmware.

**System Memory** shows the size of conventional memory for starting MS-DOS.

**Extended Memory** Shows the size of extended memory with 1MB or larger.

## Advanced menu

**Serial Port** Sets the RS-232C serial port, selecting the base I/O address. Enabled means that you can select the item yourself. Auto means that the item is automatically assigned. Disabled means that you cannot use the port.

**IR Port** Sets the infrared port, selecting the mode, the I/O channel, the IRQ channel, and the DMA channel. Enabled means that you can select the items yourself. Auto means that all the items except the mode are automatically assigned. Disabled means that you cannot use the port. Set to Auto during normal use.

**Mode** Specifies the IR mode: IrDA or ASK. Set to IrDA during normal use.

**LPT Port** Sets the printer port, selecting the mode and the base I/O address. Enabled means that you can select the items yourself. Auto means that the base I/O address is automatically assigned. Disabled means that you cannot use the port.

**Mode** Specifies the LPT port mode: Bi-directional, Output Only, EPP (Enhanced Parallel Port mode) or ECP (Extended Capabilities Port mode).

**Internal Pointing Device** Enables or disables the glide pad.

**Resolution Expansion** Defines whether the screen is expanded when the resolution is 640 x 480 or 600 x 800. Enabled means that the screen is expanded.

**USB Port** Enables or disables the USB port. Always set to Enabled; otherwise, some PC cards may malfunction.

**LAN** Enables or disables the LAN port.

**Plug & Play O/S** Defines whether the operating system supports the plug & play function. Set to Yes during normal use.

**Large Disk Access Mode** Selects the operating system. Set to DOS during normal use. If you use another operating system such as UNIX, select Other.

**PCI Configuration** Defines IRQs for some internal devices. Leave them as default during normal use. Never set them to Disabled.

## Security menu



- See the previous chapter about setting passwords.
- In some password settings, you cannot select some items.

**Set Supervisor Password** Defines the supervisor password (up to eight characters).

**Set User Password** Defines the user password (up to eight characters). You cannot set the user password unless you have set the supervisor password.



If you lose your password, you will be unable to access the computer or change the configuration. Make sure to select a password you will never forget, or write it down and protect it in a secure place. Otherwise, you will have to contact your dealer for assistance.

**Password on boot** Defines whether the system requires passwords during the boot process. Enabled means that you need to input a password to continue.

**Power Management Security** Defines whether the system requires a password when it resumes from the suspend-to-disk mode. Enabled means that you need to input a password to continue.

**Diskette access** Specifies who can access the floppy disk drive.

**Fixed disk boot sector** Defines whether the boot sector of the hard disk is write-protected. When formatting the hard disk or when reinstalling software, set it to Normal.

## Power menu



- All items you set except for Auto Backlight Control do not work in Windows 98.

**Power Switch Function** Defines the function of the power switch. If you select On/Off, the switch works only to turn on/off the computer. If you select Suspend/Resume, the system enters the mode that is specified in the item Suspend Mode when you press the power switch. To resume the system, press the power switch again.

**Cover Close** Specifies the mode the system enters when the screen cover is closed.

**Power Management Function** Enables or disables the items below: Hard Disk Power Down after, Video Power Down after, and Auto Suspend.

**Hard Disk Power Down after** Defines the duration of non-access to

the hard disk after which the power supply for the hard disk stops automatically.

**Video Power Down after** Defines the duration of non-access to the screen after which the power supply for the screen stops automatically.

**Suspend Mode** Defines which mode the system enters when the system is suspended.

**Auto Suspend** Defines whether the system enters a suspend mode when you do not operate the computer for the specified length of time. This item does not function under Windows 98.

**Critical Battery Suspend** Defines whether the system enters the suspend-to-disk mode when the battery power becomes low.

**Auto Backlight Control** Enables or disables the self-adjustment of the display backlight. When this item is enabled, for example, backlight brightness is reduced when the system operates on battery power.

**Resume On Modem Ring** Defines whether the system resumes from Standby when the modem receives a call. (may not be available in some countries)



The built-in modem may not be available in some countries.

**Battery Level** Shows the amount of battery power remaining. Battery 1 refers to the standard battery; Battery 2 refers to the optional external battery pack.

## Exit menu

**Exit Saving Changes** Saves the settings you have changed and exits the Setup Utility.

**Exit Discarding Changes** Exits the Setup Utility without saving the settings you have changed.

**Load Setup Defaults** Returns the values of all items to default. To exit, select one of the above items.

**Discard Changes** Returns the values of all items to the values you last saved.

**Save Changes** Saves the settings you have changed.

# CHAPTER 2. SPECIFICATIONS

## 1. Specifications

Parts		Specifications
CPU		Mobile Pentium II Processor (frequency differs by configuration)
Secondary cache		256KB(Integrated with CPU)
ROM		Including system BIOS and VGA BIOS
RAM	System	SDRAM 64MB (expandable to 128MB)
	Video	2.5MB
Display	Panel	Active Matrix (TFT) color LCD
	Video controller	Trident Cyber
Keyboard		IBM compatible keyboard
Pointing device		Glide pad (touch-sensitive control pad with 2 buttons )
Drive	Hard disk	IDE interface
	Floppy disk (external)	3.5", 1.44MB/720KB
PC card slot		Type II x 1 (PCMCIA 2.1 compliant) CardBus compliant
Audio system		Monaural microphone, monaural speaker, sound system compliant with Sound Blaster Pro
I/O ports	Audio	Audio output jack, external microphone jack
	Video	External monitor port
	Others	Two USB ports, modem jack, LAN jack
	Others (on external floppy disk drive)	Parallel port, RS-232C serial port, keyboard/mouse port
Infrared		IR port (IrDA: 115Kbps/4Mbps, SHARP ASK: 9600bps)
Modem (may not be available in some countries)		Data: 56Kbps(receive), 33.6Kbps(send), Fax: 14.4Kbps
Power	AC adapter	100–240V, 50–60 Hz
	Battery	Rechargeable lithium ion battery
	Battery life	Approximately 2 hours (standard internal battery only) Approximately 4 hours (with flat panel battery (CE-BP01) connected) Approximately 6 hours (with external battery pack (CE-BL03) connected) *battery life varies depending on usage
	Battery charging time (both standard and optional external batteries)	Turned off/suspended to disk: about 5.5 hours Turned on: about 7.5 hours *charging time varies depending on usage
Dimensions	Computer	10.4" wide x 8.3" deep x 0.91"(min.)/1.22"(max.) high (263mm x 212mm x 23mm(min.)/31mm(max.))
	Floppy disk drive unit	4.65" wide x 6.81" deep x 0.94" high(118mm x 173mm x 24mm)
Operating environment	Temperature	50°F to 95°F (10°C to 35°C)
	Humidity	20% to 80% (non-condensation)

### Options (may not be available in some countries)

External Battery Pack	CE-BL03
Flat Panel Battery	CE-BP01
External CD-ROM Drive	CE-CD01
Optional AC Adapter	CE-J02V

## 2. Differences in specifications

Model name	PC-A290	←	←
Destination code	A3PCA290U	A3PCA290A	A3PCA290E
Country	U.S.A	Hong Kong	Australia, Singapore, and other countries

### Major specifications

CPU	Pentium II Processor 366 MHz	←	←
L2 cache	256KB BUILT IN CPU	←	←
Memory	64MB SDRAM (Max. 128MB)	←	←
Display	11.3" XGA TFT (AGAR)	←	←
HDD	9GB	←	←
FDD	External 3.5" 1.44MB/720KB	←	←
CD-ROM drive	Optional	←	←
Modem	56 kbps	←	None
LAN	100Base-TX / 10Base-T	←	←
PC card slot	Type II x 1 (Card Bus)	←	←
Key board	US	←	←
Pointing device	Glide pad	←	←
IR	ASK + IrDA (4Mbps)	←	←
OS	Windows 98 (English)	←	←

### OS / Software

HDI version	U	A	E
Windows 98	English	←	←
IE5.0	English	←	←
LapLink Pro	Yes	←	←
Sharp IR utility	English	←	←
Adobe Acrobat Reader 4.0	English	←	←
Navigator	None	←	←
Default wallpaper	ACTIUS ver.	SHARP ver.	←

**CPU**

- Intel Mobile Pentium II 366MHz
- Core Voltage : 1.6V, CPU CMOS : 1.8V, Signal interface : 2.5V
- 1st Cache : 32KB, 2nd Cache : 256KB
- 615pin BGA package

**System core logic**

- Intel 440DX PCiset
- North bridge (System Controller) : 82443DX, Host to PCI bridge and system memory. Core Voltage : 3.3V, 492pin BGA package
- South bridge (PCI to ISA/IDE Xcelerator) : 82371EB (PIIX4E), PCI to ISA bridge, controls IDE, USB and Power Management, Includes RTC. 3.3V (5V tolerance), 324pin BGA package

**System memory**

- Standard 64MB SDRAM
- 64M bits SDDRAM x 8, 3.3V
- Expanded 64MB SDRAM (Total 128MB)

**Clock Generator**

- ICS ICS9148-12
- Input 14.31813 MHz, Controlled via SM bus i/f
- Core Voltage : 3.3V, Output 3.3V & 2.5V, 28pin SSOP package

- Resolutions and Colors in the multiple displays

		640 x 480			800 x 600			1024 x 768			1280 x 1024
		256 colors	65,536 colors	16,770,000 colors	256 colors	65,536 colors	16,770,000 colors	256 colors	65,536 colors	16,770,000 colors	256 colors
640 x 480	256 colors	○	○	○	○	○	○	○	○	×	○
	65,536 colors	○	○	○	○	○	○	○	○	×	○
	16,770,000 colors	○	○	○	○	○	×	○	×	×	○
800 x 600	256 colors	○	○	○	○	○	○	○	○	×	○
	65,536 colors	○	○	○	○	○	×	○	○	×	○
	16,770,000 colors	○	○	×	○	×	×	×	×	×	×
1024 x 768	256 colors	○	○	○	○	○	×	○	○	×	○
	65,536 colors	○	○	×	○	○	×	○	×	×	×
	16,770,000 colors	×	×	×	×	×	×	×	×	×	×

**Video Controller**

- Trident Cyber9525DVD
- Includes 2.5MB VRAM, System i/f : PCI, LCD i/f : LVDS
- Resolutions and Colors

Resolution	Number of Colors
640 x 480	256 64K 16M (*1)
800 x 600	256 64K 16M (*1)
1024 x 768	256 64K 16M (*1)

\*1: The number of colors in this mode is made using a Dithering algorithm (on the internal LCD only).

**LCD**

- Sharp LQ113X1LR10, 11.3" XGA AGAR-GRP TFT LCD with 1CCFT backlight
- Resolution : 1024 x 768
- Effective viewing area (H x V) : 230.4 x 172.8 mm
- Pixel pitch : 0.225 x 0.225 mm
- Power source : 3.3V, 5V, 12V
- I/F : LVDS

**LVDS Controller**

- NS DS90C363MTD
- 3.3V, 48pin SSOP package

**PCMCIA Controller**

- Ricoh RL5C475A rev.0
- 1 slot PCMCIA Controller, Supports 16bit card, Card bus card, ZB port.
- 3.3V, 144pin LQFP package
- Power Switch : Micrel MIC2562A-1BM (3.3V, 5V, 12V, 14pin SOP package)

**HDD**

- Fujitsu 2.5" 9GB HDD MHK2090AT
- 5V i/f, 9.5mm H

**BIOS**

- ATMEL AT29F040 4Mbits Flash EEPROM
- Includes System, Video, PnP and APM, ACPI.
- 5V, 32pin PLCC package

**Keyboard Controller**

- Mitsubishi M38813
- Support 2 PS/2 ports and 1 Touch pad.
- 5V, 64pin TQFP package

**Keyboard**

- Sejin 81 keys keyboard for US, 82 keys for Europe
- IBM 101/102 keys compatible keyboard
- Supports 2 windows keys
- 17mm pitch, 2.5mm stroke

**Touch Pad**

- Alps Glide pad
- PS/2 mouse compatible
- 2 click buttons
- Resolution (X x Y) :  $290 \pm 30 \times 255 \pm 30$  cpi
- Supports IntelliMouse scroll function.
- Automatically disabled when external mouse is connected.

**I/O controller**

- NS PC97338VJG
- Controls Serial port, Parallel port, IR port and FDD.
- 5V, 100pin TQFP package

**RS232C driver/Receiver**

- Harris HIS213
- 5V, 28pin TSOP package

**FDD**

- Mitsubishi 3.5" FDD MF355H
- 5V i/f

**Audio Controller**

- ESS ES1946
- Sound Blaster, Sound Blaster Pro, Windows Sound System compatible
- Full duplex operation
- PCI i/f
- 5V, 100pin TQFP package

**Modem Controller****(may not be available in some countries)**

- Pctel Software Modem PCT789T
- Supports K56Flex, V90
- PCI i/f
- 5V, 100pin TQFP package
- CODEC & DAA: Pctel PCT303D/PCT303W, 5V 16pin SOP package x 2

**LAN Controller**

- Realtek RTL8139AL
- Supports 10Base-T, 100Base-TX
- 5V PCI i/f (3.3V/5V exchanged by Bus switch)
- 5V, 128pin LQFP package

**Embedded Controller**

- Hitachi 1chip micro controller H8
- Controls Power Sequence, Battery Charge, SM bus for Battery Gage.
- 5V, 100pin TQFP

**DC/DC Controller**

- 5V, 3.3V : Maxim MAX786CAI, VAB(Battery or AC adapter), 28pin SSOP
- VCPUCORE(1.6V) : Toyota SB3030, 5V, 20pin TSOP
- VPP(12V) : Linear Tech. LT1301, 5V, 8pin SOP

**Regulator**

- VCPUIO(2.5V) : Sharp PQ2TZ15, 3.3V, 6pin
- VCPUCMOS(1.8V) : Trex XC62FP1802M, 3pin
- VMCU(4.7V) : NS LP2951CM, VAB, 8pin SOP
- VRTC(3.1V) : Trex XC62FP3102M, VMCU, 3pin

**Battery Charger**

- Linear Tech. LT1511
- 22V, 24pin SOP package

**Battery**

- Li-ion Battery
  - Internal : Panasonic 3.7V x 1550mAh x 4cells (4 series)
  - External : Panasonic 3.7V x 1500mAh x 8cells (4 series, 2 parallel)
- Battery Gauge : Benchmarq BQ2092
- Li-coin battery for CMOS backup : Hitachi Maxell CR2032, 3V 220mAh

\*) Danger of explosion if battery is incorrectly replace. Replace only with the same or equivalent type recommended by the manufacture. Discard used batteries according to the manufacture's instructions.

**AC adapter**

- SAMSUNG 22V 2.045A AC Adapter
- Input Voltage : 100-240VAC, Input Frequency : 50/60Hz

## CHAPTER 3. DISASSEMBLY AND REASSEMBLY

1. This section covers the disassembly procedure of the unit. Reassembly is made in the reverse order of disassembly.
2. Some parts that can be easily disassembled and reassembled may be omitted.
3. Before trying to disassemble the unit, make sure of the wiring and the positions of the tapes and Mylars used.
4. Take an appropriate antistatic measure, such as by using an earth band.

### 1. Removing main board

Remove the keyboard, upper cabinet, LCD unit and the main board from the lower cabinet, according to the flow chart.

Main unit

- 1 Remove the two screws (X2P+4S) from the back of the unit.
- 2 Remove the 11 screws (X2P+5S) from the bottom of the unit. (Refer to Fig. A.)
- 3 Remove the seven screws (X2P+8S) securing the keyboard and hinges from the bottom of the unit.
- 4 Remove the palm rest.
- 5 Remove the keyboard.
- 6 Remove the screw (X2P+4S) securing the memory mounting plate.
- 7 Remove the memory mounting plate.
- 8 Remove the upper cabinet. (Pay attention to the microphone.)
- 9 Remove the screw (X2P+2.8S) securing the indicator cover.
- 10 Remove the indicator cover.
- 11 Remove the two screws (with washers M2 x 4) securing the modem.
- 12 Remove the modem unit.
- 13 Disconnect the LCD cable.
- 14 Remove the screw (X2P+6S) securing the display unit. (Refer to Fig. B.)
- 15 Remove the three screws (X2P+5S) securing the display unit. (Refer to Fig. B.)
- 16 Remove the display unit and heat sink unit (H). (Refer to Fig. B.)
- 17 Remove the two USB caps.
- 18 Remove the LAN cap.
- 19 Remove the D-SUB connector cover.
- 20 Disconnect the cables from the glide pad.
- 21 Remove the two screws (X2P+2.8S) securing the HDD assembly.
- 22 Remove the glide pad assembly.
- 23 Disconnect the connector from the built-in battery. (Note: The built-in battery is secured on the bottom cabinet with double-sided adhesive tape.)
- 24 Disconnect the HDD FPC cable from the HDD.
- 25 Remove the HDD.
- 26 Remove the speaker.
- 27 Remove the coin-type battery.
- 28 Disconnect the IR FFC cable.
- 29 Remove the screw (with washer M2 x 4) securing the main board.
- 30 Remove the main board assembly.

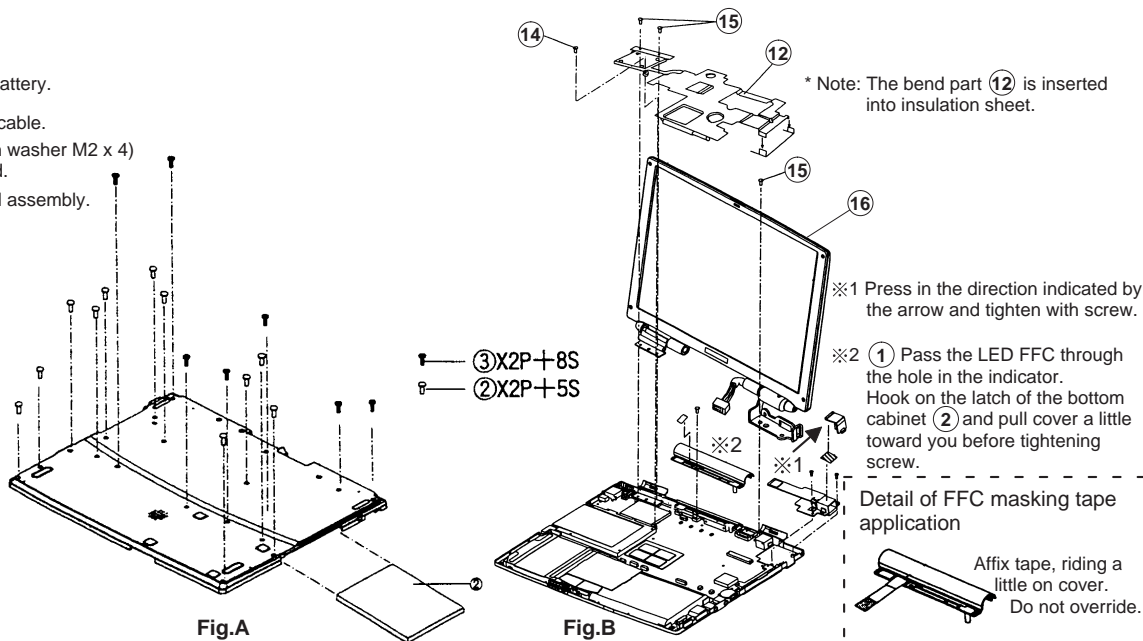
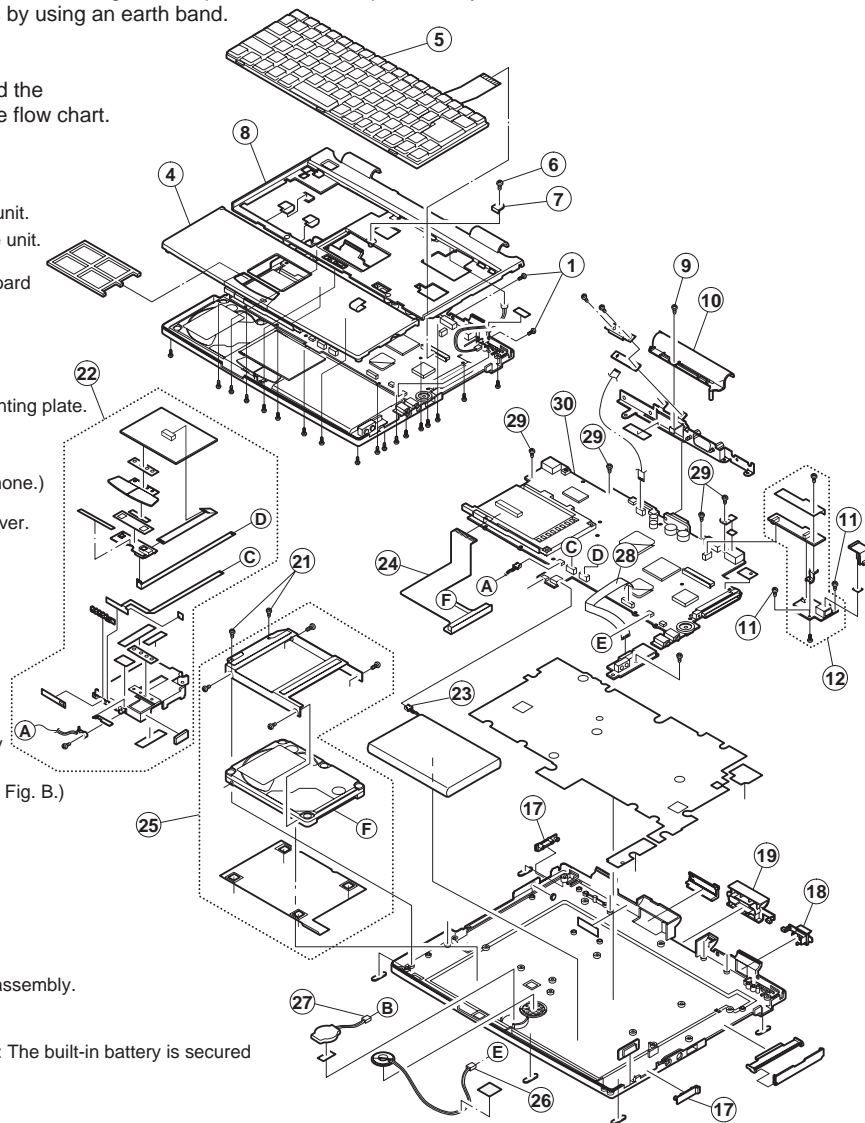

## 2. Removing LCD

Here is the procedure to be used after removing the display unit from the main unit.

Display unit

- ① Remove the hinge caps L and R. (Their parts codes are different.)
- ② Remove the four rubber caps.
- ③ Remove the two screws (X2P+2.8S).
- ④ Remove the screw (X2P+6S).
- ⑤ Remove the display mask.
- ⑥ Remove the three screws (X2P+6S) securing the hinges.
- ⑦ Remove the hinge L.
- ⑧ Remove the H/P hinge support angle.
- ⑨ Remove the LCD unit assembly.
- ⑩ Remove the inverter and LCD cable from the LCD unit assembly.

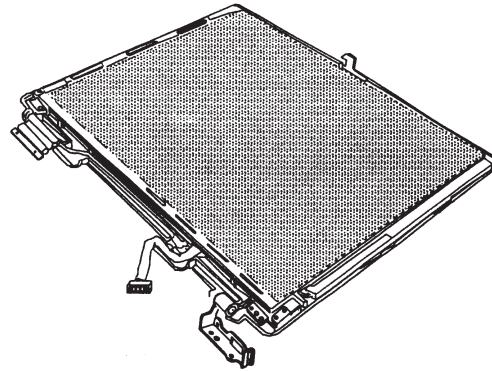
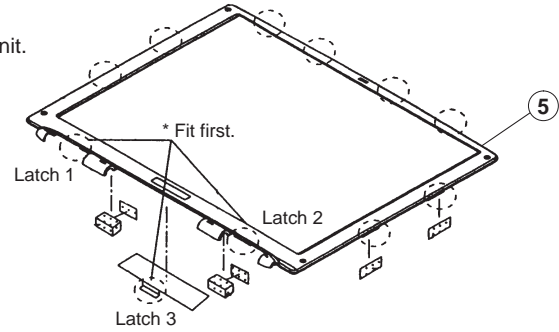

(Note)

1. Fit the three latches (1, 2 and 3) on the front side to the LCD cover unit assembly. (Use caution to prevent the inverter insulation sheet from getting caught.)
2. Then, fit in the clockwise direction.

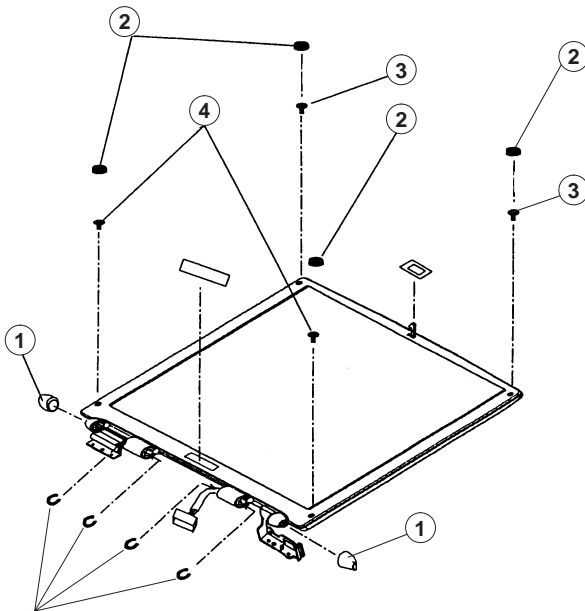

Attach to black washer spacer to the side of hinge.

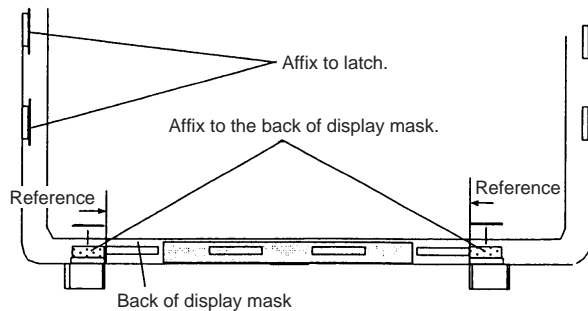
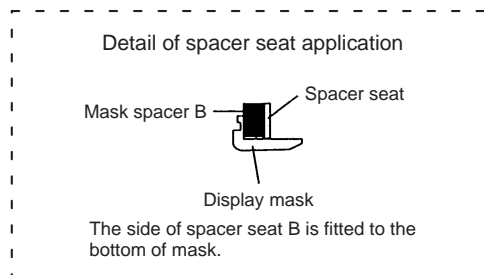
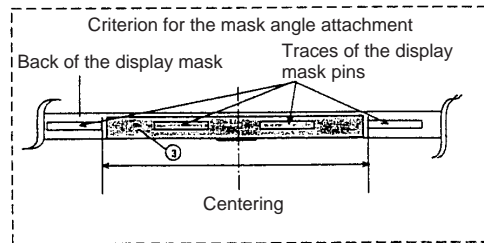
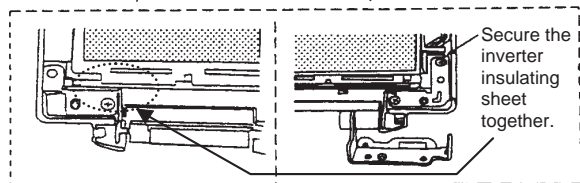
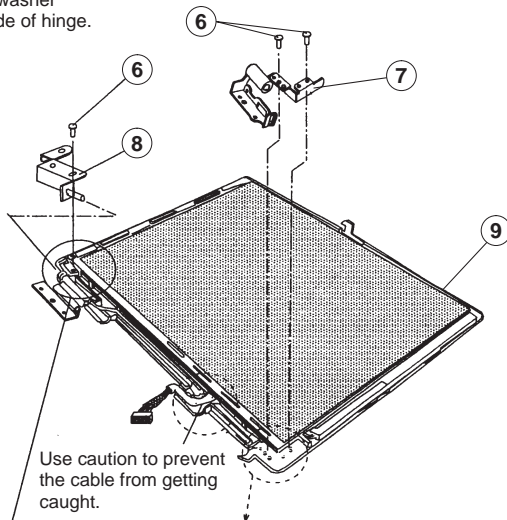

### 3. Cautions to be taken when reassembling

Here are cautions to be taken when reassembling the units and parts.

#### (1) Bottom cabinet

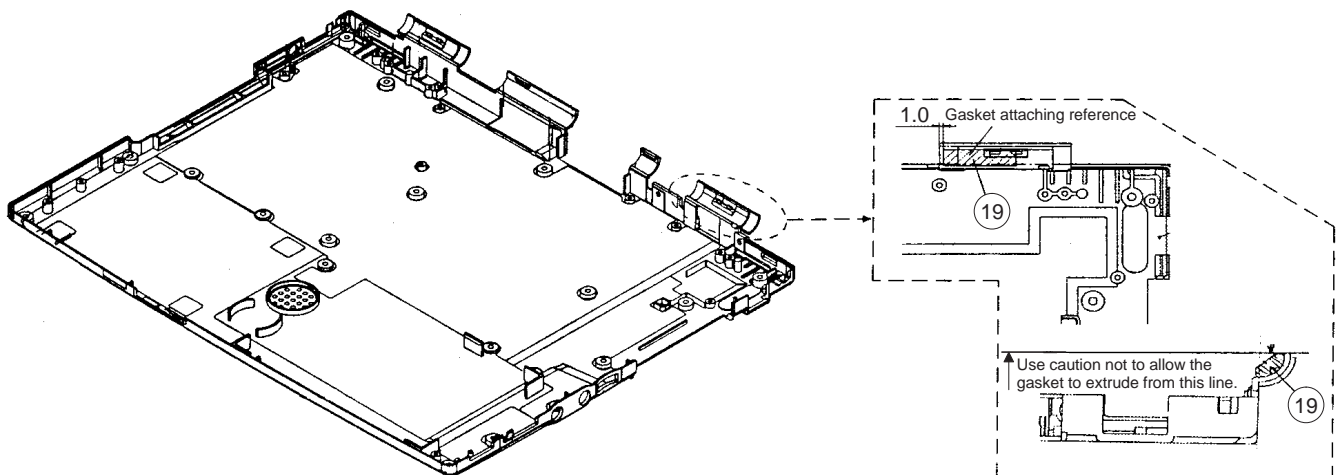
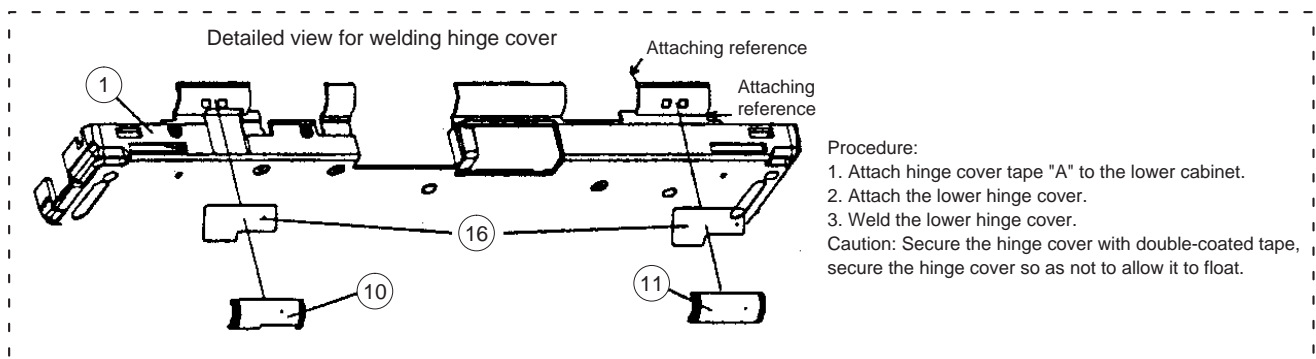
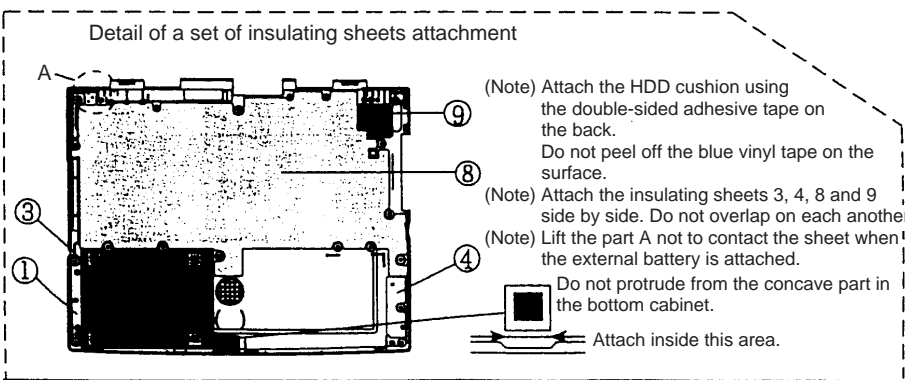
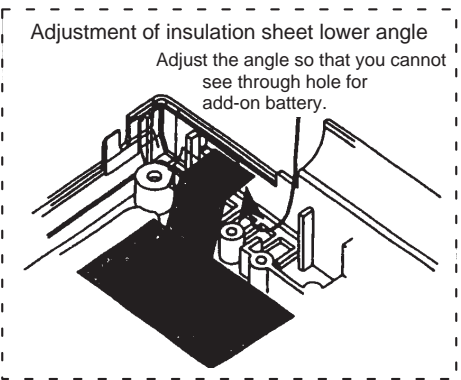
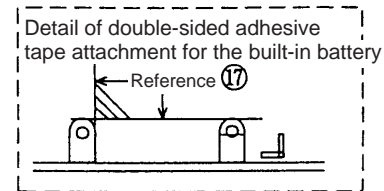
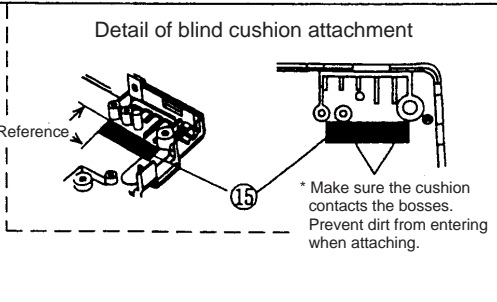
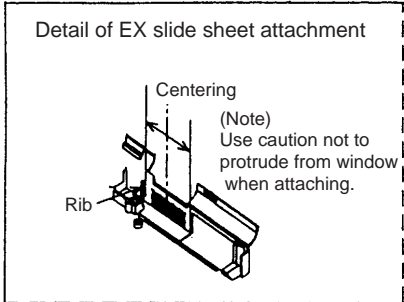

**(2) Main board unit**

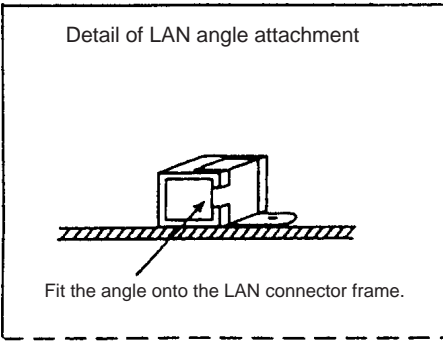

**Drawing of gasket attachment**

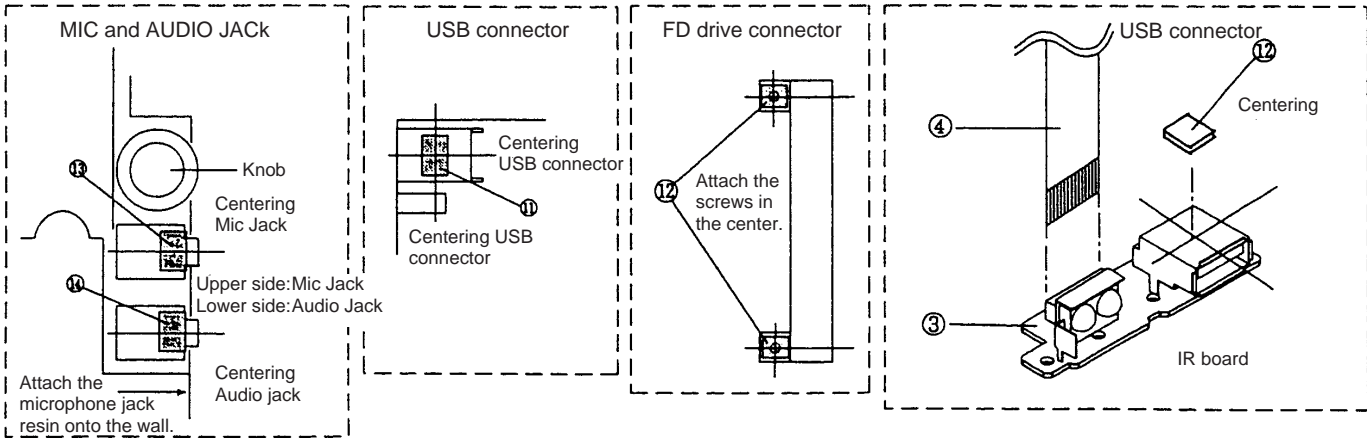

**(3) Coin-type battery and speaker**

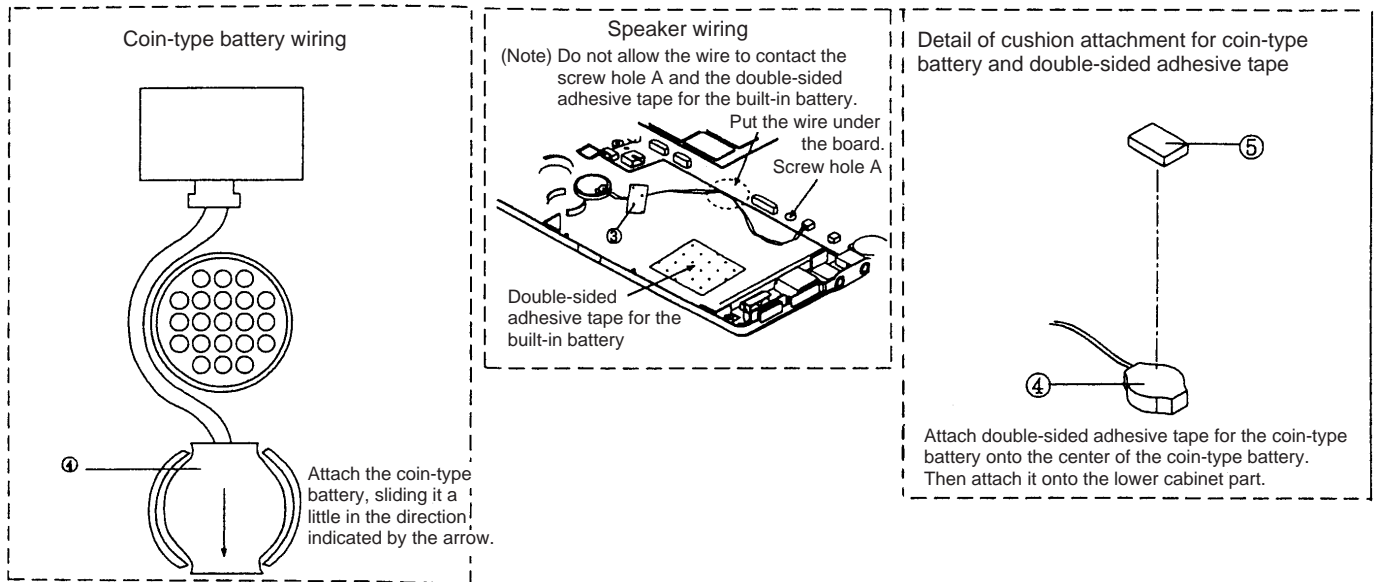

### (4) Insulation sheet and Thermal sheet

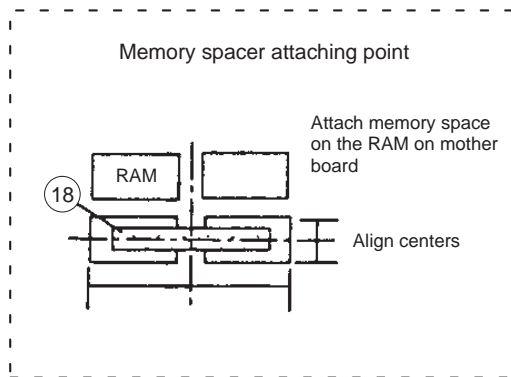
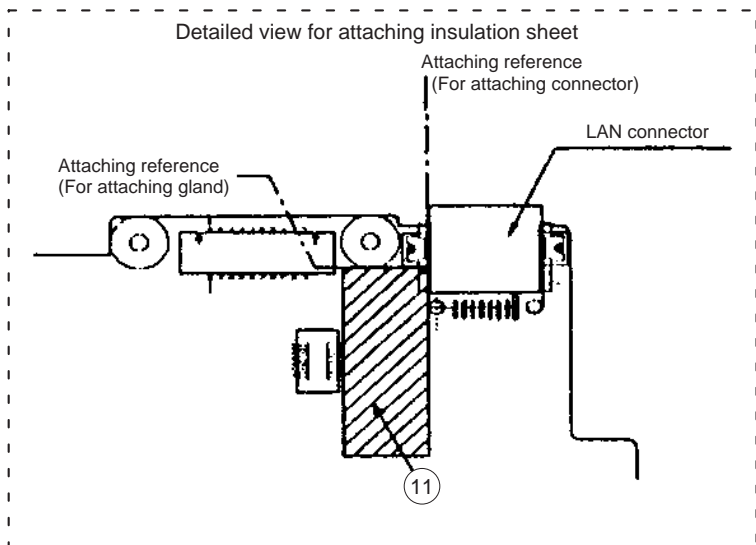
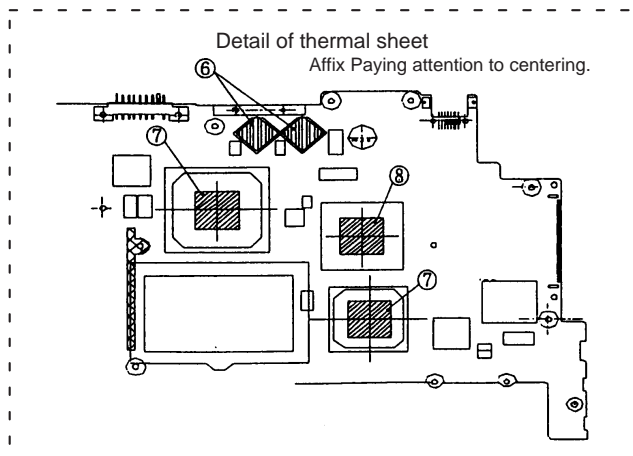
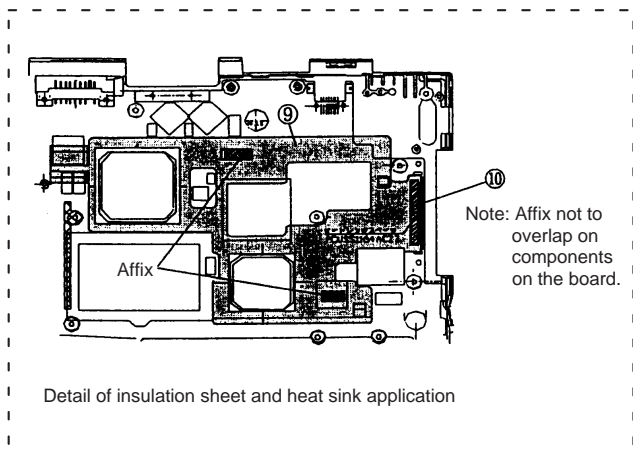

**(5) HDD chassis unit**

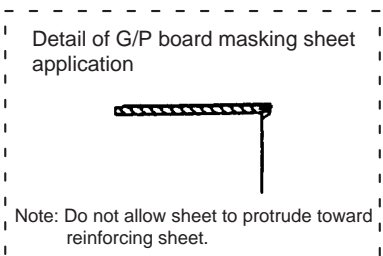
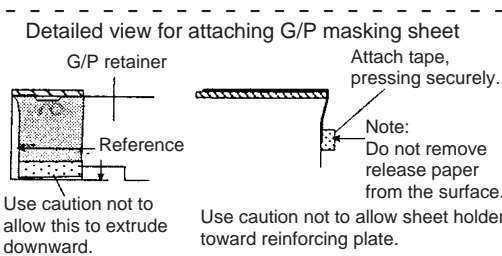
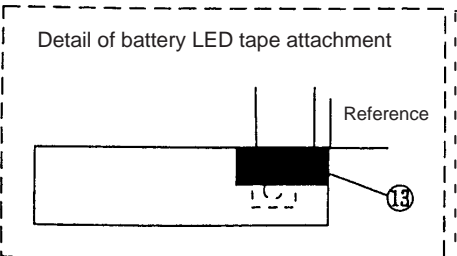
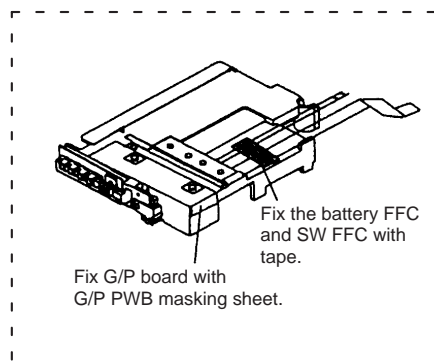
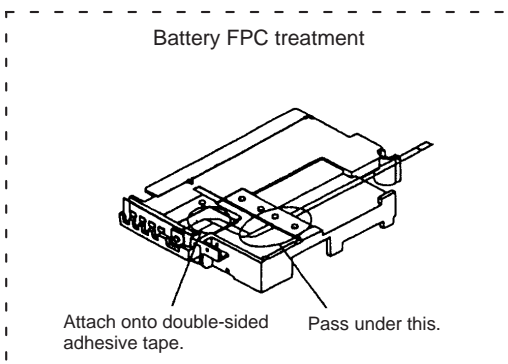
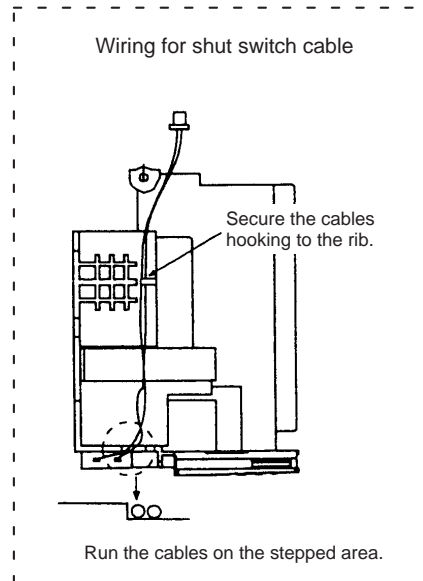
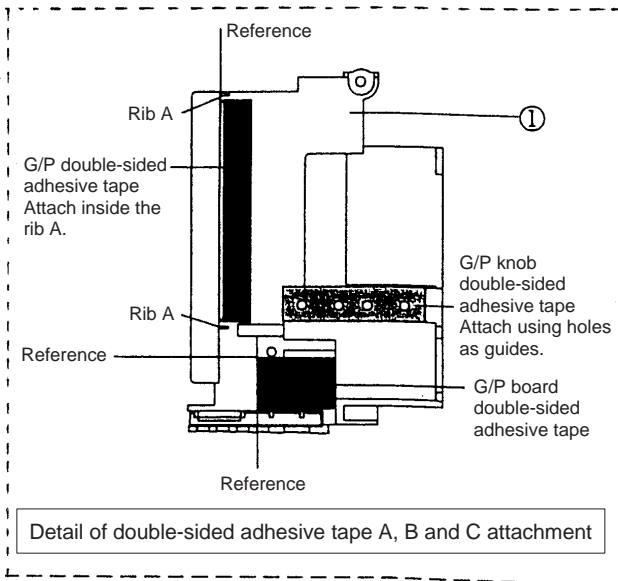

**(6) Battery unit**

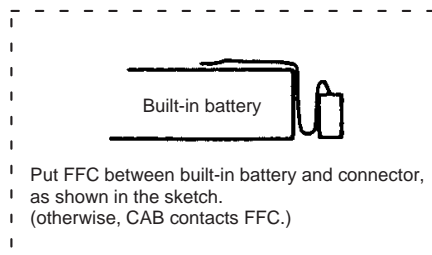
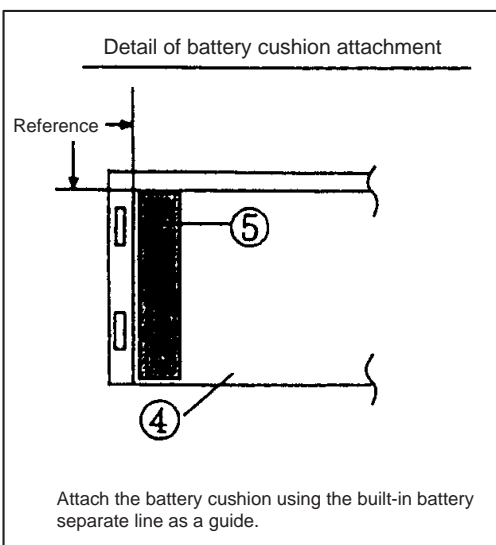

**(7) HDD unit**

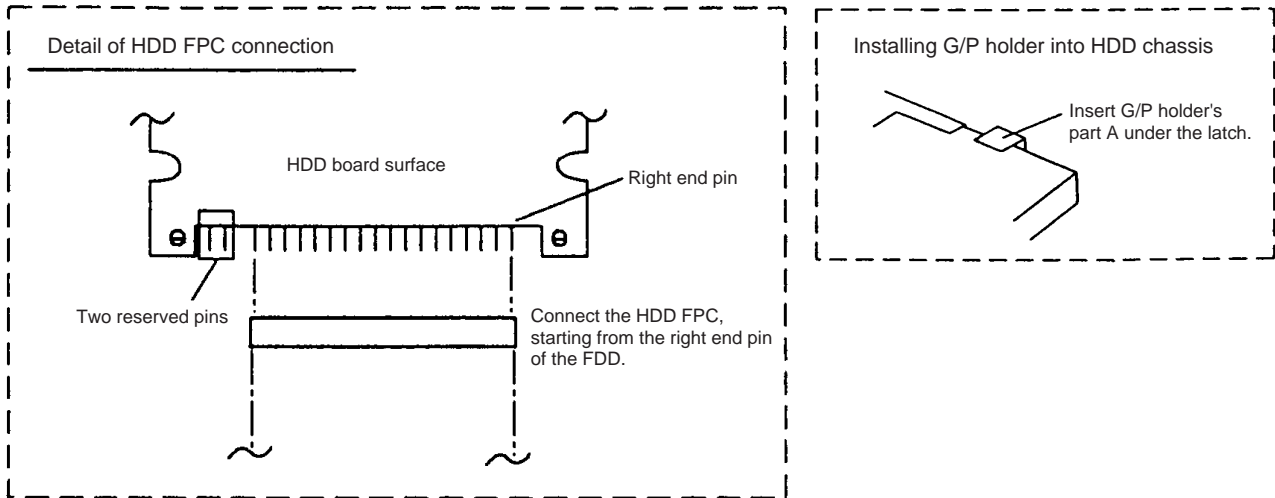

**(8) Microphone**

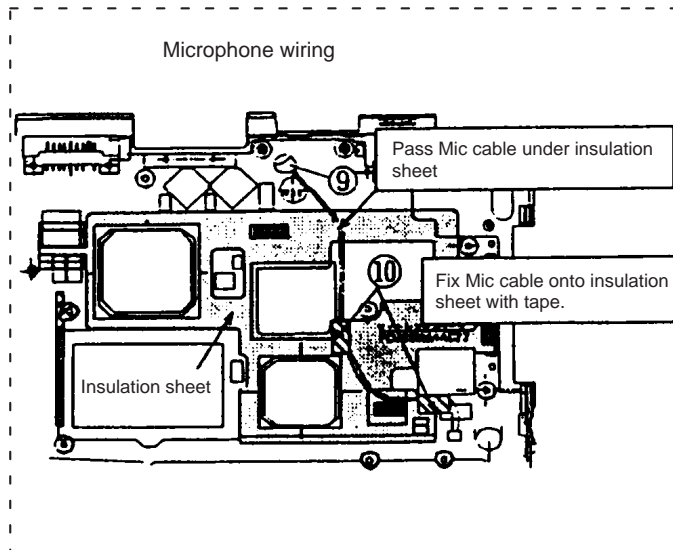

**(9) Detail of thermal sheet application**

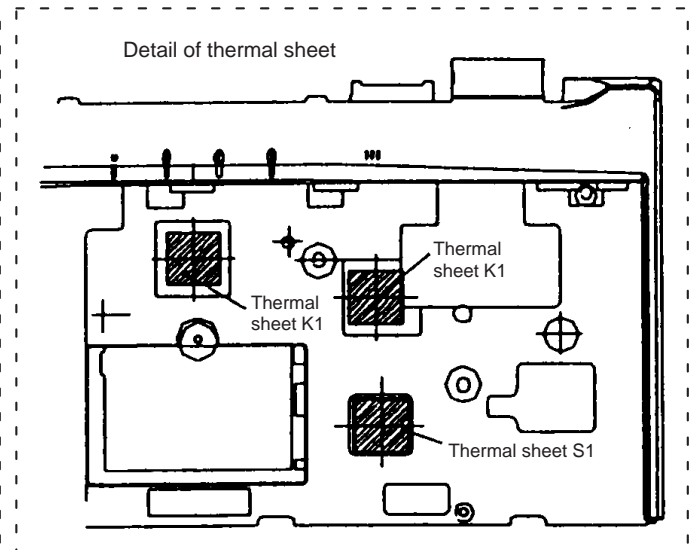

**(10) Palm rest cushion**

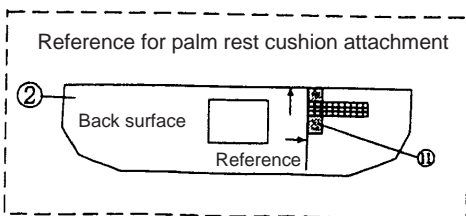

**(11) Indicator cover**

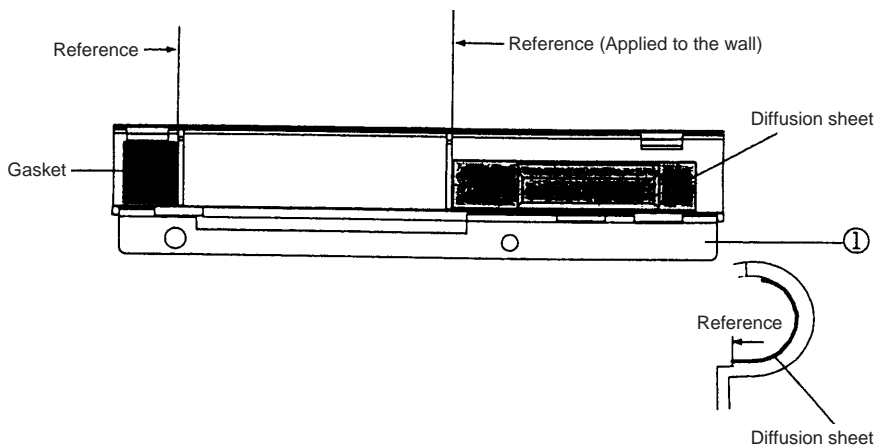

**(12) Display cover**

No.	Part names	Part code	Q'ty	No.	Part names	Part code	Q'ty
1	Display cover	GCABC1213ACZZ	1	8	Heat pipe hinge L	DUNTK5672ACZZ	1
2	Protection sheet	PSHEZ1282ACZZ	1	9	Boss spacer	PSPAZ2529ACZZ	6
3	Hinge cover 2R	GCOVA1185ACZZ	1	10	Hinge tape B	PTPEZ1196ACZZ	1
4	Hinge cover 2L	GCOVA1186ACZZ	1	11	Rib cushion	PCUSS1174ACZZ	2
5	Display lock button	JBTN-1050ACZA	1	13	Grease	—	—
6	Lock spring	MSPRC1060ACZZ	1	14	Thermal sheet	PSHEZ1256ACZZ	1
7	Locking polyethylene slider	LX-WZ1009ACZZ	1				

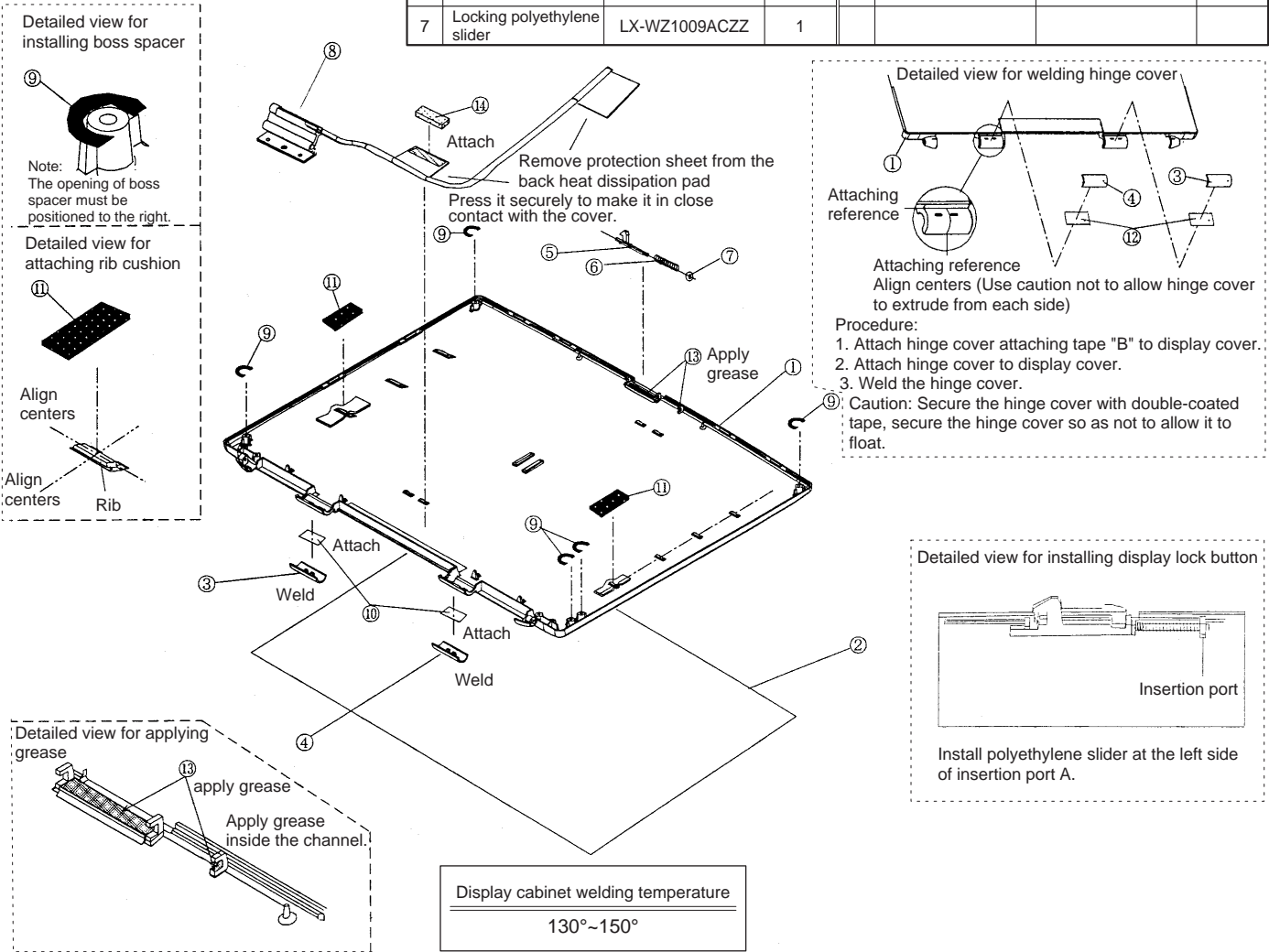

**(13) Inverter insulation sheet holding tape**

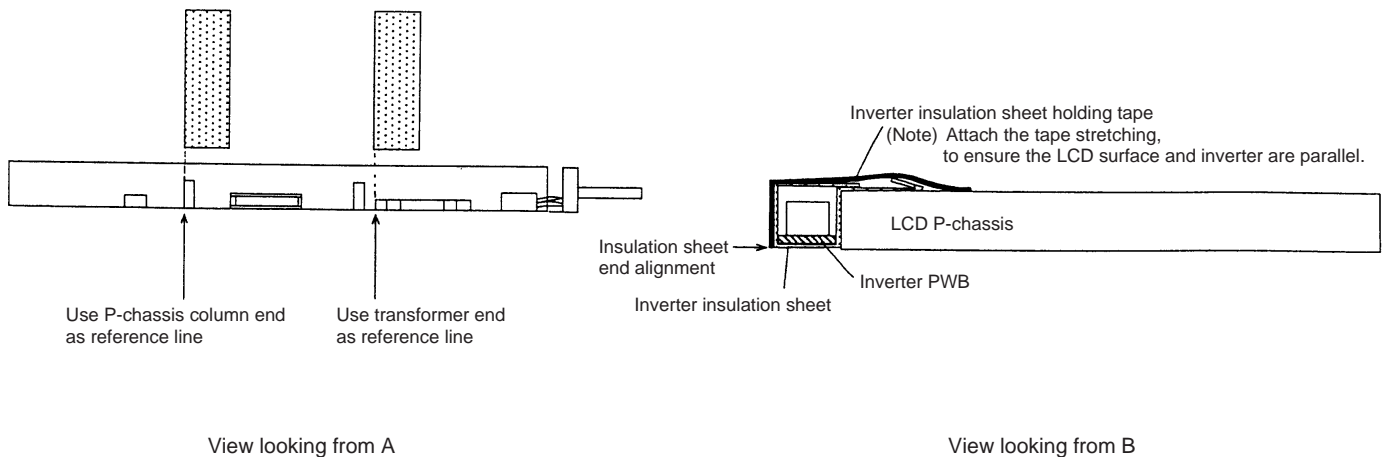

(14) Display unit

No.	Part names	Part code	Q'ty
1	Inverter unit	DUNTK5265ACZZ	1
2	Inverter trans-spacer	PSHEZ1255ACZZ	2
3	Inverter insulation sheet	PSHEZ1302ACZZ	1
4	LCD unit	VVLQ113S1LS22	1
5	LCD cable	QCNW-1480ACZZ	1
6	Cable fixing tape (conductive)	PTPEZ1141ACZZ	3
7	Cushion A	PCUSS1175ACZZ	2
8	LCD insulation sheet	PSHEZ1265ACZZ	1
9	Inverter cushion	PCUSS1172ACZZ	1

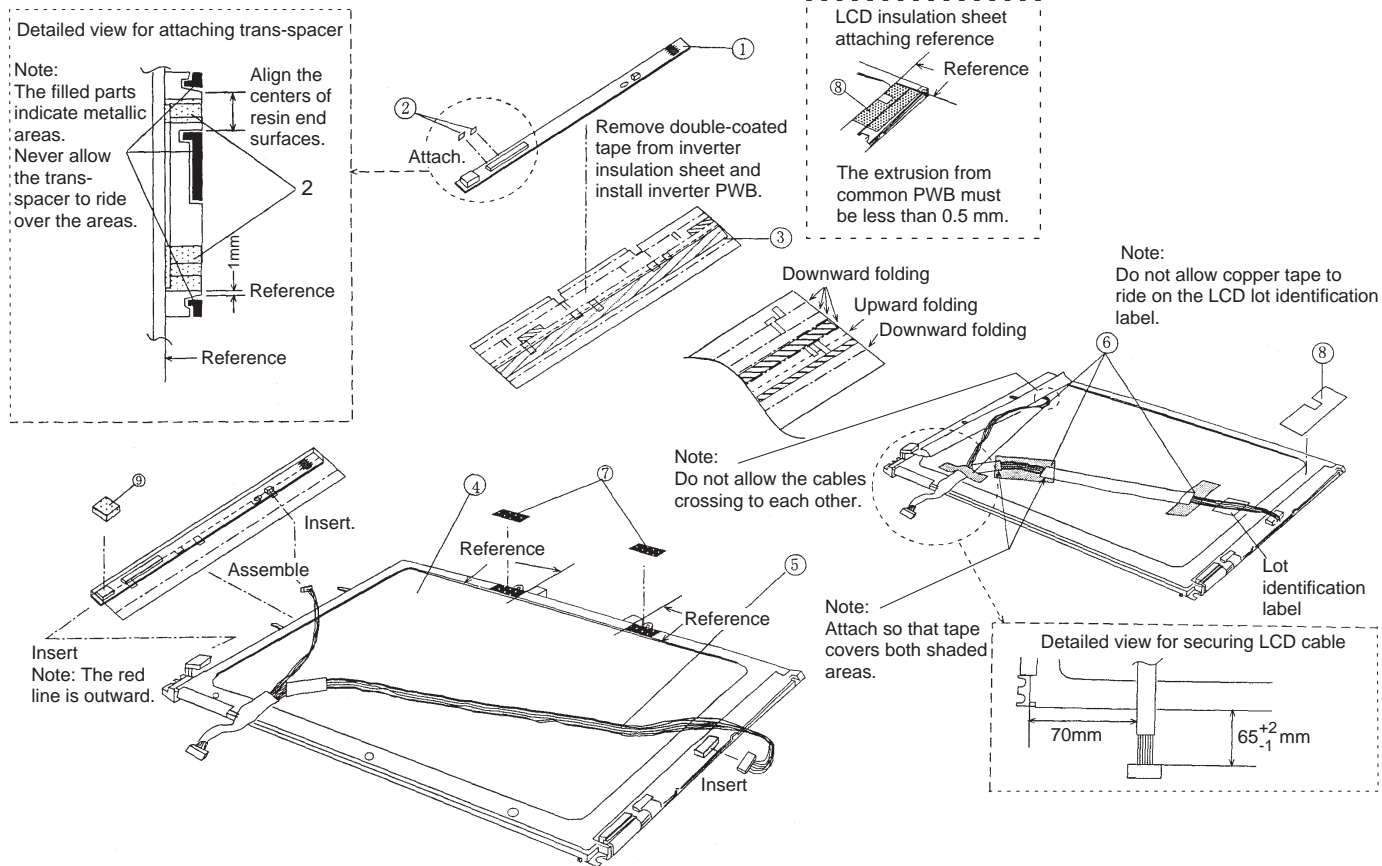

(15) Upper cabinet assembly

No.	Part names	Part code	Q'ty
1	Conductive cloth (long)	PTPEZ1177ACZZ	1
2	Conductive cloth (short)	PTPEZ1176ACZZ	3
3	Cushion	PCUSS1148ACZZ	1
4	Upper cabinet black label	PSPA2412ACZZ	1
5	Upper cabinet assembly	CCABB1185AC02	1
6	Gasket	PCUSS1152ACZZ	1

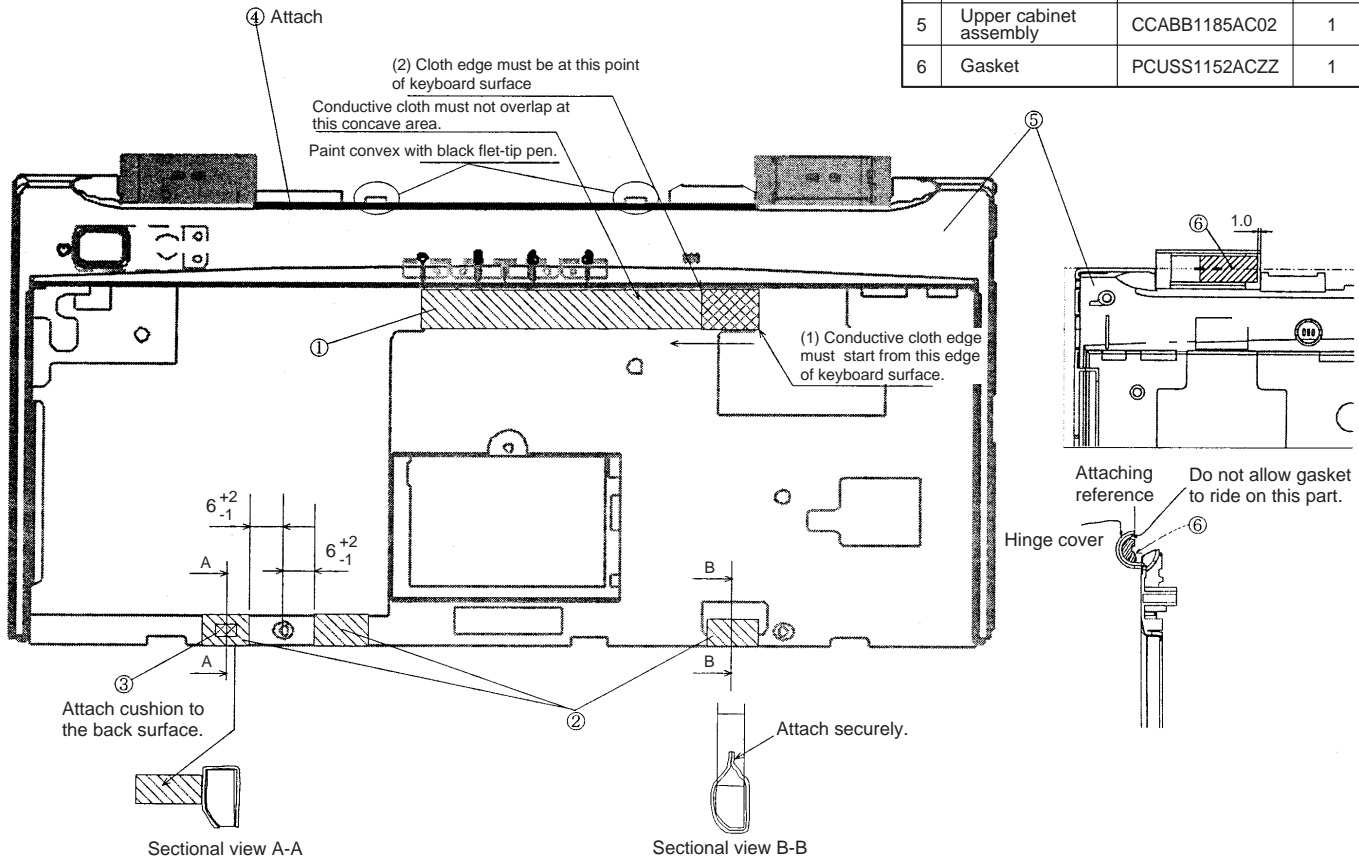

## CHAPTER 4. PRECAUTIONS

### FDD/HDD/CD-ROM

#### (Precautions when unpacking the package)

1. Be careful not to expose unit to any physical shock since it is a precision instrument. (do not give it a shock equivalent to or exceeding a drop from the height of 7.0 cm in a packed condition)
2. Be sure workers and their cloths are not charged with electricity when they handle the parts. (be sure they wear a grounding band)
3. Packing must be done under the following conditions: (same conditions apply to the assembling)

Temperature (°C)	Humidity (% RH)	Temperature change (°C/H)
10 ~ 40	20 ~ 80	20

\* When the temperature is low, do not forget to take measures against static electricity.

\* Temperature change means the difference in temperature between before and after the unpacking.

4. Be sure not to pile up precision instruments by themselves but to place each of them on a stable and non-shocking underlay. (be sure to keep the board surface down)

#### (Storage)

##### ◆ Storage method common in servicing and in packed condition

1. Be sure to store it in the following conditions:

Temperature (°C)	Humidity (% RH)
-16 ~ 60	20 ~ 80

\* Do not store in a car in summer.

\* When the temperature is low, do not forget to take measures against static electricity.

##### ◆ Storage method in servicing

1. When parts are stored alone, they should be covered. (be sure to take measures against dust)
2. Be sure to take measures against static electricity. (Place the part on a mat which prevent static electricity)
3. Do not pile up the parts. (also be sure not place any other part on a part)

##### ◆ Storage method in packed condition

1. Regardless the length of the storage period, store it in the same condition as it is originally packed and delivered.

#### (Handling)

1. Do not forget to wear a grounding band when working on unit.

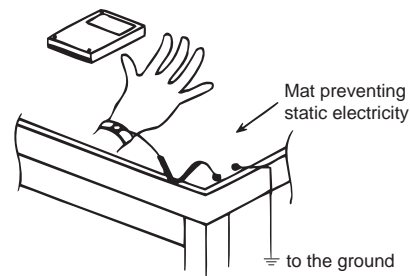

\* Confirm with a tester when you put the grounding band (1MΩ ~ 10MΩ) on. A grounding wire should be installed at an appropriate location.

2. For any unit, do not stack in piles.

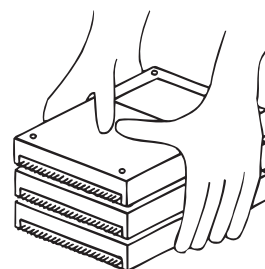

3. Avoid any impact with the unit.

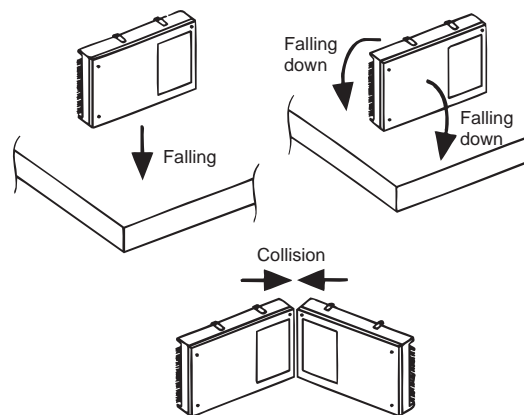

\* Be sure not to use the unit(s) if they were subject to any physical shock.

4. Hold the units by the side.

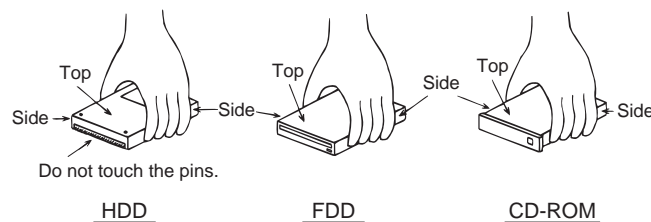

5. Use designated torque/tools (low impact drivers)
6. Keep magnetic materials away from the unit.

### Precaution when handling FDD

1. Do not press the top surface of FDD.

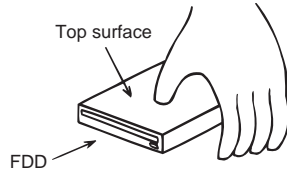

### Precautions when handling CD-ROM drive

1. Be sure not to touch the object lens.
2. Be sure to keep dust and dirt away from the object lens.

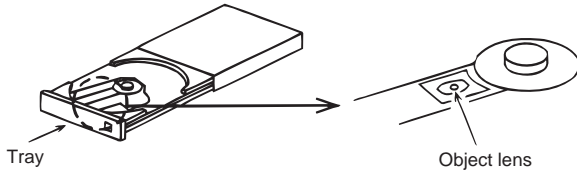

\* If the object lens is stained with dust and/or dirt, remove them with one of the following methods:

- Blow the dust with an airgun.
- Use Hitachi-Maxell's CD-ROM lens cleaner.
- Wipe the lens gently with an applicator using Nippon Applicators' CD lens cleaner liquid B4.

3. Do not press the top surface of CD-RM drive.

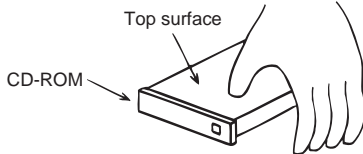

4. Do not pull the tray by force.
5. Do not apply any upward, downward, leftward or rightward force to the tray.
6. Be sure to insert a CD-ROM by pressing it in the middle.

### Precaution on HDD

1. Cable connection/disconnection and transfer of HDD shall be performed after the unit is left untouched for more than 15 seconds after the power supply is turned off (a state where the motor of HDD has been stopped or green/red light has been on).

## CHAPTER 5. RE-INSTALLATION

### Preparation for Re-installation

You can format the hard disk and re-install the preinstalled software with the recovery CD-ROM, and set the status of your computer to the same configuration as shipped from the factory. Necessary for re-installation are the following:

- Optional external CD-ROM drive (SHARP CE-CD01)
- Product Recovery CD-ROM
- Floppy disks or other external media for data backup
- Getting Started Microsoft Windows 98 manual

Unless otherwise specified, the instructions in this booklet assume that you use SHARP CE-CD01 CD-ROM drive.



- It will take about 30 minutes to complete the re-installation. The time depends on the data transfer rate of the CD-ROM drive.
- It takes about five seconds for the system to recognize a CD-ROM. If you operate too quickly, an error message may appear. In this case, return to the first step and repeat the installation.
- Use the Product Recovery CD-ROM only for your computer.
- Unless otherwise specified, the instructions in this booklet assume that you are installing Windows 98 into the C:\WINDOWS directory.



In the re-installation procedures, use only AC power. If you use the battery and the battery power becomes low, you cannot continue the re-installation.

### Backing up the data

Before formatting the hard disk, you should back up your data. For details on how to back up your data, see the Windows Online Help.



Although the pointer may be shown on the screen, never touch the keyboard or the glide pad during recovery except when the message prompts you to.

### Formatting the hard disk and reinstalling Windows 98 and other programs

1. If any peripheral devices, except the external floppy disk drive and the CD-ROM drive, are connected to your computer, disconnect them. See Chapter 4 of the Operation Manual.
2. Connect the external CD-ROM drive to the computer and turn it on.
3. Turn on the computer.
4. When the message Press <F2> to enter Setup appears, press F2. The Setup Utility opens.
5. Insert the Product Recovery CD-ROM into the CD-ROM drive.
6. In the Exit menu, select Load Setup Defaults; then, press Enter twice.
7. Set the items in each menu as follows:
  - Main
    - Boot Sequence: Set 1 to Option CD-ROM Drive
  - Power
    - Power Management Function Disabled
8. Press Esc; then, Enter twice. The system restarts.
9. Read the message and press Enter.
10. Follow the instruction on the screen.
11. After the hard disk is recovered, remove the Product Recovery CD-ROM and press any key. The system restarts.
12. Set up Windows 98, following the instructions on the screen.
13. After the setup is completed, select Shut Down.... from the Start menu.
14. In the Shut Down Windows dialog box, select Restart; then, Yes. The system restarts.
15. When the message Press <F2> to enter Setup appears, press F2. The Setup Utility opens.
16. In the Exit menu, select Load Setup Defaults; then, press Enter twice.
17. Make sure the item Exit Saving Changes is highlighted and press Enter twice. The system restarts, and recovery is completed.

## CHAPTER 6. DIAGNOSTICS

The production diagnostics is used as the service diagnostics for this model.

Note that some items cannot be diagnosed without proper jigs.

### 1. Scope

These specifications are used for testing the PC-A290 unit and checking the CE-BL03 charge.

### 2. Items to be tested

The following items are tested.

- Memory
- HDD
- Parallel port
- FDD (720KB/1.44MB/1.25MB)
- MCU version
- LCD
- LED
- Key board
- Glide point
- PS/2 port (Internal unit / FDD unit)
- Sound source
- Volume
- IR port
- Hard disk image
- LAN MAC address confirmation
- LAN testing (10BASE-T)
- RTC
- Serial port
- VRAM
- CPU clock
- PC card slot
- CRT output
- CPU temperature
- Internal microphone
- Speaker
- Suspend / shut switch
- USB port
- Internal modem

### 3. Testing tools

The following tools are required for testing.

- Boot disk for diagnostics
- Serial loop-back connector
- Parallel loop-back connector
- 3 FDs for testing (formatted for 720KB, 1.44MB and 1.25MB)
- Sycard
- CRT display
- Mouse (for PS/2 connection)
- Numeric keypad (for PS/2 connection)
- Y connector
- IR receive
- USB checker
- Hub cable for LAN testing

## 4. General procedure

The general procedure for testing is as follows:

Item	Checking and operating items
Operation	The operation is carried out by the person in charge. [ ] mean the key(s) that need to be pressed. If two pairs of brackets are written, like [Space][Enter], press the two keys in succession. If two keys are connected with the sign plus (+) like [Fn]+[F12], press the two keys simultaneously.
Confirmation	Items that must be confirmed by the person in charge. He confirms them and determines whether they pass or fail the test.
Description	Contents of tests and operations

### "STARTUP MENU" screen

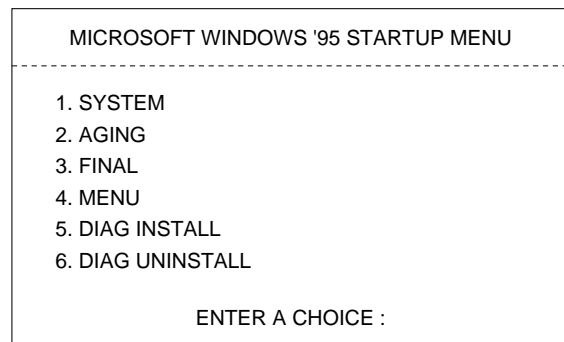

- (1) Insert the diagnostic starting disk into the FDD. Turn the power on to display "STARTUP MENU". Select the option "5. DIAG INSTALL" and install the diagnostic data into the HDD.
- (2) After the complete of the diagnostic installation, check the device you choose on the option "4. MENU" screen.
- (3) The model selection menu appears on the screen. Select the number of your model.

### MENU screen

MENU		
1. CPU CLOCK	11. PRINTER PORT	21. MIC
2. RTC	12. IR PORT	22. SUSPEND (RAM)
3. MCU VERSION	13. USB PORT	23. BATTERY
4. MEMORY	14. PCMCIA	24. IR RECEIVE
5. VRAM	15. LCD / CRT	25. LAN
6. HDD	16. LOCK KEY LED	26. Mac ADDRESS
7. FDD (720K)	17. KEYBOARD	27. CPU TEMPERATURE
8. FDD (1.44M)	18. TRNKEY /PS/2 PORT	28. MODEM
9. FDD (1.25M)	19. GLIDE POINT /PS/2 PORT	
10. SERIAL PORT	20. SOUND CHIP	

- (4) Erase the diagnostic program from the HDD after testing. Run the option "6. DIAG UNINSTALL" of "STARTUP MENU". The diagnostic program is erased from the HDD.

## 5. Contents of tests

The test procedures describe the content of the system test.

Select the option "4. MENU" of "STARTUP MENU" when the test items are checked respectively.

### System test (including installation)

No.	Item	Operation (The word inside the parentheses is the key to be pressed.)	Confirmation / display	Description
1	Preparation	Connect serial loop-back connector	—	
		Connect parallel loop-back connector	—	
		(When FDD unit is not installed) Install FDD unit.	—	
		Connect keyboard (numeric keypad) and PS2 mouse to PS/2 port on FDD unit.	—	
2	Power ON	[Power supply]	Check the boot disk in the FDD.	
3	Set BIOS	[F2]	Press any key while the [SHARP] logo is being displayed.	
		[Esc] [↓] [↓] [Enter] [Enter]	Load Set Defaults	Read standard settings
		[→]	Main	Display [Main] menu
		[(Present time)] [Tab] [(Present hour, minute)] [↓]	(Example) [11 : 22 : 33]	Set present time
		[(Month)] [Tab] [(Day)] [(AD)]	(Example) [11 / 22 / 1997]	Set date
		[→]	[Advanced] menu	
		Press [Space] key twice on Serial.	Serial : [Auto]	Set serial port to Auto
		Press [Space] key on LAN.	LAN : [Enabled]	Enable LAN
		Press [Space] key on Plug & Play OS.	Plug & Play OS : [No]	Set for non plug-and-play OS
		[→] [→] [↓] [Space]	Cover Close : [Suspend to RAM]	Set the shut switch operation for [Suspend (RAM)]
[↓] [Space]	Power Management Function : [Disabled]	Disable power management function		
(Reset)	[Esc] [Enter] [Enter]	Exit Saving Changes	Save settings and reboot	
4	Select test item/model machine	Select [System] from menu and press [Enter] Select the name of your machine in the menu and press [Enter]	—	To return to the menu, hold [CTRL] + [C] down simultaneously until the screen stops. Then press [Y], [1] and [Enter]
5	Install Diag (Confirm HD image.)	Confirm HD image and press [Enter]	Transfer Diag data from boot disk to HDD Confirm HD image After message "Install Complete" appears, it is finished	
6	Replace FDs	After making sure that FDD lamp goes out, remove the boot disk from FDD and insert test FD.	Make sure the test FD is formatted for 720KB	
7	Main memory (size)	Passed: no operation/Rejected failing: judgment [N]G / [R]etry	(Auto judgment)	
8	RTC	Passed: no operation/Rejected failing: judgment [N]G / [R]etry	(Auto judgment)	
9	HDD	Passed: no operation/Rejected failing: judgment [N]G / [R]etry	(Auto judgment)	
10	Serial port	Passed: no operation/Rejected failing: judgment [N]G / [R]etry	(Auto judgment)	
11	Parallel port	Passed: no operation/Rejected failing: judgment [N]G / [R]etry	(Auto judgment)	
12	VRAM	Passed: no operation/Rejected failing: judgment [N]G / [R]etry	(Auto judgment)	
13	FDD (720K)	Passed: no operation/Rejected failing: judgment [N]G / [R]etry	(Auto judgment)	If 720kB FD isn't inserted, the test is suspended displaying a message. Insert 720kB FD and press the space key.
14	CPU clock	Passed: no operation/Rejected failing: judgment [N]G / [R]etry	(Auto judgment)	
15	MCU version	Judgment [Y]es / [N]o	Make sure displayed MCU version is correct	
16	PC card slot	Insert the test card (Sycard) into the slot	—	
		[Space]	—	
		Passed: no operation / Rejected failing: judgment [N]G / [R]etry	(Auto judgment)	
17	LCD selection	Press [Space] ten times. Judgement [Y]es / [N]o / [R]etry	Turn on / off LCD to make sure the screen is normal.	

No.	Item	Operation (The word inside the parentheses is the key to be pressed.)	Confirmation / display	Description
18	LCD	After confirmation, press [Space].	Gradation (red): Make sure the gradation is smooth.	Press [Backspace] to go back screen
		After confirmation, press [Space].	Gradation (green): Make sure the gradation is smooth.	
		After confirmation, press [Space].	Gradation (blue): Make sure the gradation is smooth.	
		After confirmation, press [Space].	Gradation (white): Make sure the gradation is smooth.	
		After confirmation, press [Space].	Horizontal stripes 1: Make sure the stripe pattern is normal.	
		After confirmation, press [Space].	Horizontal stripes 2: Make sure the stripe pattern is normal. (the reverse video of the horizontal stripes 1)	
		After confirmation, press [Space].	Vertical stripes 1: Make sure the stripe pattern is normal.	
		After confirmation, press [Space].	Vertical stripes 2: Make sure the stripe pattern is normal. (the reverse video of the vertical stripes 1)	
		After confirmation, press [Space].	Black screen: Make sure the luminous points are located within the allowable range.	
		After confirmation, press [Space].	White screen: Make sure the dark points are located within the allowable range.	
		After confirmation, press [Space].	Wallpaper: Make sure the screen is free from flickers.	
		Judgment [Y]es / [N]o / [R]etry	—	
19	Lock key LED	Judgment [Y]es / [N]o	Check if [NumLock], [CapsLock] and [ScrollLock] LEDs come on / go out.	
20	Keyboard	Press all keys (except [Fn] keys).	(Auto judgment)	
		[Esc] [Esc] (If key-in is incomplete, operation is interrupted.)	—	
		Judgment [Y]es / [N]o / [R]etry	—	
21	Sound source (speaker / volume)	Switch over speakers by pressing the [Space] key.	Make sure the sound comes from internal speakers.	Switch over speakers to make sure both right and left signals are outputted from the internal speakers.
		Turn the volume knob to the full to pull it toward you.	Make sure no sound is heard when the volume is turned to MIN.	
		Turn the volume knob to the full to push it to the far end.	Make sure enough sound is heard when the volume is turned to MAX.	
		Judgment: [Y]es / [N]o	—	
22	Internal microphone	[Space]	Start recording	
		Voice input	—	
		[Space]	Start reproducing	
		—	Make sure the recorded sound is output properly.	If it is difficult to catch the sound, lift the unit slightly. (The speaker is installed at the bottom of the unit.)
		Judgement [Y]es / [N]o / [R]etry	—	
23	External microphone	Install external microphone	—	
		[Space]	Start recording	
		Voice input	—	
		[Space]	Start reproducing	
		—	Make sure the recorded sound is output properly.	If it is difficult to catch the sound, lift the unit slightly. (The speaker is installed at the bottom of the unit.)
		Judgement [Y]es / [N]o / [R]etry	—	
24	Glide point	Move the cursor.	Make sure the cursor moves smoothly.	
		Click the left button.	Make sure the left button is clicked to input commands.	
		Click the right button.	Make sure the right button is clicked to input commands.	
		Tap. (Tap the pad.)	Make sure the left button is clicked to input commands.	
	(PS/2 port)	Move the cursor (by PS/2 mouse).	Make sure the cursor moves smoothly.	
		Click the left button of PS/2 mouse.	Make sure the left button is clicked to input commands.	
		Click the right button of PS/2 mouse.	Make sure the right button is clicked to input commands.	
		Judgement [Y]es / [N]o	—	

No.	Item	Operation (The word inside the parentheses is the key to be pressed.)	Confirmation / display	Description
25	FDD unit PS/2 port  (Numeric keypad)	Enter [1] of the numeric keypad connected to PS/2 port.	(Auto judgment)	
		Passed: no operation / Rejected: judgment [N]G / [R]etry	—	
26	IR port (IrDA 1.0 115.2 K)	Point the IR port towards the IR port of the device you want to communicate.	—	
		[Space]	Execute testing (auto judgement)	
		Rejected: Terminate forcefully [Esc] / Judgement [N]G / [R]etry	—	
27	Connect LAN cable	Connect LAN cable		
28	Confirm LAN MAC address	Judgment [Y]es / [N]o	Make sure the address (the last 6 digits) are displayed correctly.	
29	Confirm LAN (IOBASE-T)	Passed: no operation / Rejected failing: judgment [N]G / [R]etry	—	
30	USB port	Connect the USB checker to the unit.	—	Check functions using "USB Host Production Tester (USB checker)"
		[Space]	Execute testing	
		After testing, [Space]	(auto judgement)	
		Passed: no operation / Rejected: judgement [N]G / [R]etry	—	
31	Connect modem connector	Passed: no operation / Rejected: judgement [N]G / [R]etry	(Auto judgment)	
32	Suspend (RAM) / shut switch	Close LCD	Make sure the LCD is suspended.	
		—	Make sure the power supply LED blinks.	
		Open LCD	Make sure the LCD returns to the state before it had been suspended.	
		Judgement [Y]es / [N]o	—	
33	Display results	—	Check if each test item has been passed/failed the test.	
		[Space]	Display the menu for individual checks.	
34	Power supply off	[Power supply]	Make sure the power supply is turned off.	
35	After testing	Remove the testing jig.	—	
		Remove the testing media.	—	

Serial loop-back connector wiring diagram

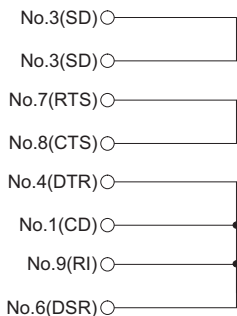

9 pin D-SUB connector

Parallel loop-back connector wiring diagram

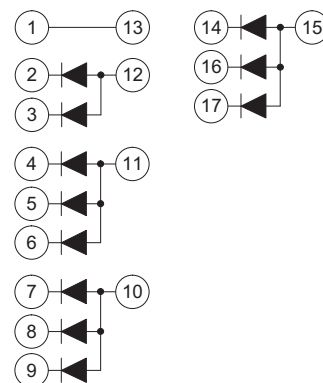

Diodes are all silicon type. (1S1588 or equivalent)

# CHAPTER 7. TROUBLESHOOTING

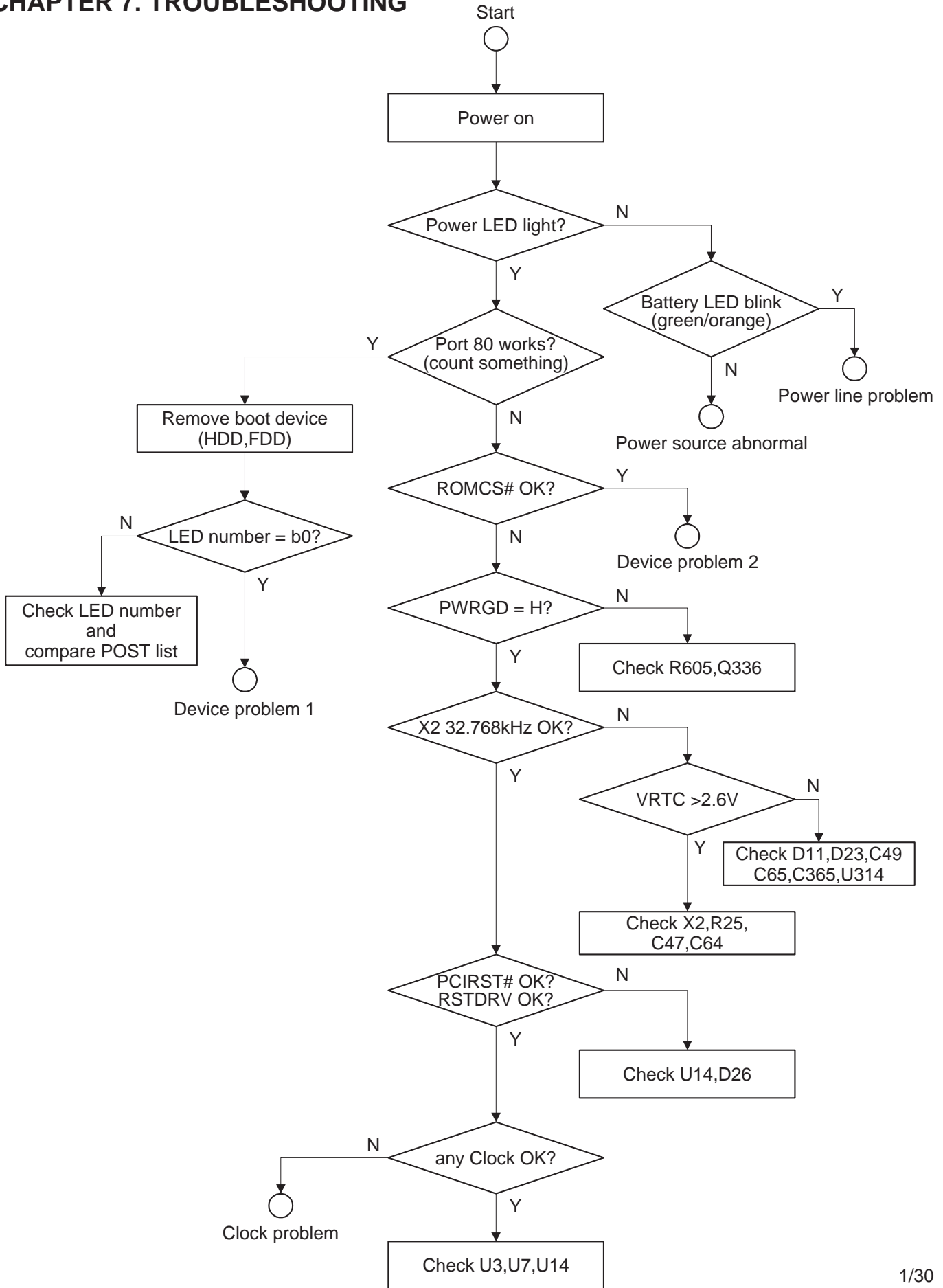

Device problem 1

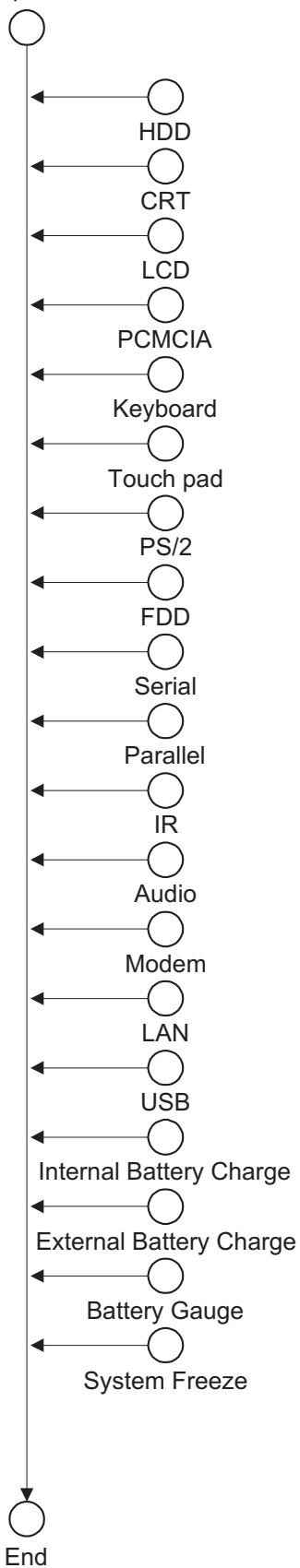

Device problem 2

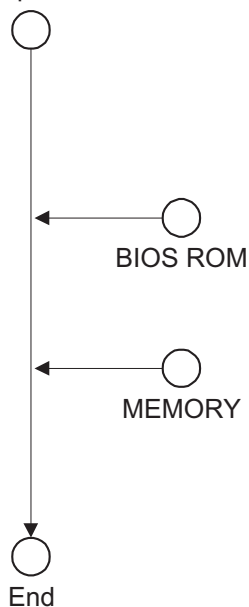

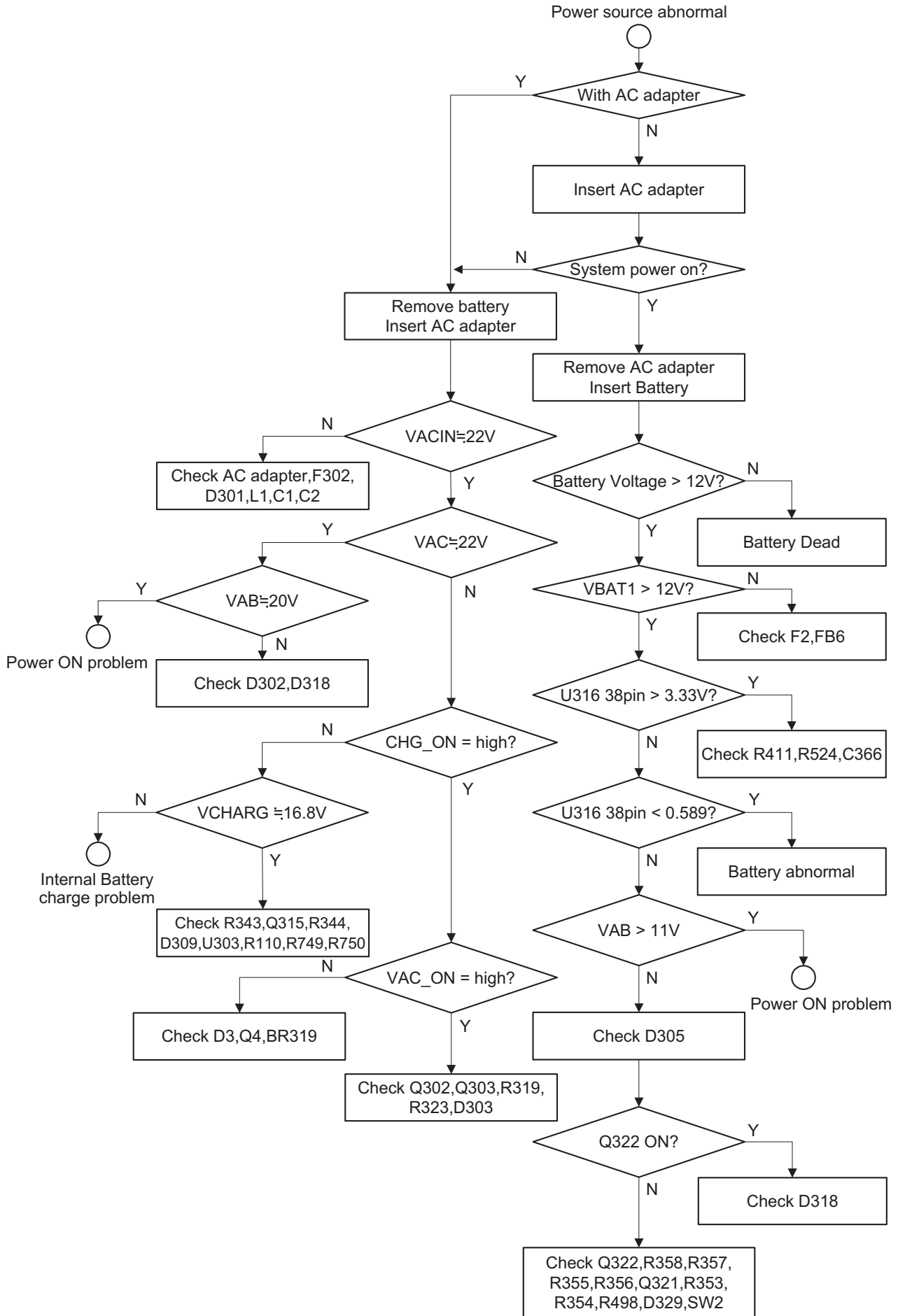

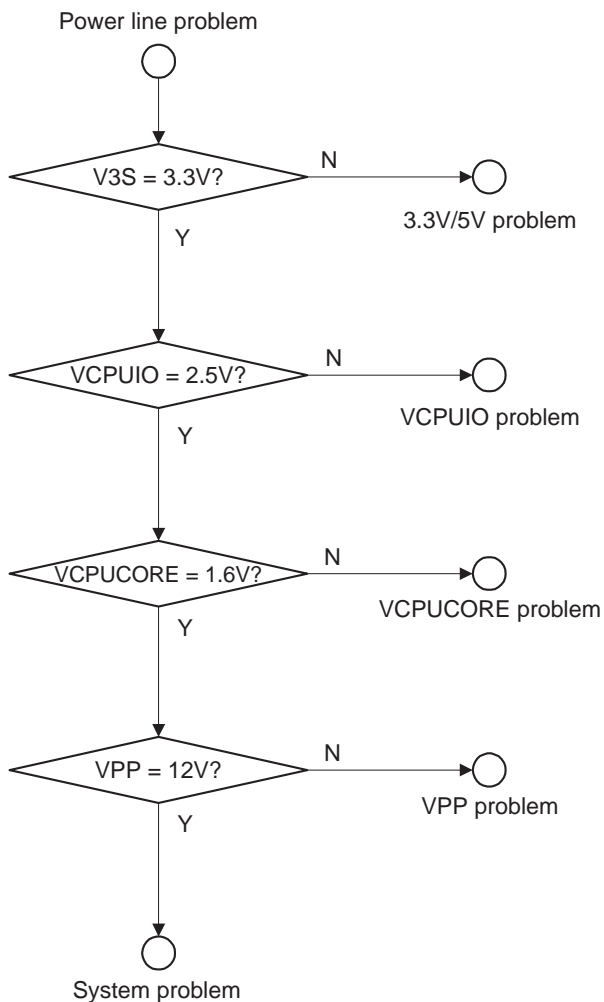
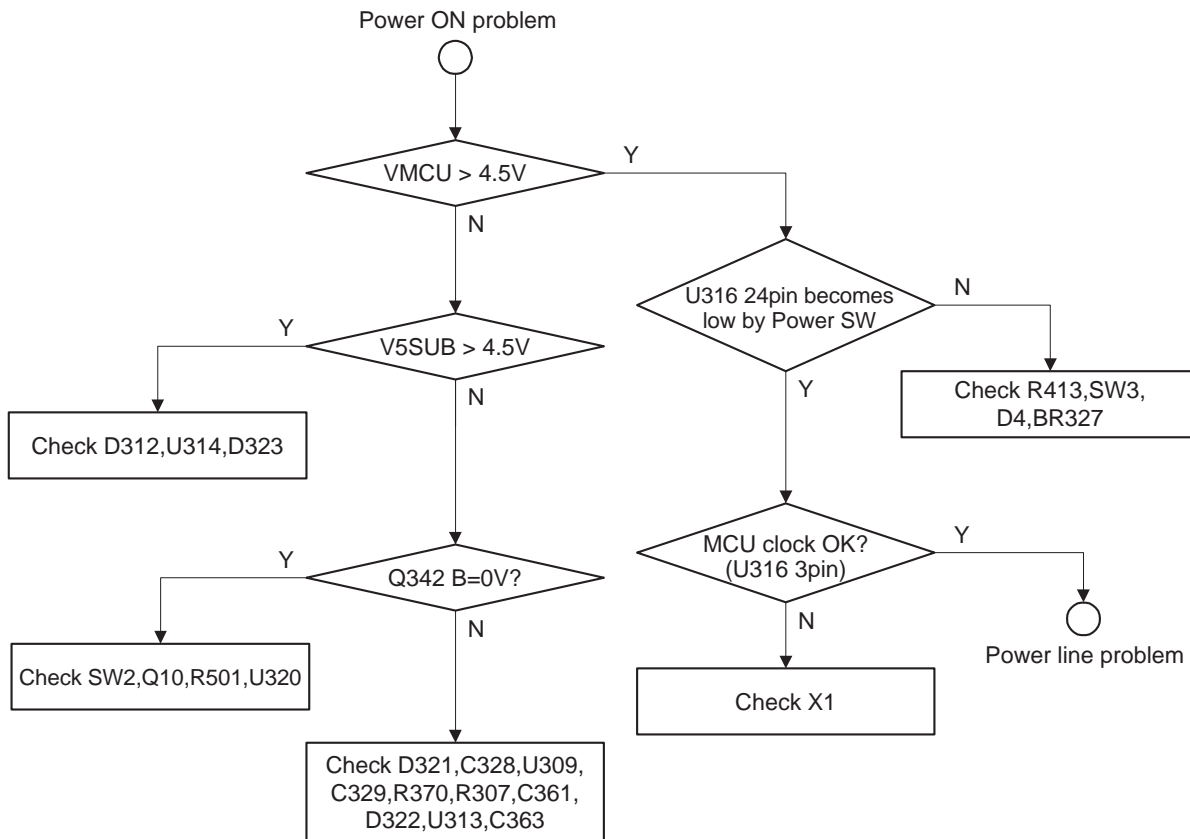

4/30

5/30

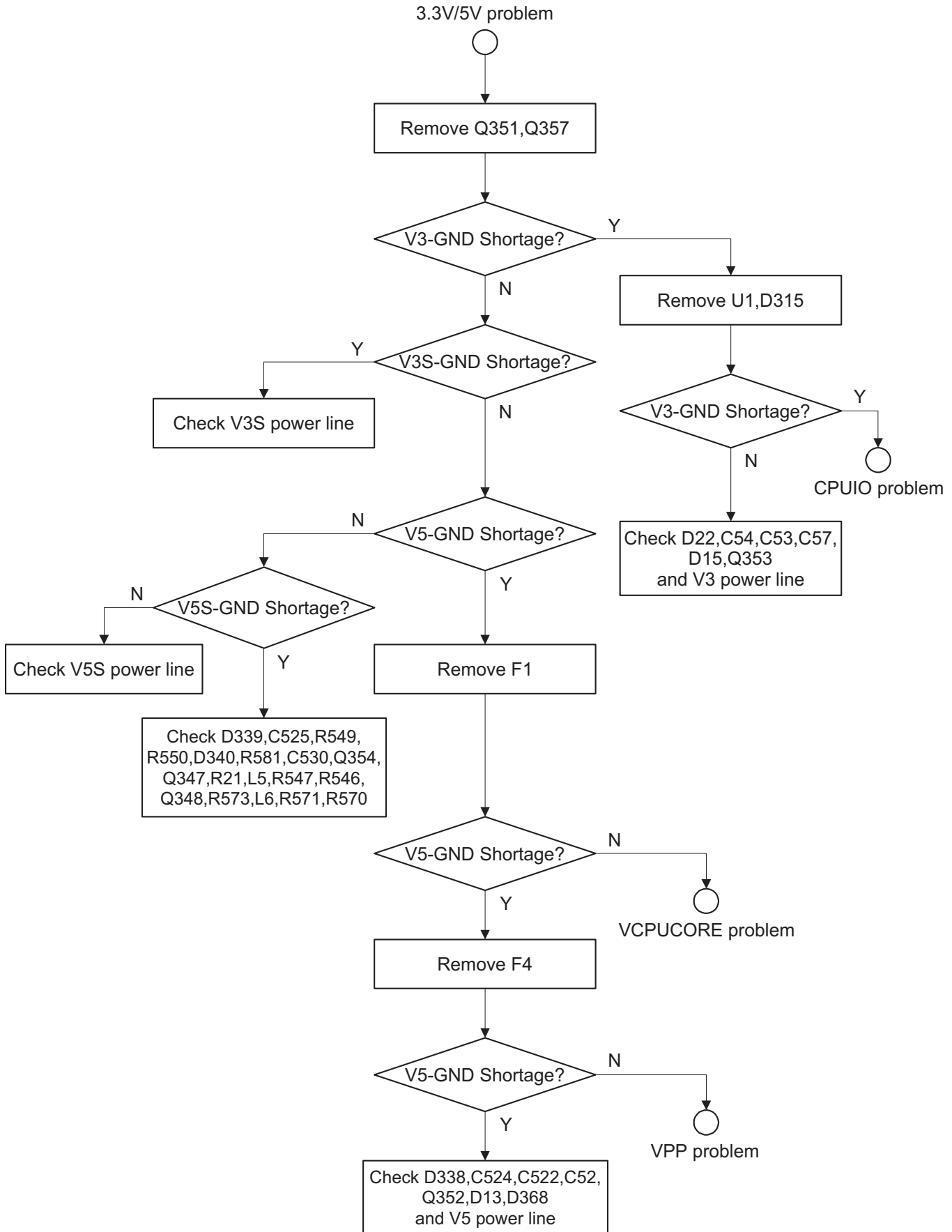

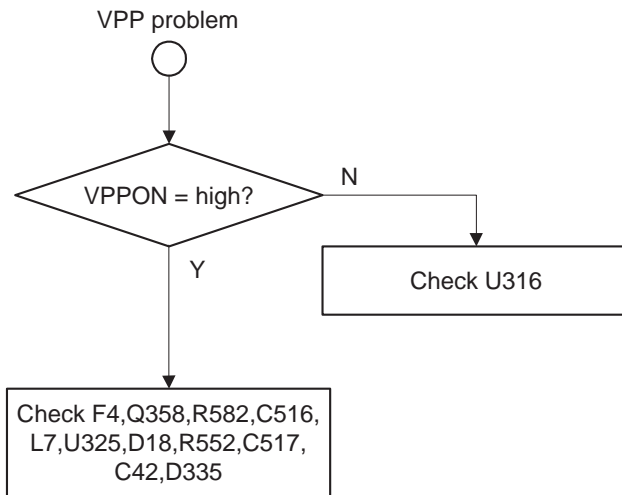
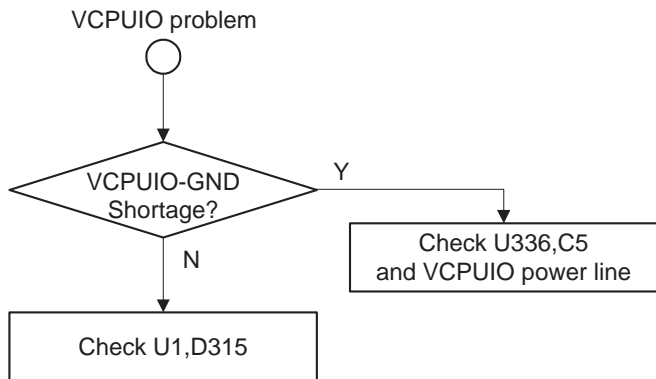

7/30

9/30

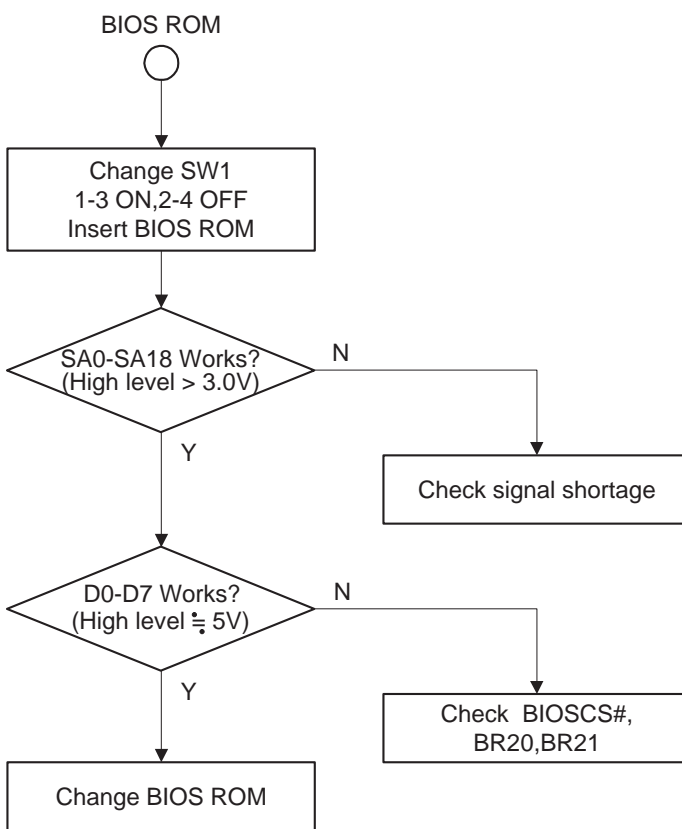
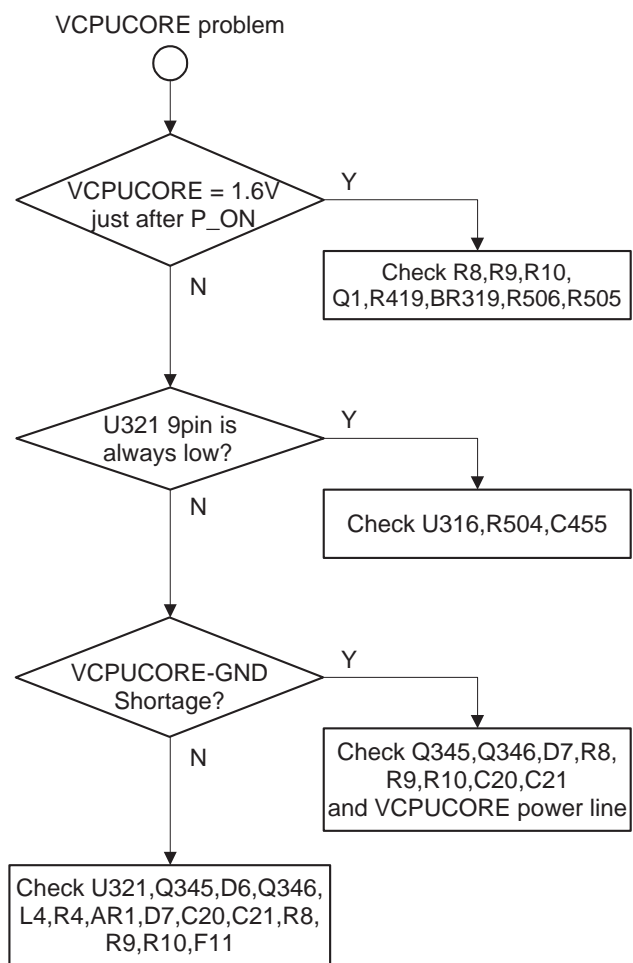

8/30

10/30

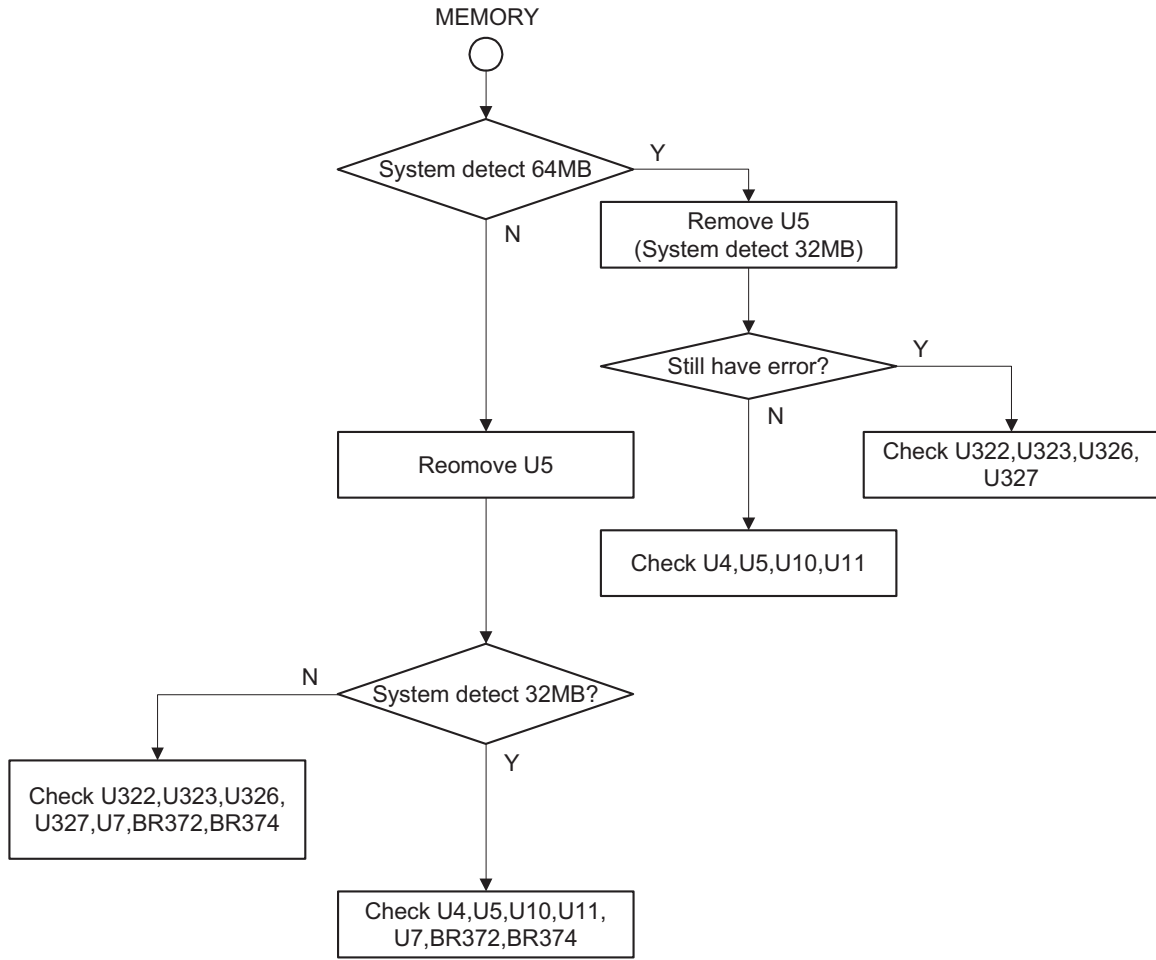

11/30

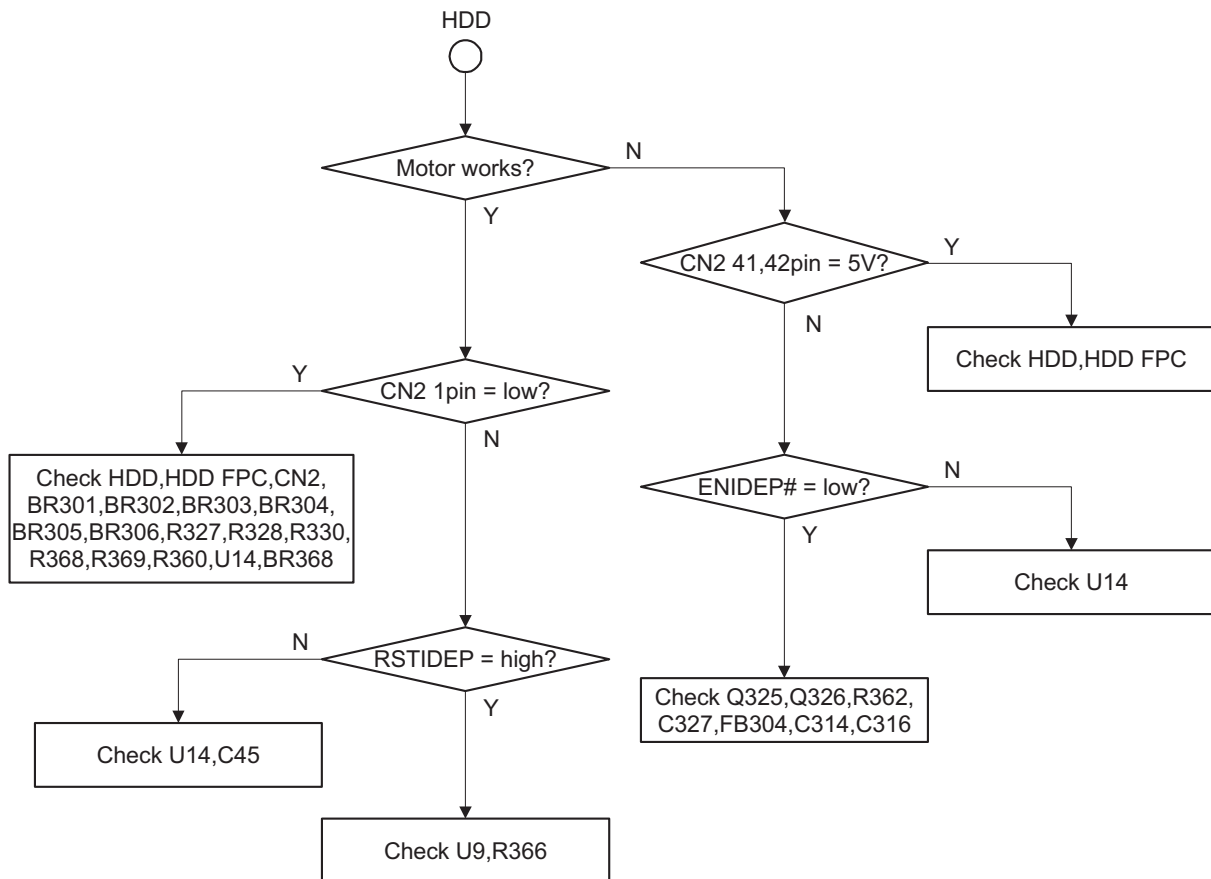

12/30

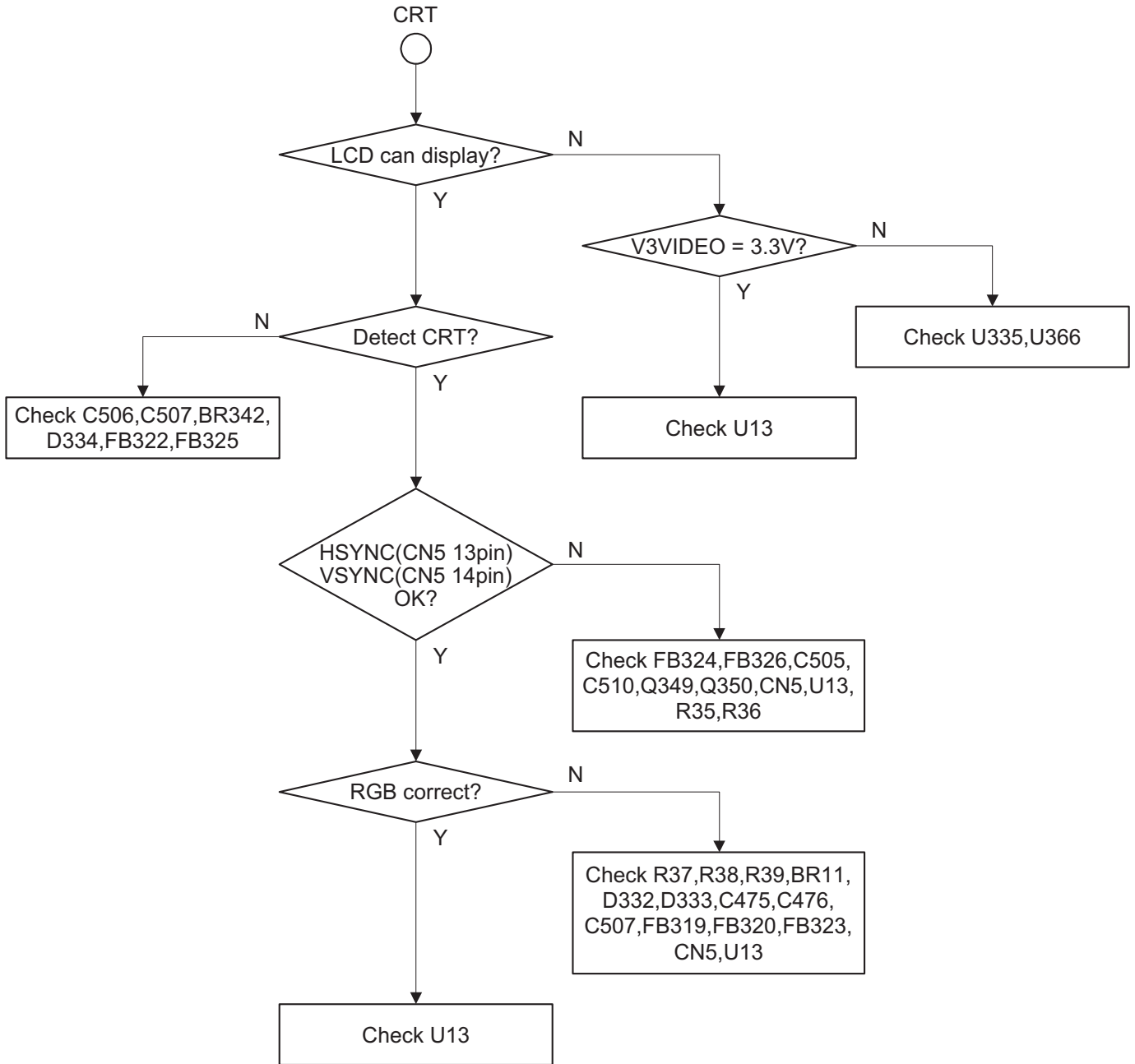

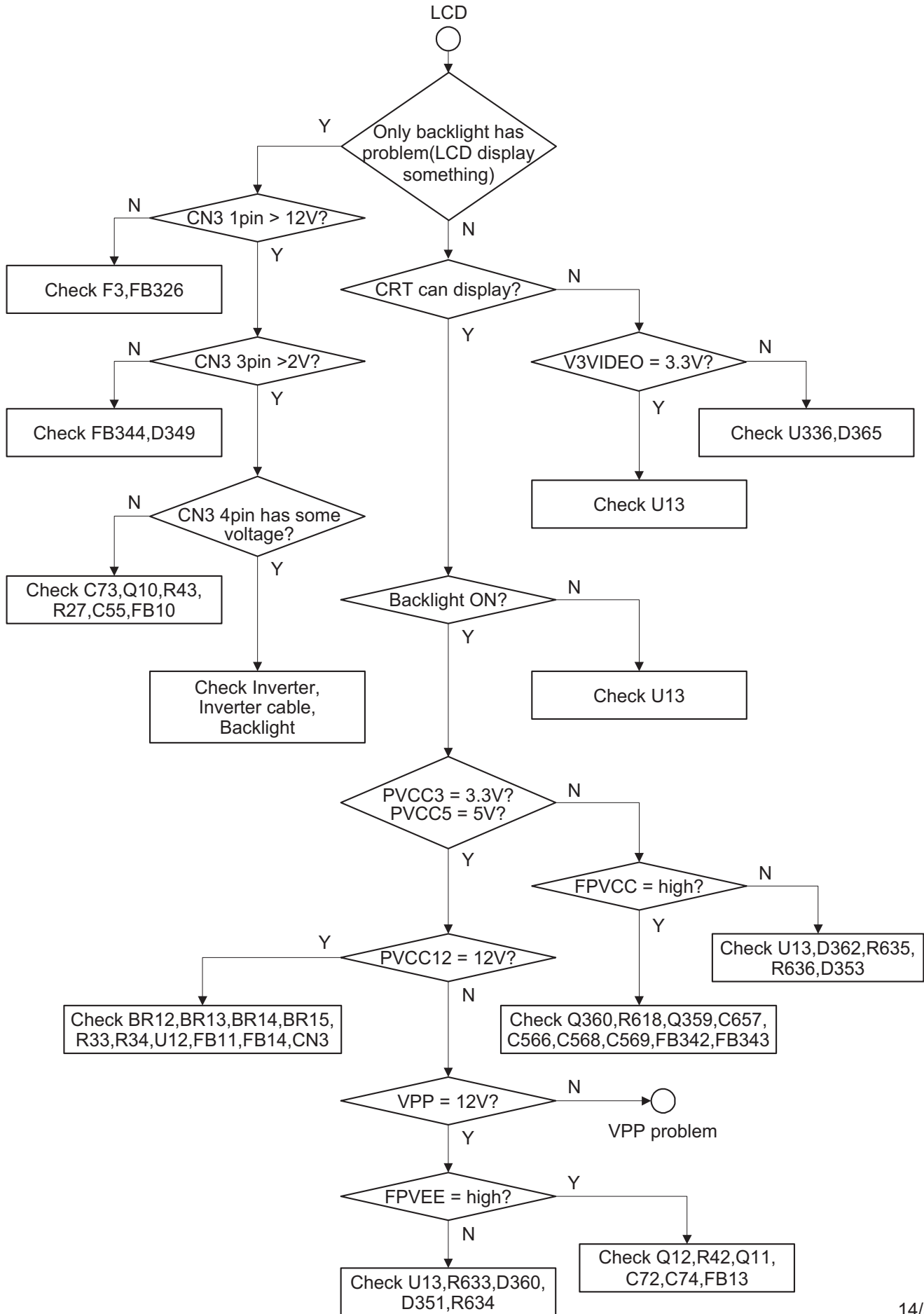

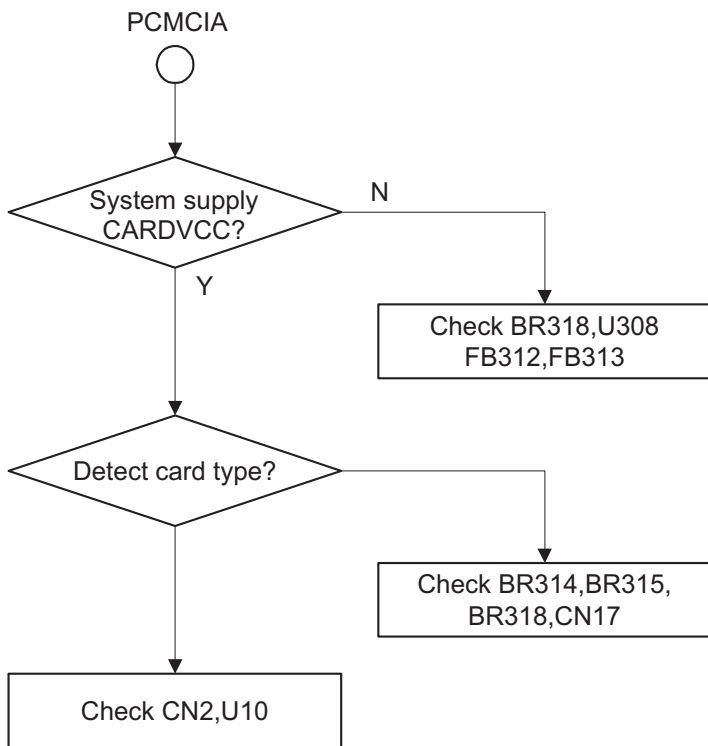

15/30

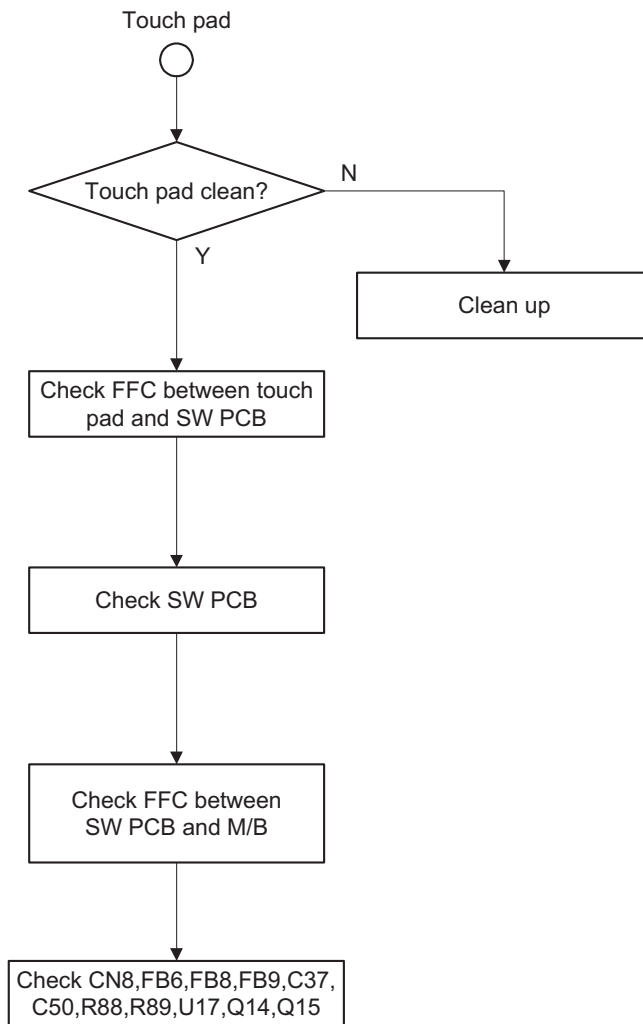

17/30

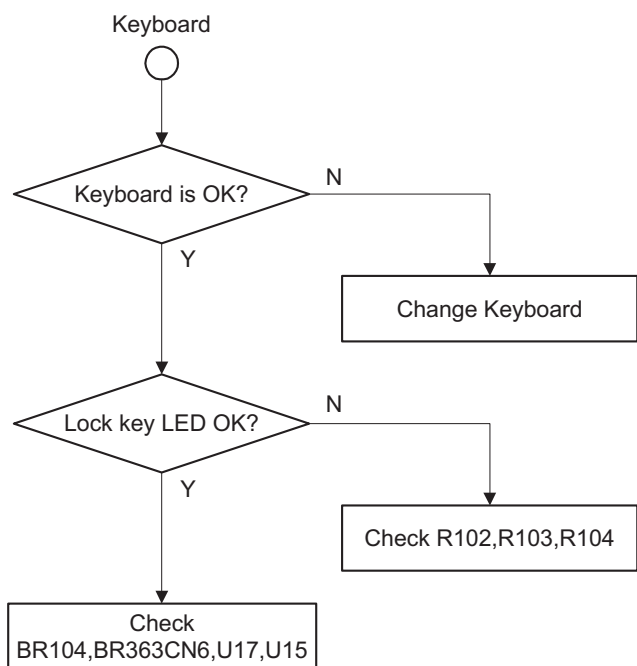

16/30

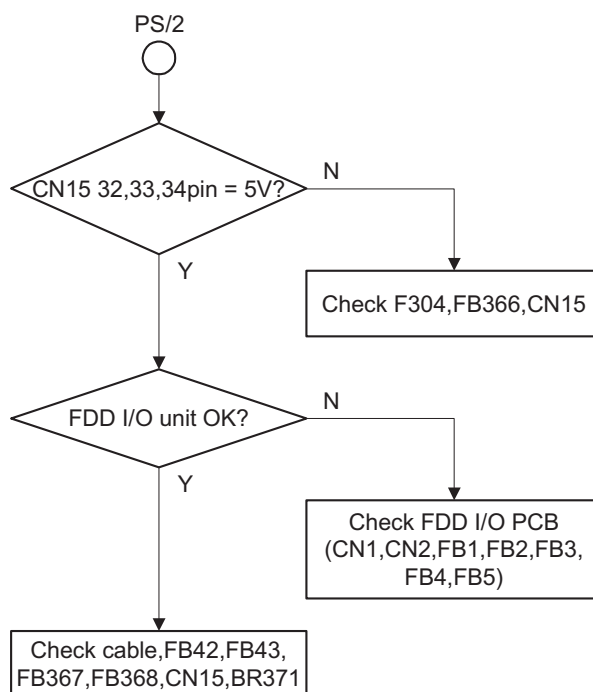

18/30

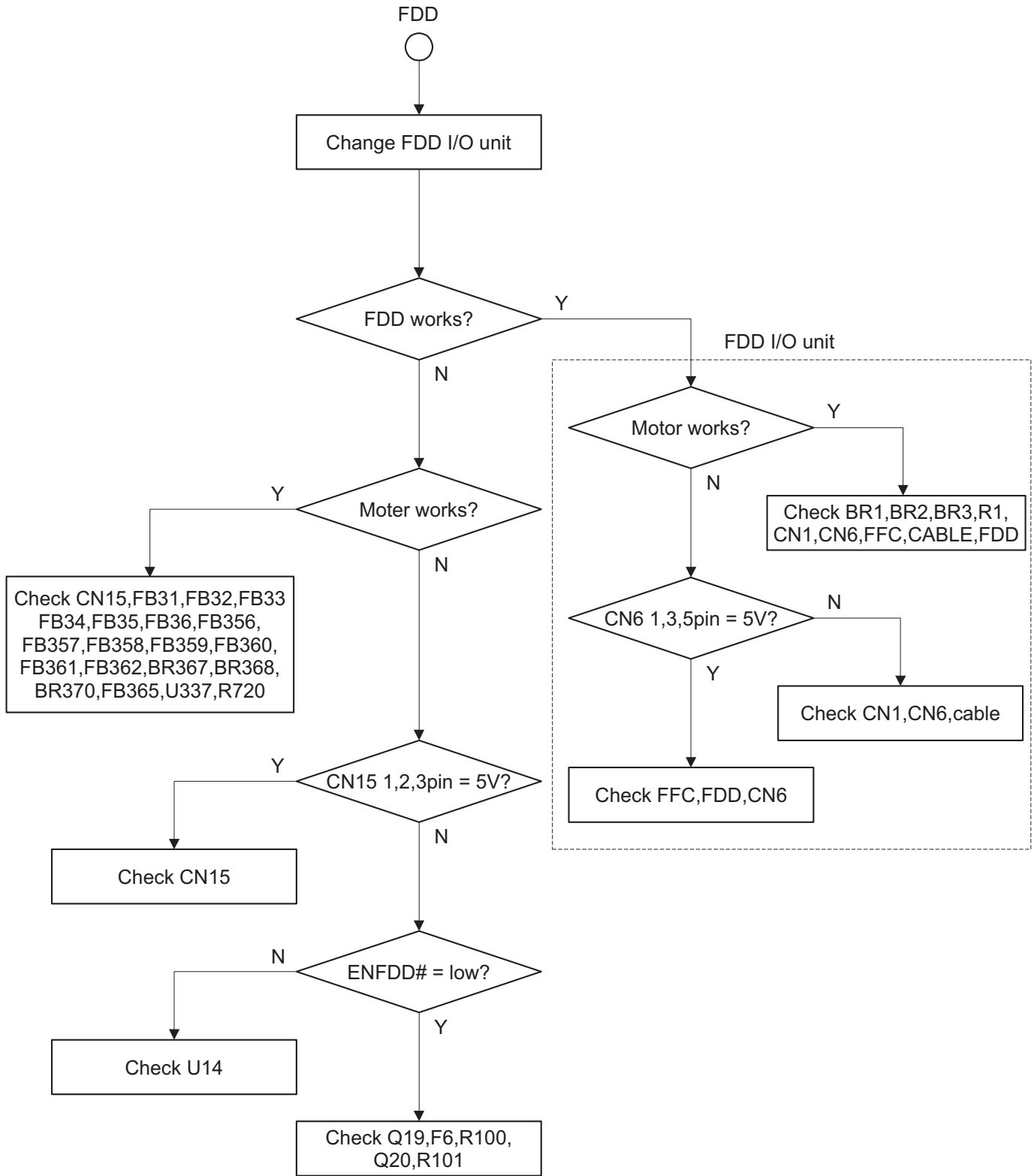

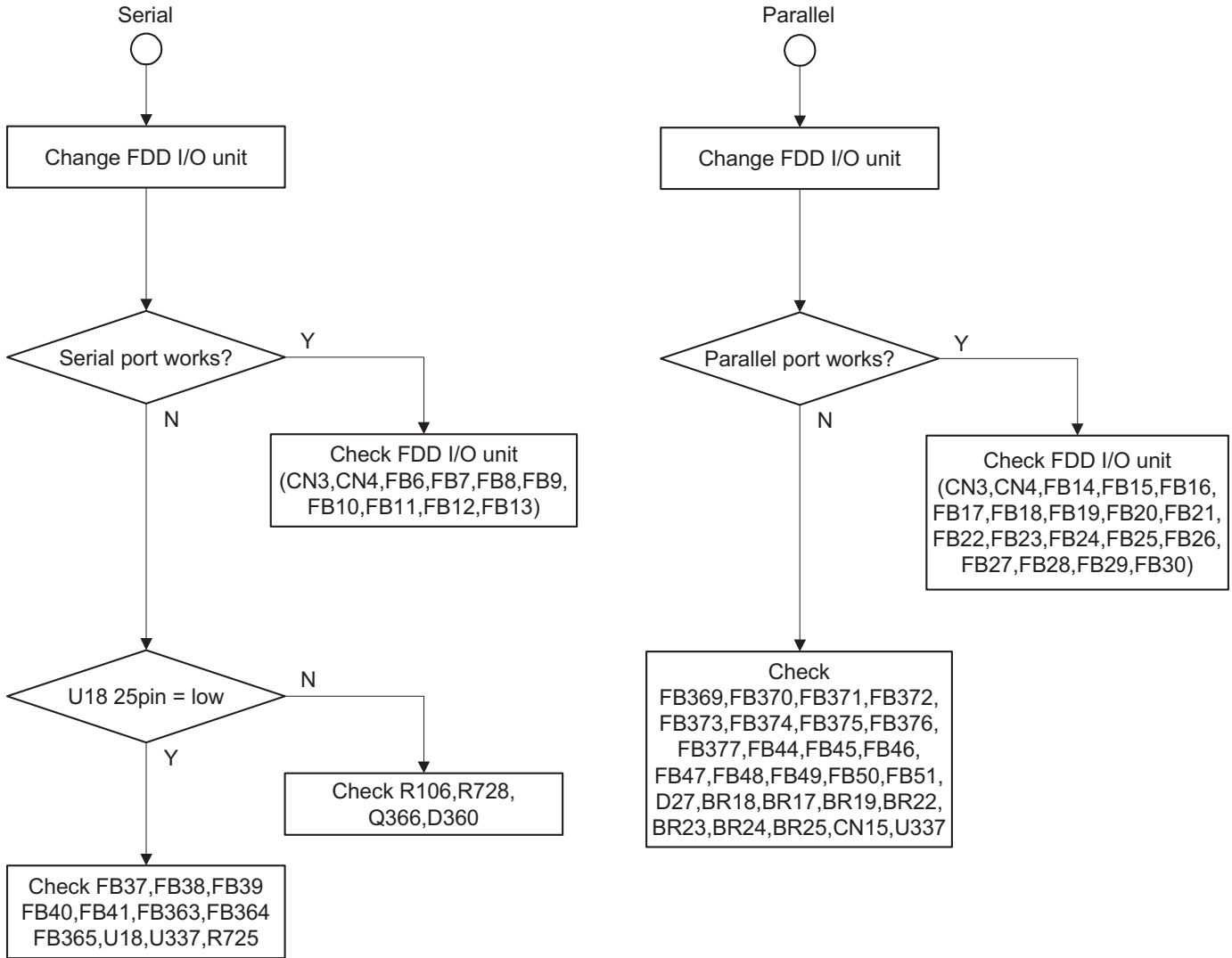

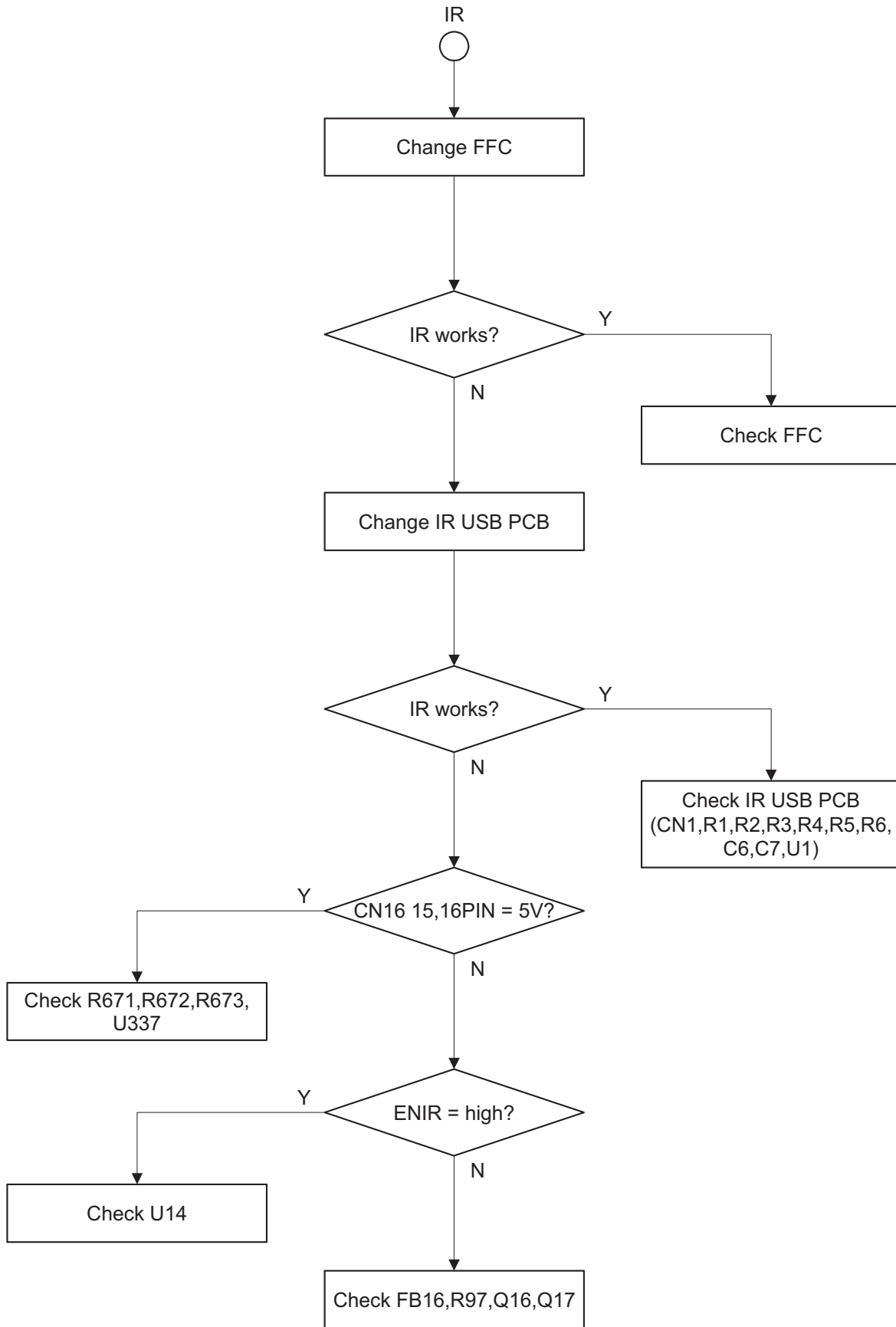

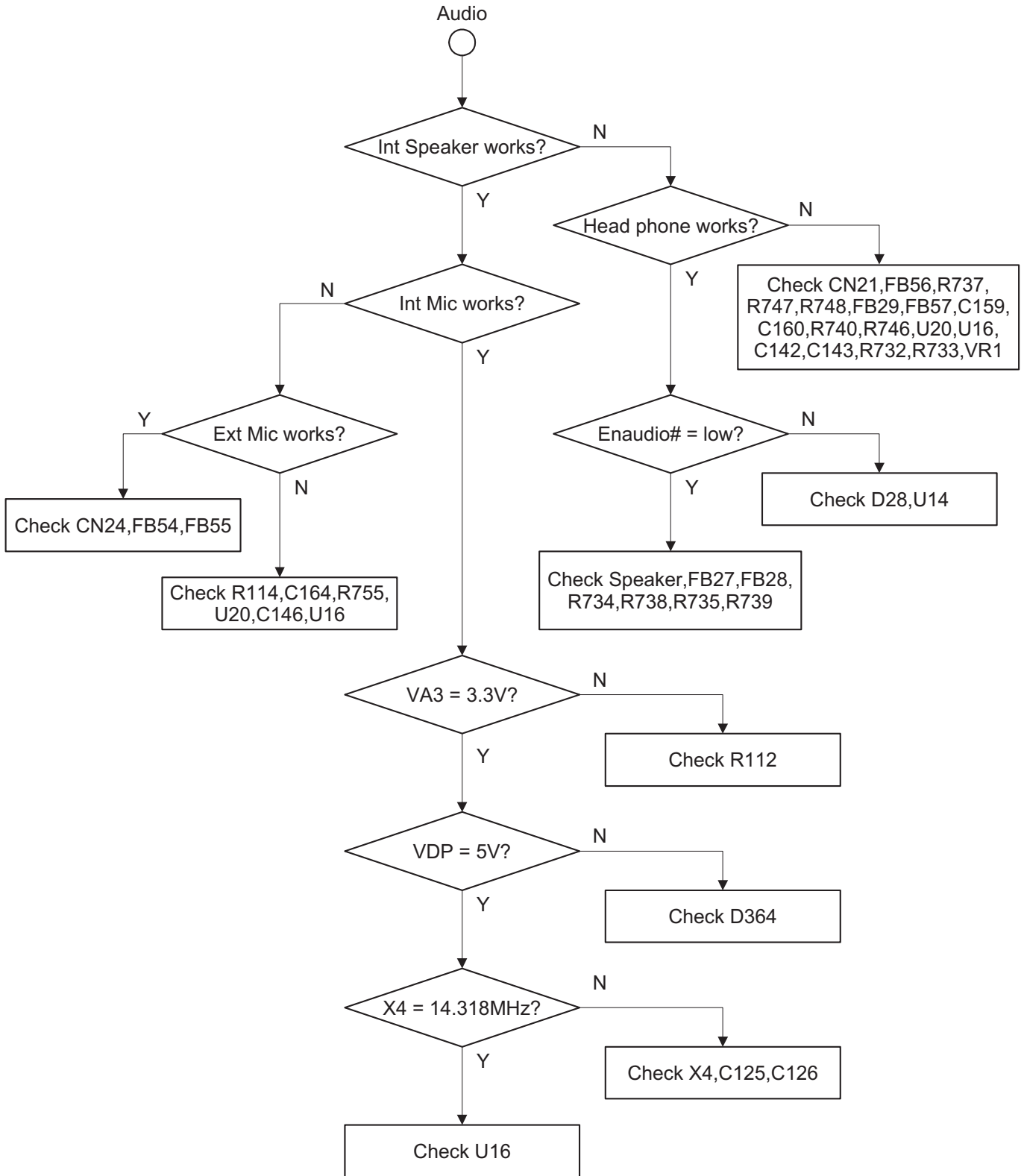

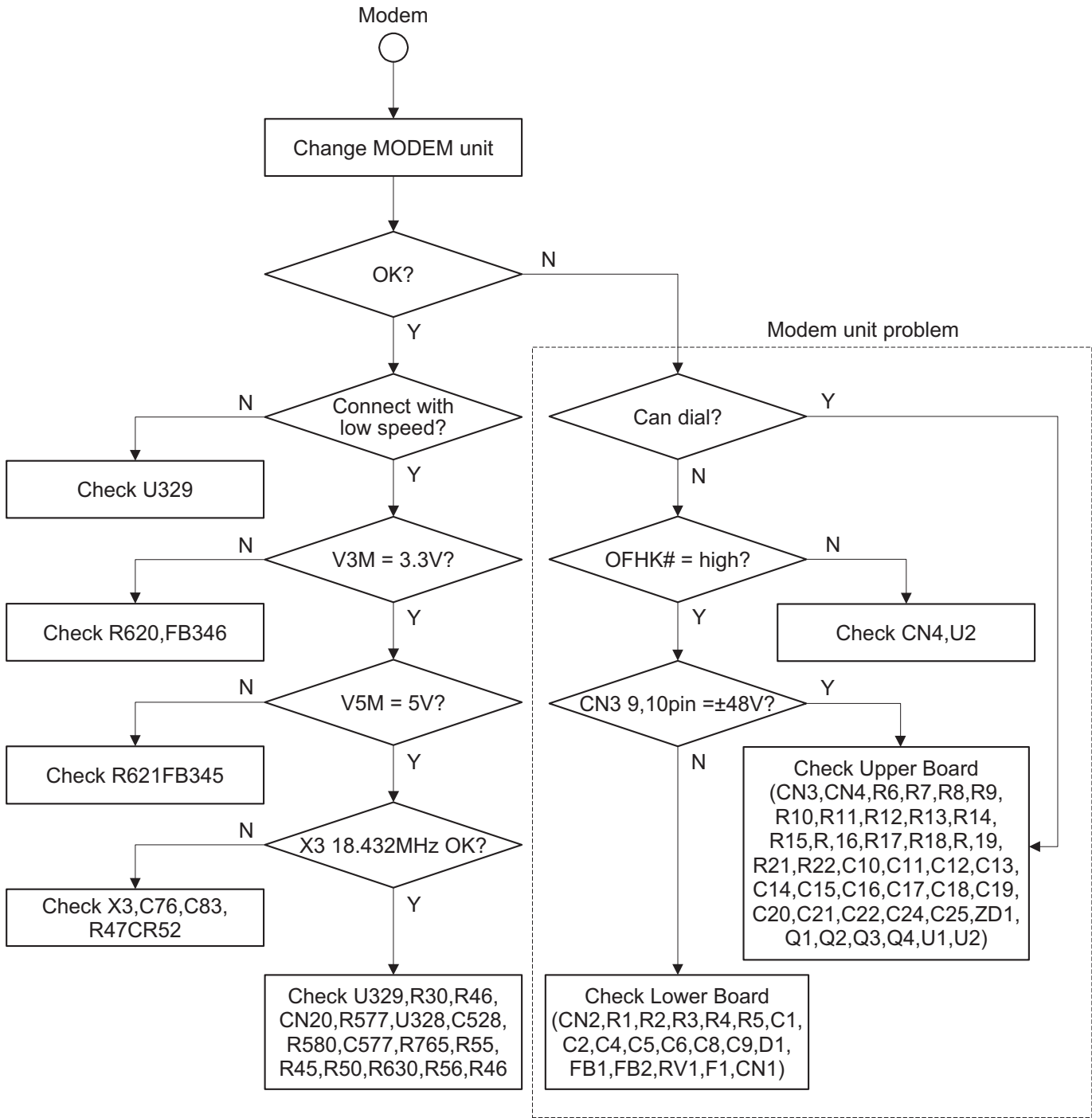

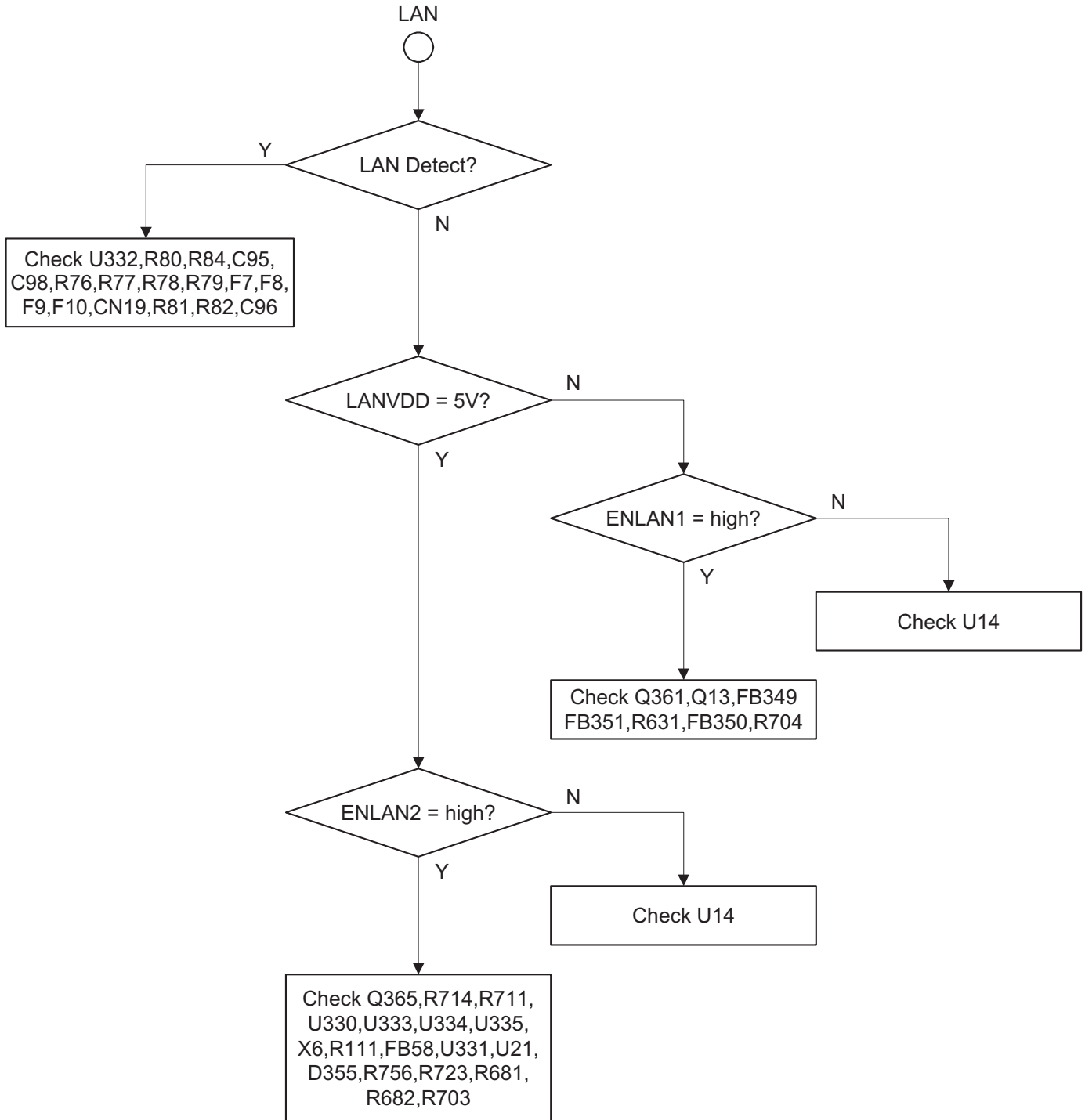

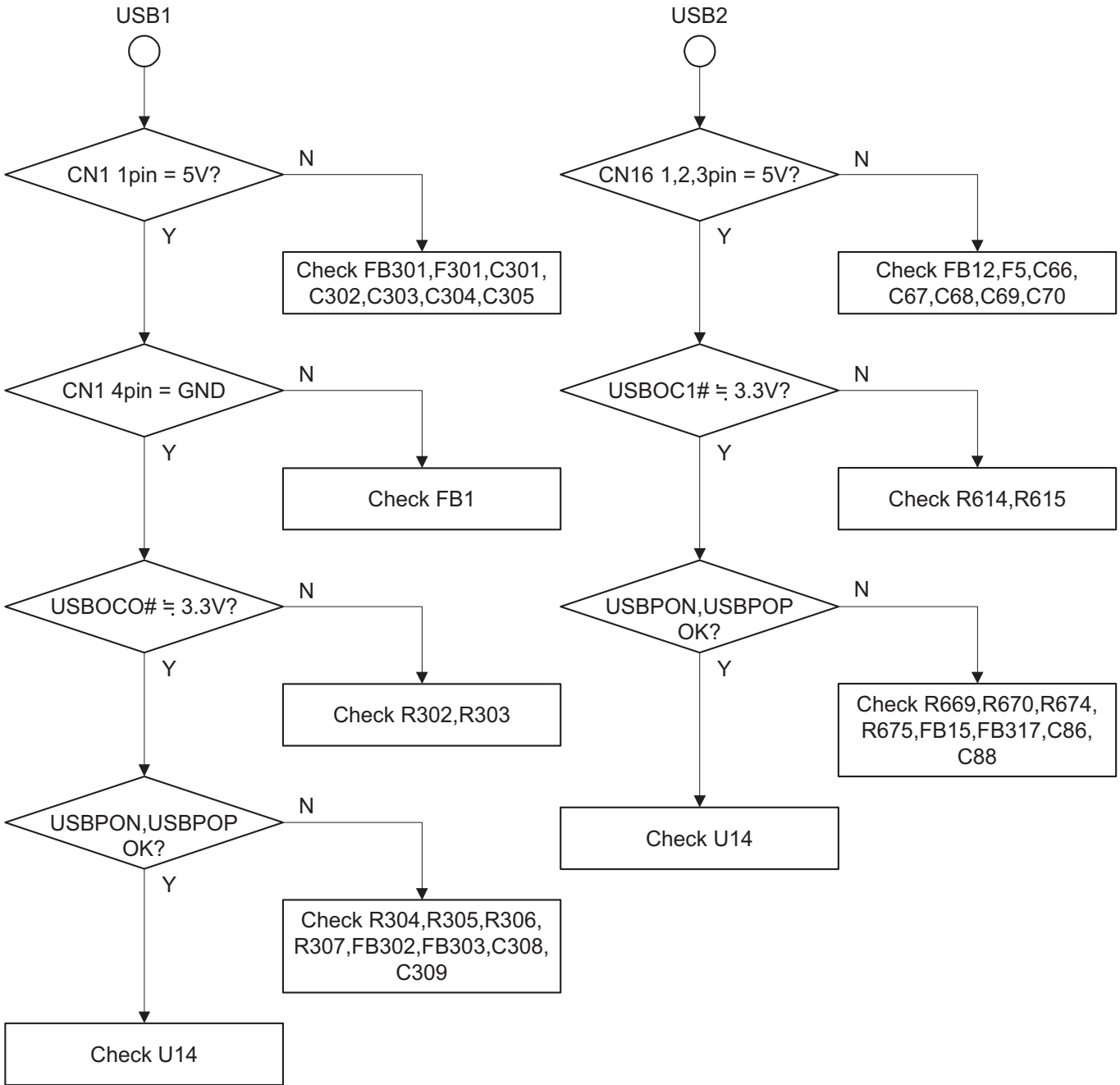

Internal Battery charge problem

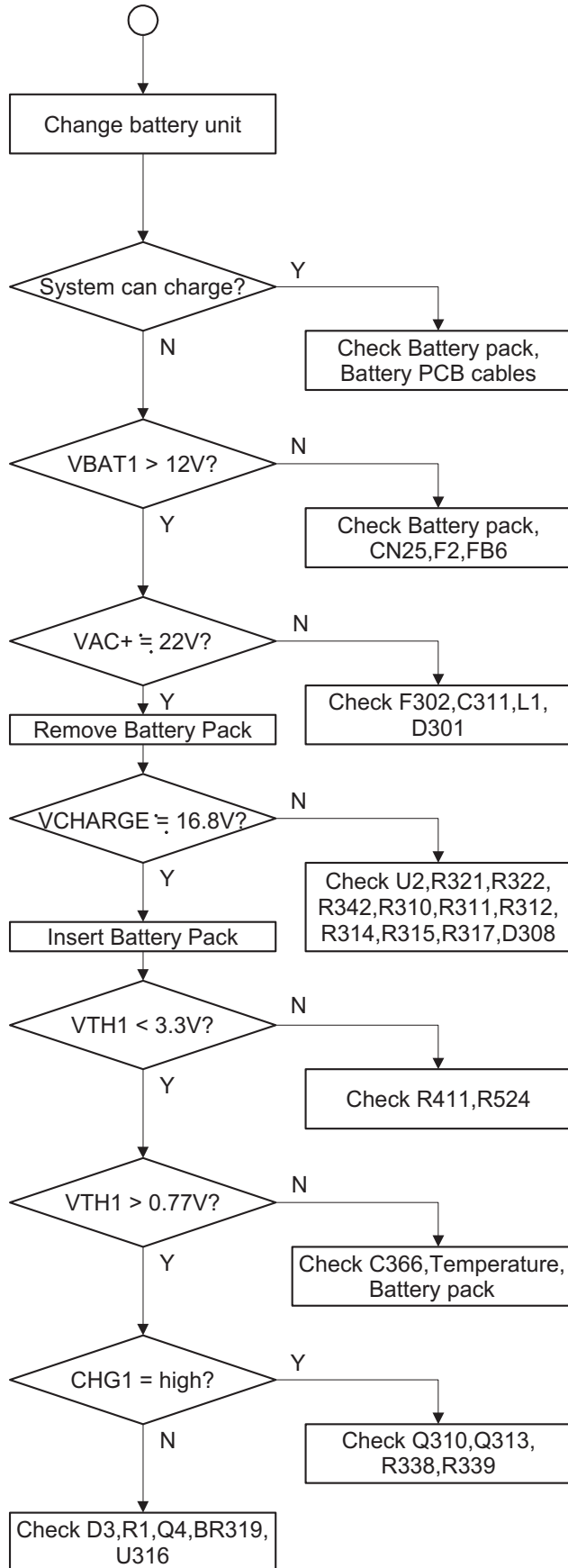

External Battery charge problem

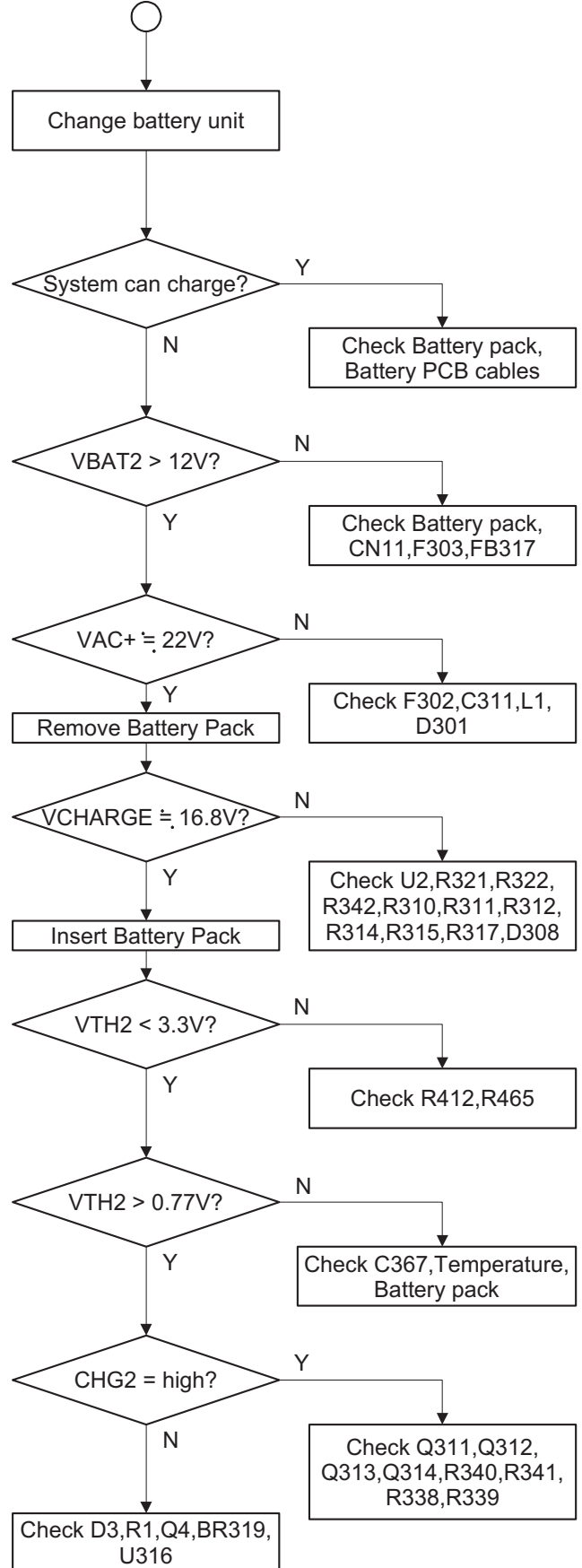

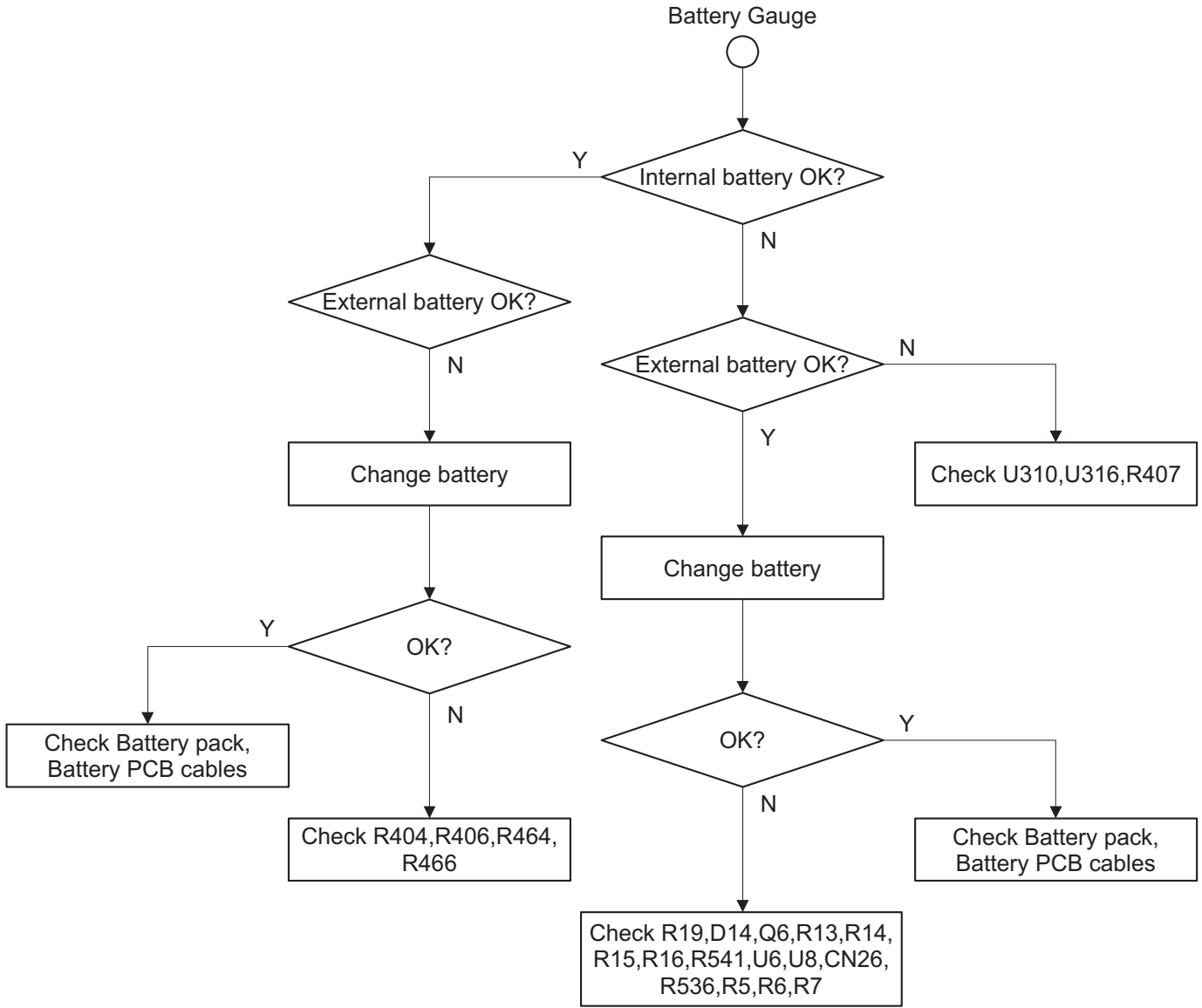

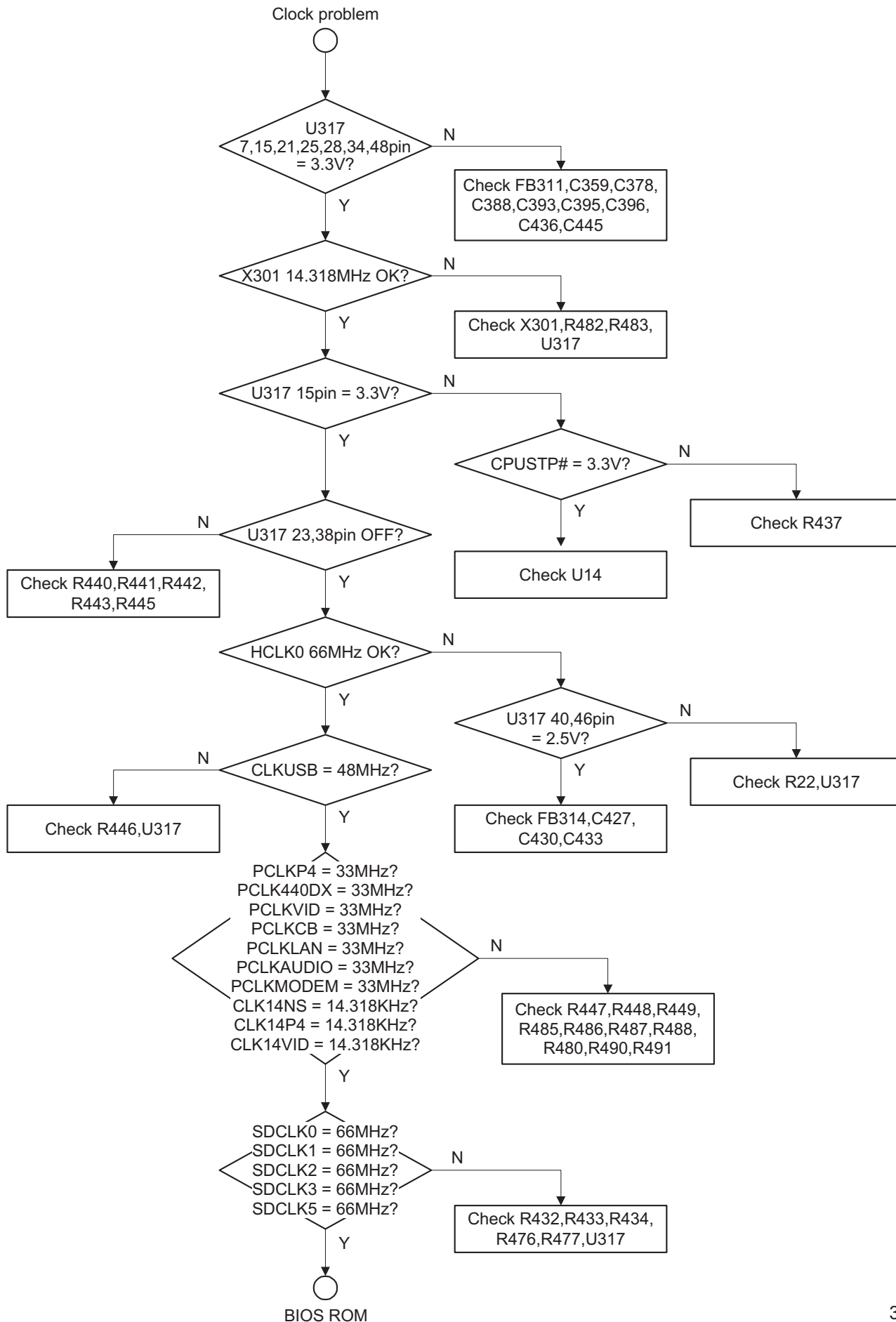

# CHAPTER 8. BLOCK DIAGRAM

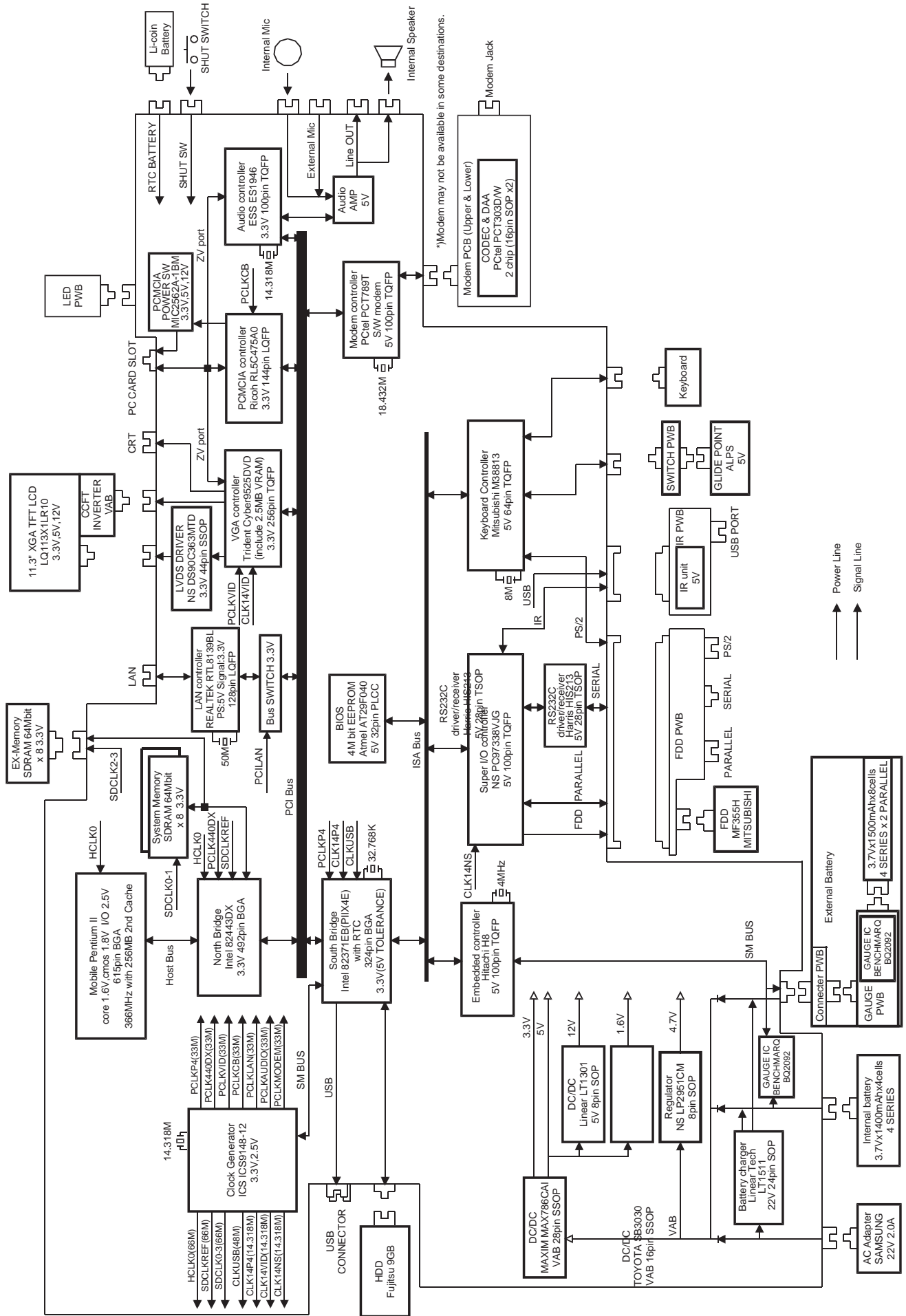

# CHAPTER 9. CIRCUIT DIAGRAM AND PARTS LAYOUT

## CIRCUIT DIAGRAM

### TOP (REV 1.0)

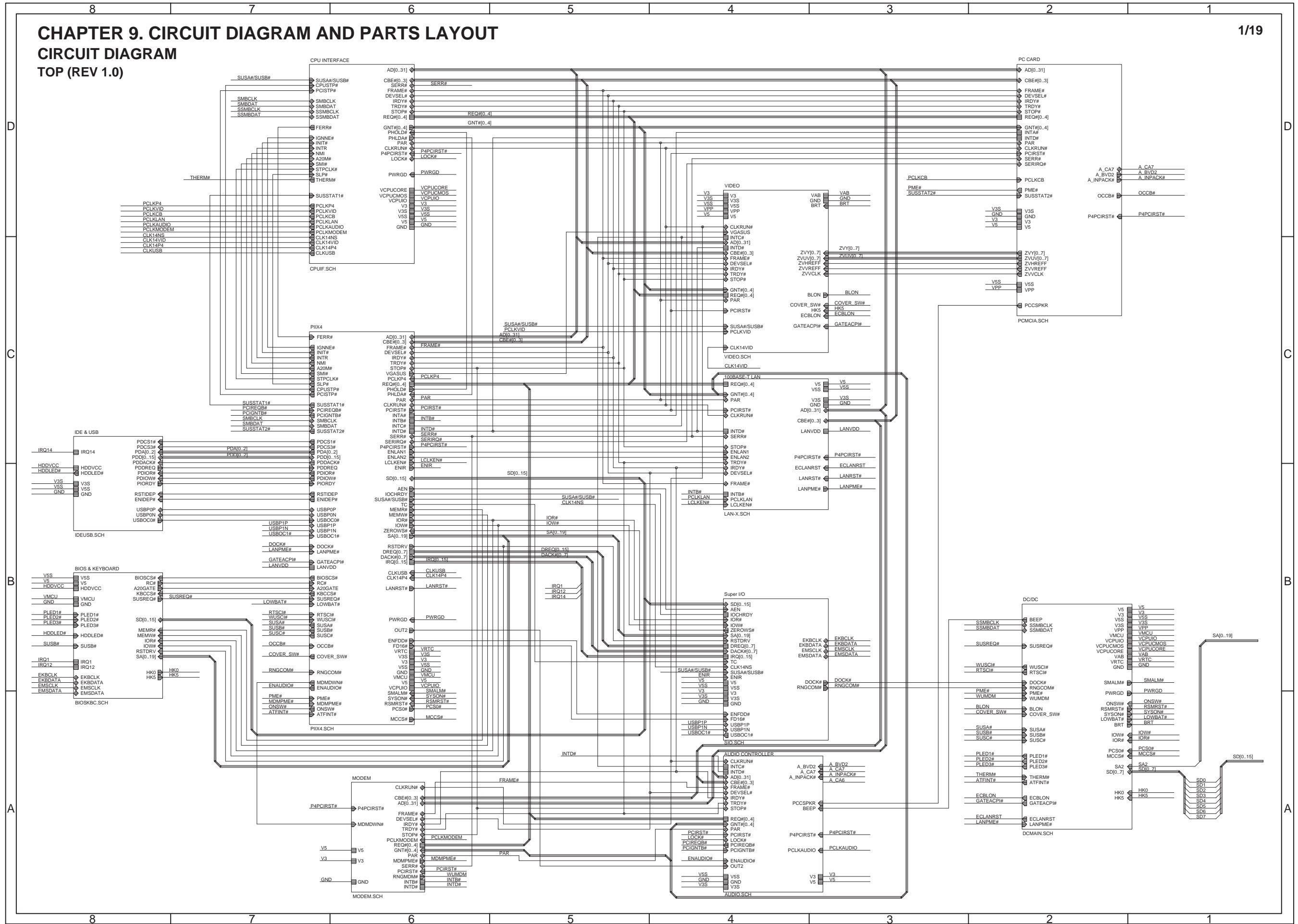

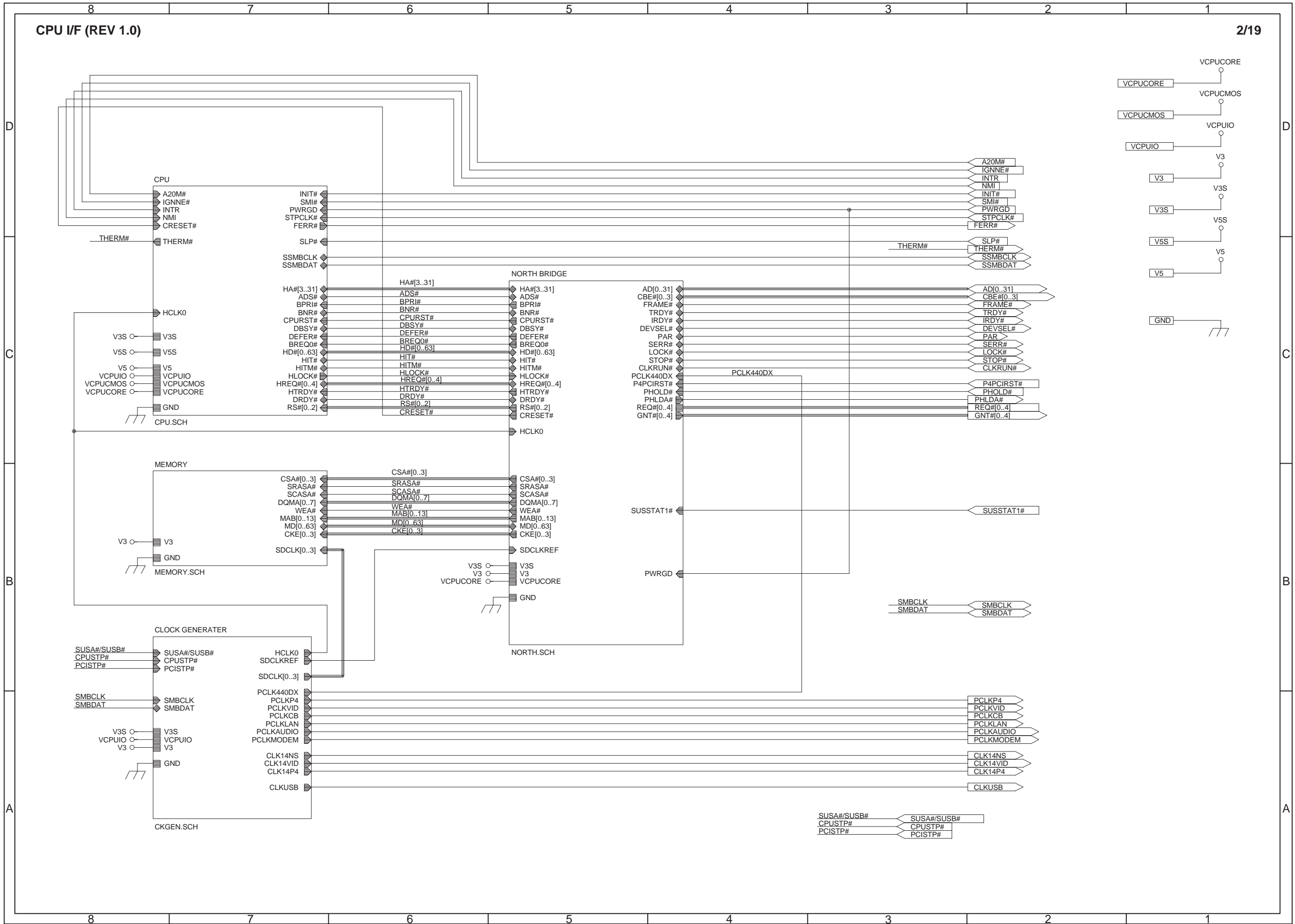

CPU (REV 1.0)

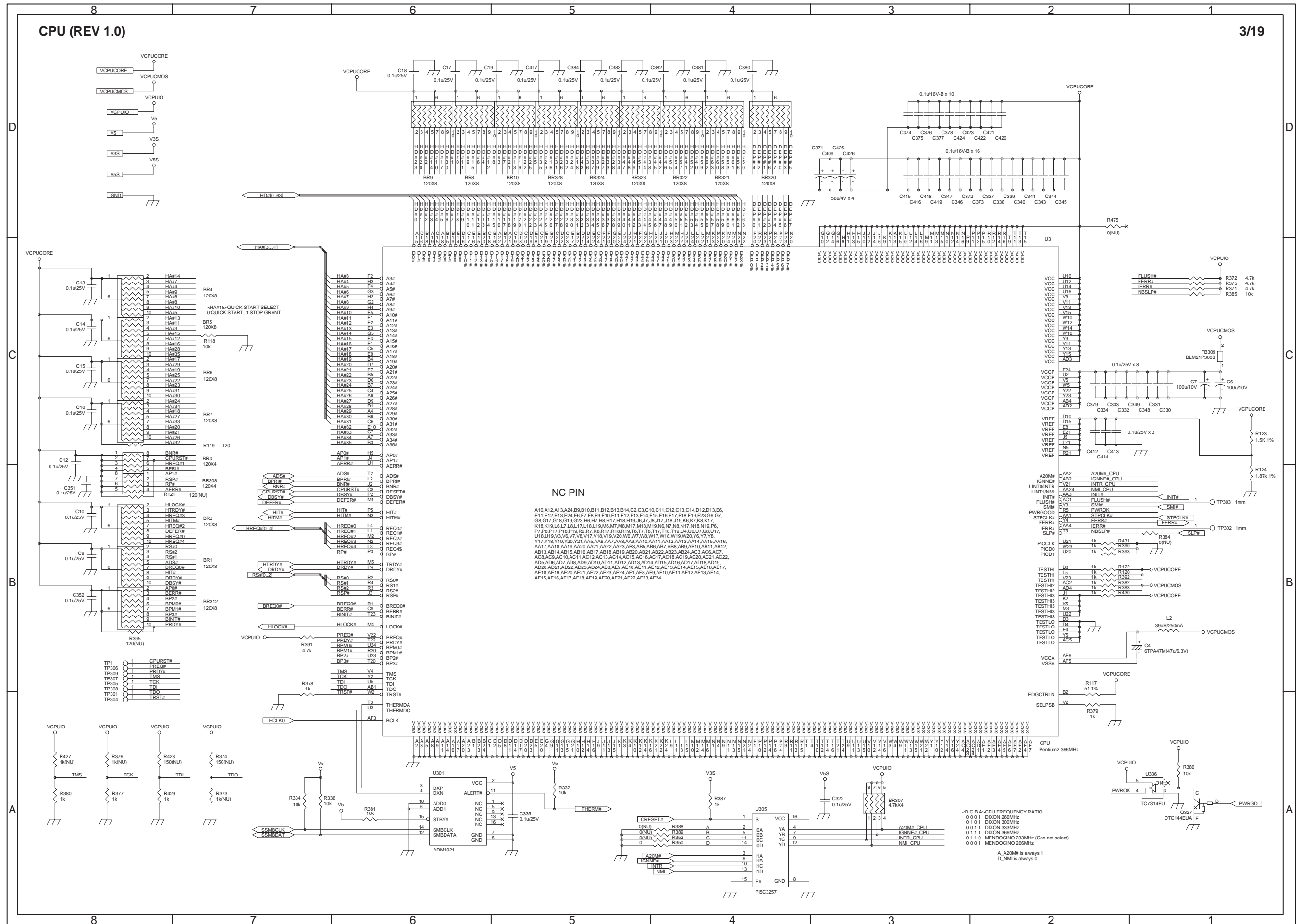

# CLOCK GENERATOR (REV 1.0)

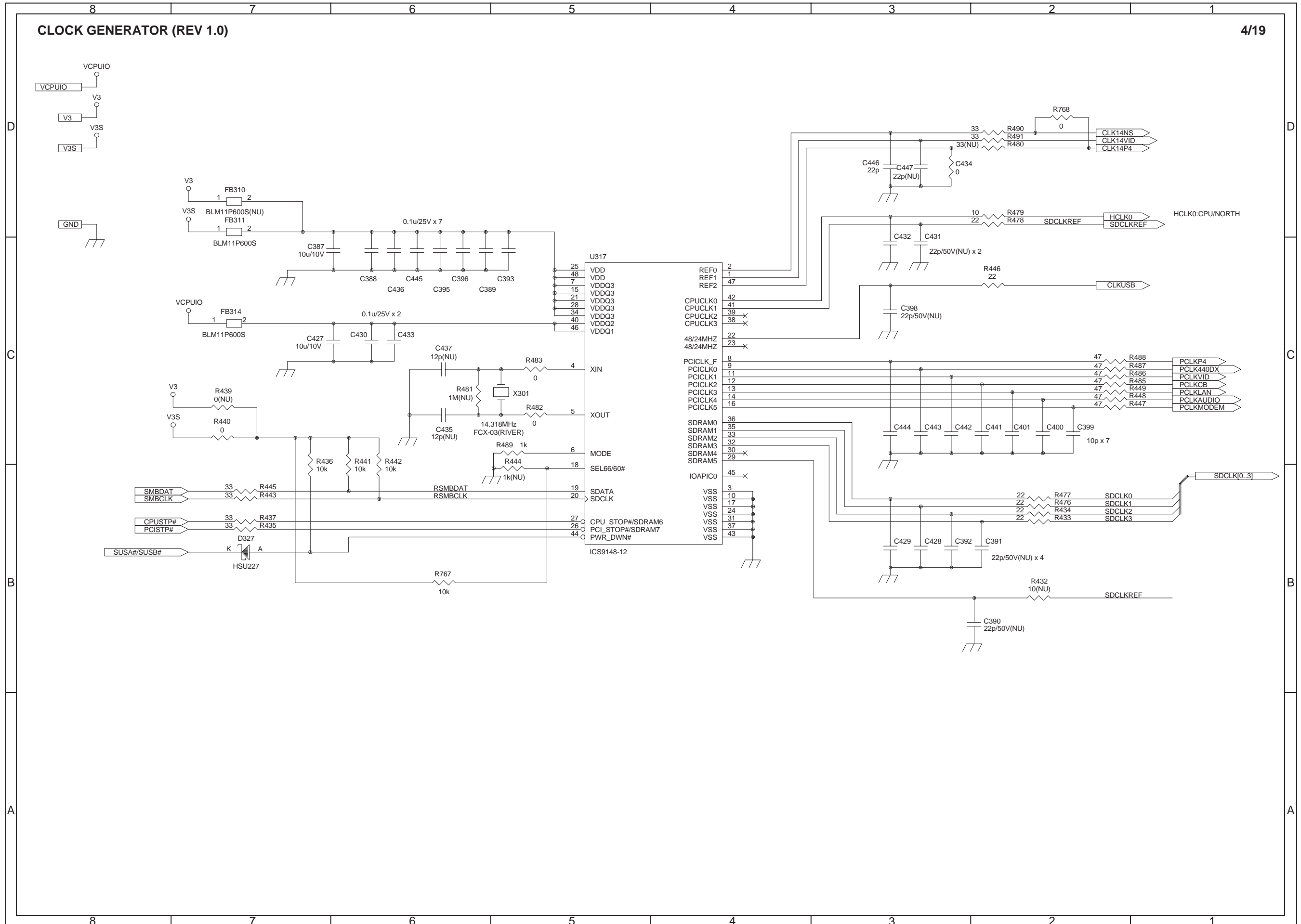

NORTH BRIDGE (REV 1.0)

NORTH BRIDGE

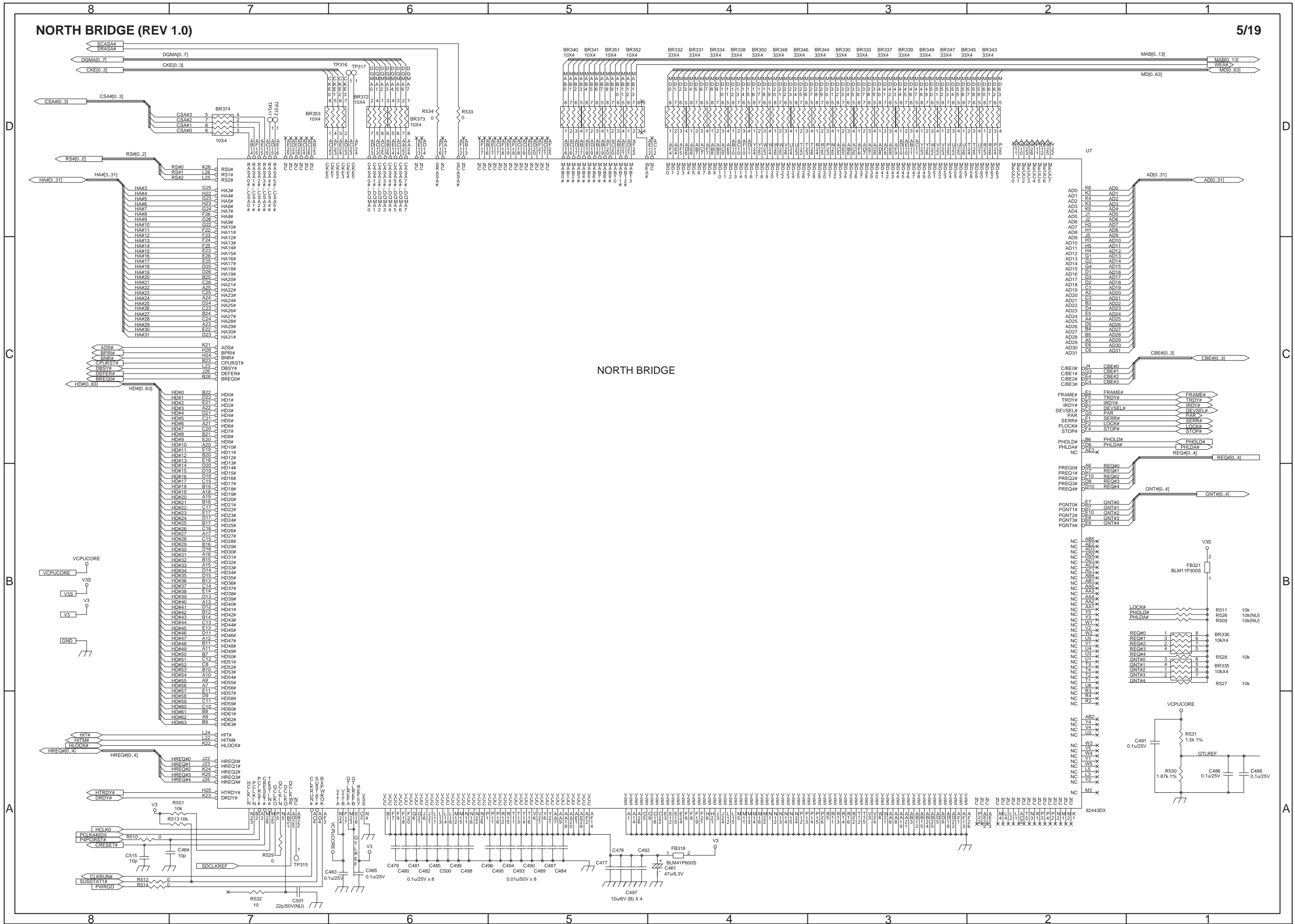

MEMORY BOARD (REV 1.0)

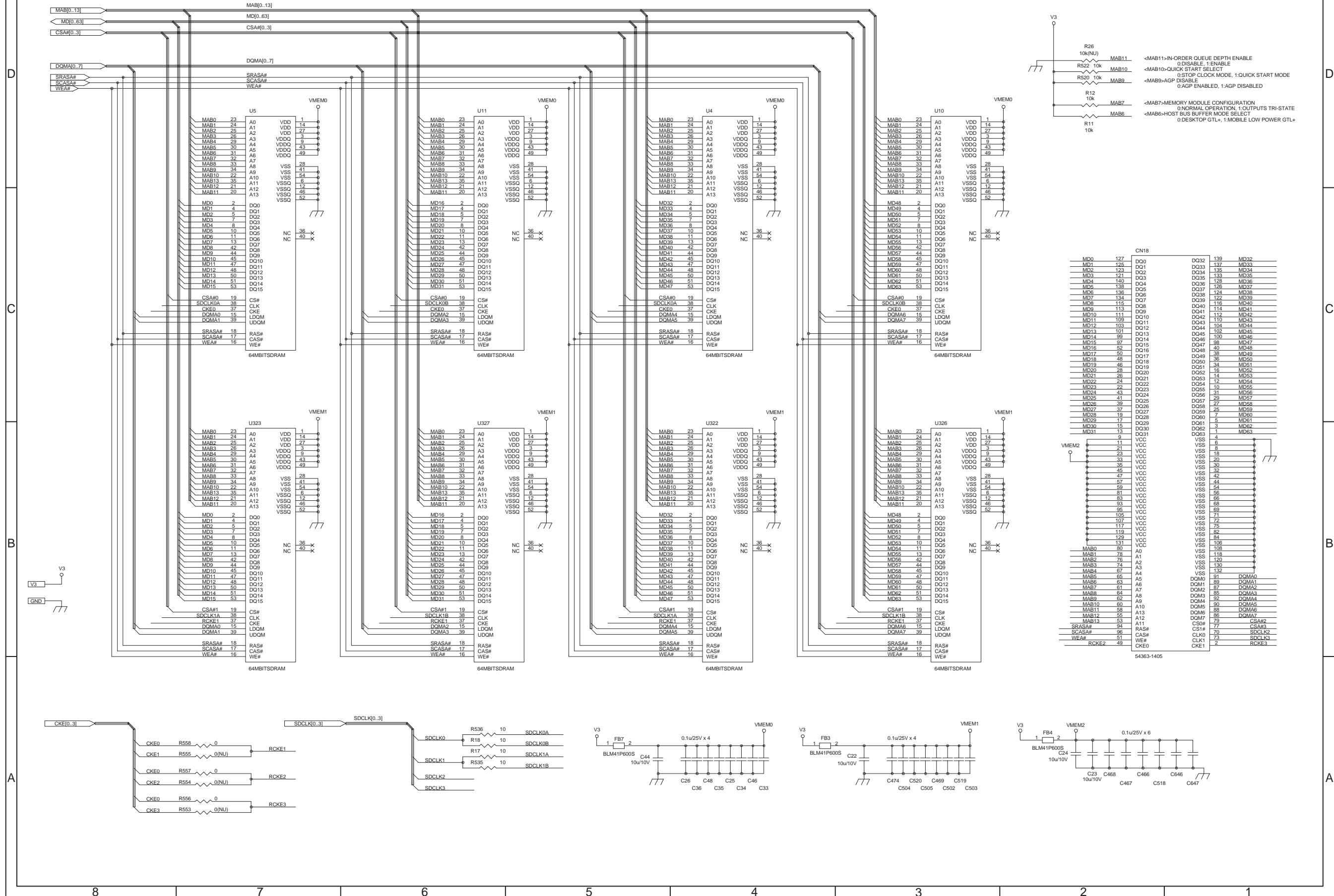

SOUTH BRIDGE (REV 1.0)

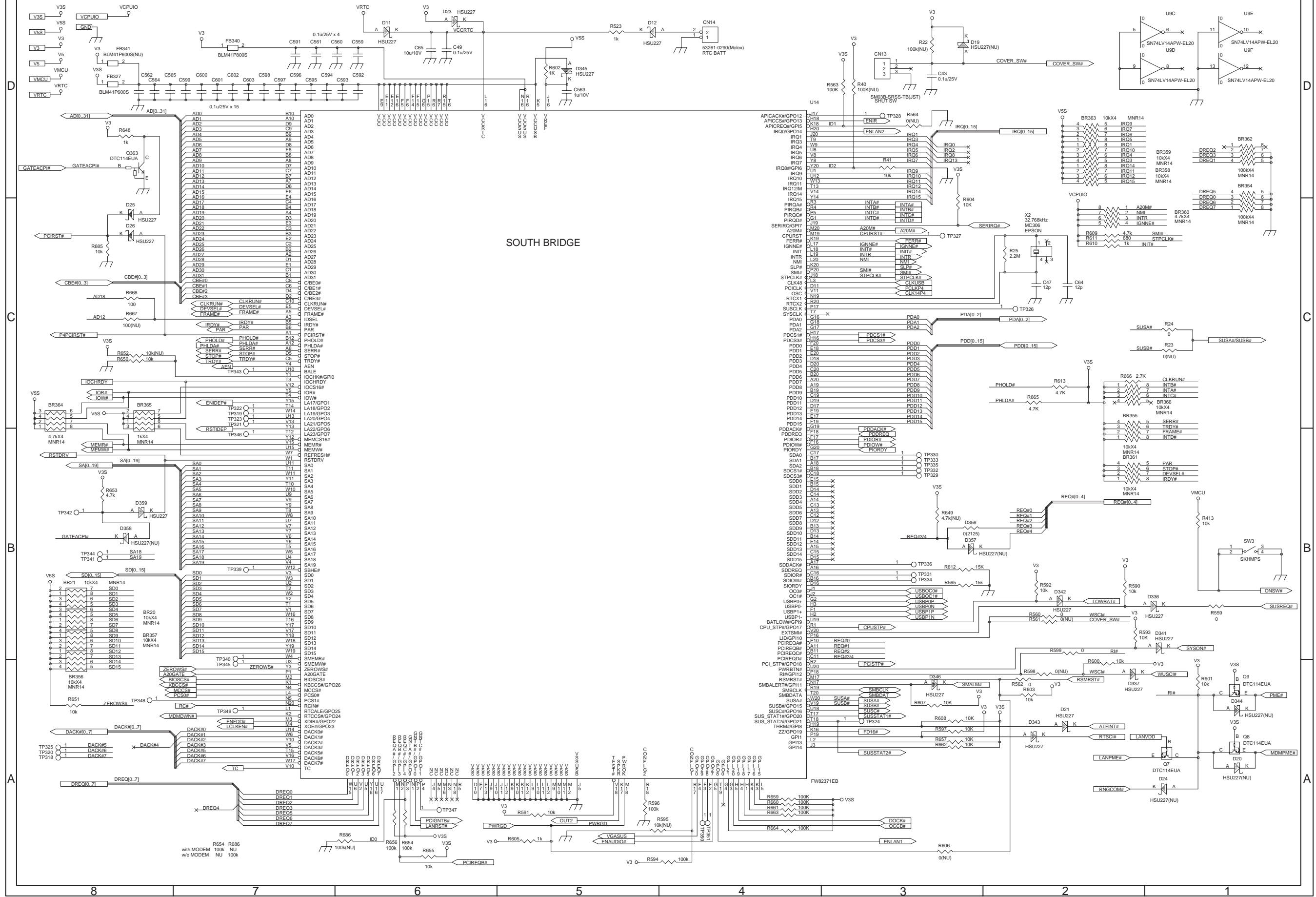



VIDEO CONTROLLER (REV 1.0)

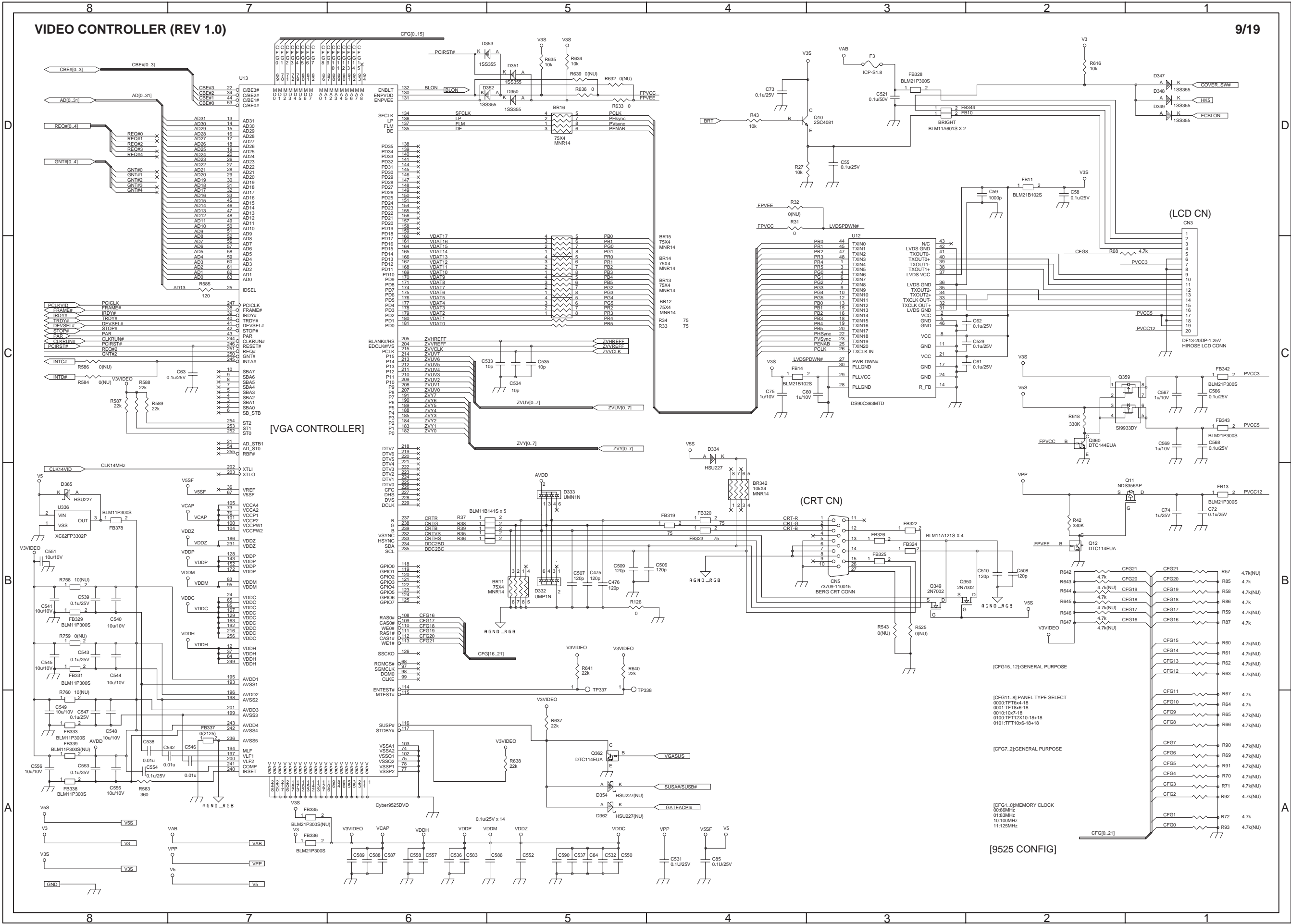

IDE/USB INTERFACE (REV 1.0)

IDE port

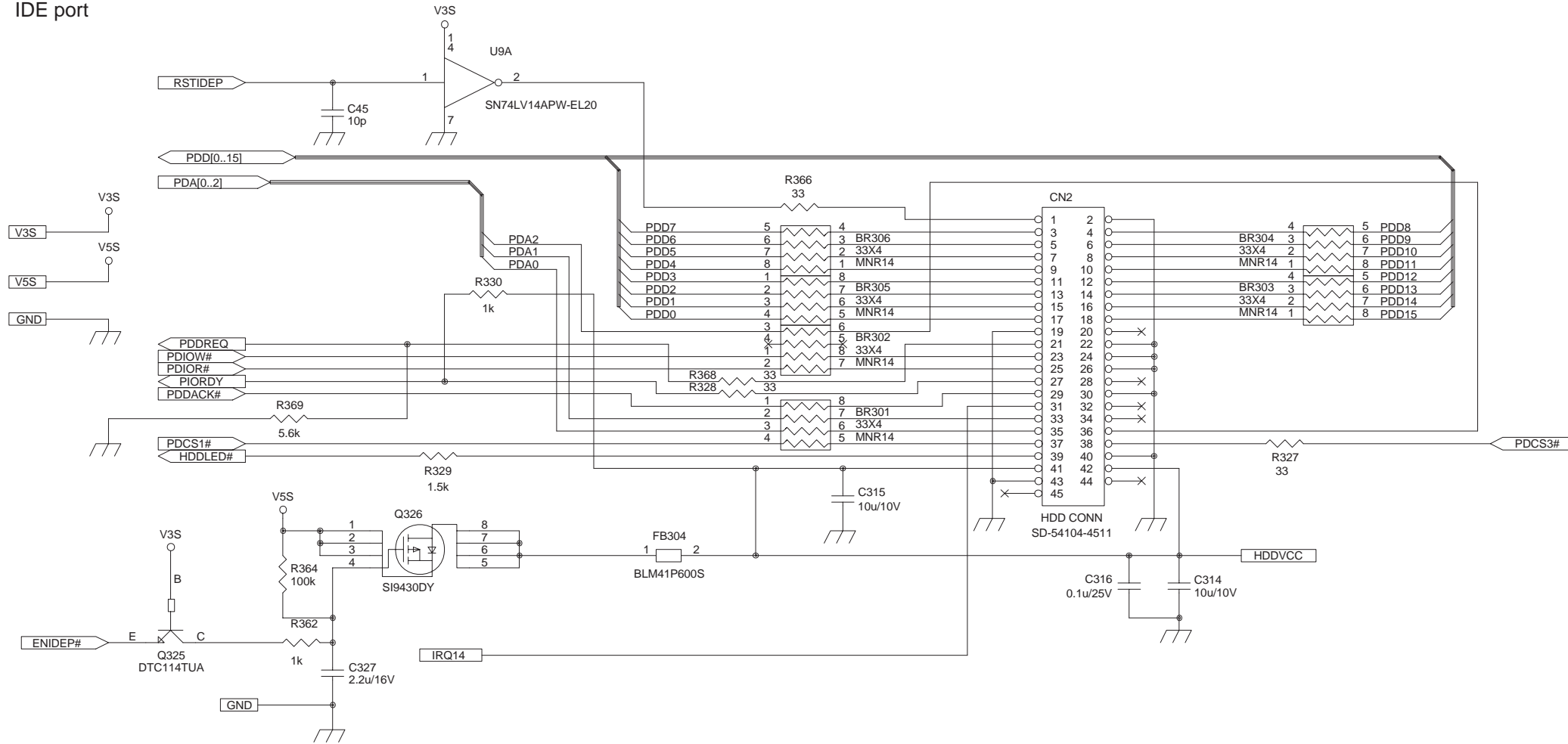

USB port

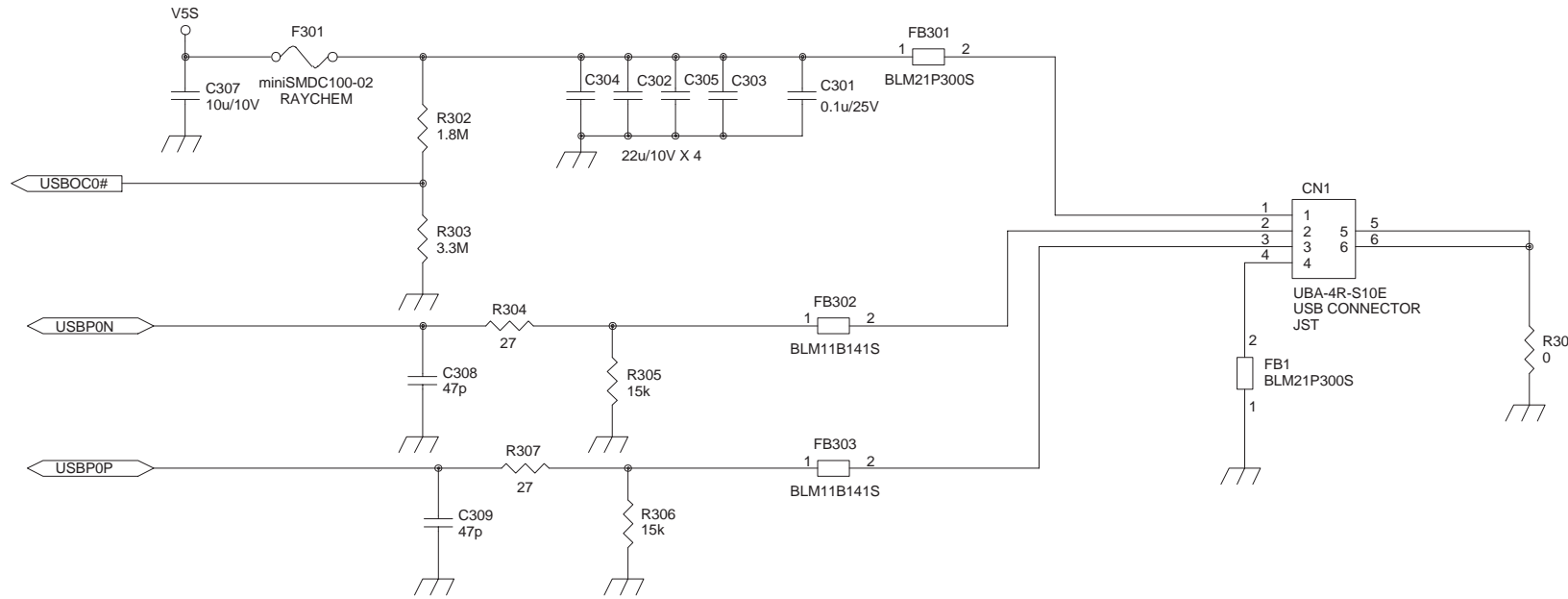

SUPER I/O (REV 1.0)

11/19

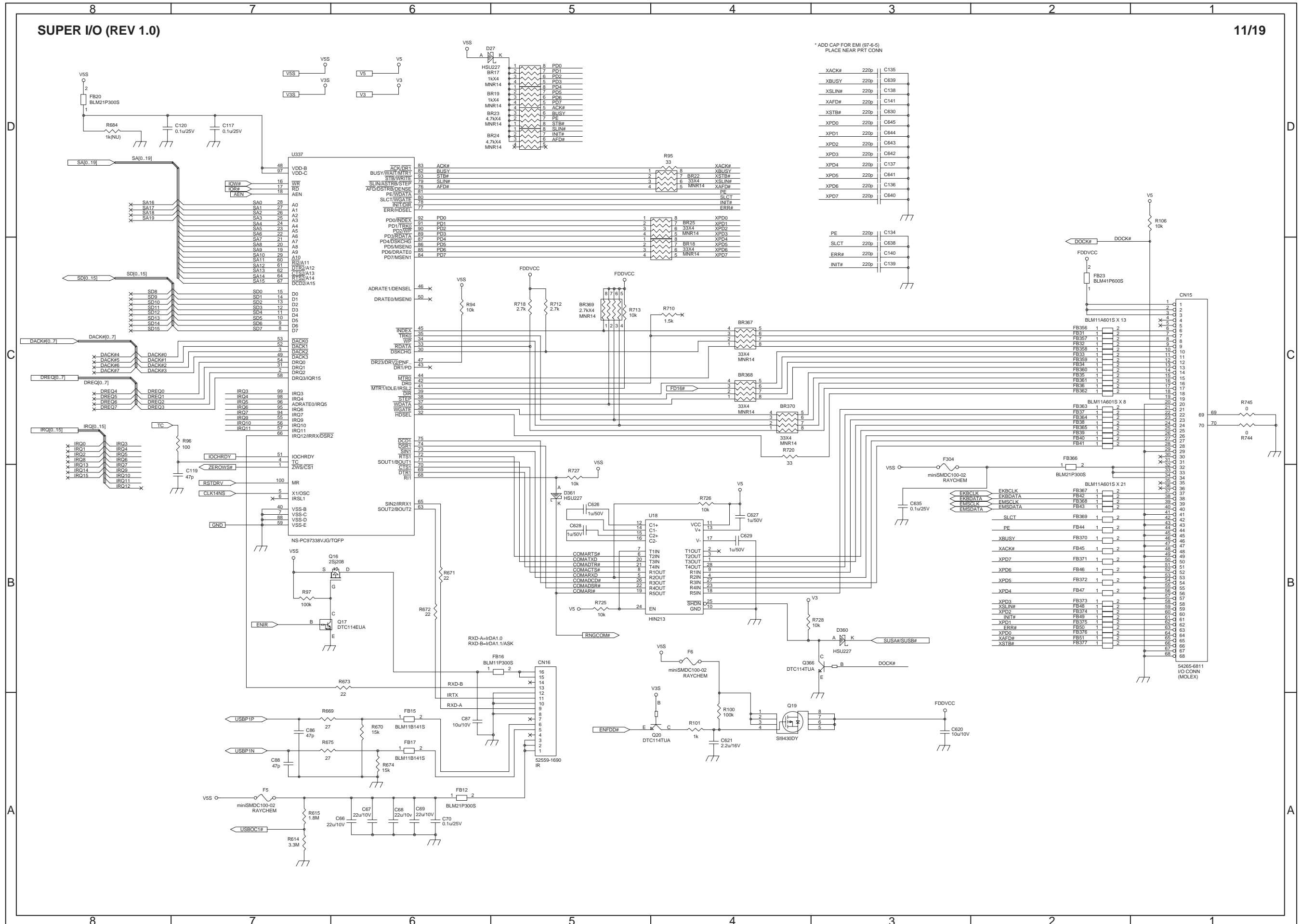

BIOS AND KEYBOARD CONT. (REV 1.0)

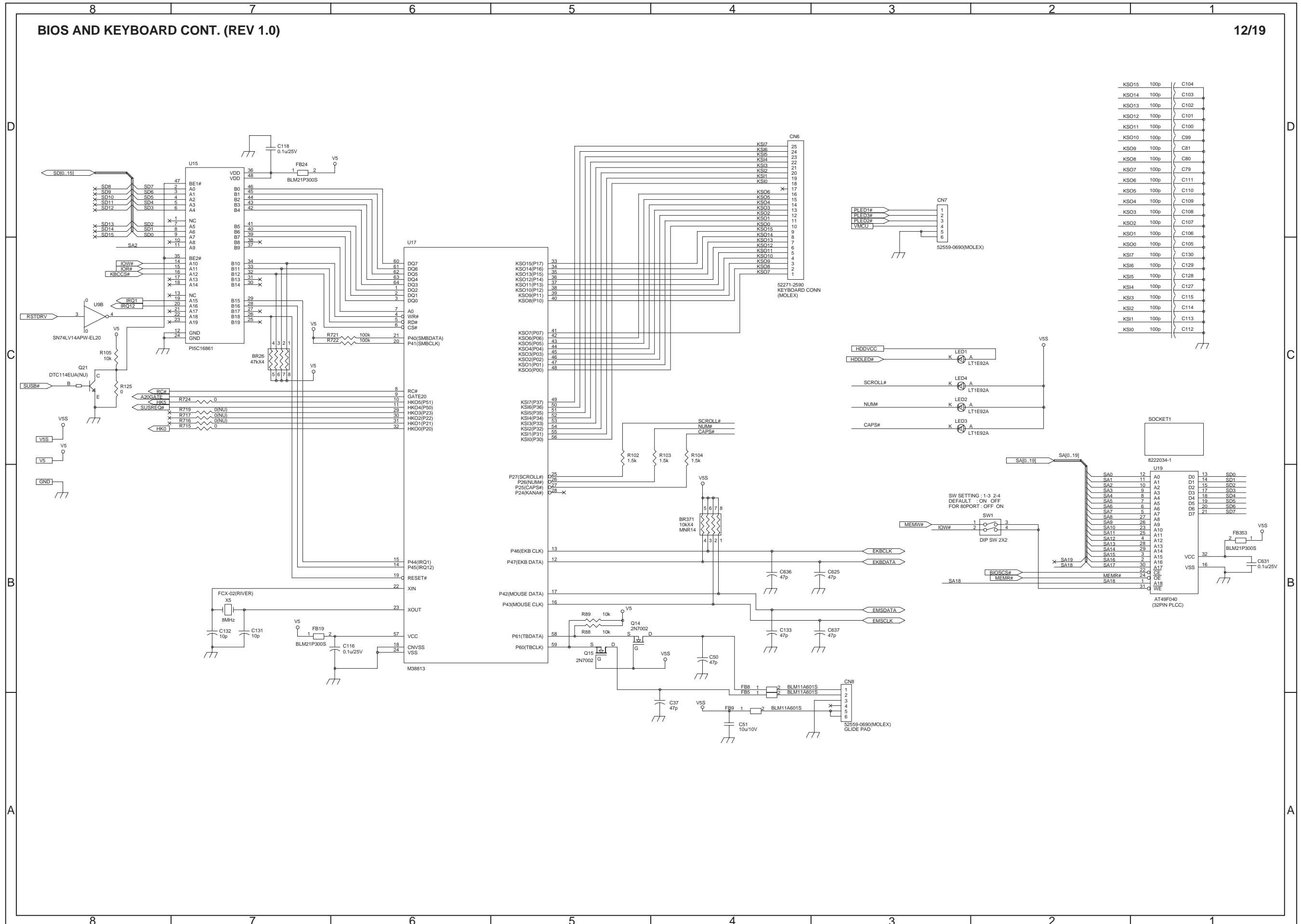

AUDIO (REV 1.0)

13/19

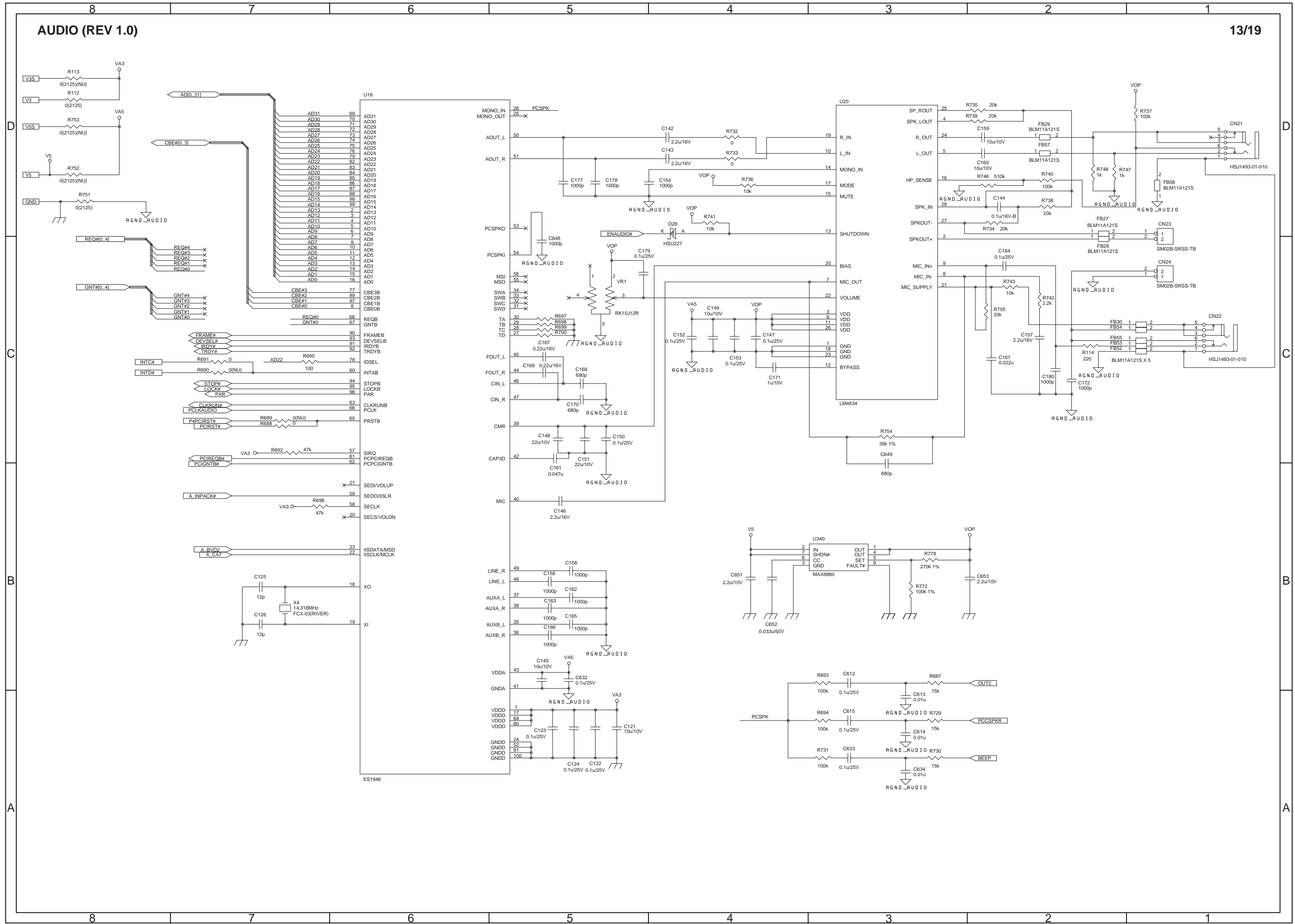

MODEM (REV 1.0)

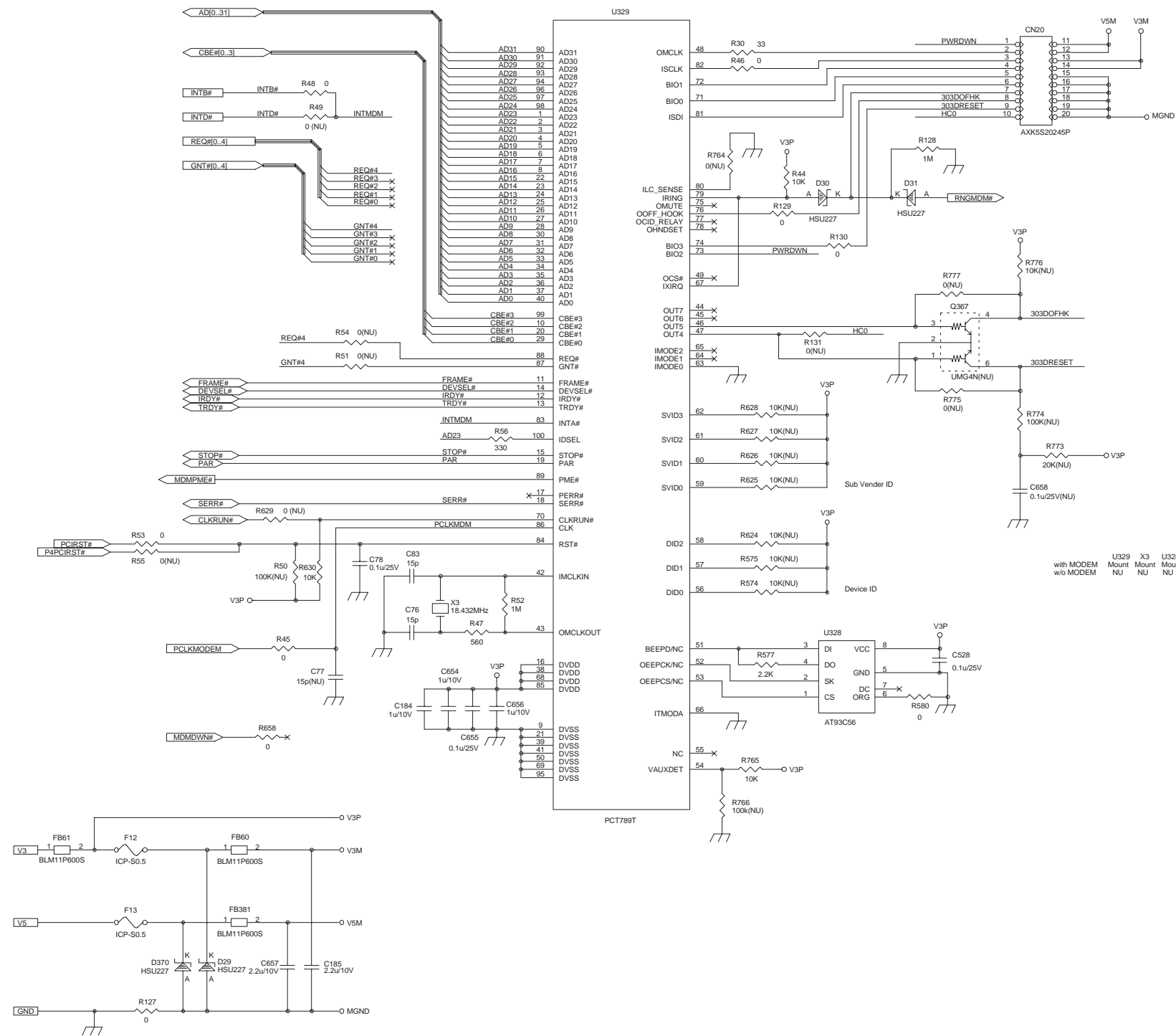





MCU H8/3434 (REV 1.0)

17/19

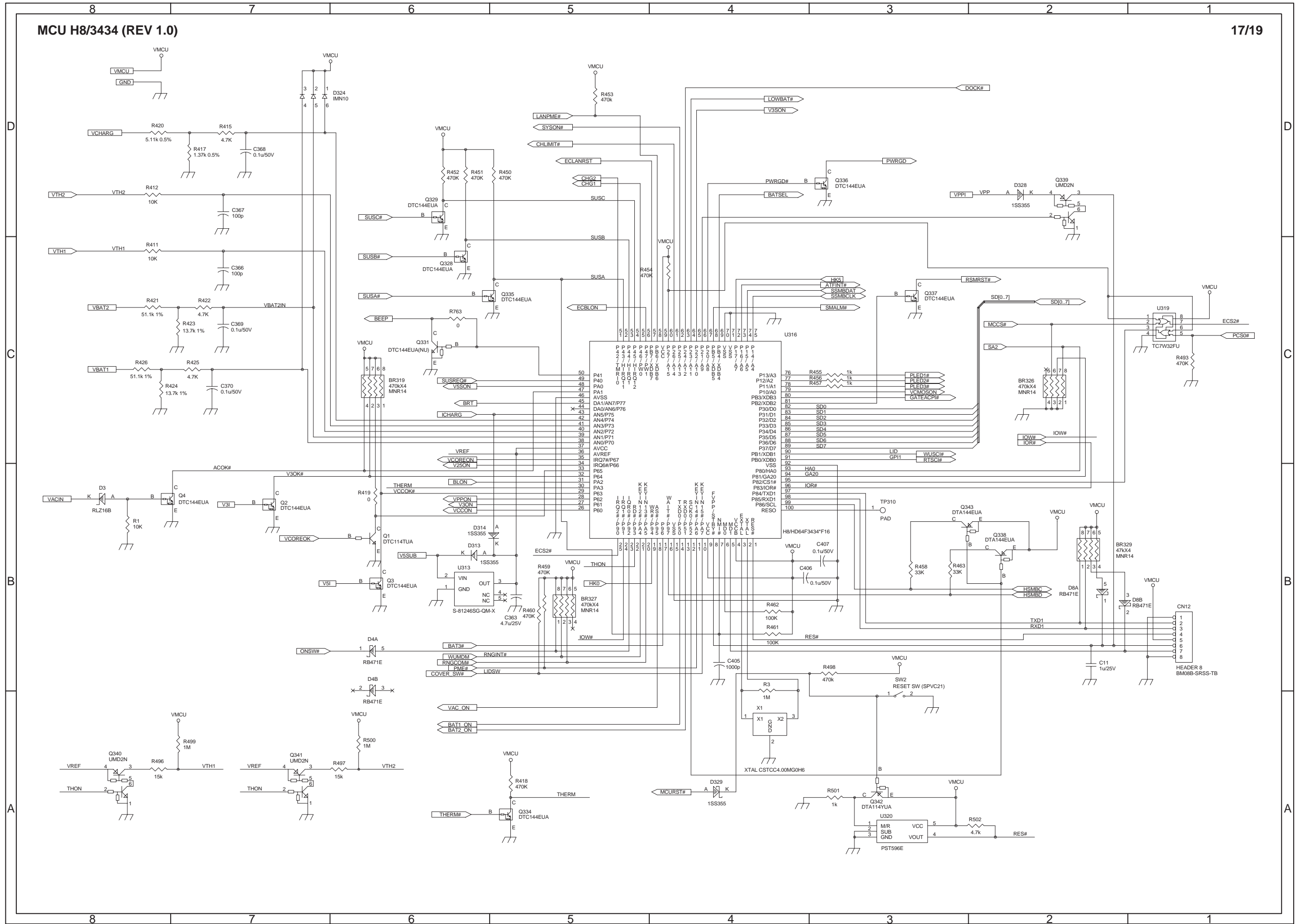

DC/DC (REV 1.0)

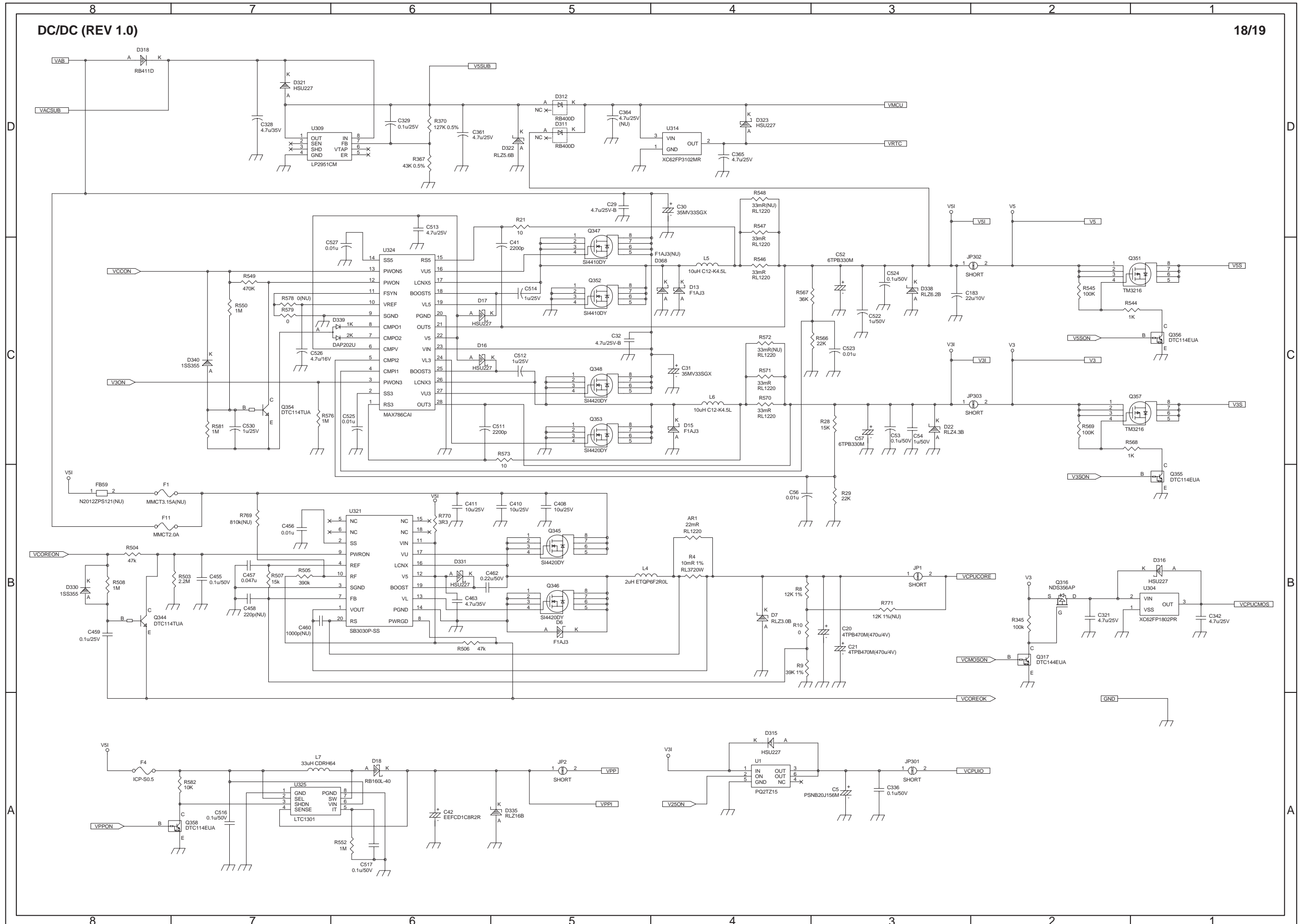

BATTERY CHARGER (REV 1.0)

19/19

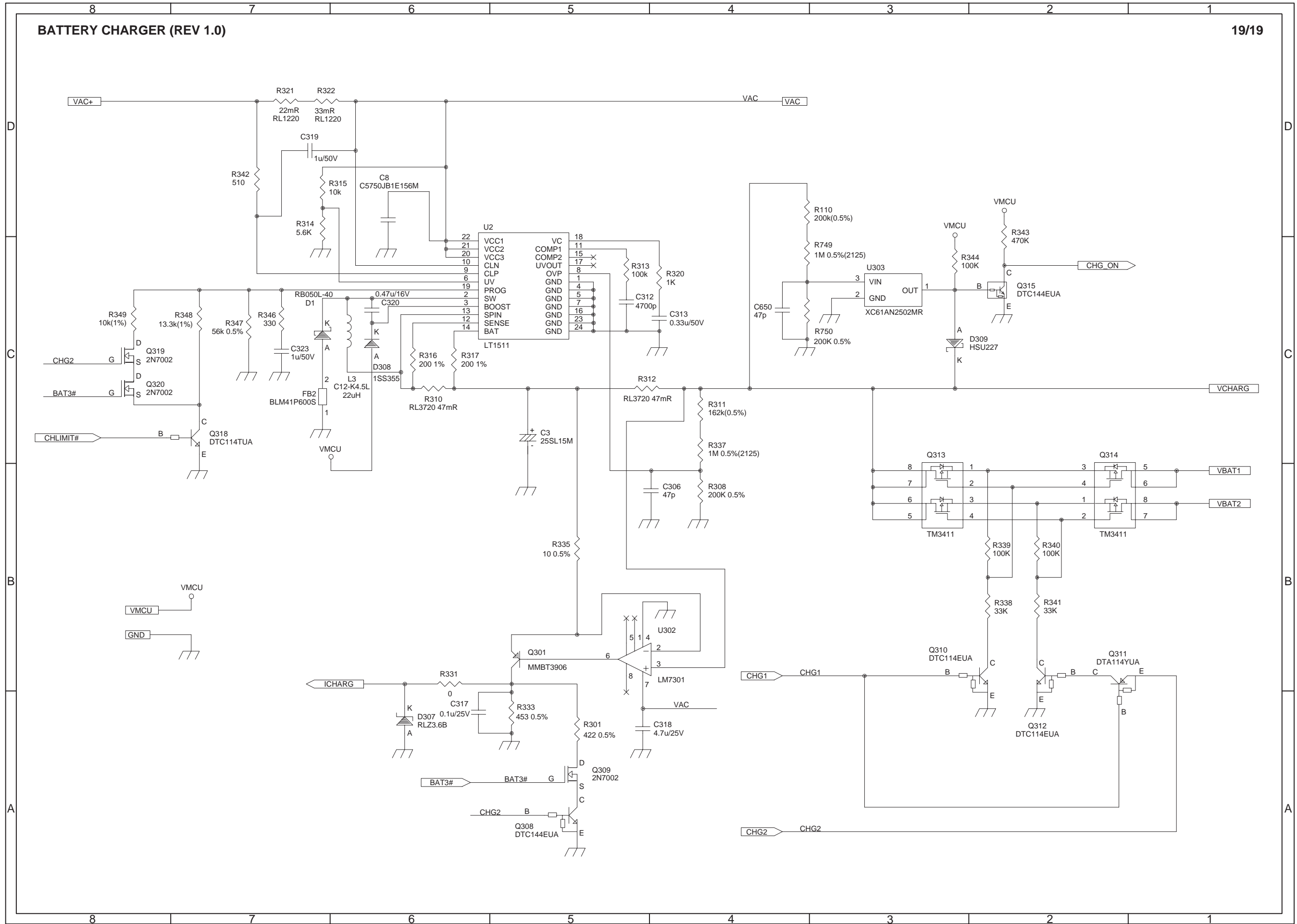

SIGNAL	PAGES
A_BVD2	8, 13
A_CA7	8, 13
A_INPACK#	8, 13
A20GATE	7, 12
A20M#	2, 3, 7
AD (0..31)	2, 5, 7, 8, 9, 13, 14, 15
ADS#	3, 5
AEN	7, 11
ATFINT#	7, 16, 17
BAT	17
BAT1_ON	17
BAT2_ON	17
BAT3#	17, 19
BATSEL	17
BEEP	13, 16, 17
BIOSCS#	7, 12
BLON	9, 16, 17
BNR#	3, 5
BPRI#	3, 5
BREQ0#	3, 5
BRT	9, 16
CBE# (0..3)	2, 5, 7, 8, 9, 13, 14, 15
CHG_ON	19
CHG1	17, 19
CHG2	17, 19
CHLIMIT#	17, 19
CKE (0..3)	5, 6
CLK14NS	2, 4, 11
CLK14P4	2, 4, 7
CLK14VID	2, 4, 9
CLKRUN#	2, 5, 7, 8, 9, 13, 14, 15
CLKUSB	2, 4, 7
COVER_SW#	7, 9, 16, 17
CPURST#	3, 5
CPUSTP#	2, 4, 7
CRESET#	3, 5
CSA# (0..3)	5, 6
DACK# (0..7)	7, 11
DBSY#	3, 5
DEFER#	3, 5
DEVSEL#	2, 5, 7, 8, 9, 13, 14, 15
DOCK#	7, 11, 16, 17
DQMA (0..7)	5, 6
DRDY#	3, 5
ECBLON	9, 16, 17
ECLANRST	15, 16, 17
EKBCLK	11, 12
EKBDATA	11, 12
EMSCLK	11, 12
EMSDATA	11, 12
ENAUDIO#	7, 13
ENFDD#	7, 11

SIGNAL	PAGES
ENIDEP#	7, 11
ENIR	7, 11
ENLAN1	7, 15
ENLAN2	7, 15
FD16#	7, 11
FERR#	2, 3, 7
FRAME#	2, 5, 7, 8, 9, 13, 14, 15
GATEACPI#	7, 9, 16, 17
GNT (0..4)	2, 5, 8, 9, 13, 14, 15
HA# (3..31)	3, 5
HCLK0	3, 4, 5
HD# (0..63)	3, 5
HDDLED#	10, 12
HIT#	3, 5
HI™ #	3, 5
HK0	12, 16, 17
HK5	9, 12, 16, 17
HLOCK#	3, 5
HREQ# (0..4)	3, 5
HSMBC	17
HSMBD	17
HTRDY#	3, 5
ICHARG	17, 19
IGNNE#	2, 3, 7
INIT#	2, 3, 7
INTB#	15
INTC#	9
INTD#	9, 15
INTR	2, 3, 7
IOR#	7, 11, 12, 16, 17
IOW#	7, 11, 12, 16, 17
IRDY#	2, 5, 7, 8, 9, 13, 14, 15
IRQ1	12
IRQ12	12
KBCCS#	7, 12
LANPME#	7, 15, 16, 17
LANRST#	7, 15
LCLKEN#	7, 15
LOCK#	2, 5, 13
LOWBAT#	7, 16, 17
MAB (0..13)	5, 6
MCCS#	7, 16, 17
MCURST#	17
MD (0..63)	5, 6
MDMDWN#	7, 14
MDMPME#	7, 14
MEMR#	7, 12
MEMW#	7, 12
NMI	2, 3, 7
OCCB#	7, 8
ONSW#	7, 16, 17
OUT2	7, 13

SIGNAL	PAGES
P4PCIRST#	2, 5, 7, 8, 13, 14, 15
PAR	2, 5, 7, 8, 9, 13, 14, 15
PCCSPKR	8, 13
PCIGNTB#	7, 13
PCIREQB#	7, 13
PCIRST#	7, 8, 9, 13, 14, 15
PCISTP#	2, 4, 7
PCLK440DX	4, 5
PCLKAUDIO	2, 4, 13
PCLKCB	2, 4, 8
PCLKLAN	2, 4, 15
PCLKMODEM	2, 4, 14
PCLKP4	2, 4, 7
PCLKVID	2, 4, 9
PCS0#	7, 16, 17
PDA (0..2)	7, 10
PDCS1#	7, 10
PDCS3#	7, 10
PDD (0..15)	7, 10
PDDACK#	7, 10
PDDREQ	7, 10
PDIOR#	7, 10
PDIOW#	7, 10
PHLDA#	2, 5, 7
PHOLD#	2, 5, 7
PIORDY	7, 1
PLED1#	12, 16, 17
PLED2#	12, 16, 17
PLED3#	12, 16, 17
PME#	7, 8, 16, 17
PWRGD	2, 3, 5, 7, 16, 17
RC#	7, 12
RNGCOM#	7, 11, 16, 17
RNGMDM#	14
RS# (0..2)	3, 5
RSMRST#	7, 16, 17
RSTDRV	7, 11, 12
RSTIDEP	7, 10
RTSCI#	7, 16, 17
SA (0..19)	7, 11, 12
SA2	16, 17
SCASA#	5, 6
SD (0..15)	7, 11, 12
SD (0..7)	16, 17
SDCLK (0..3)	4, 6
SDCLKREF	4, 5
SERIRQ#	7, 8
SERR#	2, 5, 7, 8, 14, 15
SLP#	2, 3, 7
SMALM#	7, 16, 17
SMBCLK	2, 4, 7
SMBDAT	2, 4, 7

SIGNAL	PAGES
SMI#	2, 3, 7
SRASA#	5, 6
SSMBCLK	2, 3, 16, 17
SSMBDAT	2, 3, 16, 17
STOP#	2, 5, 7, 8, 9, 13, 14, 15
STPCLK#	2, 3, 7
SUSA#	7, 16, 17
SUSA#/SUSB#	2, 4, 7, 9, 11
SUSB#	7, 12, 16, 17
SUSC#	7, 16, 17
SUSREQ#	7, 12, 16, 17
SUSSTAT1#	2, 5, 7
SUSSTAT2#	7, 8
SYSON#	7, 16, 17
TC	7, 11
THERM#	2, 3, 16, 17
TRDY#	2, 5, 7, 8, 9, 13, 14, 15
USBOC0#	7, 10
USBOC1#	7, 11
USBP0N	7, 10
USBP0P	7, 10
USBP1N	7, 11
USBP1P	7, 11
V25ON	17, 18
V3ON	17, 18
V3SON	17, 18
VAC_ON	17
VCCON	17, 18
VCMOSON	17, 18
VCOREOK	17, 18
VCOREON	17, 18
VGASUS	7, 9
V5SON	17, 18
VMCU	12
VPPON	17, 18
VTH1	17
VTH2	17
WEA#	5, 6
WUMDM	16, 17
WUSCI#	7, 16, 17
ZEROWS#	7, 11
ZVHREFF	8, 9
ZVUV (0..7)	8, 9
ZVVCLK	8, 9
ZVVREFF	8, 9
ZVY (0..7)	8, 9

MODEM DAA

1/1

Upper Board

Lower Board

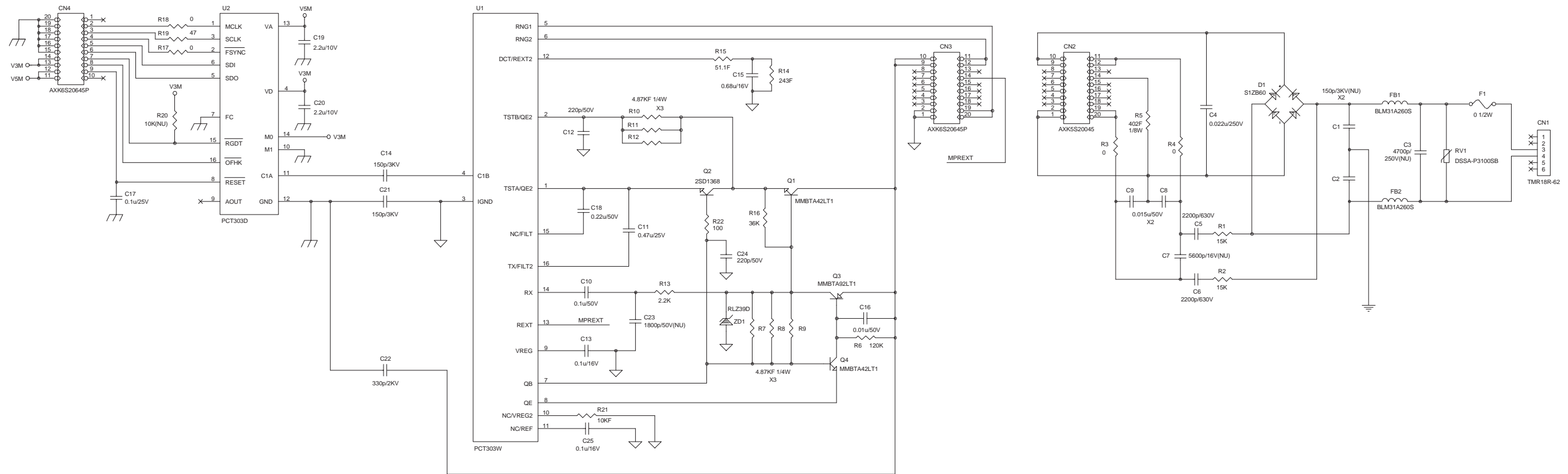

Secondary

Primary

EXT. MEMORY BOARD

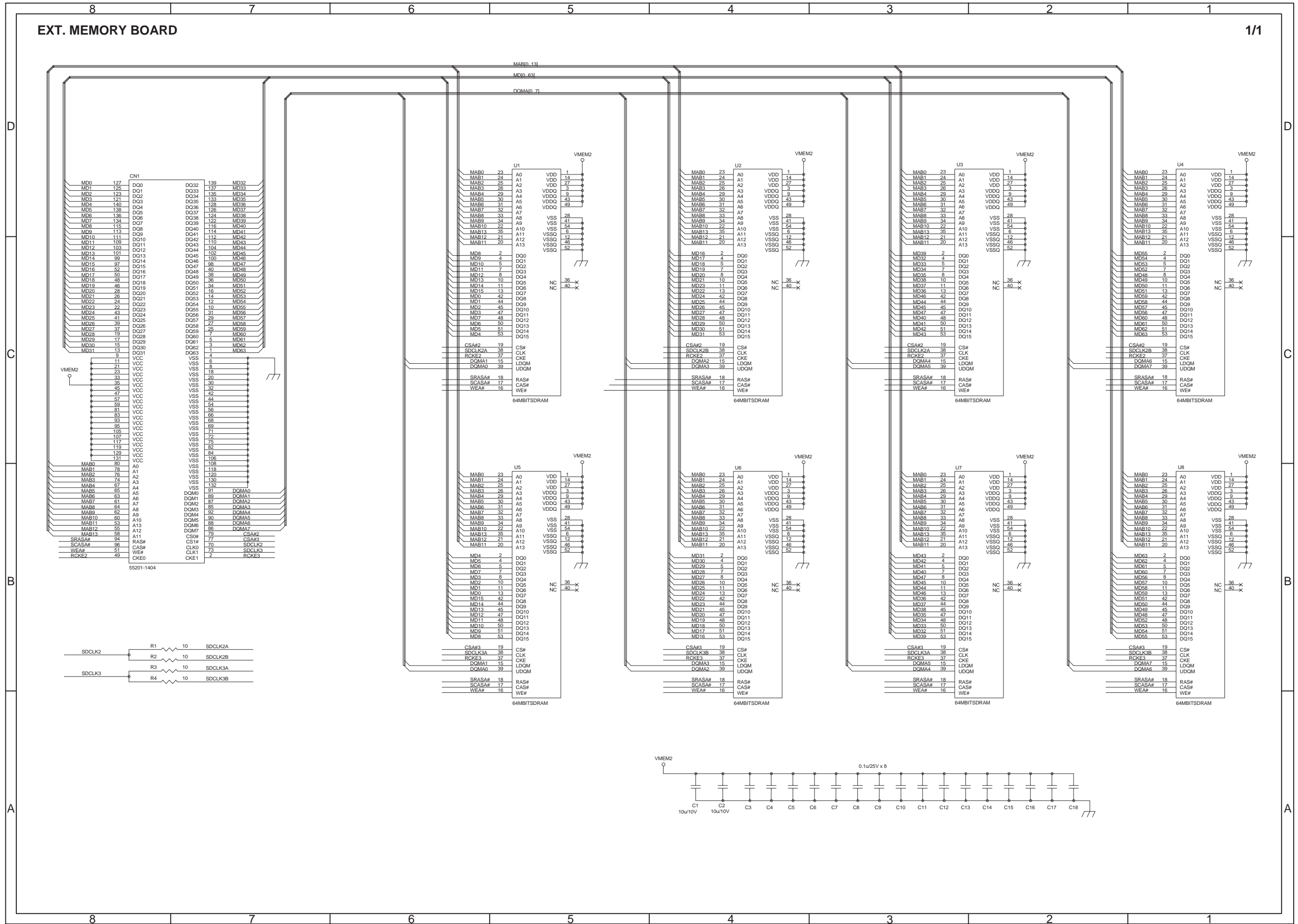

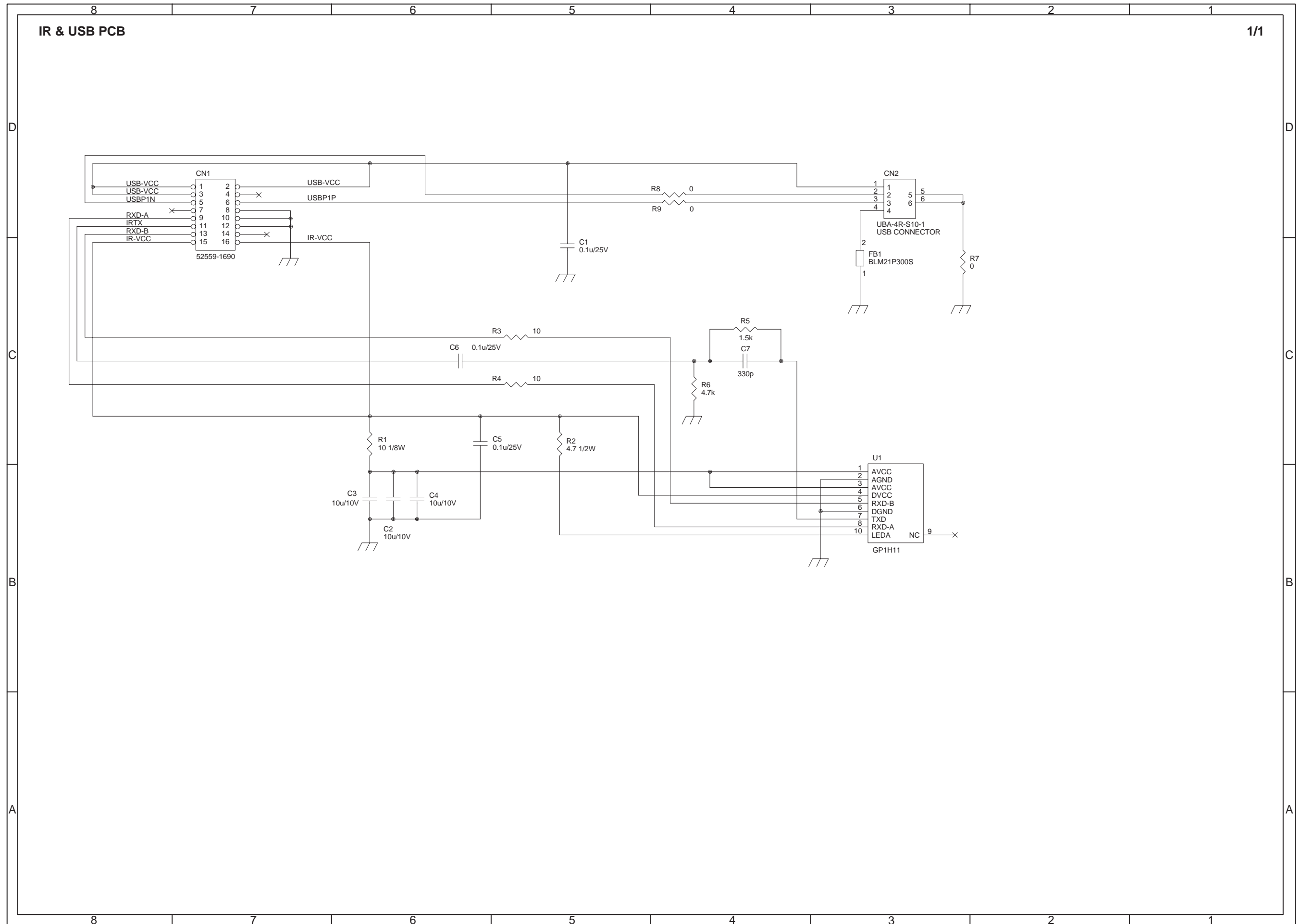

IR & USB PCB

1/1

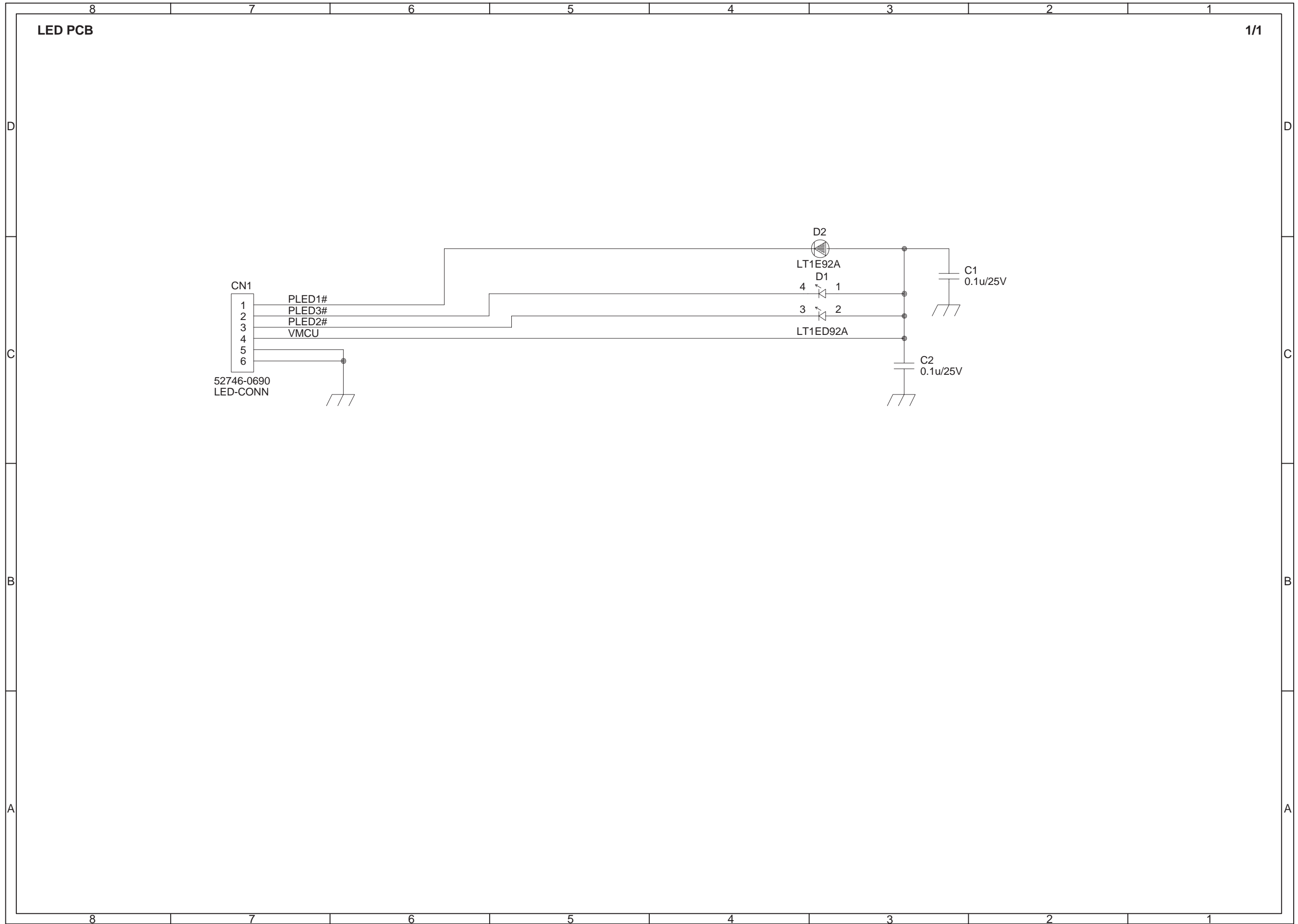

PARTS LAYOUT  
(SIDE A)

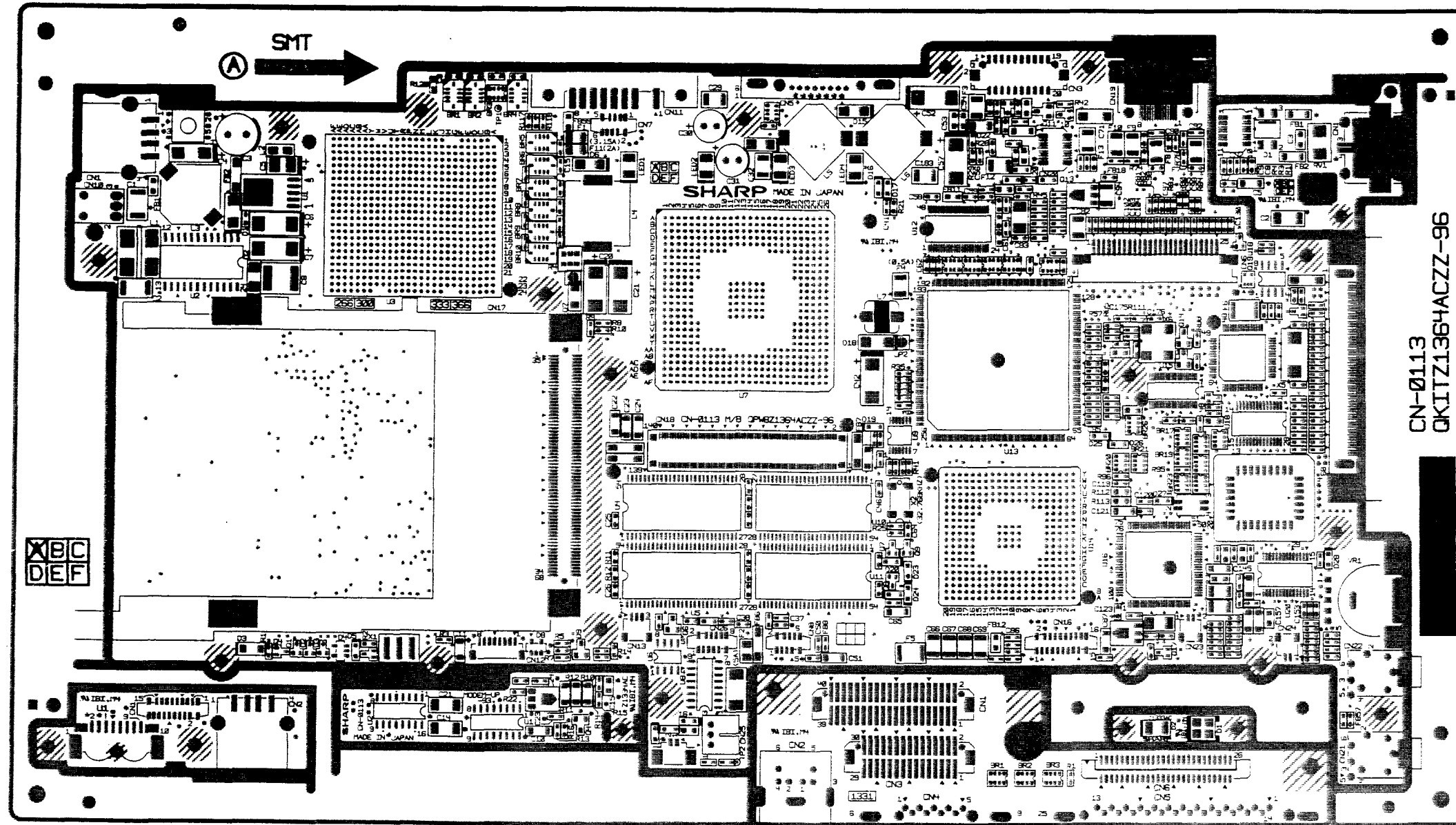

PARTS LAYOUT  
(SIDE B)

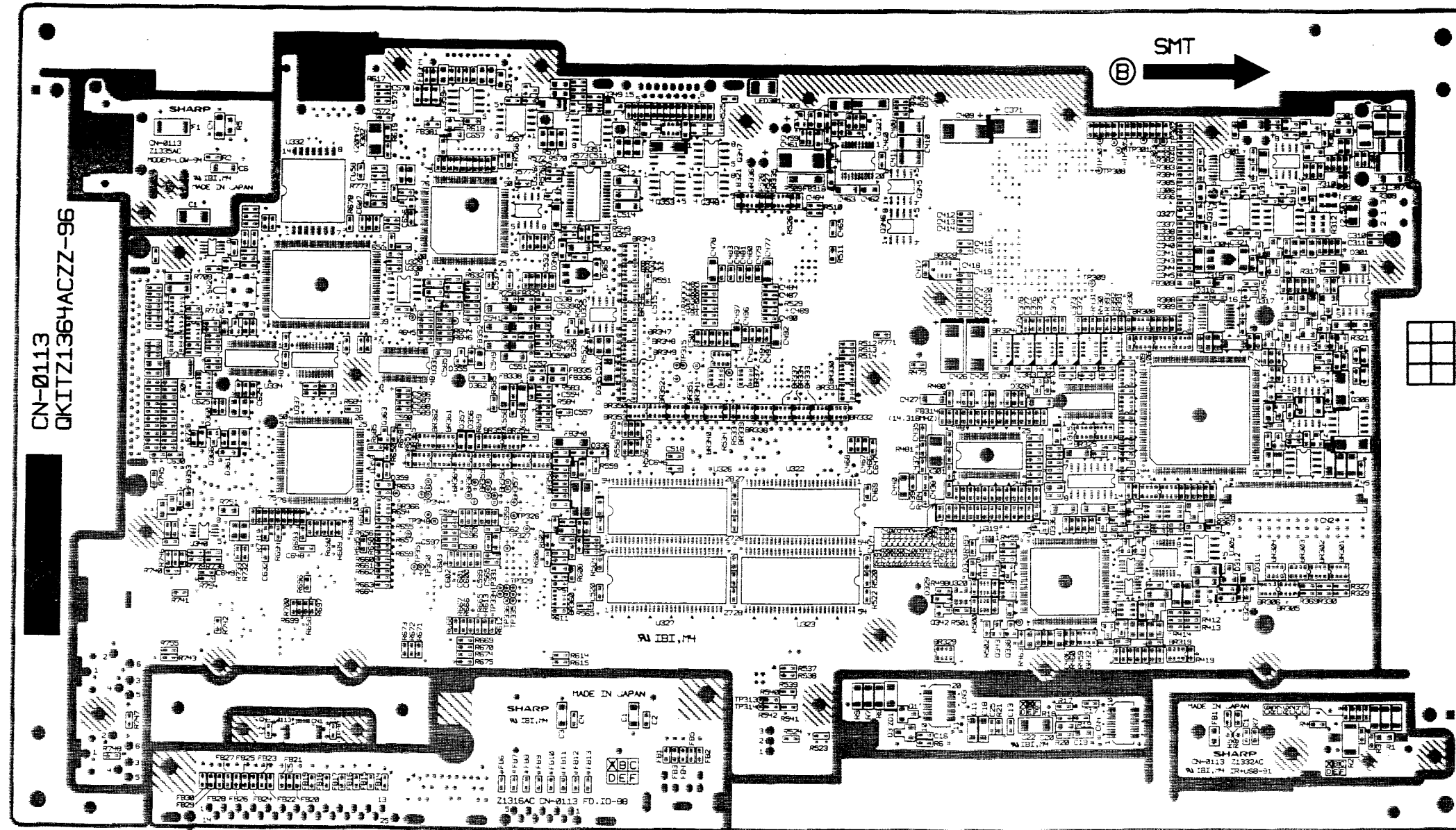

# SHARP

**COPYRIGHT © 2000 BY SHARP CORPORATION**

All rights reserved.

Printed in Japan.

No part of this publication may be reproduced,  
stored in a retrieval system, or transmitted.

In any form or by any means,  
electronic, mechanical, photocopying, recording, or otherwise,  
without prior written permission of the publisher.

**SHARP CORPORATION**  
**Information Systems Group**  
**Quality & Reliability Control Center**  
**Yamatokoriyama, Nara 639-1186, Japan**

2000 January Printed in Japan (t)