

*NEC Versa<sup>®</sup> LX Notebook Computer*

# VERSA LX

S E R V I C E   A N D   R E F E R E N C E  
M A N U A L

**NEC**

NEC Computer Systems Division  
Packard Bell NEC, Inc.

## Proprietary Notice and Liability Disclaimer

The information disclosed in this document, including all designs and related materials, is the valuable property of NEC Computer Systems Division, Packard Bell NEC, Inc. (hereinafter "NEC CSD") and/or its licensors. NEC CSD and/or its licensors, as appropriate, reserve all patent, copyright and other proprietary rights to this document, including all design, manufacturing, reproduction, use, and sales rights thereto, except to the extent said rights are expressly granted to others.

The NEC CSD product(s) discussed in this document are warranted in accordance with the terms of the Warranty Statement accompanying each product. However, actual performance of each such product is dependent upon factors such as system configuration, customer data, and operator control. Since implementation by customers of each product may vary, the suitability of specific product configurations and applications must be determined by the customer and is not warranted by NEC CSD.

To allow for design and specification improvements, the information in this document is subject to change at any time, without notice. Reproduction of this document or portions thereof without prior written approval of NEC CSD is prohibited.

FaxFlash is a service mark of NEC Computer Systems Division (NEC CSD), Packard Bell NEC, Inc.

NEC is a registered trademark of NEC Corporation, used under license.

ENERGY STAR is a U.S. registered mark.

All other product, brand, or trade names used in this publication are the trademarks or registered trademarks of their respective trademark owners.

First Printing — March 1999

Copyright 1999  
NEC Computer Systems Division  
Packard Bell NEC, Inc.  
1 Packard Bell Way  
Sacramento, CA 95828-0903  
All Rights Reserved

---

## Contents

Preface .....	vii
Abbreviations.....	ix

### Chapter 1 System Overview

Getting to Know the NEC Versa LX.....	1-2
Around the Front of the System.....	1-3
LCD Panel .....	1-3
Status Panel .....	1-4
Keyboard Panel and Base Unit.....	1-5
Around the Back of the System.....	1-7
Around the Left Side of the System.....	1-8
Around the Right Side of the System .....	1-10
Around the Bottom of the System .....	1-12
Internal Components.....	1-12
Battery Pack .....	1-12
Hard Disk Drive .....	1-13
File Bay .....	1-13
VersaBay III .....	1-13
CPU Board .....	1-13
Audio Board .....	1-13
CMOS Battery .....	1-13
Bridge Battery .....	1-13
ChipSet .....	1-14

### Chapter 2 System Configuration and Setup

Power Sources for Your NEC Versa .....	2-2
Using the AC Adapter .....	2-2
Powering On .....	2-4
Using the Main Battery Pack.....	2-4
Determining Battery Status.....	2-5
When to Change the Battery .....	2-6
Battery Handling .....	2-7
Replacing the Battery.....	2-7
Battery Precautions .....	2-9
Recharging Battery Precautions.....	2-10
Extending Battery Life.....	2-10
NEC VersaBay III Battery.....	2-10
Internal Batteries .....	2-10
CMOS Battery .....	2-10
Bridge Battery .....	2-11
BIOS Setup .....	2-11
How to Enter the BIOS Setup .....	2-11
BIOS Setup Utility Main Menu .....	2-12
How to Use BIOS Setup.....	2-12
Looking at Screens.....	2-13
Using Keys.....	2-13
Checking/Setting System Parameters .....	2-14
BIOS Setup Menus .....	2-16
Standard CMOS Setup.....	2-16

Advanced CMOS Setup .....	2-17
System Security Setup.....	2-17
Power Management Setup.....	2-18
Boot Device Setup.....	2-19
Peripheral Setup .....	2-20
Other BIOS Setup Options .....	2-21
Password Protection .....	2-21
Using BIOS Setup to Set Power Management .....	2-21
Using the Save to File (STF) Feature .....	2-22
Updating the BIOS.....	2-22
Preparing the BIOS Upgrade Diskette .....	2-23
Changing the Switch Settings.....	2-24
Performing the BIOS Update .....	2-24
NEC CSD Utilities .....	2-25
NEC Customize Utility .....	2-25
Using the NEC Customize Utility .....	2-25
HDPREPEZ Utility.....	2-26
Using HDPREPEZ in Windows 95 and Windows 98.....	2-26
Using HDPREPEZ in Windows NT.....	2-26
Software Applications and Drivers .....	2-27
Using the Application and Driver CD .....	2-27
Launching the Application and Driver CD .....	2-27
Installing the Software.....	2-28
Partition Magic .....	2-28
Using Partition Magic .....	2-28
Intel LANdesk Client Manager.....	2-29
SystemSoft PowerProfiler.....	2-30
SystemSoft CardWizard .....	2-30
Intellisync 97 or Intellisync for Notebooks .....	2-30
McAfee VirusScan.....	2-31
Microsoft Internet Explorer .....	2-31
Netscape Navigator.....	2-31
Adobe Acrobat Reader.....	2-31
Enabling the IR Port .....	2-31
Windows 95 Systems .....	2-32
Windows NT Systems .....	2-32

### Chapter 3 Disassembly and Reassembly

Required Tools and Equipment.....	3-2
Disassembly .....	3-2
Battery.....	3-2
Removing a Device from the VersaBay III .....	3-4
Keyboard, Memory Module, Switch Settings.....	3-5
Switch Settings for Non-AGP Models .....	3-7
Switch Settings for AGP Models .....	3-7
Changing Switch Settings .....	3-8
Disassembly Differences .....	3-9
Disassembly – User Replaceable Drive System .....	3-10
CPU Assembly.....	3-10
File Bay Assembly.....	3-11
Hard Disk Drive Assembly.....	3-12

Front Cover.....	3-13
Speaker Assembly, VersaGlide Assembly, LCD Panel Latch Switch Assembly.....	3-14
VersaGlide Assembly .....	3-14
LCD Panel Switch Board.....	3-15
LCD Panel Assembly .....	3-15
LED Sub Assembly.....	3-16
PC Card Assembly, CMOS Battery, Buzzer, and Audio Board.....	3-17
PC Card Assembly .....	3-17
CMOS Battery .....	3-18
Buzzer .....	3-18
Main Board Assembly.....	3-18
Fan Assembly.....	3-18
CPU Assembly.....	3-19
Bracket/Insulator Assemblies, Bridge Battery, Power Switch.....	3-19
Connector Board, Switch/Cable Cover, Switch/Cable.....	3-19
Bottom Base Assembly .....	3-20
Disassembly – Non-User Replaceable Drive System.....	3-20
CPU Assembly .....	3-20
Front Cover.....	3-21
Speaker Assembly, VersaGlide Assembly, LCD Panel Latch Switch Assembly.....	3-23
VersaGlide Assembly .....	3-23
LCD Panel Switch Board.....	3-23
LCD Panel Assembly .....	3-24
LED Sub Assembly.....	3-25
Hard Drive and PC Card Assemblies, CMOS Battery, Buzzer, Audio Board.....	3-25
Hard Drive Assembly.....	3-26
PC Card Assembly .....	3-26
CMOS Battery .....	3-26
Buzzer .....	3-27
Main Board Assembly.....	3-27
Fan Assembly.....	3-27
CPU Assembly .....	3-27
Bracket/Insulator Assemblies, Bridge Battery, Power Switch.....	3-28
Connector Board, Switch/Cable Cover, Switch/Cable.....	3-28
Bottom Base Assembly .....	3-29
Reassembly.....	3-29

## Chapter 4 System Board Layout

Audio Board .....	4-2
Connector Board.....	4-2
LCD Panel Switch Board.....	4-3
LED Status Board.....	4-3
Main Board.....	4-4

## Chapter 5 Illustrated Parts Breakdown

Illustrated Parts Breakdown (Non-AGP Models) .....	5-2
Parts List (Non-AGP Models) .....	5-3
Illustrated Parts Breakdown (AGP Models).....	5-5
Parts List (AGP Models) .....	5-6

---

## Chapter 6 Preventive Maintenance

Cleaning the Notebook Exterior .....	6-2
Cleaning the Notebook Interior.....	6-2
Protecting the Disk Drives .....	6-2
Handling the Battery Pack .....	6-3
Maintaining the LCD Quality .....	6-4

## Chapter 7 Troubleshooting

Quick Troubleshooting .....	7-2
Helpful Questions .....	7-4

## Chapter 8 Getting Services and Support

Services and Support Contact Information .....	8-2
NEC CSD Web Site .....	8-2
NEC CSD FTP Site.....	8-3
Email/Fax to Support Services.....	8-3
NEC CSD Bulletin Board .....	8-4
NEC CSD Support Services.....	8-5
NEC CSD Customer Assistance Center.....	8-6

## Chapter 9 Specifications

System Components.....	9-2
Pin Assignments.....	9-7
Connector Locations .....	9-12
Memory Map.....	9-13
Interrupt Controllers.....	9-14

## Glossary

## Index

---

# Preface

This service and reference manual contains the technical information necessary to set up and maintain the NEC Versa<sup>®</sup> LX notebook computer.

The manual also provides hardware and interface information for users who need an overview of the system design. The manual is written for NEC-trained customer engineers, system analysts, service center personnel, and dealers.

The manual is organized as follows:

**Chapter 1**, System Overview, provides an overview of the hardware and interface components.

**Chapter 2**, System Configuration and Setup, provides information on setup and how to operate the notebook.

**Chapter 3**, Disassembly and Reassembly, provides detailed instructions on how to disassembly the notebook.

**Chapter 4**, System Board Layout, shows the system boards and the board connectors.

**Chapter 5**, Illustrated Parts Breakdown, shows the Illustrated Parts Breakdown (IPB) and corresponding part numbers.

**Chapter 6**, Preventive Maintenance, lists general notebook preventive maintenance procedures.

**Chapter 7**, Troubleshooting, lists troubleshooting procedures as well as helpful servicing hints.

**Chapter 8**, Getting Services and Support, provides information as to how to contact NEC CSD for service information, technical support, product information and ordering information from FaxFlash.

**Chapter 9**, Specifications, lists physical specifications, video modes, pin assignments, connector locations, memory map and interrupt controllers.

A **Glossary** and an **Index** are included for convenience.

---

# Abbreviations

A	ampere	DLAB	Divisor Latch Address bit
AC	alternating current	DMA	direct memory access
AGP	Advanced Graphics Port	DMAC	DMA controller
AT	advanced technology (IBM PC)	DOS	disk operating system
BBS	Bulletin Board Service	DRAM	dynamic RAM
BCD	binary-coded decimal	DVD	digital video disk
BCU	BIOS Customized Utility	ECC	error checking and correction
BIOS	basic input/output system	ECP	enhanced capabilities port
bit	binary digit	EDO	extended data output
BUU	BIOS Upgrade Utility	EGA	Enhanced Graphics Adapter
bpi	bits per inch	EPP	enhanced parallel port
bps	bits per second	EPROM	erasable and programmable ROM
C	capacitance	EVGA	Enhanced Video Graphics Array
C	centigrade	F	Fahrenheit
Cache	high-speed buffer storage	FAX	facsimile transmission
CAM	constantly addressable memory	FCC	Federal Communications Commission
CAS	column address strobe	FG	frame ground
CD-ROM	compact disk-ROM	FM	frequency modulation
CG	character generator	FP	fast page
CGA	Color Graphics Adapter	FRU	field-replaceable unit
CGB	Color Graphics Board	GB	gigabyte
CH	channel	GND	ground
clk	clock	HEX	hexadecimal
cm	centimeter	Hz	hertz
CMOS	complementary metal oxide semiconductor	IC	integrated circuit
COM	communication	ID	identification
CONT	contrast	IDE	intelligent device electronics
CPGA	ceramic pin grid array	IDTR	interrupt descriptor table register
CPU	central processing unit	in.	inch
DAC	digital-to-analog converter	INTA	interrupt acknowledge
DACK	DMA acknowledge	IPB	illustrated parts breakdown
DC	direct current	IR	infrared
DIP	dual in-line package		



---

IRR	Interrupt Request register	PDA	personal digital assistant
ISA	Industry Standard Architecture	PFP	plastic flat package
ISR	In Service register	PIO	parallel input/output
I/O	input/output	pixel	picture element
IPC	integrated peripheral controller	PLCC	plastic leaded chip carrier
ips	inches per second	PLL	phase lock loop
IRQ	interrupt request	p-p	peak-to-peak
K	kilo (1024)	PPI	programmable peripheral interface
k	kilo (1000)	PROM	programmable ROM
KB	kilobyte	QFP	quad flat pack
kg	kilogram	RAM	random-access memory
kHz	kilohertz	RAMDAC	RAM digital-to-analog converter
lb	pound	RAS	row address strobe
LED	light-emitting diode	RGB	red green blue
LCD	liquid crystal display	RGBI	red green blue intensity
LSB	least-significant bit	ROM	read-only memory
LSI	large-scale integration	rpm	revolutions per minute
M	mega	R	read
mA	milliamps	RTC	real-time clock
max	maximum	R/W	read/write
MB	megabyte	S	slave
MDA	Monochrome Display Adapter	SCSI	Small Computer System Interface
MFM	modified frequency modulation	SDRAM	synchronous dynamic random-access memory
MHz	megahertz	SG	signal ground
mm	millimeter	SIMM	single inline memory module
ms	millisecond	SPM	standard page mode
MSB	most-significant bit	SRS	Sound Retrieval System
NASC	National Authorized Service Center	SVGA	Super Video Graphics Array
NC	not connected	SW	switch
NMI	Non-maskable Interrupt	TFT	thin film transistor
ns	nanosecond	TSC	Technical Support Center
NSRC	National Service Response Center	TTL	transistor/transistor logic
PAL	programmable array logic	tpi	tracks per inch
PCB	printed circuit board	USB	universal serial bus
PCI	Peripheral Component Interconnect	V	volt
		Vac	volts, alternating current
		Vdc	volts, direct current

---

---

VESA	video electronics standards association
VFC	VESA-compliant feature connector
VGA	Video Graphics Array
VRAM	video RAM
W	watt
W	write
XGA	Extended Graphics Array

# 1

## System Overview

- Getting to Know the NEC Versa LX
- Around the Front of the System
- Around the Back of the System
- Around the Left Side of the System
- Around the Right Side of the System
- Around the Bottom of the System
- Internal Components

---

## ***Getting to Know the NEC Versa LX***

The NEC Versa LX notebook computer is a portable system filled with exciting resources for home, business or travel. Standard features include a powerful Intel® Pentium 200-MHz or 233-MHz, or Pentium II 233-MHz, 266-MHz, 300-MHz, 300-PE, 333-MHz, 366-MHz, or 400-MHz microprocessor that works together with the latest Peripheral Component Interconnect (PCI) architecture. Some systems also include Advanced Graphics Port (AGP) support.

In addition, the system provides a high-performance hard disk drive, a diskette drive or SuperDisk™ drive, and PC card support. Most models are equipped with a 24X CD-ROM drive, or a DVD-ROM drive. As a multimedia system, the NEC Versa also provides the tools needed to create and present impressive images using video clips and sound.

### ***NEC Versa LX notebook computer***



To get comfortable with the notebook, read the following sections and take a tour around the system!

---

## ***Around the Front of the System***

The NEC Versa is compact with features on every side. First, look at the front of the NEC Versa. The following sections describe front features, beginning with the liquid crystal display (LCD) panel.

### ***LCD Panel***

The NEC Versa LX comes with a color LCD panel that can be adjusted for a comfortable viewing position. Depending on the model, the system is equipped with a:

- 12.1-inch color Thin Film Transistor (TFT) Super Video Graphics Array (SVGA) panel.
- 13.3-inch color Thin Film Transistor (TFT) Extended Graphics Array (XGA) panel.
- 14.1-inch Thin Film Transistor (TFT) Extended Graphics Array (XGA) panel.

To adjust the LCD panel brightness:

- Use the slide switch on the front of the panel (12.1-inch TFT, SVGA panel only).
- Press the **Fn-F8** and **Fn-F9** function keys.

In addition to the superior display panel, the NEC Versa is equipped with a Pentium II processor with AGP. AGP adds new features for graphics accelerators such as dedicated access to main memory and faster transfer rates. AGP further expands current 3D capabilities to new levels of visual realism providing higher performance 3D graphics capabilities.

---

## Status Panel

The NEC Versa status panel provides the features shown in the figure. These features are described after the figure.

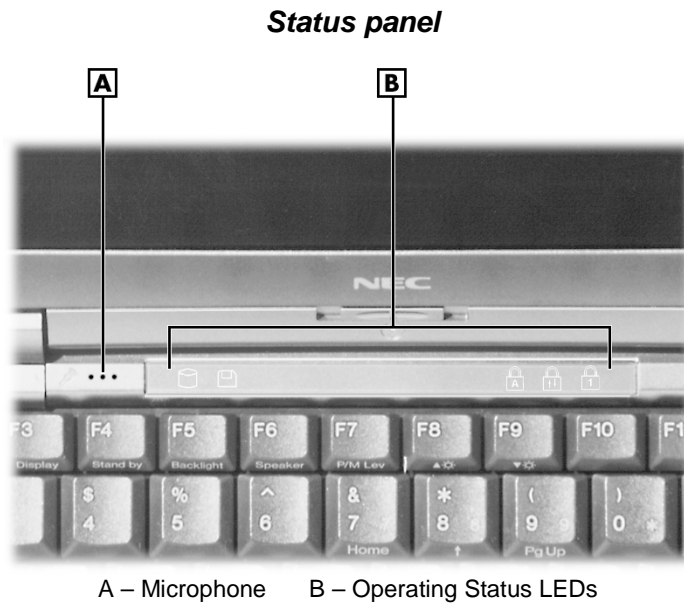

- Microphone — A strategically positioned built-in microphone allows the user to record monophonic sound directly into the notebook computer.
- Operating Status LEDs — informs users of the NEC Versa's current operating status. See the following figure and list for each icon's meaning.

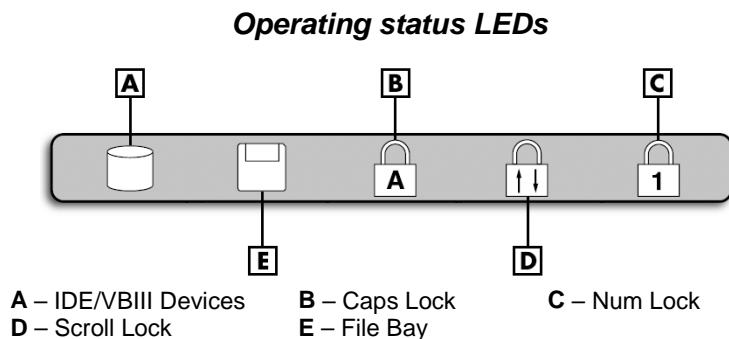

- IDE/VBIII devices — lights when the NEC Versa writes data to or retrieves data from the internal hard disk drive or a device in the VersaBay III.
- Caps Lock — lights when Caps Lock mode is in effect.
- Num Lock — lights when Num Lock mode is active.
- Scroll Lock — lights when Scroll Lock mode is in effect.

---

— File Bay — lights when the NEC Versa accesses either the floppy disk drive or SuperDisk drive installed in the file bay.

## **Keyboard Panel and Base Unit**

The NEC Versa keyboard panel and base unit contain the following features which are described after the figure.

**Keyboard panel and base unit**



**A** – Stereo Speaker                      **B** – VersaGlide                      **C** – Keyboard  
**D** – System Power Status LEDs      **E** – VersaBay III

- Stereo Speakers — provide stereo sound for multimedia presentations or listening pleasure. The built-in sound system also supports 3D sound, which simulates the latest surround-sound technology.
- NEC VersaGlide — The NEC VersaGlide works like a standard computer mouse. Simply move your fingertip over the VersaGlide to control the position of the cursor. Use the left button below the VersaGlide to select menu items.
- Keyboard — 85 keys with the standard QWERTY-key layout. (Models purchased outside of the U.S. and Canada ship with country-specific keyboard layouts.)

- 
- System Power Status LEDs — informs users of the system's current power status.

### ***System power status LEDs***

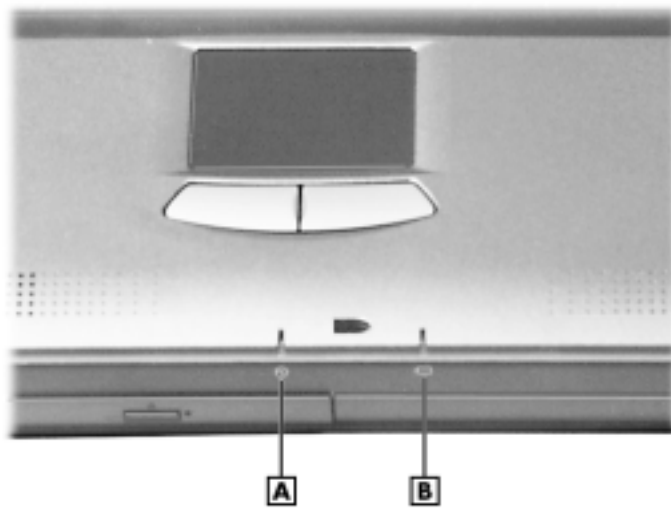

**A** – Power Status LED      **B** – Battery Charging LED

- Power Status LED — lights green when system is using AC power. When the system is using battery power, this LED lights to indicate the following:

Lights green when the system power is on.

Blinks green when the system is in Suspend mode.

Lights yellow (blinks when in Suspend mode) to indicate that battery power is at 8% capacity or less.

Lights amber (blinks when in Suspend mode) to indicate that battery power is at 3% capacity.

---

 **Note:** When both the primary and a secondary battery are installed, the power status LED indicates the total (primary plus secondary) battery status.

---

- Battery Charging LED — lights to indicate battery charging activity.

Lights amber when the primary battery is charging. Blinks amber to indicate an error. The primary battery is installed in the battery bay.

Lights green when the secondary battery is charging. Blinks green to indicate an error. The secondary (optional) battery is installed in the VersaBay III.



- 
- NEC VersaBay III™ — A 24X CD-ROM drive, a SuperDisk drive, or a DVD-ROM drive comes installed in the NEC VersaBay III on the front of the system.

The VersaBay III accepts additional options, including an optional SuperDisk drive, second Li-Ion battery, or an additional hard disk drive.

## ***Around the Back of the System***

You will find system ports for connecting optional devices (like a printer, a docking station, or an external monitor) on the back of the NEC Versa. These ports are described after the figure.

***Ports on the back of the system***

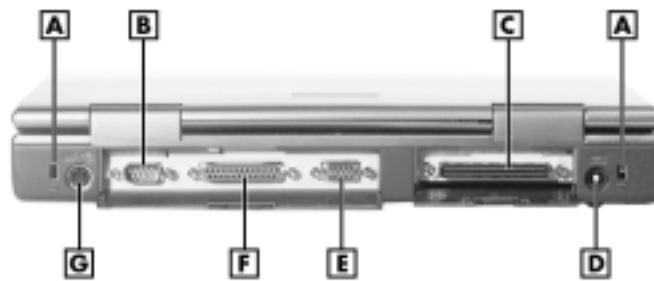

- |                          |                                  |                           |
|--------------------------|----------------------------------|---------------------------|
| <b>A</b> – PortBar Notch | <b>B</b> – Serial Port           | <b>C</b> – Expansion Port |
| <b>D</b> – AC Power Port | <b>E</b> – External Monitor Port | <b>F</b> – Parallel Port  |
| <b>G</b> – PS/2 Port     |                                  |                           |

- PortBar Notches — Use these notches to secure the PortBar to the back of the system.
- Serial Port — Use this port to connect an external modem or other serial device.
- Expansion Port — This port (also called the Docking port) provides a connection for NEC Versa LX options including the NEC Versa Dock and the NEC Versa PortBar.

---

### **CAUTION**

Only dock the NEC Versa LX system on the NEC Versa Dock. The cover of the NEC Versa Dock is specially designed to allow for proper system cooling.

---

- AC Power Port — Use the power jack to attach the NEC Versa to a DC power source, such as the AC adapter or the optional auto adapter.
- External Monitor (Video) Port — Use this 15-pin port to attach an external monitor to the NEC Versa. The user can run the LCD display and the external monitor simultaneously or run either alone.

- **Parallel Port** — Use this port to connect a parallel printer or other parallel device. The port is an Enhanced Capabilities Port (ECP). The ECP standard provides a greater processing speed than the conventional parallel port. It also supports Enhanced Parallel Port (EPP), bi-directional, and uni-directional protocols.
- **PS/2 Port** — Use the standard PS/2 port to connect an external PS/2-style mouse or a PS/2-style keyboard to the system. With an optional Y-cable adapter, the user can connect both a mouse and a keyboard at the same time.

## ***Around the Left Side of the System***

The left side of the NEC Versa offers the following features, which are described after the figure.

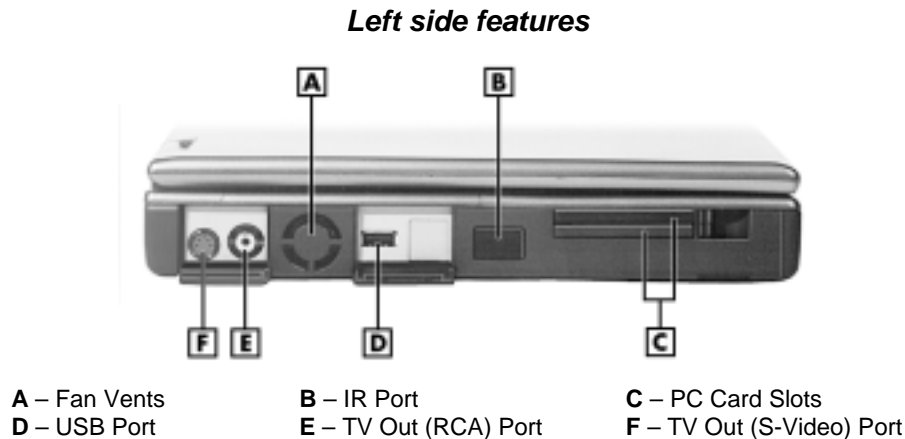

- **Fan Vents** — Allows the system to cool properly and maintain a safe operating temperature.

### **CAUTION**

Always keep the fan vents clear to allow proper system cooling.

- **IR Port** — Transfers files between the NEC Versa and an IR-equipped desktop, notebook computer, or other devices.

 **Note:** The NEC Versa LX ships with the IR port disabled.

- **PC card slots** — Provides two slots for inserting two Type II PC cards or one Type III PC card.

- 
- **USB Port** — Connects up to 127 USB-equipped peripheral devices (printers, monitors, scanners, etc.) to the NEC Versa.
  - **TV Out (S-Video) Port** — Uses a television set equipped with an S-Video input jack as an external monitor. This port supports both NTSC and PAL signals.
  - **TV Out (RCA) Port** — Uses a television set equipped with a standard RCA jack as an external monitor. This port supports both NTSC and PAL signals.

---

 **Note:** The TV Out ports do not support the SECAM signal used in some countries.

---

---

## Around the Right Side of the System

The right-side of the NEC Versa offers the features shown in the following figure. Features are described after the figure.

### Right side features

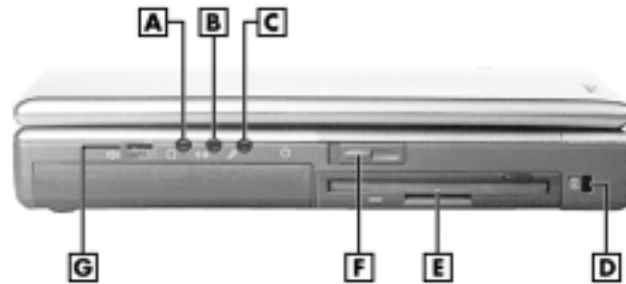

- A** – Headphones/Line Out    **B** – Line In    **C** – External Microphone  
**D** – Kensington Lock    **E** – File Bay    **F** – Power/Sleep Button  
**G** – Audio Volume

#### ■ Audio ports

- Headphones/Line-Out — Allows the user to connect external headphones or speakers to the NEC Versa. Plugging in headphones disables the built-in system speakers.
- Line-In — Uses another audio system, like a home stereo, as an input source. Use a cable to connect to the Line-Out port on the other audio system to record or play.
- External Microphone (MIC) — Allows the user to connect an external microphone for monophonic recording or amplification through the unit. Plugging in an external microphone disables the built-in microphone.

- Kensington Lock — Lets the user provide added security by installing an optional Kensington Lock.
- File Bay — The NEC Versa ships with a 3.5-inch, 1.44 MB diskette drive or the SuperDisk drive installed in the file bay.

- 
- **Power/Sleep Button** — slide the Power/Sleep button toward the front of the system to power on, power off, and to put the computer into Suspend mode.

- Slide the Power/Sleep button toward the front of the system to power on.

- Hold the Power/Sleep button in place for 4 or fewer seconds to put the system into Suspend mode. (*Before using the Power/Sleep button to put the system into Suspend mode, set the System Switch BIOS parameter to the Sleep button.*)

- Hold the Power/Sleep button in place for more than 4 seconds to initiate power override (powers off the system).

The Power/Sleep button is a “smart” switch, meaning that it recognizes when the system is in Suspend mode. If in Suspend mode, the user cannot power off until he/she slides forward the Power/Sleep button again to bring it out of Suspend mode.

In addition, the Smart Power switch invokes an orderly shutdown in the Windows 95 and Windows NT environments. If the user uses the Power/Sleep button to turn off the system while applications are running, the Smart Power Switch alerts the operating system. The operating system prompts the user to save all data and invokes an orderly shutdown procedure.

Put the unit in Suspend mode when you need to be away from the system for a short period of time and want to return to where you left off.

Suspend mode shuts down all devices in the system while retaining data and system status. Use the **Fn-Power/Sleep** key combination to initiate a manual save-to-file. Slide the Smart Power switch (Power/Sleep button) toward the front of the system to resume from a save-to-file.

- **Volume Control** — Allows the user to control the speaker volume.

---

## Around the Bottom of the System

The bottom of the NEC Versa offers the features shown next. Features are described after the figure.

**Bottom features**

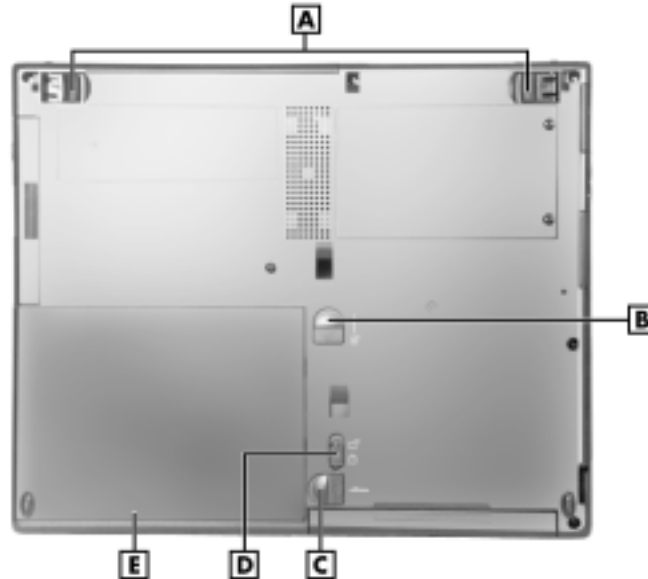

- |                                   |                                      |
|-----------------------------------|--------------------------------------|
| <b>A</b> – Height Adjustment Feet | <b>B</b> – Battery Bay Release Latch |
| <b>C</b> – VersaBay Release Latch | <b>D</b> – VersaBay Release Lock     |
| <b>E</b> – Battery Bay            |                                      |

- Height Adjustment Feet — Allows the user to modify the angle of the NEC Versa for easier viewing and typing.
- Battery Bay Release Latch — Allows the user to release and remove the system's main battery.
- NEC VersaBay III Release Lock and Latch — Allows the user to remove the device currently installed in the bay.
- Battery Bay — Contains the system's main battery. It is a twelve-cell Lithium-Ion (Li-Ion) battery.

## Internal Components

Review the following sections for a description of the system's internal hardware.

### Battery Pack

The system uses a rechargeable Lithium-Ion (Li-Ion) battery as its transient power source. The battery pack installs in the compartment next to the VersaBay III on the bottom of the NEC Versa.

---

## **Hard Disk Drive**

A standard 2.5-inch, 9.5 mm or 12.7 mm hard disk drive ships with the system. Some of the earlier non-AGP 200-MHz, 233-MHz, and 266-MHz systems have a non-user replaceable hard disk drive.

## **File Bay**

The NEC Versa LX ships with a 3.5-inch, 1.44 MB diskette drive or the SuperDisk drive installed in the file bay.

## **VersaBay III**

A 24X CD-ROM drive or a DVD-ROM drive comes installed in the NEC VersaBay III on the front of the system.

## **CPU Board**

The CPU board is a rectangular-shaped board located above the main board. The CPU board is part of a subassembly, which includes a heat sink and the CPU board.

## **Audio Board**

The audio board provides the NEC Versa system with its audio I/O capabilities via a line-in jack, headphone and microphone jacks. It is situated on top of the main board.

## **CMOS Battery**

The lithium battery (3 Volts, 30 mAH capacity) is attached to P28 on the main board. It provides short-term battery backup and prevents data loss in the system's complementary metal-oxide semiconductor (CMOS) RAM. This memory area contains information on the system's configuration like date, time, drives, and memory. The CMOS battery has a useful life of approximately three years.

## **Bridge Battery**

The bridge battery saves the memory contents and system status for up to 5 minutes while changing the main battery. It is connected to the main board via connector P5. The AC adapter maintains voltage in the bridge battery when the system is powered on or off. The bridge battery stores 7.2 Volts, 70 mAH.

---

# ChipSet

The following table provides information on the system chipset.

## System Chipset

Chip	Manufacturer	Description	Technology
Intel Tillamook MMO 200/233 or Intel Mobile Pentium II MMO 233/266/300/333/366/400	Intel	200/233/266/300/333/366/ 400 MHz CPU	320-pin TCP
82430TX (supporting Tillamook) 82443BX (supporting Pentium) PIIX4E (all models)	Intel	System Controller	
PC97338VJG	National Semiconductor	Super I/O	100-pin TQFP
ATI 3D Rage LT Pro or ATI 3D Rage LT Pro AGP	ATI	Video	
ESS Maestro2E	ESS Technology	PCI Audio	
ES1918 (non-AGP models) ES1920 (AGP models)	ESS Technology	AC97 Link	
M38813E4 (non-AGP models) M38813M4 (AGP models)	Mitsubishi	Keyboard Controller	
RB5C478	Ricoh	PCI CardBus Controller	

---



# 2

## System Configuration and Setup

- Power Sources for Your NEC Versa
- BIOS Setup
- NEC CSD Utilities
- Software Applications and Drivers

---

## ***Power Sources for Your NEC Versa***

The NEC Versa can be powered using three different sources, making it a truly portable system. Operate your NEC Versa just about anywhere using one of the following power sources:

- the AC adapter connected to an electrical wall outlet (using AC power).
- the battery pack or an optional second battery pack.
- the optional Auto adapter.

Read the following sections for specific steps on powering on the system with these power sources.

### ***Using the AC Adapter***

Use the AC adapter and power cable that came with your NEC Versa to run your computer on alternating current (AC) power, or to recharge the battery pack. Use the AC adapter whenever a wall outlet is nearby.

Keep the adapter connected whenever possible. The AC adapter charges the battery whether or not you are using the NEC Versa or have the system powered on.

---

#### **WARNING**

Do not attempt to disassemble the AC adapter. The AC adapter has no user-replaceable or serviceable parts inside. Dangerous voltage in the AC adapter can cause serious personal injury or death. The AC adapter is intended for use with a computer. Both must meet EN609050 standards.

---

---

## AC Adapter



A – AC Adapter    B – AC Power Cable

---

 **Note:** Check that the AC outlet voltage falls in the range of 100-240 Volts AC. Verify that the cord and plug are appropriate for your AC source.

---

Connect the AC adapter as follows:

1. Connect the AC adapter cable to the power port on the back of your NEC Versa.
2. Plug one end of the AC power cable into the AC adapter and the other end into a properly grounded 120- or 240-volt wall outlet.

---

 **Note:** The AC power cable type that your system uses depends on the country where you are using it. Contact the local dealer to purchase the correct power cable.

---

## Connecting the AC Adapter

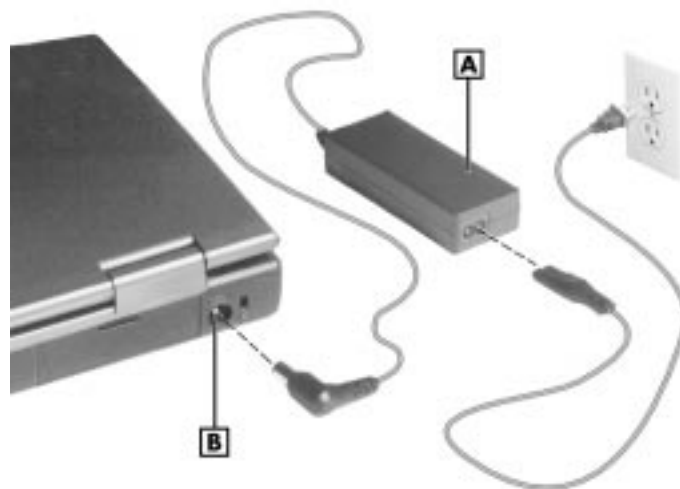

A – AC Adapter    B – Power Port

---

 **CAUTION**

Do not cover or place objects on the AC adapter. Keeping the adapter clear of objects lets the adapter cool properly during use.

---

### *Powering On*

Power on the system as follows:

1. Locate the latch on the front of the LCD panel, slide it to the right, and raise the panel.
2. Locate the Power/Sleep button and slide it toward the front of the system to turn on system power.

### ***Using the Main Battery Pack***

The NEC Versa comes with a rechargeable Lithium-Ion (Li-Ion) battery pack. You can run your system on battery power for approximately two to four hours with power management features enabled. It's easy to install and remove.

Your NEC Versa system provides tools to help you keep track of the main (or an optional) battery's power level. These include the power status LED described in Chapter 1, and SystemSoft's PowerProfiler™ (for Window NT systems, only) described later in this chapter. Both provide important battery status information.

When battery power is very low, the power LED flashes amber.

When battery power gets low, do one of the following:

- Slide the Power/Sleep button toward the front of the system and hold it in place for 4 or fewer seconds to put your system in Suspend mode. (*Before using the Power/Sleep button to put the system into Suspend mode set the System Switch BIOS parameter to Sleep button.*) Remove the battery pack and replace it with a fully charged battery.
- Suspend in Windows 95 from the Start menu.
- Leave the battery pack in the system and connect your NEC Versa to the AC adapter and a wall outlet. If you connect the system to AC power and keep the system within standard operating temperatures, the battery recharges in approximately 2–3 hours whether or not you use your system.

You can also buy an optional NEC Versa battery charger to charge your battery. See the NEC CSD web site at <http://www.nec-computers.com/>.

---

## **⚠ WARNING**

To prevent accidental battery ignition or explosion, adhere to the following:

- Keep the battery away from extreme heat.
  - Keep metal objects away from the battery terminals to prevent a short circuit.
  - Make sure the battery is properly installed in the battery bay.
  - Read the precautions printed on the battery later in this chapter.
- 

### *Determining Battery Status*

You can determine battery status via the battery gauge LEDs on the front of the Lithium-Ion battery that ships with your NEC Versa LX computer.

#### ***Lithium-Ion battery***



**A** – Battery Gauge LED    **B** – Alignment Groove    **C** - LED Status Button

To check battery status, press the Battery Gauge LED status button to illuminate the LEDs. The battery gauge LEDs indicate the following:

---

## Battery gauge LEDs

Battery Power Status	LED Indicator
100% to 75%	■ ■ ■ ■ ■
75% to 50%	■ ■ ■ ■
50% to 25%	■ ■
25% to 10%	■
10% to 1%	※ (blinks)

---

 **Note:** If the battery gauge LEDs display a combination other than those depicted in the illustration, recharge the battery overnight. If the problem still persists, contact NEC CSD Technical Support.

---

In Windows NT environments, in addition to the battery gauge LEDs, use SystemSoft's PowerProfiler™ to determine battery status. Click on the battery icon located on the taskbar. The PowerProfiler battery page displays.

To return the battery to its normal state, try the following:

- remove and then reinstall the battery
- fully recharge the battery.

### *When to Change the Battery*

The following symptoms indicate that battery life is nearing an end. Replace batteries that display these symptoms.

- Shorter work times.
- Discoloration, warping.
- Hot to the touch.
- Strange odor.

---

## Battery Handling

Keep the following in mind when removing or replacing a battery.

- Use only the battery designed for your system in the NEC Versa. Mixing other manufacturer's batteries, or using a combination of very old and new batteries can deteriorate battery and equipment performance.
- Turn off power to the system after use. Keeping system power on can degrade battery performance and shorten battery life.
- Clean the battery terminals with a dry cloth when they get dirty.
- Keep the battery out of the reach of children.

## Replacing the Battery

Replace the battery pack installed in your NEC Versa system as follows.

---

 **Note:** Use the batteries in the NEC Versa computer for which they are designed. Also, installing another manufacturer's battery, or using a combination of very old and new batteries can deteriorate battery and equipment performance.

---

1. Save your files, exit Windows, and put your system into Suspend mode or turn off system power.
2. Close the LCD and turn the system over.
3. Slide the battery release latch toward the back of the system and hold firmly.

### **Battery Bay Release Latch**

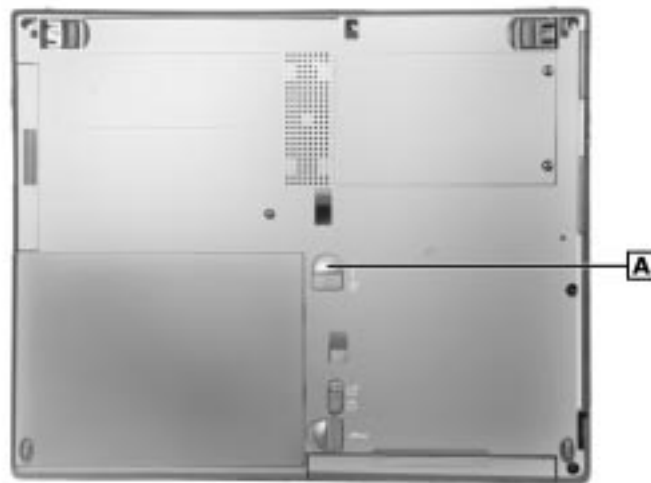

A – Battery Bay Release Latch

- 
4. Continue to hold the battery release latch as you slide the battery out of the system.

#### ***Removing the battery***



5. Insert the new battery as follows:
  - Locate the alignment groove on the edge of the battery.
  - Locate the alignment groove inside the battery bay.
  - Align the grooves on the battery with the grooves in the battery bay.
  - Slide the battery into the battery bay until securely locked into place.

#### ***Inserting the battery pack***



6. Turn the system over.



---

## Battery Precautions

To prevent accidental battery ignition, rupture, or explosion, adhere to the following precautions.

---

### **WARNING**

There is a danger of explosion if the battery is incorrectly replaced. Replace only with the same or equivalent type recommended by the manufacturer. Discard used batteries according to the manufacturer's instructions.

To avoid personal injury and property damage, read these battery precautions on handling, charging, and disposing Li-Ion batteries.

- Keep the battery away from heat sources including direct sunlight, open fires, microwave ovens, and high-voltage containers. Temperatures over 140° F (60°C) may cause damage.
- Do not drop or impact the battery.
- Do not disassemble the battery.
- Do not solder the battery.
- Do not puncture the battery.
- Do not use a battery that appears damaged or deformed, has any rust on its casing, is discolored, overheats, or emits a foul odor.
- Keep the battery dry and away from water.
- Keep metal objects away from battery terminals. Metal objects in contact with the terminals can cause a short circuit and damage.
- If the battery leaks:
  - If the battery leaks onto skin or clothing, wash the area immediately with clean water. Battery fluid can cause a skin rash and damage fabric.
  - If battery fluid gets into eyes, DO NOT rub; rinse with clear water immediately for at least 15 minutes and consult a doctor.

Take extra precautions to keep a leaking battery away from fire. There is a danger of ignition or explosion.

---

---

## *Recharging Battery Precautions*

Adhere to the following precautions when recharging the primary or secondary battery.

- Use only the NEC battery charger designed for your NEC Versa battery type. Different NEC Versa models require different batteries and battery chargers.
- Charge the battery for the specified charge time only.
- During charging, keep the environmental temperature between 32°F and 104°F (5°C to 35°C).
- Read the instructions that came with the battery charger before charging the battery.

## *Extending Battery Life*

While on the road, it is important to be aware of the simple things you can do to extend the life of the system's main battery. One way is to keep the brightness setting on the panel low. Use the slide switch on the front of the panel (12.1-inch TFT, SVGA panel only) or use the **Fn+F8** and **Fn+F9** function keys to control the brightness.

## **NEC VersaBay III Battery**

The NEC VersaBay III battery provides an optional second Lithium-Ion (Li-Ion) battery to use in your NEC Versa LX computer. Inserting a second fully charged battery increases battery life to approximately 4 to 5 hours.

See the NEC CSD web site at <http://www.nec-computers.com/> for details about the NEC VersaBay III battery.

## **Internal Batteries**

The twelve-cell Lithium-Ion (Li-Ion) battery provides the main power source in your NEC Versa LX computer. See Chapter 9 for a list of battery specifications. In addition to this battery, the CMOS battery and bridge battery also provide system power.

## *CMOS Battery*

This lithium battery provides battery backup and prevents data loss in the system's complementary metal-oxide semiconductor (CMOS) RAM. This memory area contains information on the system's configuration, for example date, time, drives, and memory. The CMOS battery may discharge completely if the NEC Versa notebook remains unused for approximately two months.

---

## Bridge Battery

The bridge battery saves your system status in Suspend mode for up to five minutes. This gives you time to install a fully charged battery or plug in AC power when your battery charge becomes low.

Only an authorized NEC CSD technician can change a bridge battery.



### CAUTION

Connect your NEC Versa system to AC power for a full 24 hours before using it on battery power for the first time. Doing so insures that the bridge battery is fully charged and that no data is lost during a battery change.

---

## BIOS Setup

Your NEC Versa LX computer comes with a hardware program called BIOS Setup that allows you to view and set system parameters. BIOS setup also allows you to set password features that protect your system from unauthorized use.

Use BIOS setup to:

- set the current time and date
- customize your operating system to reflect your computer hardware
- secure your system with a password
- balance your performance needs with power conservation.

## How to Enter the BIOS Setup

Access the BIOS utility at power-on. Just press **F2** when a prompt similar to the following appears.

Press <F2> to enter Setup.

When you press **F2** to enter BIOS Setup, the system interrupts the Power-On Self-Test (POST) and displays the current CMOS RAM settings.



**Note:** To pause the POST, press and hold down **INS**. To view POST messages, press and hold down **ESC** when prompted.

---

If the system detects an error during POST, it prompts you with a double beep and a message: "Press <F1> to resume." If you press **F1**, the system enters BIOS Setup automatically. If you want to fix the error, carefully read the error message that appears above the prompt (taking notes if you want), and press **F2**.

---

## BIOS Setup Utility Main Menu

After you press **F2**, the system displays the BIOS Setup Main Menu screen, similar to the following.

### BIOS Setup Main Menu

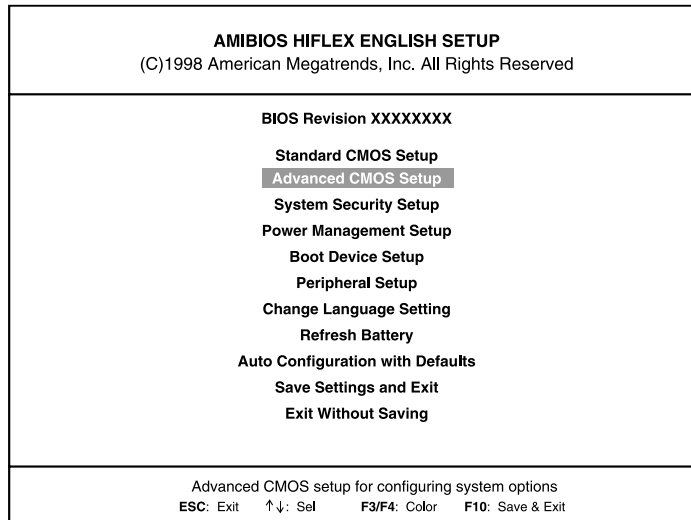

Use the up and down arrow keys (located on the lower right corner of the keyboard) to toggle through the BIOS Setup menu items.

## How to Use BIOS Setup

The following sections describe how to use BIOS Setup, including these topics:

- Looking at screens
- Using keys
- Checking and setting system parameters

---

## Looking at Screens

BIOS setup screens have three areas as shown next.

### **Advanced CMOS Setup Menu**

<b>AMBIOS SETUP – ADVANCED CMOS SETUP</b> (C)1998 American Megatrends, Inc. All Rights Reserved		
Video Out Type	NTSC	<b>Item-specific help text appears here.</b>
LCD Panel View Expansion	ON	
PS/2 Port Hot Swap	Enabled	
Internal Mouse	Enabled	
Graphics Aperture Size	256MB	
		ESC Exit    ↑↓    Select PgUp/PgDn: Modify F3/F4: Color

- **Parameters** — The left part of the screen. This area lists parameters and their current settings.
- **Available Options and Help** — The right part of the screen. This area lists alternate settings and Help text for each parameter.
- **Key Legend** — The bottom right corner of the screen. These lines display the keys that move the cursor and select parameters.

Options that are grayed out are not available for the current selection.

## Using Keys

The following table lists the BIOS Setup keys and their functions.

### **BIOS Setup Key Functions**

<b>Key</b>	<b>Function</b>
↑ ↓	Moves the cursor between the displayed parameters.
PgUp/PgDn	Toggles through the current parameter settings.
Tab	For some parameter settings, moves the cursor between the subfields. Also moves the cursor to the next line or selection. For example, for System Time, Tab moves the cursor from hour to minute to second.
ESC	Exits the current screen and returns to the Main Menu screen. From the Main Menu screen, displays the prompt, "Quit without saving."
F3/F4	Changes the screen color.
F10	Saves and exits the BIOS Setup utility.

---

## Checking/Setting System Parameters

See the following table for a list of parameters, their factory default settings, and alternate settings. A description of each setting follows the table.

To reset all parameters to the default settings, select Auto Configuration with Defaults from the BIOS Setup Main Menu and highlight Yes and press **Enter**.

### **BIOS Setup Parameters**

<b>Parameter</b>	<b>Default Setting</b>	<b>Alternate Setting(s)</b>
<b>Standard CMOS Setup</b>		
Date	mm/dd/yyyy	
System Memory		(automatically detected)
System Time	hh/mm/ss	
Diskette Drive A	1.44 MB, 3.5 inch	Not installed/1.44 MB
Diskette Drive B <sup>1,8</sup>	Not installed	1.2 MB, 5.25; 1.44 MB, 3.5 inch
Internal	Auto	User Defined, CDROM SuperDsk, Not installed
32-Bit Mode	On	Off
VersaBay	Auto CDROM	User Defined, CDROM SuperDsk, Not installed
32-Bit Mode	On	Off
Docking Station IDE <sup>1</sup>	Auto	User Defined, CDROM SuperDsk, Not Installed
DS Internal <sup>1</sup>	Auto	User Defined, CDROM SuperDsk, Not Installed
DS VersaBay <sup>1</sup>	Auto	User Defined, CDROM SuperDsk, Not Installed
Boot Sector Virus Protection <sup>8</sup>	Disabled	Enabled
<b>Advanced CMOS Setup</b>		
Video Out Type	NTSC	PAL
LCD Panel View Expansion	On	Off
PS/2 Port Warm Swap	Enabled	Disabled
Internal Mouse	Enabled	Disabled
Graphics Aperture Size <sup>8</sup>	256 MB	4 MB, 8 MB, 16 MB, 32 MB, 64 MB, 128 MB
<b>System Security Setup</b>		
Change Supervisor Password	Press Enter	
Change User Password <sup>2</sup>	Press Enter	
Boot Password Required <sup>3</sup>	No	Yes
Resume Password Required <sup>3</sup>	No	Yes

## **BIOS Setup Parameters**

<b>Parameter</b>	<b>Default Setting</b>	<b>Alternate Setting(s)</b>
<b>Power Management Setup</b>		
System Switch	Power Button	Sleep Button
Power Management under AC	Off	On
Power Savings Level	Longest Life	High Perform/Custom/Off
CPU Speed Control <sup>48</sup>	100%	12.5%, 25%, 50%
Hard Disk Timeout <sup>4</sup>	2 minutes	5/30/45 sec; 1/4/6/8/10/15 min
Video Timeout <sup>4</sup>	2 minutes	Off 30/45 sec.; 1/4/6/8/10/15 min. Off
Peripheral Timeout	On	Off
Audio Device Timeout <sup>4</sup>	On	Off
Standby Timeout <sup>4</sup>	4 minutes	Off/1/2/6/8/10/15 min.
Auto Suspend Timeout <sup>4</sup>	10 minutes	Off/5/15/20/25/30 min.
LCD Suspend	Disabled	Enabled
Suspend Option	Suspend	STF
Auto Save to File	Enabled	Disabled
Panel Brightness	Auto	User Defined
Suspend Warning Tone	Enabled	Disabled
Remote Power On <sup>8</sup>	Enabled	Disabled
Resume Signal <sup>8</sup>	PME#	RI
Modem Ring Resume	On	Off
Wake Up Alarm	Disabled	Enabled
Resume Alarm Time <sup>5</sup>	Off	Set time in 5 min. increments when Wake Up Alarm is set.
<b>Boot Device Setup</b>		
Quick Boot	Enabled	Disabled
Silent Boot <sup>8</sup>	Enabled	Disabled, Black
Boot from Docking Station IDE <sup>1</sup>	No	Yes
Boot Display Device	Simul. Mode	CRT Only, LCD Only
Docking Station Video <sup>1</sup>	Dock Stn.	Portable
BootUp NumLock	Auto	On, Off
1st Boot Device <sup>6</sup>	SuperDsk	Disabled/1 <sup>st</sup> Fnd IDE/Floppy /SuperDsk/CDROM/SCSI/ Network
2nd Boot Device <sup>6</sup>	CDROM	Disabled/1 <sup>st</sup> Fnd IDE/Floppy /SuperDsk
3rd Boot Device <sup>6</sup>	Floppy	Disabled/1 <sup>st</sup> Fnd IDE/SuperDsk /CDROM

## **BIOS Setup Parameters**

<b>Parameter</b>	<b>Default Setting</b>	<b>Alternate Setting(s)</b>
4th Boot Device <sup>6</sup>	1 <sup>st</sup> Fnd IDE	Disabled/Floppy/SuperDisk /CDROM
Try Other Boot Devices	Yes	No
1 <sup>st</sup> IDE Hard Drive	Internal	VersaBay/DS Internal DS VersaBay
2 <sup>nd</sup> IDE Hard Drive	VersaBay	Internal/DS Internal DS VersaBay
3 <sup>rd</sup> IDE Hard Drive	DS Internal	Internal/VersaBay DS VersaBay
4 <sup>th</sup> IDE Hard Drive	DS VersaBay	Internal/VersaBay/DS Internal
<b>Peripheral Setup</b>		
Internal Hard Drive	Enable	Disable
USB Controller	Disabled	Enabled
Serial Port	Auto	Disabled/(PnP OS Setup <sup>7</sup> ) COM1,IRQ4/COM2,IRQ3 COM3,IRQ4/COM4,IRQ3
Parallel Port	Auto	Disabled/LPT1/LPT2 (PnP OS Setup <sup>7</sup> )
Parallel Mode	ECP	Uni-Dir/Bi-Dir EPP
IR Serial Port	Disabled	Auto/(PnP OS Setup <sup>7</sup> ) COM2,IRQ3/COM3,IRQ4 COM4,IRQ3

### **Notes**

- <sup>1</sup> These setup items are only visible when system is docked.
- <sup>2</sup> Supervisor password has to be previously set up.
- <sup>3</sup> Only active after a password is set up.
- <sup>4</sup> Available when power savings is set to custom.
- <sup>5</sup> Resume alarm time is selectable when wake up from suspend alarm is set.
- <sup>6</sup> Bootable device when set to IDE Hard Drive. Only one IDE device is allowed to be bootable.
- <sup>7</sup> Appears only when configured by the Windows 95 device manager.
- <sup>8</sup> Appears only on AGP systems.

## **BIOS Setup Menus**

Read the following descriptions for explanations of items that appear in the BIOS Setup menus, as listed in the preceding table. See the item-specific help that appears on each Setup screen for more details.

### **Standard CMOS Setup**

When you select the Standard CMOS Setup screen you see System Time and System Date parameters as well as drive parameters.

- **Date** — Set your NEC Versa's calendar month, day and year. The calendar clock is year 2000-compliant. These settings remain in memory even after you turn off system power.



---

To set the date, use the **Tab** or arrow keys to move from field to field. Use the **PgUp** or **PgDn** key to change the numbers within each field.

- **System Memory** — Displays the amount of system memory currently installed in your system.
- **Time** — Set the time, enter the current hour, minute, and second in *hr/min/sec*, 24-hour format.

To set the time use the **Tab** or arrow keys to move from field to field. Use the **PgUp** or **PgDn** key to change the numbers within each field.

- **Diskette Drives** — Lets you designate the drive type for your diskette drives.
- **Internal Drives** — Allows you to assign devices to the internal drive(s), file bay and VersaBay, in your system.
- **Docking Station Drives** — Enables and disables the drives installed in a docking station. (These options are only available when the NEC Versa is docked.)
- **Boot Sector Virus Protection** — Write protects the boot sector of the hard disk drive to avoid infection by some virus types.

### *Advanced CMOS Setup*

Advanced CMOS settings let you define the following functions.

- **Video Out Type** — Specifies the signal type used by the video device connected to the TV Out Port.
- **LCD Panel View Expansion** — Specifies whether the panel view is reduced/off or expanded/on.
- **PS/2 Port Warm Swap** — Specifies whether or not you can swap a PS/2 device during system operation.
- **Internal Mouse** — Specifies whether or not you can use both the internal and the external mouse.
- **Graphics Aperture Size** — Sets the graphics aperture size used by the AGP video device.

### *System Security Setup*

- **Change Supervisor Password** — Allows you to establish password protection for entering the BIOS setup utility, booting the system, and resuming from Suspend mode.
- **Change User Password** — Allows you to establish a user password once a Supervisor password is set.
- **Boot Password Required** — Indicates whether or not a password is required during system boot.

- 
- **Resume Password required** — Indicates whether or not a password is required during system resume. Boot Password must be defined to activate this parameter.

### *Power Management Setup*

Your NEC Versa Windows 98 system uses the Advanced Configuration and Power Interface (ACPI) which enables the operating system to manage the power given to each attached device and to turn off a device when not in use. In addition, ACPI enables manufacturers to develop computers that automatically power up with a touch to the keyboard.

The Power Management Setup menu lets you balance high performance and energy conservation using parameters including the following.

- **System Switch** — Lets you use the Power/Sleep button as a Power switch or a sleep button.
- **Power Management Under AC** — Specifies whether to enable power management features when AC power is in use. When AC power is connected to your NEC Versa system, power management is usually disabled. If you enable this parameter, the system automatically activates the power management profile you set, even when AC power is used.
- **Power Savings Level** — Lets you choose one of four levels of power management.
  - **High Performance** provides the greatest system performance with only minimal power conservation.
  - **Longest Life** provides the maximum amount of power savings.
  - **Off** disables power management and all device timeouts.
  - **Custom** lets you define your own power management configuration by selecting values for specific device timeouts. Custom lets you set the following timeouts.
    - **CPU Speed Control** — Allows you to set CPU performance at one of four levels.
    - **Hard Disk Timeout** — Allows you to select the amount of time before your hard disk powers down.
    - **Video Timeout** — Allows you to select the amount of time before your video powers off.
    - **Peripheral Timeout** — Lets you choose on/off for peripheral power management.
    - **Audio Device Timeout** — Allows you to select the amount of time before your audio device powers off.

- 
- Standby Timeout — Allows you to select the system standby timeout period.
  - Auto Suspend Timeout — Defines how much time elapses from the time the system enters Standby mode to the time the system automatically enters Suspend Mode.
  - LCD Suspend/Resume — Allows you to suspend/resume when the LCD panel is opened and closed.
  - Suspend Option — Allows you to specify either Suspend or Save to File (STF) as the default power management mode. In Suspend, after a specified amount of inactivity, your NEC Versa shuts down all devices as you specified in Power Management Setup or applies default timeouts. All your data is automatically recovered from where you left off when you Resume.
  - Automatic STF — After 30 minutes in Suspend mode, the current file is automatically saved to a special file on the hard disk and the system shuts down. To resume, you must press the power button. The system reads the saved file and sets up your system accordingly.

The save-to-file area is present on your hard drive, pressing the **Fn-Power/Sleep** key combination puts the system into Save to File mode. *(Before using the Power/Sleep button to put the system into Suspend mode set the System Switch BIOS parameter to Sleep button.)* For details about creating the save-to-file area, see the section later in this chapter, “HDPREPEZ Utility.”

- Panel Brightness — Lets you select the LCD screen brightness.
- Suspend Warning Tone — Specifies whether the system warning tone sounds when Suspend mode starts. It is best to keep this option enabled.
- Remote Power On — Lets you choose whether the system resumes automatically when an external serial modem receives a ring signal.
- Resume Signal — Lets you select the signal that generates a modem ring resume.
- Modem Ring Resume — Lets you choose whether the system resumes automatically when an internal serial modem receives a ring signal.
- Wake Up from Suspend Alarm/Resume Alarm Time — Lets you set a resume time from Suspend mode.

### *Boot Device Setup*

Boot Device Setup allows you to define the following functions.

- Quick Boot — Specifies whether or not the system performs all tests during system boot.

- 
- Silent Boot — Specifies whether or not to display the NEC logo during system boot.
  - Boot from Docking Station IDE — Specifies whether or not the system boots from the docking station IDE device. (Only when the NEC Versa is docked.)
  - Boot Display Device — Specifies the display device(s) to show the system boot messages on.
  - Docking Station Video — Selects whether or not a video card installed in the Docking Station is enabled at system boot.
  - BootUp NumLock — Specifies whether NumLock is On or Off at system startup.
  - Boot Devices — Specifies the sequence of boot devices and whether or not the system attempts to boot from a device other than those specified.
  - Other Boot Devices — Allows you to specify IDE devices as bootable devices.

### *Peripheral Setup*

The Peripheral Setup menu displays the connection locations between the system and the Input/Output (I/O) ports. This menu also lets you specify different port assignments as needed.

---

 **Note:** If you disable a device in Peripheral Setup, you cannot enable or assign it using the Windows 95 device manager. The device is not listed in the Windows 95 device list. To control the device using the Windows 95 device manager, select any setting other than Disable in Peripheral Setup.

---

- Internal Hard Drive — Allows you to enable or disable the internal hard drive.
- USB Controller — Allows you to enable or disable the USB controller.
- Serial Port — Allows you to disable the port or change its address assignment.
- Parallel Port/Parallel Mode — Lets you disable or reassign the parallel port and select a parallel port mode.
- IR Serial Port — Allows you to enable, disable or reassign the IR serial port.

---

## Other BIOS Setup Options

BIOS Setup offers other options, including the following:

- **Change Language Setting** — Controls the BIOS setup language display. English and Japanese are the available options on AGP models.
- **Refresh Battery** — Allows you to launch the Battery Refresh utility on AGP models. Once launched, the utility fully discharges your battery to eliminate any residual memory effect. Once refreshed, your battery is conditioned to recharge to its full capacity. This process may take up to two hours to complete.
- **Auto Configuration with Defaults** — Loads default settings.
- **Save Settings and Exit** — Accepts changes made to current settings, saves to CMOS, and exits BIOS Setup.
- **Exit Without Saving** — Reverts to previously selected settings and exits Setup.

## Password Protection

Your NEC Versa supports a password for system security on several levels. Once you set a supervisor password, you must enter it before you can enter BIOS Setup, access the system at startup, or resume from Suspend, depending on your configuration selection.

Your system is not protected until you set a user password and you are not prompted to enter a user password until you set a supervisor password.

---

 **Note:** You must set the supervisor password before the BIOS Setup utility allows you to set a user password.

---

## Using BIOS Setup to Set Power Management

Power Management Setup allows you to use the factory-defined power savings level (Longest Life), or choose between High Performance, Custom, or Off. Each provides a special value to your current work effort. These power management levels were designed with you in mind. For example, you can use them under the following circumstances:

- **Longest Life** — Provides the best battery life and good performance. Use while traveling long distances.
- **High Performance** — Provides the best performance and good battery life. Use while on the road or traveling short distances.
- **Custom** — Lets you decide! Set power management levels according to your own needs and present environment.
- **Off** — Works well in an office environment while powering your NEC Versa with AC power.

---

## Using the Save to File (STF) Feature

STF protects the integrity of your working files. For example, if you are called away from your NEC Versa and Suspend mode is selected with auto Save to File active, your system automatically goes into Suspend mode. After 30 minutes, if you don't return, your working environment is saved to a special file on your hard disk.

Using STF can benefit you in the following ways.

- When in STF, there is minimum battery drain.
- Preserves the life of your NEC Versa.
- Saves you time. When you return from that urgent call or meeting, you don't have to reboot, just press the Power/Sleep button to resume system operation.

To configure your NEC Versa's STF feature follow these steps:

1. Access the BIOS setup utility.
2. Select Power Management from the Setup Main Menu.
3. Move the cursor down and highlight Suspend Option.
4. Press the **PgUp** key and select STF.
5. Save the settings and exit BIOS Setup.

There are three ways to invoke the NEC Versa's STF feature, one automatic and two manual.

- After 30 minutes of inactivity, your NEC Versa automatically invokes STF.
- You can manually invoke STF by:
  - pressing **Fn Power/Sleep** simultaneously, before you leave your NEC Versa.
  - Selecting Start, Suspend.

---

 **Note:** When the status bar indicates that there is only 3% power remaining in the system, the NEC Versa automatically performs a Save to File.

---

## Updating the BIOS

Use the BIOS Update Diskette to update your NEC Versa system BIOS. Specifically, the BIOS is the code transmitted onto your system's microprocessor, or central processing unit (CPU).

---

 **Note:** You only need to update the BIOS if NEC CSD makes significant improvements or fixes to the current system BIOS. Your authorized NEC CSD dealer or NEC CSD Support Services representative can help you determine this.

---

If you are informed that the default BIOS needs an upgrade, contact the Versa Laptop Fulfillment Hotline at (800) 842-6446, or NEC CSD Support Services at (800) 632-4525, Fax (801) 981-3133 or access the web site, [www.nec-computers.com](http://www.nec-computers.com) to download the most current BIOS update software.

---

 **Note:** If you purchased and are using this computer outside the U.S. or Canada, please contact a local NEC CSD office or dealer in your country.

Reference the booklet, "Getting Service and Support in Asia, Australia, and Europe," to find out how to contact the local office in your country.

---

Only use the BIOS upgrade diskette for your specific model and be sure to prepare the diskette before upgrading the BIOS.

### *Preparing the BIOS Upgrade Diskette*

Before using the BIOS upgrade diskette you must make the diskette BIOS flash ready. Refer to the **readme.txt** file on the diskette before using the diskette.

Follow these instructions to prepare the BIOS Upgrade diskette.

1. Scan your hard drive for any computer viruses.
2. Enable the diskette for write access.
3. Insert the diskette into the file bay drive.
4. Type **a:install** or **b:install** (depending upon the hardware configuration) at the DOS prompt and follow the on-screen instructions.

Install.bat copies the DOS system files from your hard drive onto the BIOS Upgrade diskette to make it BIOS flash ready.

The system prompts you when the process is complete.

5. Scan the BIOS Upgrade diskette for computer viruses.

The diskette is ready for use.

6. Follow the instructions for performing the BIOS update.

---

## Changing the Switch Settings

Before performing the BIOS update, be sure to change the switch settings to enable BIOS flash on AGP models. Set switch 5 to “ON” before performing the BIOS update. For details about setting the switches, see “Switch Settings” in Chapter 3.

## Performing the BIOS Update

Use the following procedure to perform the actual BIOS update.

1. Make sure that the computer is operating under AC power, and that the power is off. Insert the BIOS Update diskette into the file bay drive.
2. Power on the computer with the diskette in the file bay drive. The computer boots and automatically loads the utility. A message similar to the following appears:

The NEC BIOS Update Utility should not be used to modify the BIOS in a Versa system which is docked. If your Versa is docked, please exit the BIOS Update Utility, power down, and undock your Versa before running the utility. Plug in your AC cable before restarting the flash utility.

3. Press **Enter** to continue.

The utility checks the currently installed BIOS version and the diskette’s BIOS version. The Main menu appears.

4. Use the arrow keys to highlight the “Display BIOS Version” option on the Main menu. Use this option to check the currently installed BIOS version and the version of the new replacement BIOS.

Press any key to return to the Main menu.

5. Highlight the “Install New BIOS” option and press **Enter**.
6. Press **Y** and then press **Enter**. After a brief pause, a message appears telling you to remove the diskette in the file bay drive.
7. Remove the diskette and press any key to continue. The utility updates the BIOS.

Power off your computer. The next time you power on your computer, you will have the latest NEC Versa LX computer BIOS revision level.

8. Enter Setup to restore the default parameter settings.
9. Be sure to modify any custom settings that you may have configured.
10. On AGP models, be sure to change switch 5 back to “OFF” after completing the BIOS update. For details about setting the switches, see “Switch Settings” in Chapter 3.



---

## **NEC CSD Utilities**

NEC CSD provides several programs and routines designed to make your NEC Versa run more efficiently.

The NEC CSD utilities include:

- NEC Customize Utility
- HDPREPEZ Utility

### **NEC Customize Utility**

In Windows 95 systems and Windows NT systems, the NEC Customize utility gives you the option to install or launch:

- NEC CSD custom wallpaper — installs wallpaper displaying the NEC logo.
- Application and Driver CD — installs software applications, drivers, online documents, etc.
- NEC VersaBay Swapping Utility (Windows 95 only) — takes advantage of warm swapping your VersaBay devices.
- IR setup utility to enable the IR port (Windows 95 only) — enables the IR port.
- NEC-supplied mouse driver (Windows NT only) — use this option to take advantages of the VersaGlide features.

The NEC Customize Utility screen consists of the following.

- A window at the top half of the screen lists the available options.
- The window below the options list displays a description of each option when the option is highlighted.
- The Launch button initiates a selected option when clicked.
- The More Info button provides an overview of the NEC Customize Utility.
- The Exit button closes the NEC Customize Utility.

### **Using the NEC Customize Utility**

Follow these steps to use the NEC Customize utility.

1. Double click the NEC Customize icon.
2. From the display window, select the desired option.
3. Click Launch to initiate the selected option.

- 
4. Follow the on-screen instructions to process the selected option.  
For some of the selected options you are prompted to reboot your system.
  5. If necessary, click Exit to close the NEC Customize dialog box.

## **HDPREPEZ Utility**

Using the HDPREPEZ utility automatically configures your NEC Versa's system's save-to-file (STF) area on the hard disk drive.

---

 **Note:** For more details about the HDPREPEZ utility, see the HDPREPEZ.TXT file in the C:\NECUTILS\HDPREP directory.

---

### *Using HDPREPEZ in Windows 95 and Windows 98*

In Windows 95 and Windows 98, run the HDPREPEZ utility if you increase the memory capacity in your NEC Versa beyond the factory installed base memory.

Follow these steps to run the HDPREPEZ utility.

1. Power off and restart your NEC Versa.
2. At the statement "Starting Windows 9x," press **F8**.
3. From the Startup menu, select "Safe Mode Command Prompt Only," usually Option 6.
4. Enter MS-DOS. At the c: prompt, type **cd \necutils\hdprep** and press **Enter** to change to the \necutils\hdprep directory.
5. Type **HDPREPEZ** and press **Enter**. The utility automatically prepares your NEC Versa for the newly installed memory.
6. Power off your system and then power on. A file, large enough to accommodate your system's memory is created on the hard disk drive.

### *Using HDPREPEZ in Windows NT*

In Windows NT, run the HDPREPEZ utility if you increase the memory capacity in your NEC Versa beyond the factory installed base memory.

Follow these steps to run the HDPREPEZ utility.

1. Close all background applications before running the HDPREPEZ utility.
2. Go to Start, Programs, AMI Save to File.
3. Select Create STF File.

A DOS box displays and advises you to close all background applications. The message also indicates that your system reboots when the process is complete. Finally, the message prompts you to "Proceed Y/N?"

- 
4. Enter **Y** to create the STF file.

A file, large enough to accommodate your system's memory is created on the hard disk drive. When the process is complete, your system reboots.

## ***Software Applications and Drivers***

A variety of software\* applications and drivers are provided on the Application and Driver CD for the NEC Versa LX that ships with your system. Some of these applications and drivers are already installed as part of your operating system environment. These applications and drivers let you take full advantage of your system resources.

Once you have installed an application from the Application and Driver CD access the program through its desktop icon or through the Start, Programs menu.

The software\* applications available on the Application and Driver CD vary according to your operating system environment and may include:

- PowerQuest® PartitionMagic®
- Intel LANDesk® Client Manager
- SystemSoft® PowerProfiler (Windows NT only)
- SystemSoft® CardWizard (Windows NT only)
- Puma Intellisync 97 or Intellisync for Notebooks
- McAfee VirusScan™
- Microsoft® Internet Explorer
- Netscape Navigator™
- Adobe® Acrobat® Reader

\* The software listed here is current at the time of printing and subject to change without notice.

### ***Using the Application and Driver CD***

Use the Application and Driver CD to install applications, drivers, utilities, Internet browsers, and the online NEC Help Center.

#### ***Launching the Application and Driver CD***

Follow these steps to launch the Application and Driver CD using the NEC Customize icon.

1. Insert the Application and Driver CD into the CD-ROM drive.
2. Double click the NEC Customize icon.
3. Select Launch Application and Driver CD.

- 
4. Click Install to launch the CD.

The Application and Driver CD dialog box appears.

### *Installing the Software*

The Application and Driver CD dialog box consists of the following components.

- Selection Tabs — Located just below the title bar, each tab represents a software category. The selection tabs include Applications, Drivers, Utilities, Internet browsers, and the online NEC Online Documentation.
- Description — Located in the bottom portion of the dialog box, the text describes the selected or highlighted software category or application, driver, etc.
- Install — Clicking the Install button installs the selected software.
- Exit — Clicking the Exit button closes the Application and Driver CD dialog box.

Once the Application and Driver CD dialog box appears, follow these steps to install the desired software.

1. Click the selection tab of your choice.
2. Select the desired application.
3. Click the Installation selection to activate the Install button.
4. Follow the on-screen instructions to install your selection.
5. Remove the CD from the CD-ROM drive when the installation is complete.

### ***Partition Magic***

Dividing a hard disk drive into several partitions lets you efficiently organize operating systems, programs, and data. PowerQuest's Partition Magic allows you to optimize hard disk drive space with an easy click of the mouse. Visually create, format, shrink, expand, and move hard disk partitions in minutes.

#### *Using Partition Magic*

Your NEC Versa notebook computer ships with an internal hard disk drive consisting of a single FAT 32 partition, drive C: (Windows 95 only). Use Partition Magic to create multiple partitions and convert any of all of these to FAT 16 on the hard disk drive.

---

**CAUTION**

Before using Partition Magic refer to the associated cautionary notes on the Application and Driver CD. The cautionary notes contain important information about designating the partitions on the hard disk drive as primary and/or extended.

The partitions must be properly designated before using the Product Recovery CD to reinstall your operating system. *If the partitions on the hard disk drive are not properly designated, it will appear as though data loss has occurred after using the Partition Restore Choice on the Product Recovery CD.*

---

After using Partition Magic to create multiple partitions on your hard disk drive, you must perform a partial restore using the Product Recovery CD for Windows 95. The partial restore process reinstalls the operating system and related drivers to drive C:.

### ***Intel LANDesk Client Manager***

Intel LANDesk Client Manager provides the capability for managing a variety of components within a PC system. These components include network interface cards, memory modules, printers, and software applications. LANDesk Client Manager uses the Desktop Management Interface (DMI) standard established by the Desktop Management Task Force (DMTF).

---

 **Note:** Intel LANDesk Client Manager continuously monitors your system for optimal system performance. This monitoring function interrupts the auto suspend feature that invokes after 30 minutes of inactivity.

If you install Intel's LANDesk Client Manager, the NEC Versa auto suspend feature may be disabled.

---

Set up the LANDesk Client Manager software on your NEC Versa using the easy-to-follow setup program. Follow these installation suggestions when installing LANDesk Client Manager.

- To install on a user's system, run Client setup, only.
- To install on a system administrator's system, run Client setup first, then run Administration setup. Installing both components enables the administrator to monitor his/her own system, as well as, all network systems. To monitor network systems only, run Administration setup, only.

If you use the NEC Versa system with the NEC Versa Dock and want to install LANDesk Client/Admin Manager, you must load the applicable software *before* docking the system.

---

To find out more about Intel LANDesk Client Manager capabilities and uses, refer to the online help that is available when you open Client Manager.

---

 **Note:** During the setup and installation of LANDesk Client Manager, you may be prompted to install Microsoft's Internet Explorer. Be sure to install Internet Explorer before installing LANDesk Client Manager.

After Internet Explorer is installed you must run the LANDesk Client Manager setup program again.

---

## ***SystemSoft PowerProfiler***

SystemSoft PowerProfiler for Windows NT lets you manage power resources, balancing performance with battery conservation. You can group power management settings into “profiles” for best performance and best conservation. You can also create custom profiles. PowerProfiler provides status information, alarms, and timers that let you easily monitor and control power consumption.

Access PowerProfiler through the Start, Programs menu.

## ***SystemSoft CardWizard***

SystemSoft CardWizard for Windows NT provides limited plug and play capability by automatically diagnosing and resolving many PC card problems.

When you insert a new PC card into a PC card slot, the Wizard displays a representation of the slot with information about the new card. If there are problems, in most cases, the Wizard automatically fixes them. Typical problems that are resolved include incorrect or missing drivers, system resource conflicts, unconfigured network and ATA cards, and memory conflicts.

Access CardWizard through the Start, Programs menu.

## ***Intellisync 97 or Intellisync for Notebooks***

Intellisync 97 or Intellisync for Notebooks is a powerful PC-to-PC synchronization solution that enhances your productivity by letting you synchronize all your key data. With Intellisync 97 or Intellisync for Notebooks you can:

- Synchronize files, drives, and directories on two computers, or in different partitions on a single computer.
- Synchronize data between two Personal Information Managers (PIMs).
- Copy and move files on a remote system using an infrared device or a parallel or serial cable.
- Control access each remote system has to your data.

Before using Intellisync 97 or Intellisync for Notebooks for infrared transfer, enable the IR port on your NEC Versa.

---

Before using Intellisync 97 or Intellisync for Notebooks for parallel or serial communication, connect the appropriate cable to the appropriate port on the back of your NEC Versa.

For more information about Intellisync 97 or Intellisync for Notebooks refer to the online manual.

### ***McAfee VirusScan***

The McAfee VirusScan software detects, identifies, and disinfects known computer viruses. It checks memory as well as both system and data areas of your disks for virus infections. In most cases, it eliminates and fully repairs infected programs or system areas to their original condition.

Access McAfee VirusScan through the Start, Programs menu.

### ***Microsoft Internet Explorer***

Microsoft's Internet Explorer makes finding information on the Internet easy. Built-in webcasting features give you the content you want, when you want it. An integrated set of tools provides services ranging from basic email to exciting conferencing, broadcasting, and web-authoring capabilities.

### ***Netscape Navigator***

Netscape Navigator is a popular software for browsing information on intranets or the Internet. Information tools simplify access to favorite sites and provide one-click access to Internet searches.

Navigator's features include technology that allows you directly manipulate and move images and Java applets to create visually exciting, fully interactive pages. In addition, Navigator lets you customize for individual preferences and bookmark favorite web sites to facilitate repeated access.

### ***Adobe Acrobat Reader***

Adobe Acrobat Reader allows you to view, navigate, and print PDF files from your local hard drive, your local network, or the Internet. For Windows NT only, Adobe Acrobat Reader is installed with the installation of Intel LANDesk Client Manager.

### ***Enabling the IR Port***

Procedures for enabling the IR port for Windows 95 and Windows NT systems differ. See the instructions appropriate for your system.

---

## Windows 95 Systems

In Windows 95, enable the IR port using the IR port setup utility accessible through the NEC Customize icon. Follow these steps to enable the IR port.

1. Double click the NEC Customize icon.
2. From the display window, select Install IR Setup utility.
3. Click Launch to initiate the IR Setup utility.

The IR Setup utility window displays.

4. Select Enable and click OK.

A message displays indicating that you must reboot your system TWICE to fully enable the IR port.

5. Click OK to reboot your system. *Be sure to reboot your system a second time before attempting to use the IR port for infrared communication.*
6. Click Exit to close the NEC Customize utility window.

## Windows NT Systems

In Windows NT, enable the IR port using the hardware BIOS setup utility. Follow these steps to enable the IR port.

1. Access the BIOS Setup utility at power-on. Just press **F2** when a prompt similar to the following appears.

Press <F2> to enter Setup

The BIOS Setup main menu appears.

2. Use the down arrow key to select the Peripheral Setup menu.
3. Use the down arrow key to select the IR Serial Port.
4. Use the **PgUp/PgDn** keys to change the default value to COM4, IRQ3. (Be sure to check your available resources before making a selection.)
5. Press **ESC** to return to the BIOS main menu.
6. Save your settings and exit the BIOS Setup utility.

For the infrared technology to work, you need to follow these guidelines:

- Position the NEC Versa no more than three feet way from the IR peripheral device you are using.
- Make sure there is no greater than a 30° angle between the computer and the device.



# 3

## Disassembly and Reassembly

- Required Tools and Equipment
- Disassembly
- Reassembly

---

## Required Tools and Equipment

All NEC Versa LX corrective maintenance procedures can be performed using the following tools:

- Tweezers
- Small flat-head screwdriver
- Small Phillips screwdrivers (# 1 and # 0)
- Right-angled dentist style probe.

## Disassembly

This section contains step-by-step disassembly procedures for the system. Reassembly is the reverse of disassembly. Each procedure is supported by a simplified disassembly illustration to facilitate removal. The Illustrated Parts Breakdown and parts lists for the system unit are shown in Chapter 5.

For complete disassembly of the system, follow the disassembly instructions that follow.

---

 **Note:** The following instructions cover two slightly different disassembly procedures. Some earlier units did not have a user-removable hard drive. Follow the instructions carefully to properly disassemble the systems.

---

When disassembling the system unit, follow these general rules.

- Turn off the system and disconnect all power and all options, including the AC adapter (if connected) and battery packs (see the procedures that follow).
- Do not disassemble the system into parts that are smaller than those specified in the procedure.
- Label all removed connectors. Note where the connector goes and in what position it was installed.

---

 **Note:** Do not interchange boards between non-AGP and AGP systems.

---

## Battery

Remove the battery pack installed in the NEC Versa LX system as follows.

---

 **Note:** Use the batteries in the NEC Versa computer for which they are designed. Also, installing another manufacturer's battery, or using a combination of very old and new batteries can deteriorate battery and equipment performance.

---

- 
1. Slide the battery release latch toward the back of the system and hold firmly.

### ***Battery Release Latch***

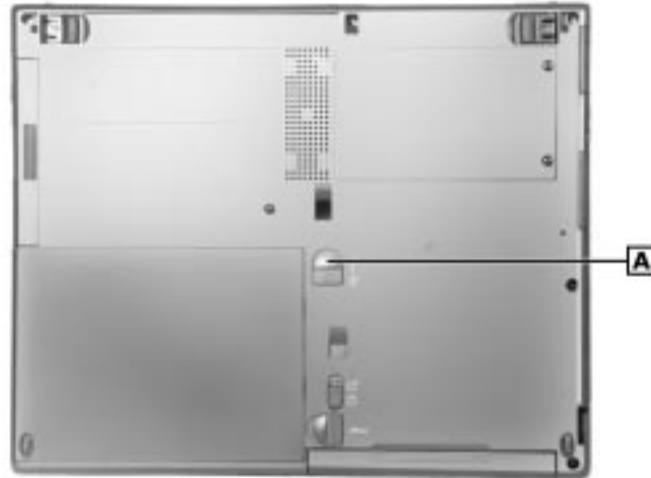

A – Battery Bay Release Latch

2. Continue to hold the battery release latch as you slide the battery out of the system.

### ***Removing the battery***



---

## ***Removing a Device from the VersaBay III***

Use the following steps to remove a device from the VersaBay III.

1. Locate the VersaBay III release lock and release latch on the bottom of the unit.

### ***VersaBay III release lock***

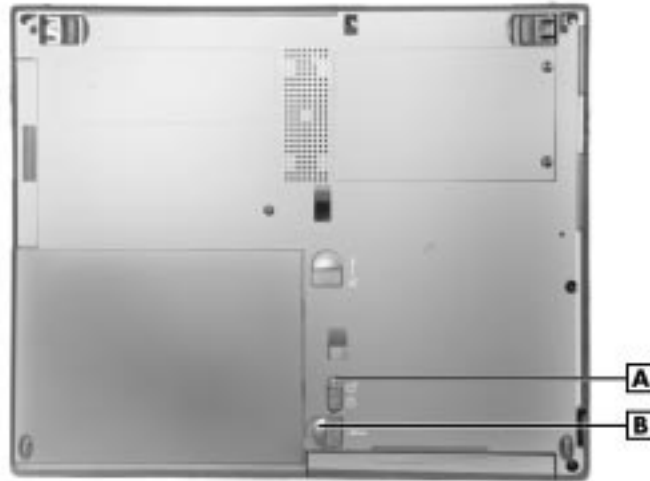

**A** – VersaBay Release Lock    **B** – VersaBay Release Latch

2. Slide the lock to the unlocked position before releasing the latch.
3. Slide the latch toward the battery bay and hold it.
4. Slide the device from the system.

---

 **Note:** If you release the latch before completely removing the device, the device casing catches on the inside of the latch.

---

### ***Releasing the device***

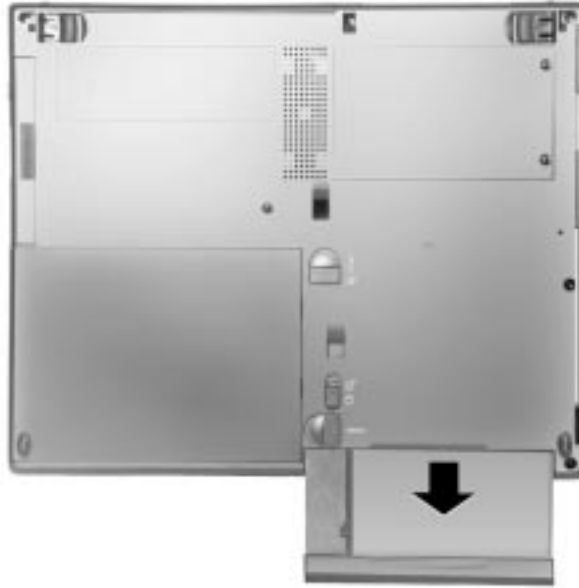

### ***Keyboard, Memory Module, Switch Settings***

Use the following steps to access/remove keyboard, memory and switch settings.

1. Open the LCD panel.
2. Locate the two keyboard retainers, apply pressure to the ridged area and slide each one toward the outside edge of the system and remove.

### ***Removing the keyboard retainers***



- 
3. Gently lift up the edge of the keyboard nearest the LCD and slide the keyboard toward the LCD screen to release the tabs that secure it.

#### ***Positioning the keyboard***



4. Carefully turn over the keyboard and place it face down on the VersaGlide. Be careful not to twist the keyboard cable. Remove the keyboard cable from the main board by pulling up on the inserts on both sides of the cable connector.

To remove an installed SO-DIMM, follow these instructions.

- Press the locking tabs away from the sides of the SO-DIMM and hold while gently lifting on the edge of the SO-DIMM.
- When the edge of the SO-DIMM pops up and is at approximately a 60 degree angle, pull the SO-DIMM from the socket.

#### ***Removing an installed SO-DIMM***

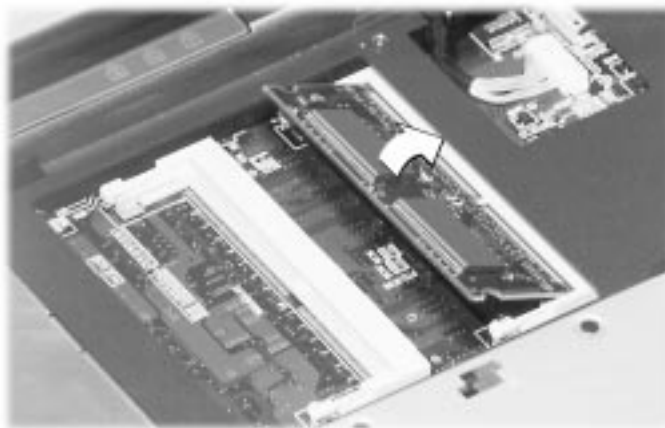

---

 **Note:** The system switches are also located underneath the keyboard. Therefore, if you need to set any system switches, do it while the system is already disassembled.

---

### *Switch Settings for Non-AGP Models*

The non-AGP system has a four-position dip switch dip switch. Follow the instructions below for changing dip switch settings.

A four-position dip switch is located underneath the keyboard. The following list identifies each switch setting and its function.

- Switch 1, Password Override Switch — The default setting is “OFF.” If you forget your password and cannot access the data on your NEC Versa, change the setting to “ON” and your current password dissolves.
- Switch 2 — Keyboard select; Default is “ON” for U.S. and Canada 85 key keyboard.
- Switch 3 — Reserved for factory use; Default is “OFF.”
- Switch 4 — Reserved for factory use; Default is “OFF.”

#### ***Default Switch Settings (Non-AGP Models)***



### *Switch Settings for AGP Models*

The AGP system has a six-position dip switch. Follow the instructions below for changing dip switch settings.

A six-position dip switch is located underneath the keyboard. The following list identifies each switch setting and its function.

- Switch 1, Password Override Switch — The default setting is “OFF.” If you forget your password and cannot access the data on your NEC Versa, change the setting to “ON” and your current password is erased.
- Switch 2 — Keyboard select; Default is “ON” for U.S. 85-key keyboard.
- Switch 3 — Reserved for factory use; Default is “ON.”
- Switch 4 — Keyboard select; Default is “ON” for U.S. 85-key keyboard.
- Switch 5, BIOS Flash Enable Switch — Default is “OFF”(disable). Before updating the BIOS, change the setting to “ON.”
- Switch 6 — Logo select; Default is “OFF” for U.S.

---

### **Default Switch Settings (AGP Models)**



#### **Changing Switch Settings**

Use the following steps to change switch settings.

1. Make sure the system is powered off and that no peripheral devices are attached.
2. Open the LCD panel.
3. Locate the two keyboard retainers, slide each one towards the outside edge of the system, and remove them.
4. Gently lift up the edge of the keyboard nearest the LCD and slide the keyboard toward the LCD screen to release the tabs that secure it.



#### **CAUTION**

Never use a pencil to change switch settings. Residue from the pencil can damage the system.

---

5. Gently rest the keyboard on top of the base unit to view and access the dip switch block. Be careful not to twist or disconnect the keyboard cable.
6. Locate the dip switch block. Using a fine-tipped object, change the appropriate switch to the required setting. See “Switch Settings” for dip switch functions and settings.



---

**Password Override Switch set to On (AGP Models)**



---

 **Note:** The system memory expansion slots are also located underneath the keyboard. If you need to install/replace SO-DIMM modules, do it while the system is already disassembled.

---

### **Disassembly Differences**

You must determine at this time, if the system you are servicing has a user removable hard disk drive. Determine if the hard disk drive is user replaceable by comparing the system with the following illustration.

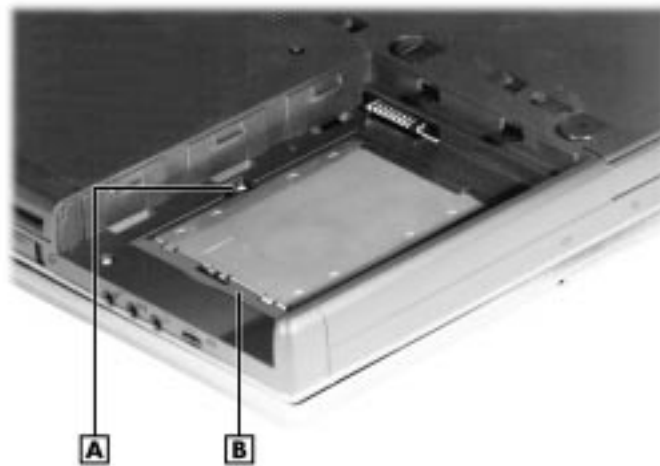

**A** - Screw

**B** - Hard disk drive lever

---

If the system you are servicing has both the screw **(A)** and hard disk drive lever **(B)** as shown in the previous illustration you have a user replaceable hard disk drive. Continue the disassembly process by going to the next set of instructions.

If the system does not have both of these items you have a system with a non-user replaceable hard disk drive. Skip to the section titled, “Disassembly of a Non-User Replaceable Hard Disk Drive.”

---

 **Note:** The system model number, on the back of the system, can identify a system with a user-replaceable hard disk drive. If the model number has the letter “A” in the next to last position of the number, the unit has a user-replaceable hard disk drive.

---

## ***Disassembly – User Replaceable Drive System***

Use the following procedures to disassemble the user-replaceable hard disk drive system.

### ***CPU Assembly***

Remove the CPU assembly as described below. It is recommended to use a special insertion/extraction tool to remove the CPU assembly. For information about this tool contact your Intel representative.

1. Remove two screws **(A)** from the CPU bay cover on the bottom of the NEC Versa as shown in the following figure.

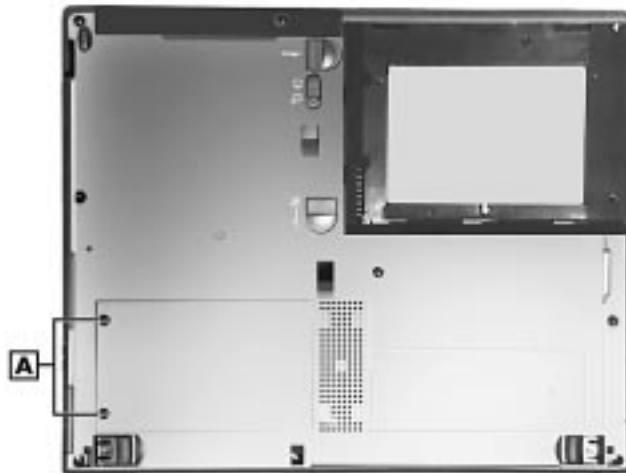

**A** – CPU Bay Cover Screws

2. Remove the CPU cover.

- 
3. Remove three screws (A) as shown in the following figure.

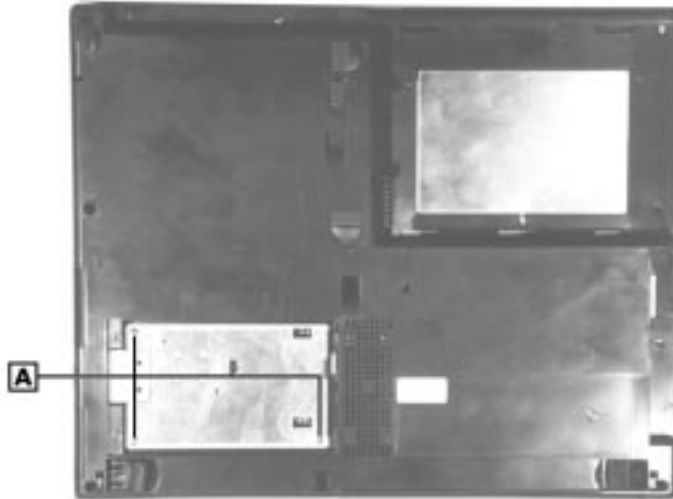

A – Screws

4. Lift and disconnect the CPU assembly from the unit.

### ***File Bay Assembly***

Remove the file bay assembly as described below.

1. Remove one screw (A) from the bottom of the NEC Versa as shown in the following figure.

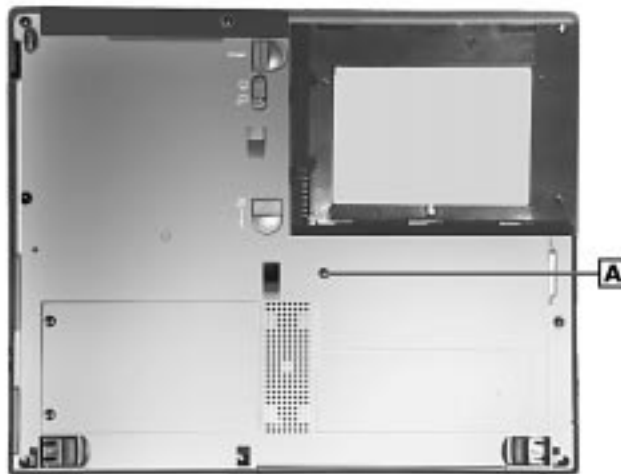

A – File Bay Screw

2. Slide the file bay assembly to the right and remove from the NEC Versa.

---

## Hard Disk Drive Assembly

Remove the hard disk drive assembly as described below.

1. Remove the screw (A) that secures the hard disk drive.
2. Place your finger in the center notch of the hard drive lever (B) and pull up the lever. Be sure that both sides of the lever are raised.

### *Hard Disk Drive in the drive bay*

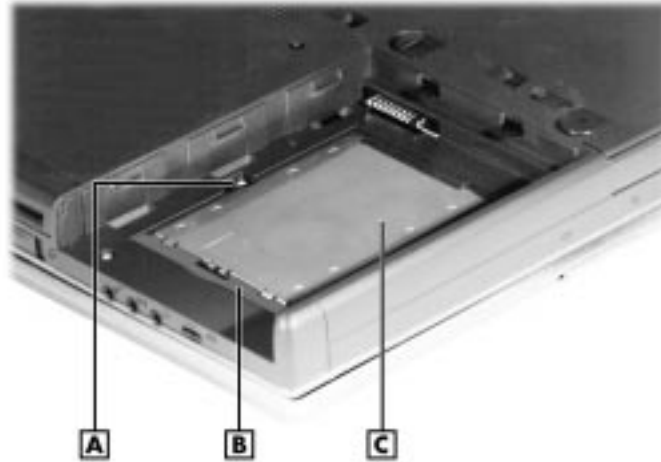

A – Screw    B – Hard Disk Drive Lever    C – Hard Disk Drive

3. With the lever raised, place your fingers on the inside edge of the lever and on each side of the center notch. Pull the drive toward the open side of the battery bay. Do not apply pressure to the drive surface as you pull.

### *Disconnecting the drive*



- 
4. Once the drive is disconnected, use the lever to lift the drive out of the system. Once removed, only handle the drive by its sides.

#### ***Lifting the drive out of the bay***



### **Front Cover**

The following describes the steps to remove the front cover.

1. The file bay retaining screw (**B**) on the bottom of the system should have been removed in a prior step. If not, remove it now.
2. Remove a total of 9 screws.
  - 5 from the bottom surface (**A**)
  - 1 from the VersaBay III (**A**)
  - 1 from the file bay (**A**)
  - 2 from the battery bay (**A**)

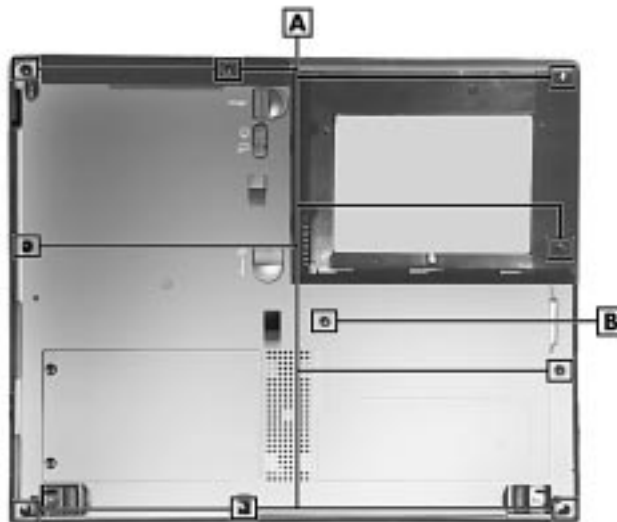

**A** – Bottom Screws      **B** – File Bay Screw

3. Turn the system over and open the LCD panel.

- 
4. Disconnect the VersaGlide cable from connector P11 (next to the dip switches) and speaker assembly cable from connector P10. Both are located on the main board.
  5. Carefully separate and lift the front cover from the bottom assembly, starting on the right and working left.

At this point in the disassembly sequence you can remove the speaker assembly, VersaGlide assembly or LCD panel latch switch assembly, if necessary. If these items do not need replacing, skip the next section.

#### *Speaker Assembly, VersaGlide Assembly, LCD Panel Latch Switch Assembly*

1. Position the front cover assembly as shown in the following illustration.

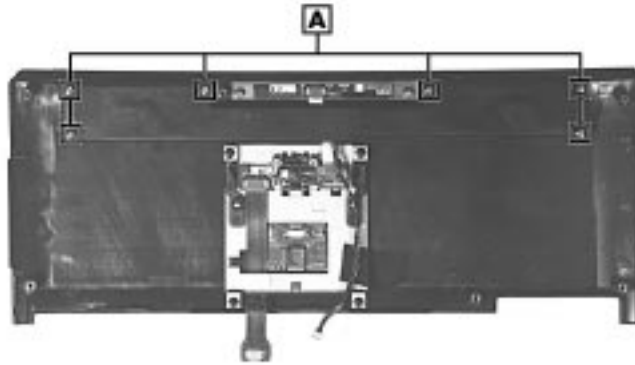

A – Speaker Assembly Screws

2. Remove the screws and lift the speaker assembly from the front cover assembly.

#### *VersaGlide Assembly*

Remove the VersaGlide and cable assembly instructions as follows.

1. Disconnect the LCD panel switch cable from connector CP16 (A) on the VersaGlide assembly.
2. Remove the four screws (B).

- 
3. Lift the VersaGlide assembly from the front cover assembly.

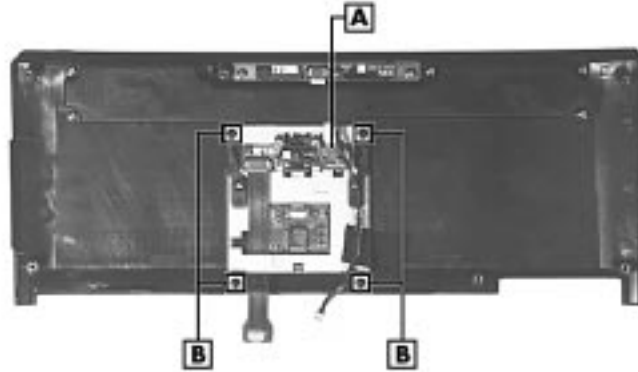

**A** – Connector CP16      **B** – VersaGlide Screws

### *LCD Panel Switch Board*

Remove the LCD panel switch board as follows.

1. Disconnect the LCD panel switch cable from connector CP17 (**B**) on the LCD panel latch switch board.
2. Remove 2 screws (**A**) and lift from the front cover assembly.

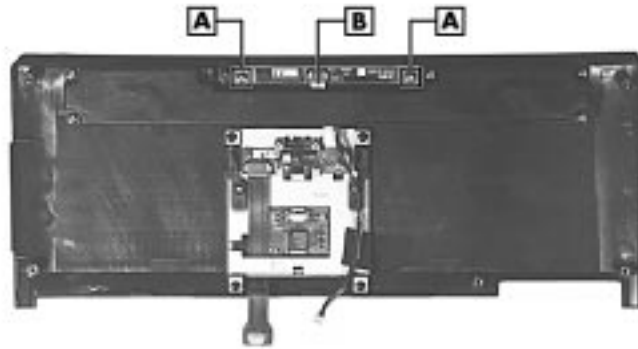

**A** – LCD Cover Panel Switch Board Screws      **B** – Connector CP17

This completes the disassembly of the front cover assembly. Reverse this procedure to properly reassemble.

### *LCD Panel Assembly*

Remove the LCD panel assembly as follows.

1. Disconnect cables from the LCD cable at P4 on the main board and the LED sub-assembly cable at connector P2.

- 
2. Remove two screws (**A**) and lift and separate the LCD panel assembly from the remainder of the system.

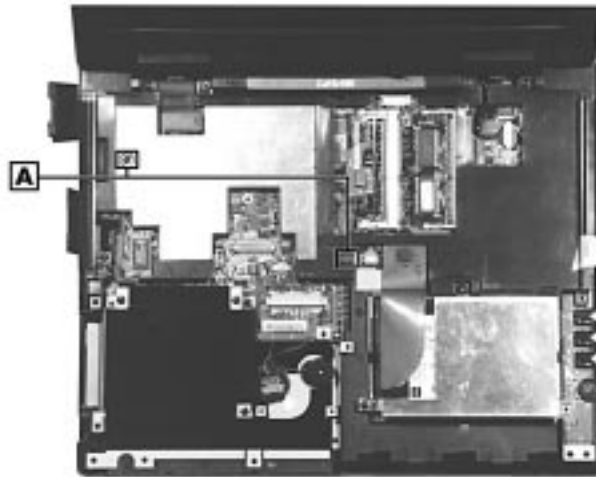

A – LCD Panel Assembly Screws

### *LED Sub Assembly*

The LED sub assembly consists of a board that contains three connectors and status LEDs. The connectors are for the LCD panel switch, main board, and microphone.

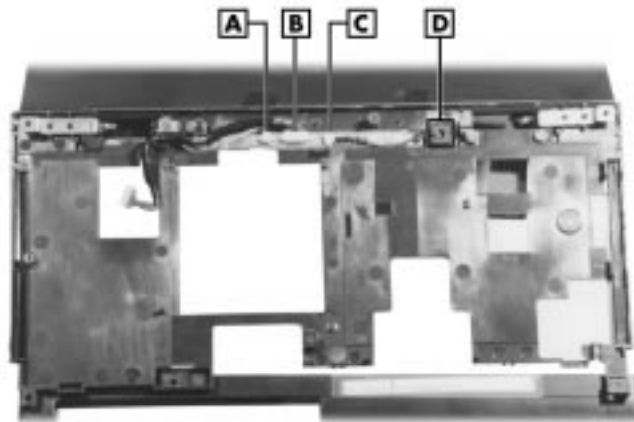

A – Connector CP13      B – Connector CP12  
C – Connector CP11      D – Microphone

### *LCD Panel Switch*

1. Remove two screws on the hinge bracket.
2. Disconnect the cable at connector CP13 on the LED board.



---

### *Microphone*

1. Disconnect the microphone cable at connector CP11.
2. Remove the microphone and cable by gently pulling from the LCD assembly.

### *LED Board and LED Board Cable*

1. Remove two screws and disconnect the cable from connector CP12 on the LED board.
2. Lift the LED board to remove.
3. Remove one screw to release the LED cable and anchor from the LCD panel assembly.

## ***PC Card Assembly, CMOS Battery, Buzzer, and Audio Board***

The PC card assembly, CMOS battery, buzzer, and audio board may be removed and replaced individually if need be, but all must be removed to continue the disassembly sequences to the next level.

### *PC Card Assembly*

1. Remove three screws (**A**).
2. Lift and disconnect the PC card assembly from connector P14 on the main board. Start by lifting on the right side of the PC card assembly and slide to the right.

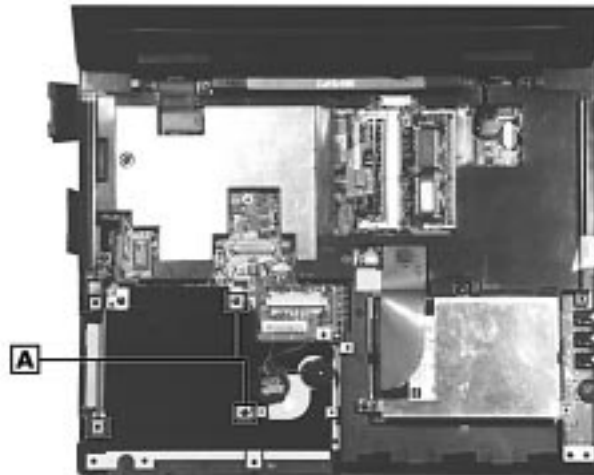

**A** – PC Card Assembly Screws

---

### CMOS Battery

1. Disconnect the CMOS battery cable from connector P28 on the main board.
2. The CMOS battery is held in place by double-sided pressure tape. Gently pry up to remove.

### Buzzer

1. Disconnect the buzzer cable from connector P29 on the main board.
2. Pry up to remove the buzzer assembly from its location.

### Main Board Assembly

1. Disconnect the bridge battery cable at connector P1 (A).
2. Remove one screw (B) and lift and remove the port cover plate.
3. Remove two screws (C) and disconnect the audio board (D) by gently lifting the front edge of the audio board and disconnecting from the main board.
4. Lift the main board from the remainder of the system.

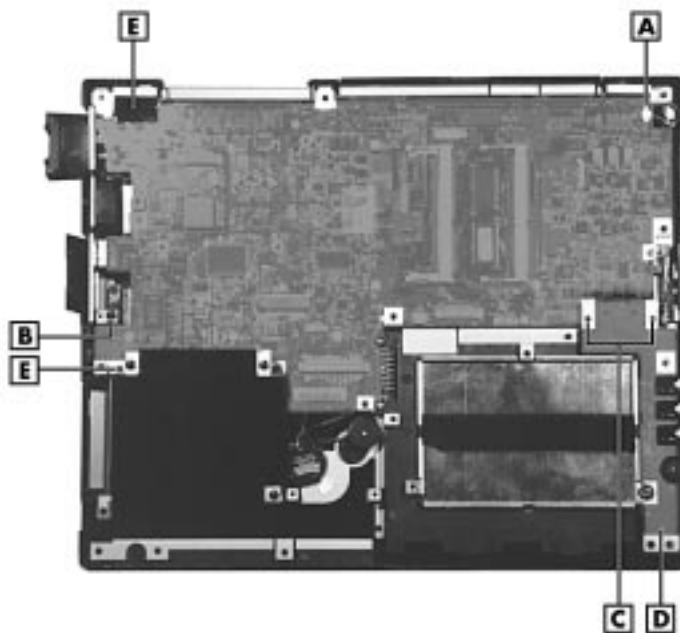

A – Connector P1    B – Port Cover Plate Screw    C – Audio Board Screws  
D – Audio Board    E – Main Board Screws

### Fan Assembly

The fan assembly is made up of a bracket and fan. Follow the steps below to remove.

1. Disconnect the fan cable at connector P5 on the main board.
2. Remove two screws (E) on the main board to release the fan assembly.

3. Slide the fan duct away from the fan to remove.
4. Remove two screws to release the fan from the bracket.

### *CPU Assembly*

If the CPU assembly was not removed, as described earlier you can remove it now as described next.

1. Turn the main board over so the bottom is facing up.
2. Remove three screws.
3. Lift and disconnect the CPU assembly from the main board. The heat shield and CPU board come off as two layered pieces.

### ***Bracket/Insulator Assemblies, Bridge Battery, Power Switch***

1. The bridge battery (**A**) is now accessible on the bottom assembly.
2. To remove the Power switch, simultaneous slide it to the front and gently lift the Power switch from the bottom assembly.
3. Remove both Bracket/Insulator assemblies by removing four screws (**B**) and lifting the Bracket/Insulator assemblies from the bottom assembly.

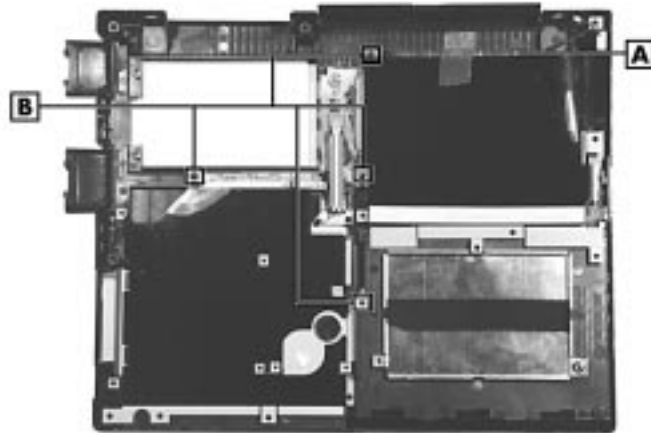

A – Bridge Battery    B – Bracket/Insulator Assembly Screws

### ***Connector Board, Switch/Cable Cover, Switch/Cable***

1. Remove one screw (**A**) to release the switch/cable cover.
2. Lift the switch/cable cover.
3. Disconnect the cable at connector CP8 (**B**) on the connector board and lift the switch/cable from the two locating pins.

- 
4. Remove one screw (**B**) to release the connector board from the bottom assembly.

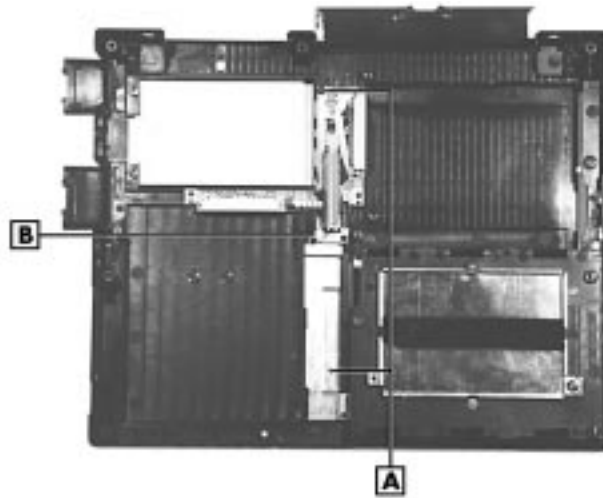

A – Screws

B – Connector CP8

### ***Bottom Base Assembly***

There are doors and tilt feet on the bottom assembly.

- All doors snap in and out.
- To remove the tilt feet open the foot and slightly compress the four sections together and snap out.

### ***Disassembly – Non-User Replaceable Drive System***

Use the following procedures to disassemble the non-user replaceable hard disk drive system.

### ***CPU Assembly***

Remove the CPU assembly as described in the following procedure.

- 
1. Remove two screws (**B**) from the CPU bay cover on the bottom of the NEC Versa as shown in the following figure.

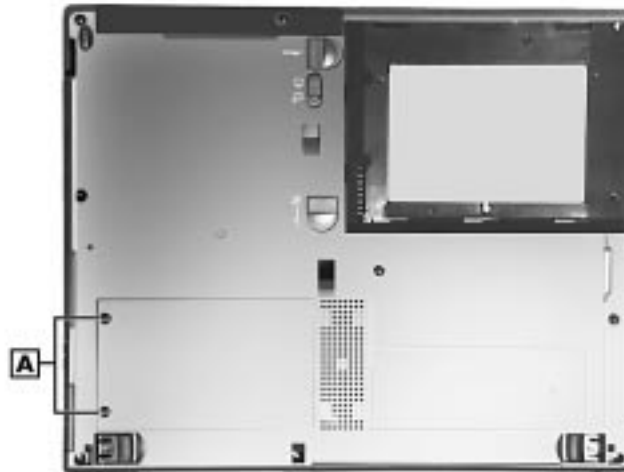

A – CPU Bay Cover Screws

2. Remove the CPU cover.
3. Remove three screws (**A**) as shown in the following figure.



A – Screws

4. Lift and disconnect the CPU assembly from the unit.

### **Front Cover**

The following describes the steps to remove the front cover.

1. Turn the system over with the bottom facing up.
2. Remove a total of 11 screws.
  - 6 from the bottom surface (**A**)

- 
- 1 from the VersaBay III (A)
  - 1 from the File Bay (A)
  - 3 from the battery bay (A)

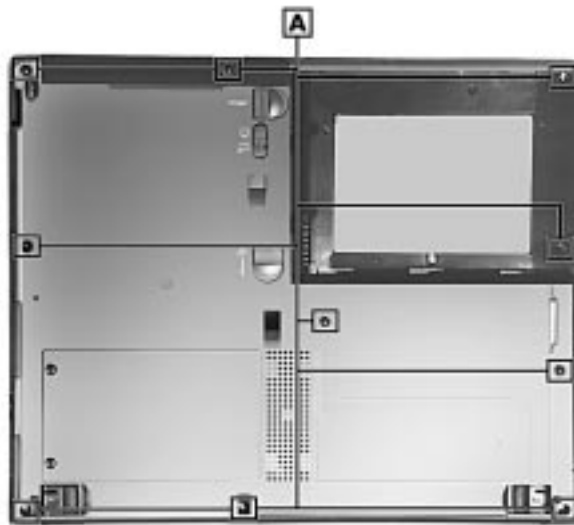

A – Bottom Screws

3. Turn the system over and open the LCD panel. Disassembly Sequence 1 (Battery Pack, VersaBay III Device and File Bay Device) and 2 (Keyboard) should be completed as described in previous sections of this chapter.
4. Disconnect the VersaGlide cable from connector P11 and speaker assembly cable from connector P10 both located on the main board.
5. Carefully separate and lift the front cover from the bottom assembly, starting on the right and working left.

At this point in the disassembly sequence you can remove the speaker assembly, VersaGlide assembly or LCD panel latch switch assembly, if necessary. If these items do not need replacing, skip the next section and go to the following sequence.

---

### *Speaker Assembly, VersaGlide Assembly, LCD Panel Latch Switch Assembly*

1. Position the front cover assembly as shown in the following illustration.

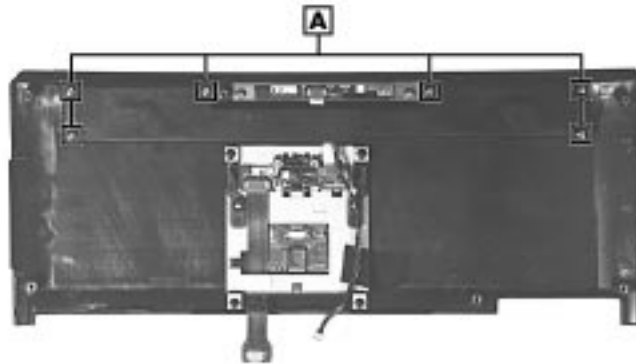

A – Screws

2. Remove the speaker assembly by removing 6 screws. Lift the speaker assembly from the front cover assembly.

### *VersaGlide Assembly*

Remove the VersaGlide and cable assembly instructions as follows.

1. Disconnect the LCD panel switch cable from connector CP16 (A) on the VersaGlide assembly.
2. Remove the four screws (B).
3. Lift the VersaGlide assembly from the front cover assembly.

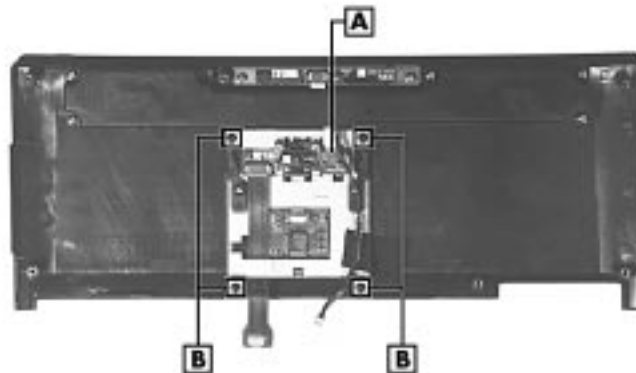

A – Connector CP16    B – Speaker Assembly Screws

### *LCD Panel Switch Board*

Remove the LCD panel switch boards instructions as follows.

1. Disconnect the LCD panel switch cable from connector CP17 (B) on the LCD panel latch switch board.

- 
2. Remove 2 screws (**A**) and lift from the front cover assembly.

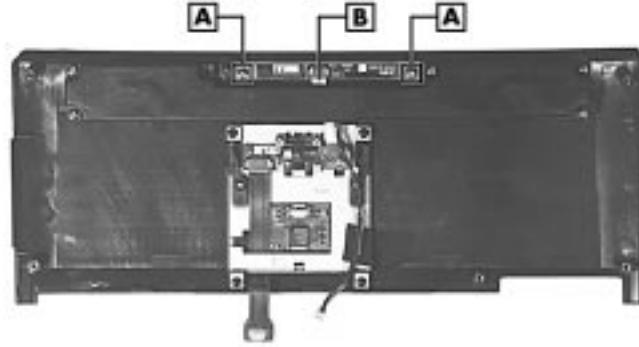

A – LCD Cover Panel Switch Board Screws    B – Connector CP17

This completes the disassembly of the front cover assembly. Reverse this procedure to properly reassemble.

### ***LCD Panel Assembly***

Remove the LCD Panel assembly as follows.

1. Disconnect cables from the LCD cable at P4 on the main board and the LED sub-assembly cable at connector P2.
2. Remove two screws (**A**) and lift and separate the LCD panel assembly from the remainder of the system.

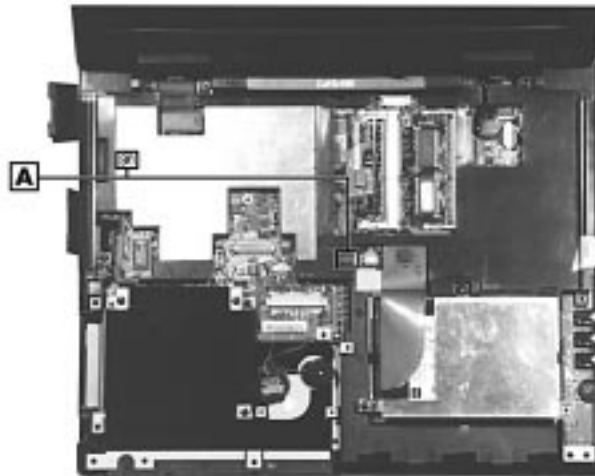

A – LCD Panel Assembly Screws



---

## LED Sub Assembly

The LED sub assembly consists of a board that contains three connectors and status LEDs. The connectors are for the LCD panel switch, main board, and microphone.

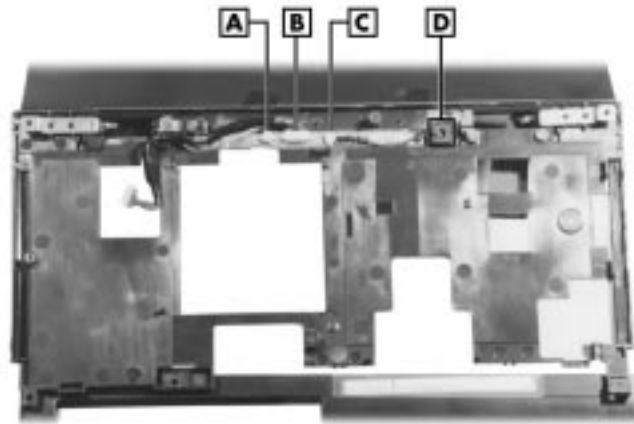

A – Connector CP13      B – Connector CP12  
C – Connector CP11      D – Microphone

### *LCD Panel Switch*

1. Remove two screws on the hinge bracket.
2. Disconnect the cable at connector CP13 on the LED board.

### *Microphone*

1. Disconnect the microphone cable at connector CP11.
2. Remove the microphone and cable by gently pulling from the LCD assembly.

### *LED Board and LED Board Cable*

1. Remove two screws and disconnect the cable from connector CP12 on the LED board.
2. Lift the LED board to remove.
3. Remove one screw to release the LED cable and anchor from the LCD panel assembly.

## **Hard Drive and PC Card Assemblies, CMOS Battery, Buzzer, Audio Board**

The hard drive assembly, PC card assembly, CMOS battery, buzzer, audio board may be removed and replaced individually or all must be removed to continue the disassembly sequences.

---

### *Hard Drive Assembly*

1. Disconnect the hard drive cable at connector P9 on the main board.
2. Remove three screws (A) and lift the hard drive assembly from the system.

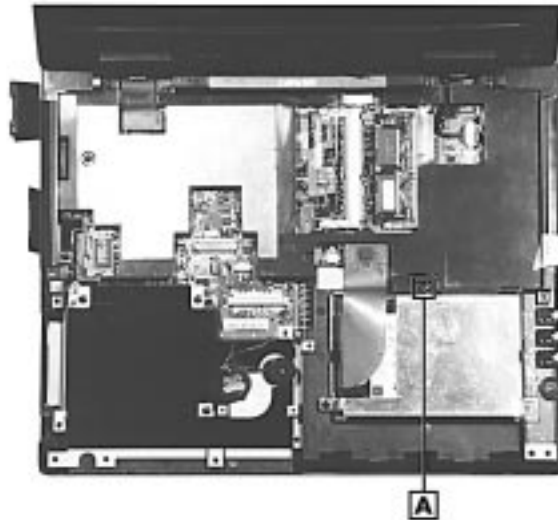

A – Hard Disk Drive Screws

### *PC Card Assembly*

1. Remove three screws (A).
2. Lift the PC card assembly from the right side of the system.

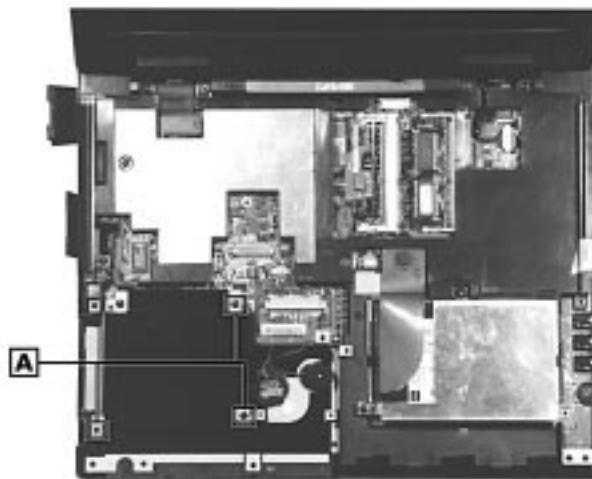

A – CPU Assembly Screws

### *CMOS Battery*

1. Disconnect the CMOS battery cable from connector P28 on the main board.
2. The CMOS battery is held in place by double-sided pressure tape. Gently pry up to remove.

---

## Buzzer

1. Disconnect the buzzer cable from connector P29 on the main board.
2. Pry up to remove the buzzer assembly from its location.

## Main Board Assembly

1. Remove the main board screws (**A**).
2. Disconnect the bridge battery cable at connector P1 (**B**).
3. Remove the one screw (**D**) and port cover plate.
3. Disconnect the audio board (**C**) by gently lifting the front edge of the audio board and disconnecting from the main board.
4. Lift the main board from the remainder of the system.

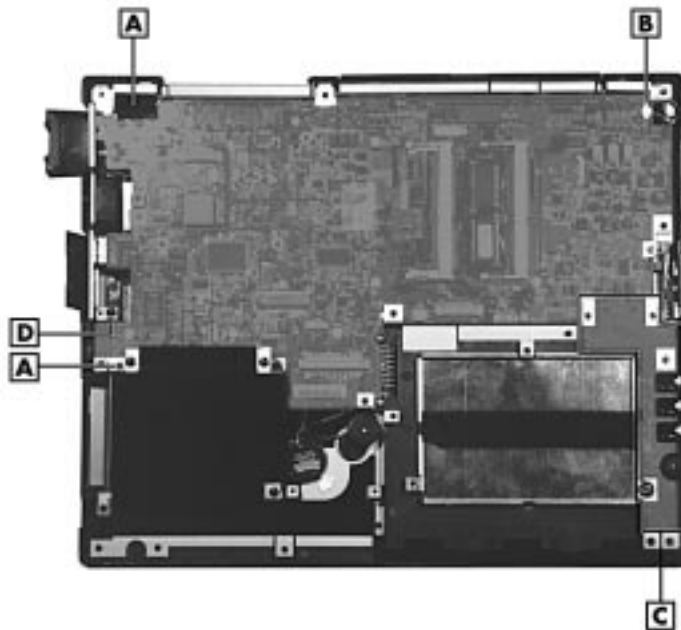

**A** – Main Board Screws  
**C** – Audio Board

**B** – Connector P1  
**D** – Port Cover Plate Screw

## Fan Assembly

The fan assembly is made up of a bracket and fan. Follow the steps below to remove.

1. Disconnect the fan cable at connector P5 on the main board.
2. Remove two screws (**D**) on the main board to release the fan assembly.
3. Remove two screws to release the fan from the bracket.

## CPU Assembly

The CPU assembly may also be removed from the bottom on the system, as described in Disassembly Sequence 3 (CPU Assembly).

- 
1. Turn the main board over so the bottom is facing up.
  2. Remove three screws.
  3. Lift and disconnect the CPU assembly from the main board. The heat shield and CPU board comes off as two layered pieces.

### ***Bracket/Insulator Assemblies, Bridge Battery, Power Switch***

1. The bridge battery (**B**) is now accessible on the bottom assembly.
2. To remove the Power switch, slide it to the front while at the same time gently lifting the power switch from the bottom assembly.
3. Remove the Bracket/Insulator assemblies by removing three screws (**A**) and lifting the Bracket/Insulator assemblies from the bottom assembly.

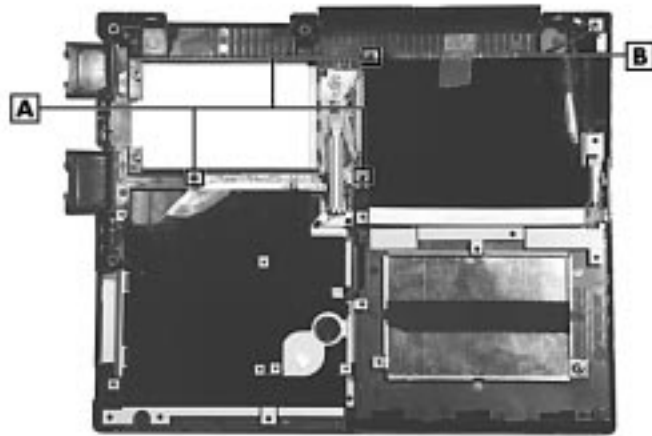

A – Bracket/Insulator Assembly Screws      B – Bridge Battery

### ***Connector Board, Switch/Cable Cover, Switch/Cable***

1. Remove one screw (**A**) to release the switch/cable cover.
2. Lift the switch/cable cover.
3. Disconnect the cable at connector CP8 (**B**) on the connector board and lift the switch/cable from the two locating pins.

- 
4. Remove one screw (A) to release the connector board from the bottom assembly.

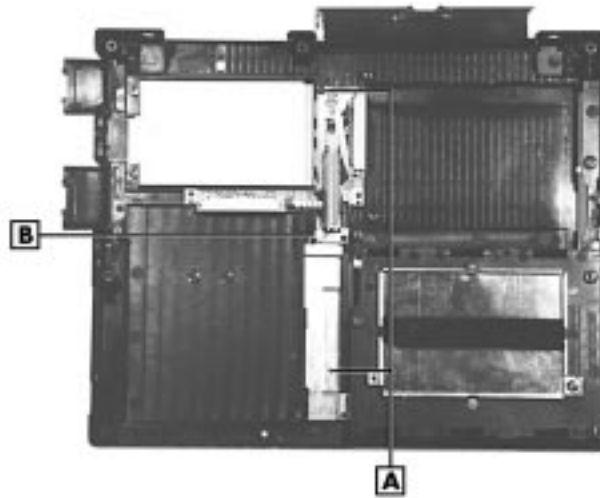

A – Screws

B – Connector CP8

### ***Bottom Base Assembly***

There are doors and tilt feet on the bottom assembly.

- All doors snap in and out.
- To remove the tilt feet open the foot and slightly compress the four sections together and snap out.

### ***Reassembly***

Reassembly is the reverse of the disassembly process. Use care to insure that all cables and screws are returned to their proper positions.

# 4

## System Board Layout

- Audio Board
- Connector Board
- LCD Panel Switch Board
- LED Status Board
- Main Board

---

## Audio Board

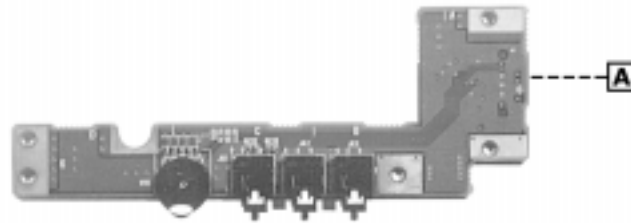

A – Connector P31 (underside)

## Connector Board

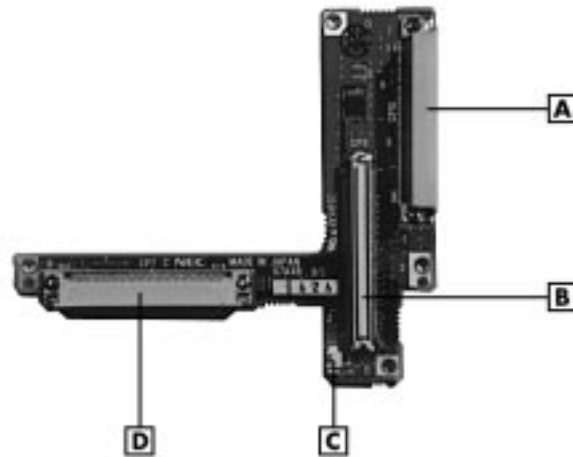

A – Connector CP10      B – Connector CP9  
C – Connector CP8      D – Connector CP7

---

## ***LCD Panel Switch Board***

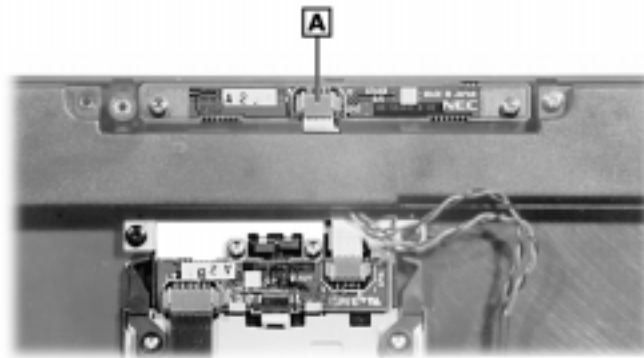

A – Connector CP17

## ***LED Status Board***

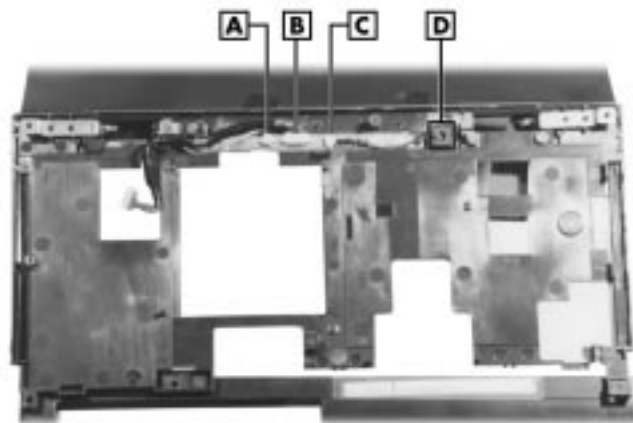

A – Connector CP13      B – Connector CP12  
C – Connector CP11      D – Microphone



---

## Main Board

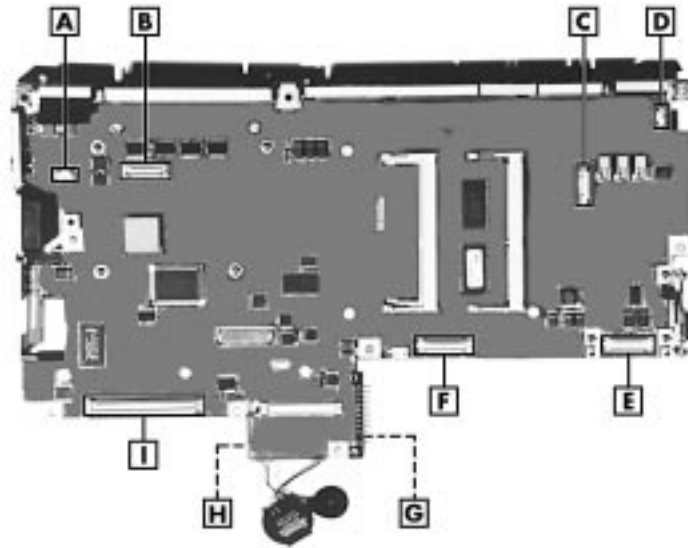

**A** – Connector P5

**D** – Connector P1

**G** – Connector P28 (underside)

**B** – Connector P4

**E** – Connector P8

**H** – Connector P29 (underside)

**C** – Connector P2

**F** – Connector P9

**I** – Connector P14

# 5

## Illustrated Parts Breakdown

- Illustrated Parts Breakdown (Non-AGP Models)
- Parts List (Non-AGP Models)
- Illustrated Parts Breakdown (AGP Models)
- Parts List (AGP Models)

# Illustrated Parts Breakdown (Non-AGP Models)

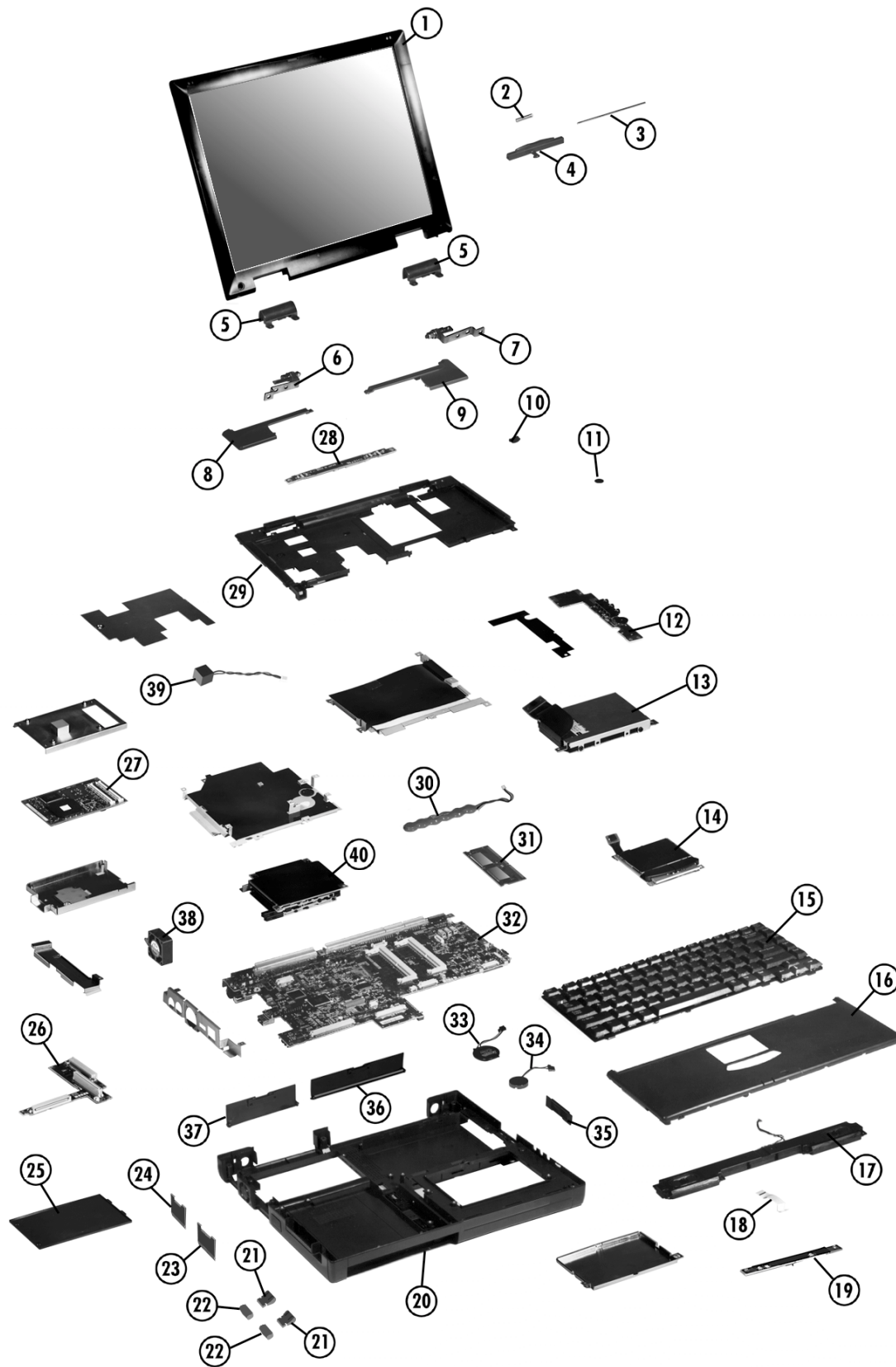

5-2 Illustrated Parts Breakdown

---

## Parts List (Non-AGP Models)

The following table contains a listing of the field-replaceable parts and corresponding part numbers for non-AGP models.

### *Field-Replaceable Parts List*

<b>Item</b>	<b>Description</b>	<b>Part Number</b>
1	LCD Panel Sub Assembly 12.1 - inch 13.3 - inch 14.1 - inch	158-057557-000 158-057558-000 158-057559-000
2	LCD Lock Spring	136-628895-A
3	LCD Lock Shaft	136-636754-A
4	LCD Lock Lever	136-639307-001A
5	Hinge Cap	136-639511-001A
6	Tilt Unit (left)	808-811158-001A
7	Tilt Unit (right)	808-811158-002A
8	Corner Cap (L)	136-639512-001A
9	Corner Cap (R)	136-639512-002A
10	LCD Rubber Cushion	136-639309-001B
11	Screw Hole Cover	136-639310-001A
12	Audio Board	136-243483-001A includes items # 23 & 24
13	Hard Drive Assembly 2GB 3GB 5GB	808-877280-304A 808-877329-124A 808-877329-304A
14	Glide Point Sub Assembly FRU	158-057555-000
15	Keyboard V105(US)	808-897300-501A
16	Front Cover Assembly without Glide Point	136-243484-001A
17	Speaker Cable Assembly	808-878090-001A
18	LED/Glide Point Cable	808-742980-002A
19	LED Package (Front) Sub Assembly	136-243472-001A
20a	Bottom Base Assembly	136-243458-001A
20b	Bottom Base Assembly (removable hard disk drive)	136-243684-001A
21	Tilt Foot	136-639509-001A
22	Rubber Foot	136-639531-001A
23	USB Cap	136-243477-001A
24	TV Cap Assembly	136-243476-001A
25	CPU Cap	136-639508-001A

### **Field-Replaceable Parts List**

<b>Item</b>	<b>Description</b>	<b>Part Number</b>
26	Connector Board (VersaBay III, File Bay)	136-243459-001A
27	CPU Board	
	TM200	158-057553-003
	TM233	158-057553-004
	MD233	158-057553-002
	MD266	158-057553-001
	MD300	158-057553-005
28	LED Package for Sub Assembly (F)	136-243472-001A
29a	Keyboard Cover	136-639510-001A
29b	Keyboard Plate	136-639492-A
30	Bridge Battery	804-021205-004A
31	Memory Module	136-243655-001A
	32MB SO-DIMM	136-243655-002A
	64MB SO-DIMM	
32	Main Board Assembly	136-243463-001A
33	Battery Lithium VL23205 (CMOS)	804-020804-009A
34	Buzzer	802-870076-001A
35	Power Switch	136-639535-001A
36	I/O Cap Assembly	136-243478-001A
37	Docking Station Cap Assembly	136-243479-001A
38	Fan 25 (2510-5V)	808-876290-002A
39	Microphone	808-876316-001A
40	PCMCIA Package Sub Assembly	136-243464-001A
*	AC Adapter	808-892246-002A
*	AC Cable	158-057544-000
*	VersaGlide Cable	808-877610-001A
*	Battery Li-Ion BL108362	804-201458-002A
*	Battery Li-Ion BL108482	804-021456-001A
*	CD-ROM (24X Toshiba) Pack Assembly	136-243444-001A or OP-260-69001
*	DVD Drive Pack	OP-270-69001
*	FDD Pack FRU Assembly	158-057556-000A
*	Hard Drive FPC Assembly	808-877607-001A
*	Heat Sink (T)	136-639477-A
*	Heat Sink (DF)	136-639545-A or 136-243661-001A
*	Logo Name Plate (Versa LX)	136-640395-001A
*	SuperDisk FDD Pack	136-243475-001B

\* Item not shown on IPB.

#### **5-4 Illustrated Parts Breakdown**

# Illustrated Parts Breakdown (AGP Models)

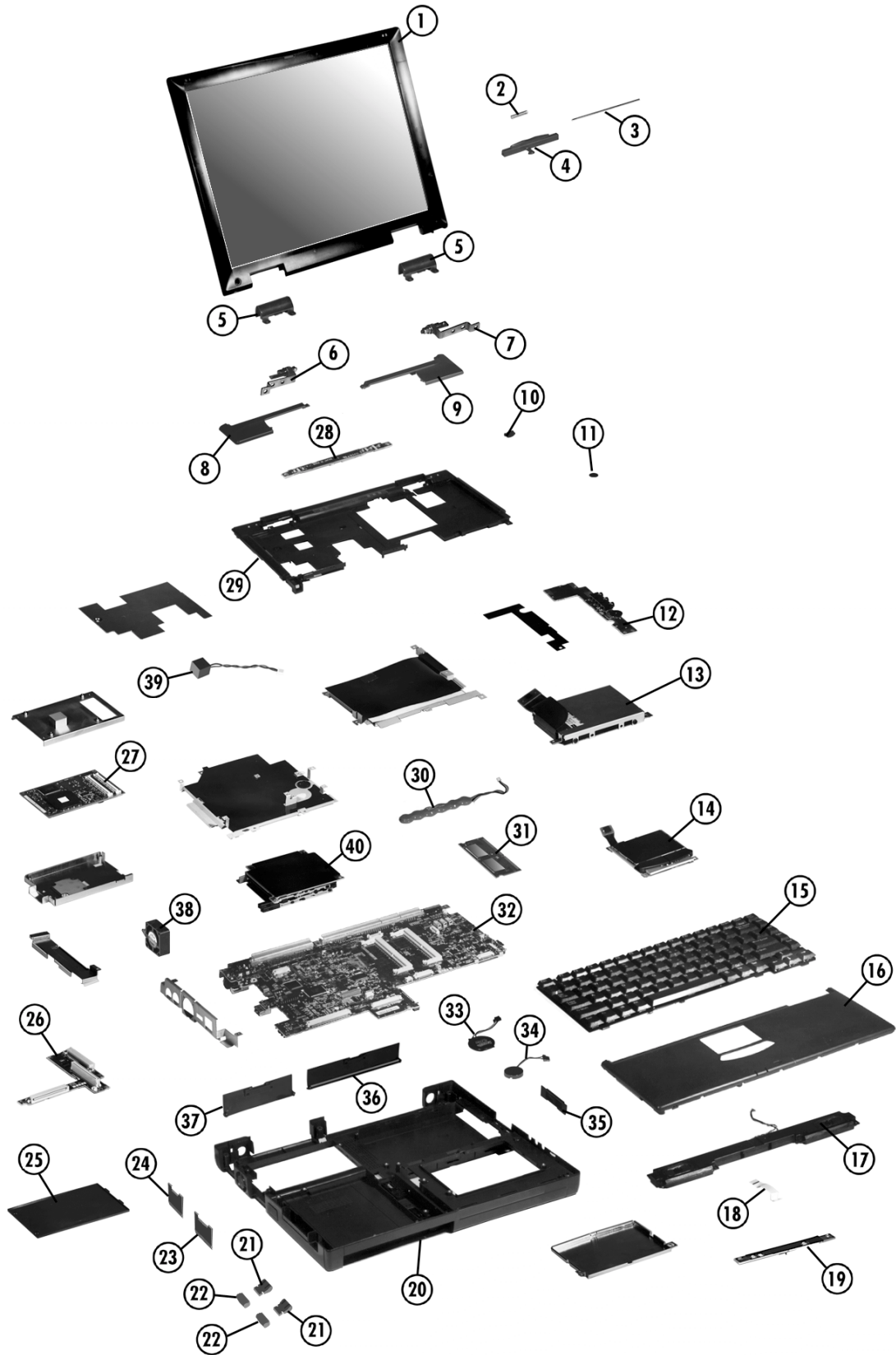

---

## Parts List (AGP Models)

The following table contains a listing of the field-replaceable parts and corresponding part numbers for AGP models.

### *Field-Replaceable Parts List*

<b>Item</b>	<b>Description</b>	<b>Part Number</b>
1	LCD Panel Sub Assembly 13.3 - inch 14.1 - inch	136-243683-005B 136-243683-004B
2	LCD Lock Spring	136-628895-A
3	LCD Lock Shaft	136-636754-A
4	LCD Lock Lever	136-639307-001A
5	Hinge Cap	136-639511-001A
6	Tilt Unit (left)	808-811158-001A
7	Tilt Unit (right)	808-811158-002A
8	Corner Cap (L)	136-639512-001A
9	Corner Cap (R)	136-639512-002A
10	LCD Rubber Cushion	136-639309-001B
11	Screw Hole Cover	136-639310-001A
12	Audio Board	136-243483-002A
13	Hard Drive Assembly 3 GB 4 GB 6 GB 10 GB	050-01649-000 050-01651-000 050-01650-000 050-01652-000
14	Glide Point Sub Assembly FRU	158-057555-000
15	Keyboard V105(US)	808-897300-501A
16	Front Cover Assembly without Glide Point	136-243484-001D
17	Speaker Cable Assembly	808-878090-001A
18	LED/Glide Point Cable	808-742860-008A
19	LED Package (Front) Sub Assembly	136-243472-001A
20	Bottom Base Assembly	136-243684-001A
21	Tilt Foot	136-639509-001A
22	Rubber Foot	136-639531-001A
23	USB Cap	136-243477-001A
24	TV Cap Assembly	136-243476-001A
25	CPU Cap	136-639508-001C
26	Connector Board (VersaBay III, File Bay)	136-243459-001A

---

### **Field-Replaceable Parts List**

<b>Item</b>	<b>Description</b>	<b>Part Number</b>
27	CPU Board	
	MMC2 300	802-143380-705A
	MMC2 333	802-143380-706A
	MMC2 366	802-143380-707A
	MMC2 400	802-143380-708A
28	LED Package for Sub Assembly (F)	136-243472-001A
29	Keyboard Bay	136-639510-001A
29b	Keyboard Plate	136-639492-A
30	Bridge Battery	804-021205-004A
31	Memory Module	
	32MB SO-DIMM	136-243655-001A
	64MB SO-DIMM	136-243655-002A
32	Main Board Assembly	136-553998-001B
33	Battery Lithium VL2320-S7F (CMOS)	804-020804-009A
34	Buzzer	802-870076-001A
35	Power Switch Button	136-639535-001A
36	I/O Cap Assembly	136-243478-001A
37	Docking Station Cap Assembly	136-243479-001C
38	Fan 25 (2510-5V)	808-876290-003A
39	Microphone	808-876316-003A
40	PCMCIA Package Sub Assembly	136-243464-101A
*	AC Adapter	808-892246-002A
*	AC Cable	158-057544-000
*	VersaGlide Cable	808-877610-001A
*	Battery Li-Ion BL108482	804-021456-001A
*	CD-ROM (24X Toshiba) Pack Assembly	136-243444-002A or OP-260-69001
*	DVD Drive Pack	136-243283-001A or OP-270-69001
*	FDD Pack FRU Assembly	158-057556-000A
*	Hard Drive FPC Assembly	136-244455-001A
*	Heat Sink Assy	136-243661-001A
*	Logo Name Plate (Versa LX)	136-640395-001A
*	SuperDisk FDD Pack	136-243475-002D
*	Close Off Switch	808-743156-001A
*	Lock Bracket	136-639544-A
*	FDD Plate Assembly	136-243460-001A



---

### ***Field-Replaceable Parts List***

<b>Item</b>	<b>Description</b>	<b>Part Number</b>
*	Bay Plate Assembly	136-243461-001B
*	Earth Plate	136-639527-A
*	Top Cover Assembly	136-243469-002A
*	LED Cable Assembly	808-743297-001A
*	HDD Frame	050-01648-000
*	Weight Saver Pack	136-641008-001A

\* Item not shown on IPB.

# 6

## Preventive Maintenance

- Cleaning the Notebook Exterior
- Cleaning the Notebook Interior
- Protecting Disk Drive
- Handling the Battery Pack
- Maintaining the LCD Quality

---

Preventive maintenance is limited to cleaning the plastic case, the keyboard, the display screen, and the diskette drive heads, as required.

---

 **Note:** Remove the battery and disconnect the AC adapter before performing any maintenance. Voltage is present inside the system unit and LCD even after the system is turned off.

---

## ***Cleaning the Notebook Exterior***

Use the steps below to clean the outer surface of the system.

1. Power off the system and remove all battery packs. Unplug all cables connected to the system.
2. Wipe the outside of the system, keyboard, and display with a soft, clean cloth. Remove stains with a damp, almost dry cloth. Use glass cleaner to clean the LCD. Apply the glass cleaner directly to the cloth and then wipe the LCD. Do not use solvents or strong, abrasive cleaners on any part of the system.
3. Clean the keys with a damp cloth. A small, soft-bristle brush may be used to clean between the keys. Make sure to use a damp cloth (not wet) to prevent moisture from seeping between the keyboard and the metal plate, possibly damaging the components under the keys. If the keyboard gets wet, thoroughly dry it before reassembling the system unit.

## ***Cleaning the Notebook Interior***

When servicing the inside of the notebook, remove dust and other foreign particles from inside the system unit as follows:

1. Remove the top cover and keyboard using the disassembly procedures discussed in the section, Disassembly and Reassembly, in Chapter 3.
2. Dust or vacuum (with a rubber-tipped nozzle) the inside of the system, particularly the motherboard surface. Use care to avoid damaging or dislodging any components or cables.
3. Inspect all cables connectors for damage. Ensure that connectors are seated properly before replacing the cover.

## ***Protecting the Disk Drives***

To protect the disk drives and data, back up the system disk periodically on diskettes. Periodically use a head-cleaning diskette in the disk drive to prolong the life of the drive and to help maintain data integrity.

Here are some maintenance procedures to use when servicing a hard disk:

- Always back up the data files from the hard disk.

- 
- Run a virus detecting program to check for possible virus infected areas on the hard disk.
  - Use the preinstalled ScanDisk program to correct any errors found in the directory and File Allocation Table (FAT). This also frees up space from any unused sectors.
  - Never turn the computer off when the hard disk is being accessed.
  - Never move or raise the computer while the hard disk is being accessed. Be especially careful not to jar the hard disk during access, this can cause a hard disk crash.
  - Use hard disk maintenance program like DEFRAG under DOS, or acquire Norton Utilities SPEEDISK programs. These programs reorganize your hard disk by eliminating fragmentation and improve the hard disk access time.

## ***Handling the Battery Pack***

The battery pack furnished with the computer requires reasonable care and handling to ensure efficient operation and maximum life. Periodically inspect the battery terminals and the batteries for evidence of corrosion and oxide build-up.

To ensure that the battery pack endures for a normal life cycle, always observe the following precautions when handling the battery packs:

- Do not drop the battery packs or subject them to excessive shock and vibration.
- Do not expose the battery packs to direct sunlight, moisture, chemical compounds, or extreme heat.
- Do not disassemble the battery packs.
- Do not use the battery packs to power other devices.
- Do not short the battery leads or connect the battery with reversed polarity.
- Never attempt to charge the battery packs in any way other than as described in this manual and the user's guide.
- Always charge the battery packs as soon as possible after a low battery indication.

---

## ***Maintaining the LCD Quality***

When it comes to screen problems, heat plays a big part. After a good working session, the typical routine is to shut the machine and close the cover. The display surface (no matter what type it is) radiates heat. When you close the cover, you trap the heat against the screen. Make sure to leave the computer's cover open for about ten minutes while the heat disperses, before closing the LCD.

# 7

## Troubleshooting

- Quick Troubleshooting
- Helpful Questions

---

# Quick Troubleshooting

This section summarizes problems that may develop during system operation and lists suggested corrective actions.

## Quick Troubleshooting

Problem	Corrective Action
No power	<p>Check that the AC adapter is plugged into the power connector of the system. Also, check that the AC adapter is plugged into a properly grounded AC power outlet.</p> <p>If using the battery as the main power source, check if the battery pack is the right type, is charged, and is inserted correctly.</p> <p>Check the main board of the system. Is it inserted into the CPU board connector properly? Otherwise, replace the main board.</p>
Data on the LCD is unreadable	<p>Check LCD Panel View Expansion in BIOS, Press <b>Fn-F10</b> to toggle Panel View Expansion for DOS mode.</p> <p>Check if installed VGA driver is correct.</p> <p>Check the VGA controller chip on the main board for any loose soldering.</p> <p>Replace the main board.</p>
Battery power does not last long	<p>Make sure that the power management features are enabled.</p> <p>Recharge the battery pack for 2 hours or up to 100% before using again.</p> <p>Replace the battery pack.</p>
System halts during boot sequence	<p>Check condition of selected boot device (diskette, hard disk or CD-ROM) for bad boot track or incorrect O/S files.</p> <p>Try booting from a new bootable diskette and recopy or repartition hard disk.</p> <p>Check for any BIOS error messages on the display screen.</p> <p>Replace the CPU board or main board.</p>
I/O processing malfunctions	<p>Check the connections of all internal devices.</p> <p>Replace the CPU board or main board.</p>
Diskette or SuperDisk does not work	<p>Check diskette type is correct or not faulty.</p> <p>Replace the diskette drive.</p> <p>Replace the main board.</p>

---

---

## **Quick Troubleshooting**

<b>Problem</b>	<b>Corrective Action</b>
Hard disk drive malfunction	<p>Check if hard disk drive is set properly on CMOS Setup.</p> <p>Check the drive connections.</p> <p>Check if the disk drive is good.</p> <p>Replace the CPU board or main board.</p>
Memory malfunction	<p>Check if the memory module is inserted properly.</p> <p>Replace the memory module.</p> <p>Replace the CPU board.</p>
External keyboard or PS/2 mouse does not work	<p>Check if keyboard or mouse is connected properly. Check Y adapter if it is being used. Power off system first before plugging in the device.</p> <p>Replace the keyboard or mouse.</p> <p>Replace the CPU board or main board.</p>
Serial device does not work	<p>Check if device driver is installed properly.</p> <p>Check if serial device is connected properly.</p> <p>Check the device drive installation for any IRQ or I/O address conflict.</p> <p>Replace serial device.</p> <p>Check the I/O controller chip on the main board for any cold or loose soldering.</p> <p>Replace the I/O board.</p>
PC card does not work	<p>Check the PC card driver installation for any IRQ or I/O address conflict.</p> <p>Check if the PC card is inserted properly and all connections are set.</p> <p>If the PC card is a Type II card, install it in the system's other PC card slot.</p> <p>Replace the PC card.</p> <p>Replace the main board.</p>
NEC VersaGlide does not work	<p>Check if PS/2 or Alps mouse driver is properly installed.</p> <p>Check VersaGlide cable inside the system if it is inserted properly.</p> <p>Clean VersaGlide surface.</p> <p>Check the keyboard controller chip for any cold or loose soldering.</p> <p>Replace the main board.</p>

---



---

### **Quick Troubleshooting**

<b>Problem</b>	<b>Corrective Action</b>
Parallel device does not work	Check all connections.  Check if external device is turned on.  Check the device drive installation for any IRQ or I/O address conflict.  Test another parallel device.  Check I/O controller chip on the main board for any cold or loosed soldering.  Replace the main board.

---

## **Helpful Questions**

Here are some helpful questions to ask when troubleshooting the notebook:

- Is there any external power source connected to the computer?
- Is the battery fully charged?
- Is the computer turned on and the Power LED activated?
- Is the LCD display switched to the external monitor?
- Are all cables and devices connected properly and securely?
- Are all needed device drivers installed properly?
- Have you checked the AUTOEXEC.BAT and CONFIG.SYS files for errors?
- Is the Suspend Mode activated? Press any key or press the Power switch to power on the system.

# 8

## Getting Services and Support

- Services and Support Contact Information
- NEC CSD Web
- NEC CSD FTP Sites
- Email/Fax to Support Services
- NEC CSD Bulletin Board
- NEC CSD Support Services
- NEC CSD Customer Assistance Center

---

# Services and Support Contact Information

## NEC CSD Services and Support

Service	Contact Information
NEC CSD Web and FTP Sites	Web address: <a href="http://www.nec-computers.com">www.nec-computers.com</a>  FTP site: <a href="ftp://ftp.neccsdeast.com">ftp.neccsdeast.com</a>
Email to NEC CSD Support Services through a commercial online service or the Internet.	Internet email address: <a href="mailto:tech-support@neccsd.com">tech-support@neccsd.com</a>
Fax Service to NEC CSD Support Services	801-981-3133
NEC CSD Bulletin Board System	916-379-4499
NEC CSD Support Services	U.S. and Canada: 800-632-4525 International: 801-578-5103
NEC CSD Customer Assistance Center	888-632-9128

---

---

 **Note:** If you purchased your computer outside of the U.S. or Canada, please contact the local NEC office or their dealers for support and service.

See the booklet, "Getting Service and Support in Asia, Australia, and Europe" to find out how to contact the local office in your country.

---

If you have access to a telephone, modem, and/or fax machine, you can use these services to obtain information about your system at any time, day or night, seven days a week.

Not only do these services provide information about your NEC system, they can also be used to answer your questions and help solve any problems you may have with your system, should that ever be necessary.

## NEC CSD Web Site

If you have a modem or a network board, you can access the NEC CSD web site. You can do this through a commercial online service or through your Internet account. The NEC CSD web site contains general information about NEC CSD and its products, an online store, press releases, reviews, and service and support information.

Look in the Service and Support area for the following:

- technical documentation, including Frequently Asked Questions, reference manuals, and warranty information
- BIOS updates, drivers, and Setup Disk files to download

- 
- contact information, including telephone numbers for Technical Support and links to vendor Web sites
  - Click, the NEC CSD Customer Service newsletter
  - an automated email form for your technical support questions
  - a Reseller's area (password accessible).

To access NEC CSD's Home Page, enter the following Internet Uniform Resource Locator (URL) in your browser:

**<http://www.nec-computers.com/>**

## ***NEC CSD FTP Site***

You can use the Internet to access the NEC CSD FTP (file transfer protocol) site to download various files (video drivers, printer drivers, BIOS updates, and Setup Disk files). The files are essentially the same files as on the NEC CSD Web site and the NEC CSD Bulletin Board System.

To access the NEC CSD FTP site, enter the following Internet ftp address through your service:

**<ftp.neccsdeast.com/>**

Once in the file menu, follow the prompts to choose and download the file(s) you want.

## ***Email/Fax to Support Services***

The NEC CSD Support Services offers technical support by email over the Internet network if you have a modem. The Internet address is:

**[tech-support@neccsd.com](mailto:tech-support@neccsd.com)**

You can also fax technical questions to the NEC CSD Support Services if you have access to a fax machine or fax/modem. The fax number is:

**(801)-981-3133**

When using the email or fax support service, you should include the following words in the subject field for prompt response from the appropriate technical person:

- Desktop
- Monitor
- Notebook.

---

You should provide as much specific information about your questions as possible. Also, if you are sending a fax, please include your voice telephone number and your fax number with the question. You will receive a response to your questions within one business day.

## ***NEC CSD Bulletin Board***

If you have access to a modem, you can use the NEC CSD Bulletin Board System (BBS) to get the latest information on hardware and software. The BBS allows you to download files (video drivers, printer drivers, BIOS updates, etc.) to a diskette for system enhancements and upgrades.

Log onto the BBS as follows.

1. From the Windows desktop, click the Start button.
2. Point to Programs. Point to Accessories and then click HyperTerminal.
3. Double click the Hypertrm icon. The HyperTerminal program appears.
4. Follow the instructions on the screen to set up your modem. Click the HyperTerminal help button for information about dialing the phone number.

If you need to check communications settings, check that the settings match the following BBS parameters.

- Baud rate: select any baud rate that matches your modem
  - Parity: none
  - Data bits: 8
  - Stop bits: 1
  - Flow control: Xon/Xoff (select Hardware if using 14.4 bps or higher).
5. Following the HyperTerminal instructions, enter the BBS phone number (916-379-4499). Your business phone system and/or location might require a **9 1** or **1** prefix.

---

 **Note:** The first time that you use the BBS, you are requested to provide information for a new user questionnaire.

---

6. Press **Enter** twice.
7. Enter your first name, last name, and password. Press **Enter** after each.
8. Follow the screen prompts until the Main menu appears.
9. At the Main menu, select **J** to join a conference. Select **Conference 2** for the laptop and portable PC conference.
10. From the Main menu, press **F** for the File menu.

- 
- 11.** Press **L** twice to list the file areas (47 for BIOS, 48 for drivers, and 49 for video drivers. Press **Enter** to list the available files. Follow the prompts to select a file for downloading.



## **CAUTION**

Executable files automatically format your diskette when you download files from the BBS. Formatting destroys any data on the diskette. Before you download files from the BBS, check that you do not have information on the diskette that you need.

---

After you complete downloading your file, log off the BBS as follows:

1. Press **Enter** (to continue).
2. Press **G** (command for Goodbye/Hangup).
3. Press **Enter**.

## ***NEC CSD Support Services***

NEC CSD also offers direct technical support through Support Services. (NEC CSD Support Services is for U.S. and Canadian customers only; international customers should contact the local NEC office or dealer for the support and service available in your country.)

Direct assistance is available 24 hours a day, 7 days a week. Call the NEC CSD Support Services, toll free, at **1-800-632-4525** (U.S. and Canada only) for the following support.

- System hardware — toll-free phone support is limited to the length of the standard warranty.

For hardware support after the standard warranty, get system hardware support for a fee.

- Preinstalled software — toll-free phone support for 90 days from the time of your first call to the NEC CSD Support Services.

After the initial 90 days, get preinstalled software for a fee.

Please have available your system's name, model number, serial number, and as much information as possible about your system's problem before calling.

For outside the U.S. or Canada, please contact your local NEC office or dealer for the support and service available in your country.

---

## ***NEC CSD Customer Assistance Center***

NEC CSD offers Customer Service for extended warranty and contract information, spare parts ordering, warranty claims, repair services, and service authorizations.

Direct assistance is available Monday through Friday from 8:30a.m. to 8:00p.m. EST. Call the NEC CSD Customer Assistance Center, toll free, at **1-888-632-9128** (U.S. and Canada only).

# 9

## Specifications

- System Components
- Pin Assignments
- Connector Locations
- Memory Map
- Interrupt Controllers



---

# System Components

The following system component specifications are standard except where noted.

## System Processor

Intel Pentium MMX — 200-MHz, 233-MHz  
Intel Pentium II — 233-MHz, 266-MHz, 300-MHz  
Intel Pentium II — 300PE, 333-MHz, 366-MHz; 400-MHz, all with AGP

## Architecture

64-bit Peripheral Component Interconnect (PCI)

## Random Access Memory

- Standard Main Memory — 32- or 64-MB SDRAM SO-DIMM
- Optional Expansion — 1 slot
  - Expandable in 32-MB, 64-MB, or 128-MB increments
  - Maximum 192 MB (Pentium MMX) or 256 MB (Pentium II)
- Video RAM — 4 MB SVRAM (non-AGP) or 8 MB SDRAM (AGP)
- L2 Cache RAM — 512-KB (non-AGP) or 256-KB (AGP)

## Read-Only Memory

256 KB x 8 bit, Flash ROM (non-AGP)  
512 KB x 8 bit, Flash ROM (AGP)

## Calendar Clock

Year/month/day/hour/minute/second maintained by internal back-up battery

## Input/Output (I/O) Facilities

Integrated industry-standard interfaces

- Parallel — 1 port, 25-pin D-sub (ECP and EPP support)
- Serial — 1 port, 9-pin D-sub
- Infrared — 1 port, IrDA-1 compatible
- VGA — 1 port, 15-pin high-density D-sub
- External Keyboard/External Mouse — 1 port, PS/2, 6-pin MiniDIN; exclusionary use or both supported with optional Y-cable adapter
- Expansion — 1 port, 240-pin for optional NEC Versa Dock or optional NEC Versa PortBar
- Microphone — 1 port, 3-pin, Mini Pin Jack

- 
- Stereo Headphones/Line-out — 1 port, 3-pin, Mini Pin Jack, .5 watts per channel
  - Stereo Line-In — 1 port, 3-pin, Mini Pin Jack
  - TV Out
    - 1 port; 2-pin RCA Jack
    - 1 port, 7-pin S-Video Jack
  - DC In — 1 port, for AC adapter cable
  - USB port — 1 port, 6 pin

### Speakers

Two built-in, 1.4 watts (W) each with a maximum 3W output

- 16-bit stereo, 48 KHz
- Sound BlasterPRO compatible
- MIDI Roland: MPU401, UART Mode compatible
- ESS Maestro2E (PCI Audio) + ESS 1918 (non-AGP) or ESS 1920 (AGP) (AC97 Link)

### PC Card Slots

- Two 32-bit card slots for two Type II PC cards or one Type III PC card, 5 V or 3.3 V interface
- 32-bit CardBus support

### LCD Panel

The LCD panel varies, depending on the model.

- 12.1-inch high resolution active matrix Thin Film Transistor (TFT), Super Video Graphics Array (SVGA) color display
  - Resolution — 800 x 600
  - Colors — 16.8 Million, max
- 13.3-inch high resolution active matrix Thin Film Transistor (TFT), Extended Graphics Array (XGA) color display
  - Resolution — 1024 x 768
  - Colors — 16.8 Million, max
- 14.1-inch high resolution active matrix Thin Film Transistor (TFT), Extended Graphics Array (XGA) color display
  - Resolution — 1024 x 768
  - Colors — 16.8 Million, max

---

## Keyboard

Membrane 85 keys (both U.S. and International) with standard QWERTY-key layout (International keyboards are country-specific)

- Function keys — 12 keys
- Cursor Control keys — 4 keys; arrow keys arranged in inverted T layout
- Numeric keypad — embedded
- Fn key — function key for ROM-based key functions
- Stroke — 3 mm

## Diskette Drive

- Size — 3.5-inch
- Capacity — 1.44 MB (formatted), 2 MB (unformatted)
- Transfer Rate — 250 to 500 K/bps
- Interleave 1:1
- Controller — NS PC87338VJG (non-AGP) or NS PC97338VJG (AGP)

## SuperDisk™ Drive

- Formatted Capacity:
  - Optical diskette — 120 MB
  - High Density floppy diskette — 1.44 MB
  - Double Density floppy diskette — 720 KB
- Data Transfer Rate
  - 120-MB: 680 KB/S (max)
  - 1.44-MB: 150 KB/S (max)
  - 720-KB: 75 KB/S (max)
- Track to track seek rate
  - 120-MB: 20ms (typ)
  - 1.44-MB/720-KB: 25ms (typ)

---

## Hard Disk Drive

Specifications vary depending upon model:

- Ultra DMA/33 support
- Capacity — Internal 2.1 GB, 3.2 GB, 4.0 GB, 5.1 GB, 6.0 GB, or 10 GB
- 9.5 mm, 12.5 mm, or 12.7 mm
- Read/write track-to-track seek rate — 3 ms - 4.5 ms
- Average seek time — 12 ms - 14 ms
- Revolutions per minute — 4000 - 4200
- Data transfer rate
  - 16.6 MB/sec (PIO mode4/DMA mode2)
  - 33.3 MB/sec (ultra DMA)
- Media data rates — 82.4 bit/sec - 118.0 bit/sec
- Mean Time Between Errors (MTBF) — 300,000 hours

## 24X-speed CD-ROM Drive

- Type — 5-inch CD-ROM Pack
- Average Data Transfer Rates
  - 2550 KB/second (mode 1)
  - 2907 KB/ second (mode2)
- Read Rate — 3600 KB/sec max, 2550 KB/sec avg
- Burst Transfer Rate — 16.7 MB/sec, PIO mode4/DMA mode
- Average Access Time
  - 120 ms (Random)
  - 250 ms (Fullstroke)
- Memory Buffer — 128 KB
- Interface — IDE (ATAPI)
- Photo CD Compatibility — Multisession Photo CD, Video CD (CD-1, CD-I Ready, CD-G, CD-Plus, CD-DA, CD-EXTRN, and CD-ROM XA)

---

## Power

### AC Adapter

- Input Voltage — 100 to 240 volts (V) AC, 50 or 60 Hz, 1.5 A
- Output Voltage — 15.0 V DC, 60 Watt
- Australia, Europe and Asia use an AC power cable specific to each country's standards.

### Battery Pack

- Type — twelve-cell Lithium Ion (Li-Ion)
- Output Voltage — 10.8 V
- Capacity — 4,800 mAH
- Battery Life — Approximately 2-4 hours, under typical operating conditions.
- Recharging Time — Approximately 2.7 hours when the system is on or off.

### Bridge Battery

When fully charged, backs up memory contents and system status for up to 5 minutes under Suspend mode.

## Dimensions

### System

- Width — 12.1 in. (309 mm)
- Depth — 10.0 in. (254 mm)
- Height — 1.85 in. (47 mm)

### Battery Pack

- Width — 4.47 in. (114 mm)
- Depth — 6.19 in. (158 mm)
- Height — 0.72 in. (18.5mm)

## Weight

- NEC Versa
  - 5.65 lb (2.57 kg) to 5.83 lb (2.65 kg) without primary battery or VersaBay III device installed
  - 7.7 lb (3.4 kg) to 7.9 lb (3.59 kg)
- Battery Pack — 1.12 lb (.51 kg)

---

## Recommended Environment

### Operation

- Temperature — 41°F to 95°F (5°C to 35°C)
- Relative Humidity — 20% to 80% (Noncondensing)

### Storage

- Temperature — -4°F to 104°F (-20°C to 40°C)
- Relative Humidity — 20% to 80% (Noncondensing)

## Pin Assignments

### *Keyboard/Mouse Connectors*

Pin	Signal
1	Keyboard Data
2	Mouse Data
3	Ground
4	+5V
5	Keyboard Clock
6	Mouse Clock

### *Serial Port Connector Pin Assignments*

Pin	Signal
1	Data Carrier
2	Receive Data
3	Transmit Data
4	Data Terminal Ready
5	Ground
6	Data Set Ready
7	Request to Send
8	Clear to Send
9	Ring Indicator

---

### ***Power Connector***

<b>Pin</b>	<b>Signal</b>
1	ADP IN
2	Ground
3	Ground*

\* Connect to pin 2 when using the AC adapter.

---

### ***Parallel Printer Pin Assignments***

<b>Pin</b>	<b>Signal</b>
1	Strobe
2	Data Bit 0
3	Data Bit 1
4	Data Bit 2
5	Data Bit
6	Data Bit 4
7	Data Bit 5
8	Data Bit 6
9	Data Bit 7
10	Acknowledge
11	Busy
12	PE
13	Select
14	Auto Feed XT
15	Error
16	Initialize
17	Select In
18 -25	Ground

---

---

### **Hard Disk Drive Connector**

<b>Pin</b>	<b>Signal</b>
1	Not Used
2	Not Used
3	Not Used
4	Not Used
5	+5V
6	+5V
7	Not Used
8	Ground
9	+5V
10	+5V
11	Ground
12	HDD Access LED
13	Chip Select 0
14	Chip Select 1
15	Address 2
16	Address 0
17	Diagnostic
18	Address 1
19	Not Used
20	IRQ
21	Ground
22	DMA Acknowledge
23	Ground
24	I/O Channel Ready
25	Ground
26	I/O Read
27	Ground
28	I/O Write
29	Ground
30	DMA Request
31	Not Used
32	Ground
33	Data15
34	Data0

---



---

### ***Hard Disk Drive Connector***

<b>Pin</b>	<b>Signal</b>
35	Data14
36	Data1
37	Data13
38	Data2
39	Data12
40	Data3
41	Data11
42	Data4
43	Data10
44	Data5
45	Data9
46	Data6
47	Data8
48	Data7
49	Ground
50	RESET

---

---

### ***CRT Connector Pin Assignments***

<b>Pin</b>	<b>Signal</b>
1	Red
2	Green
3	Blue
4	OPT1
5	Ground
6	Ground
7	Ground
8	Ground
9	+5V PnP VESA Vcc
10	Ground
11	OPT2
12	PnP VESA Data
13	Horizontal Sync
14	Vertical Sync
15	PnP VESA Clock

---

---

# Connector Locations

## Connector Locations

Connector	Location
P1	Main Board
P2	Main Board
P4	Main Board
P5	Main Board
P10	Main Board
P11	Main Board
P12	Main Board
P13	Main Board
P14	Main Board
P23	Main Board
P24	Main Board
P28	Main Board
P29	Main Board
P31	Audio Board
CP7	Connector Board
CP8	Connector Board
CP9	Connector Board
CP10	Connector Board
CP11	LED Status Board
CP12	LED Status Board
CP13	LED Status Board
CP14	VersaGlide
CP15	VersaGlide
CP16	VersaGlide
CP17	LCD Panel Switch Board

---

---

# Memory Map

The system supports system and video shadowing, both controlled through complementary metal oxide semiconductor (CMOS). The system supports BIOS as a cacheable area with write protection. The following table shows the system's memory map.

**System Memory Map**

---

Memory Space	Size	Function
000000-0002FFh	768 bytes	BIOS Interrupt Vector Table
000300-0003FFh	256 bytes	BIOS Stack Area
000400-0004FFh	256 bytes	BIOS Data Area
000500-09FFFFh	639 KB	Applications Memory (used by the O/S, device drivers, TSRs, and all DOS applications)
0A0000-0AFFFFh	64 KB	Video Buffer (EGA and VGA)
0B0000-0B7FFFh	32 KB	Video Buffer (monochrome, CGA color, VGA monochrome)
0B8000-0BFFFFh	32 KB	Video Buffer (CGA, EGA color, and VGA color)
0C0000-0CBFFFh	64 KB	Video ROM (EGA and VGA)
0D0000-0DFFFFh	64 KB	Used by Adapter ROMs (i.e., network controllers, hard disk controllers, SCSI host adapters)
0E0000-0EFFFFh	64 KB	Used by System ROM adapters (i.e., network controllers with boot capability)
0F0000h-0FFFFFh	64 KB	System AMIBIOS (includes Setup and hard disk drive utilities)
100000h-1FFFFFF (non-AGP)	32 MB (non-AGP)	Built-In Extended Memory
100000h-3FFFFFF (AGP)	64 MB (AGP)	
2000000-5FFFFFF (non-AGP)	up to 256 MB (both)	Extended Memory
4000000-FFFFFF (AGP)		

---

---

# Interrupt Controllers

Using interrupts, hardware can request software services. If non-Plug and Play software is being used, the interrupt may need to be moved for software application or driver compatibility. Some interrupts cannot be moved. Fifteen interrupts can be used with a cascade connection of 8259INTC x 2. The table shows default interrupt level assignments 0 through 15, in order of decreasing priority.

## ***System Interrupt Controllers***

<b>Controller Master/Slave</b>	<b>Priority</b>	<b>Name</b>	<b>Device</b>
Master	0	IRQ00	System Timer 1
Master	1	IRQ01	Keyboard
Master	2	IRQ02	Programmable Controller
Slave	3	IRQ08	Real-time Clock
Slave	4	IRQ09	USB Port
Slave	5	IRQ10	PC Card Bus Controller/Video (AGP)
Slave	6	IRQ11	VersaBay in Versa Dock
Slave	7	IRQ12	PS/2 Mouse/NEC VersaGlide
Slave	8	IRQ13	Math Coprocessor (built into CPU)
Slave	9	IRQ14	Hard Disk Controller 1
Slave	10	IRQ15	VersaBay III
Master	11	IRQ03	Infrared Port, when enabled
Master	12	IRQ04	Serial Port
Master	13	IRQ05	Sound/PC CardBus Controller (AGP)
Master	14	IRQ06	Diskette Drive Controller
Master	15	IRQ07	Parallel Port

---

# Glossary

## A

### **applications programs**

Software designed to perform specific functions, like solving business or mathematical problems.

### **AC Adapter**

A device that connects an NEC Versa portable computer and an AC wall outlet to provide AC power for running the system or recharging the battery.

### **AGP**

Advanced Graphics Port is an interface specification designed for the throughput demands of 3D graphics. AGP introduces a point-to-point channel allowing the graphics controller direct access to main memory, increases bandwidth to 266-MBps, and supports throughputs of 533-MBps and 1.07-GBps.

## B

### **base RAM**

Area of system memory between 0 and 640 kilobytes available to the user for operating system and application programs.

### **BIOS**

Basic Input Output System. A collection of primitive computer routines, usually burnt into ROM, that controls the real-time clock, keyboard, disk drives, video display, and other peripheral devices.

### **bit**

Binary digit. The smallest unit of computer data.

### **bits per second**

(bps) A unit of transmission. Also called baud rate.

### **board**

Printed circuit board. Board onto which computer components are soldered and thin wires are printed to connect the components.

### **boot**

To start up a computer. See cold boot and warm boot.

### **bus**

An electronic circuit within a computer used for transmitting data or electrical power from one device to another.

### **byte**

Group of eight contiguous bits.

---

## C

### **clock**

Electronic timer used to synchronize computer operations.

### **CMOS**

Complementary Metal Oxide Semiconductor. A chip that contains nonvolatile memory in the NEC Versa. CMOS is backed up by an internal lithium battery that preserves clock/calendar data and system configuration parameters stored in CMOS.

### **cold boot**

Process of starting up the computer by turning on the power. If power is already on, the process means to turn off the computer and turn it on again. A cold boot reinitializes all devices.

### **crt**

Cathode-Ray Tube. A type of display screen used in desktop monitors. It forms the screen image using tiny dots called pixels. See also LCD.

### **cursor**

A movable image on the display screen that indicates where the next entered data appears.

## D

### **diskette**

A thin flexible platter coated with a magnetic material for storing information.

### **diskette drive**

A magnetic drive that writes on and retrieves data from a diskette.

### **DSTN**

Double-Scan Super-Twisted Nematic. A type of technology used in some NEC Versa LCD screen displays.

## E

### **enhanced VGA**

A video interface that offers more colors or higher resolution than VGA.

### **extended RAM**

The area of RAM above the first megabyte of memory in the system available for enhancing system performance.

---

## F

### **function key**

The set of keys on the keyboard (usually F1 through F12) that let you get help and error message information or quickly select frequently used commands.

## H

### **hard disk**

A rigid magnetic storage device that provides fast access to stored data.

### **hardware**

The electrical and mechanical parts from which a computer is made.

### **hertz**

(Hz) A unit of frequency equal to one cycle per second.

### **hot key**

Combination of two or three keys (such as **Ctrl-Alt-Del**) that you press simultaneously for a particular function.

## I

### **input/output**

(I/O) The process of transferring data between the computer and external devices.

### **IDE**

Intelligent Drive Electronics. A hard disk drive type that has controller electronics built into the drive and delivers high throughput.

### **interface**

A connection that enables two devices to communicate.

### **interrupt**

A special control signal from an I/O device that diverts the attention of the microprocessor from the program to a special address.

## K

### **kilobyte**

(KB) 1024 bytes.

## L

### **LAN**

Local Area Network.



---

## **LCD**

Liquid Crystal Display. An LCD consists of a thin sandwich of two glass plates with sealed edges, containing nematic liquid-crystal material that forms the screen image. The NEC Versa displays are LCD type.

## **load**

To copy a program into the computer's memory from a storage device.

## **M**

### **megabyte**

(MB) 1,048,576 bytes.

### **memory**

Electronic storage area in a computer that retains information and programs. A computer has two types of memory — read-only memory (ROM) and random access memory (RAM).

### **menu**

A video display of programs or options.

### **microprocessor**

A semiconductor central processing unit that is the principal component of a microcomputer. Usually contained on a single chip that includes an arithmetic logic unit, control logic, and control-memory unit.

### **mode**

A method of operation; for example, the NEC Versa operates in either normal or power-saving modes.

### **modem**

MODulator-DEModulator. A device that links computers over a telephone line.

## **N**

### **nonvolatile memory**

Storage media that retains its data when system power is turned off. Nonvolatile memory in the NEC Versa is a complementary metal oxide semiconductor (CMOS) chip which is backed up by an internal battery. The backup battery preserves the clock/calendar data and system configuration parameters stored in CMOS. See volatile memory.

## **O**

### **operating system**

Set of programs that manage the overall operation of the computer.

### **overwrite**

Storing information at a location where information is already stored, thus destroying the original information.

---

## P

### **page**

A type of message transmission in which a message is sent or received via modem to a paging device from a computer (with paging communications software) or telephone.

### **parallel interface**

Interface that communicates eight bits at a time.

### **parallel printer**

A printer with a parallel interface.

### **parameter**

A characteristic of a device or system.

### **password**

A string of characters that the user must enter before the system allows access or system privileges.

### **PCMCIA**

A credit card sized peripheral interface standard for portable devices. Types of PCMCIA cards currently offered by major vendors include fax/modems, LAN, storage cards, and wireless communications devices.

### **peripheral**

Input or output device not under direct computer control. A printer is a peripheral device.

### **pixels**

Picture elements. Tiny dots that make up a screen image.

### **port**

Provides the means for an interface between the microprocessor and external devices. A cable connector is usually plugged into the port to attach the device to the computer.

### **processor**

In a computer, a functional unit that interprets and executes instructions.

### **prompt**

A special symbol indicating the beginning of an input line. Also a message that appears on the screen indicating that the user must take a certain action.

## Q

### **QWERTY**

The QWERTY keyboard, designed in the 1800s for mechanical typewriters, refers to the first six keys (QWERTY) on the top row of letters on the standard keyboard.

---

## R

### **RAM**

Random Access Memory. A storage device into which data is entered and from which data is retrieved in a nonsequential manner.

### **read**

To extract data from a storage device such as a diskette.

### **ROM**

Read-Only Memory. Memory in which stored data cannot be modified by the user except under special conditions.

### **reset**

The process of returning a device to zero or to an initial or arbitrarily selected condition.

### **resolution**

The degree of screen image clarity. Video display resolution is determined by the number of pixels on the screen. Resolution is usually specified in pixels by scan lines, for example, 640 by 480. See pixels.

### **RS-232C**

Standard interface for serial devices.

## S

### **scanner**

An optical device that reads printed material and converts it to a computer screen image.

### **serial interface**

An interface that communicates information one bit at a time.

### **serial printer**

A printer with a serial interface.

### **software**

Programs that run on a computer, such as operating systems, word processors, and spreadsheets.

### **super video graphics array (SVGA)**

A color bit-mapped graphics display standard, that provides a resolution of 1024x 768 with up to 256 colors displayed simultaneously.

### **system board**

The main printed circuit board inside the system unit into which other boards and major chip components, such as the system microprocessor, are connected.

---

## T

### TFT

Thin Film Transistor. A type of NEC Versa LCD color screen that supports 256 colors and provides exceptional screen display.

## V

### VersaGlide

A small, touch-sensitive pad used as a pointing device on your NEC Versa notebook computer. With the VersaGlide, you can move your finger along the pad to move the cursor or simulate a mouse click by tapping the pad.

### VGA

Video Graphics Array. Graphics technology that supports up to 256 K colors and a graphics resolution of 640 by 480 pixels.

### volatile memory

Storage media that loses its data when system power is turned off. Standard memory and memory that you add to the NEC Versa are volatile memory. See nonvolatile memory.

## W

### warm boot

Process of resetting the computer without turning off the power through keyboard input (pressing **Ctrl**, **Alt**, and **Del** keys simultaneously) or the reset button. The system returns to an initial or arbitrarily selected condition.

### write

To record or store information to a storage device.

---

# Index

## A

- AC adapter, 2-2
  - using, 2-2
- AC outlet, 2-3
- AC power cable
  - types, 2-3
- AC power port, 1-7
- Adapter kit, 2-10
- Application and Driver CD, 2-27
  - using, 2-27
- Automatic Save to File, 2-19

## B

- Backup system disk, 6-2
- Base unit, 1-5
- Battery
  - determining status, 2-6
  - handling, 2-7
  - recharging precautions, 2-10
  - removing, 1-12
  - when to change, 2-6
- Battery charging LEDs, 1-6
- Battery pack, 1-12
  - precautions, 2-9
  - using, 2-4
- Battery status, 2-4
- BBS, 8-5
- BIOS setup, 2-11
- BIOS setup utility
  - advanced CMOS setup, 2-17
  - checking system parameters, 2-14
  - looking at screens, 2-13
  - main menu, 2-12
  - other options, 2-21
  - save to file, 2-22
  - standard CMOS setup, 2-16
  - using keys, 2-13
- Boot device setup, 2-19
- Bridge battery, 1-13, 2-11
- Brightness control, 1-3

## C

- CD-ROM drive, 1-13
- Cleaning
  - internal components, 6-2
  - outer surface, 6-2
- CMOS battery, 1-13, 2-10
- Connecting the AC adapter, 2-3

- Control panel, 1-4
- Custom settings, power management, 2-18

## D

- Dimensions
  - battery pack, 9-6
  - system, 9-6
- Dip switch settings, 3-7
- Diskette drive, 1-13
- Diskette drives, 2-17
- Docking port, 1-7
- Docking Station drives, 2-17

## E

- Entering BIOS setup, 2-11
- Expansion port, 1-7

## F

- File bay, 1-10

## H

- Handling battery packs, 6-3
- Hard disk drive, 1-13
- Headphones, 1-10
- Height adjustment feet, 1-12

## I

- Internal hard disk drive, 2-17
- Internal mouse, 2-17
- Interrupt Controllers, 9-14
- IR port, 1-8, 2-20
  - enabling, 2-31
- IRQs, 9-14

## K

- Kensington Lock, 1-10
- Keyboard panel, 1-5
- Keyboard/mouse connectors, 9-7

## L

- LCD panel features, 1-3
- LCD panel view expansion, 2-17
- LCD status bar, 1-4
- Line-In, 1-10
- Lithium-Ion battery, 2-10
- Low battery power, 1-12, 2-4

## M

- Main battery, 2-10
- Maintaining LCD quality, 6-4

---

Memory Map, 9-13  
Microphone, 1-4, 1-10  
Monitor port, 1-7  
Mouse port, 1-8

## **N**

NEC CSD  
    bulletin board, 8-5  
    Customer Assistance Center, 8-7  
    email/fax, 8-5  
    FTP site, 8-3  
    support services, 8-7  
    web site, 8-2  
NEC CSD utilities, 2-25  
NEC Customize, 2-25  
NEC Versa disassembly sequence, 3-2  
NEC VersaBay, 1-7  
NEC VersaGlide, 1-5  
NTSC signal, 1-9

## **O**

Optional battery charger, 2-4

## **P**

PAL signal, 1-9  
Panel brightness, 2-19  
Parallel port, 2-20  
Parallel port pin assignments, 9-7  
Parts list (AGP models), 5-6  
Parts list (Non-AGP models), 5-3  
Password protection, 2-21  
Pentium II microprocessor, 1-2  
Peripheral Component Interconnect (PCI), 1-2  
Power button, 1-11, 2-18  
Power management, 2-21  
    custom settings, 2-18  
Power management under AC, 2-18  
Power sources, 2-2  
Power Status LED, 1-6  
Powering on, 2-4  
Power-on self test (POST), 2-11  
PS/2 Hot Swap, 2-17

## **Q**

Quick troubleshooting, 7-2

## **R**

Recharging the battery, 2-4  
Recommended operating environment, 9-7  
Remote power on, 2-19  
Replacing the battery pack, 2-7, 3-2  
Resume Signal, 2-19

## **S**

Save to file  
    feature, 2-22  
SECAM signal, 1-9  
Serial port, 1-7, 2-20  
Services and Support  
    contact information, 8-2  
Servicing the system  
    required tools, 3-2  
Setting boot devices, 2-20  
Setting system parameters, 2-14  
    peripherals, 2-20  
    power savings, 2-18  
Smart switch, 1-11  
Software applications, 2-27  
Specifications  
    calendar clock, 9-2  
    CD-ROM drive, 9-5  
    diskette drive, 9-4  
    hard disk drive, 9-5  
    input/output facilities, 9-2  
    keyboard, 9-4  
    PC card slots, 9-3  
    power, 9-6  
    Random Access Memory, 9-2  
    Read-Only Memory, 9-2  
    speakers, 9-3  
Stereo speakers, 1-5  
Suspend mode, 2-19  
Suspend warning tone, 2-19  
Switch settings, 3-7  
    changing, 3-8  
System date, 2-16  
System features  
    back, 1-7  
    bottom, 1-12  
    front, 1-3  
    left, 1-8  
    right, 1-10  
System security setup, 2-17  
System software, 2-27  
System time, 2-17

## **T**

Troubleshooting  
    helpful questions, 7-4  
TV signal types, 1-9

## **U**

Updating the BIOS, 2-22  
USB controller, 2-20  
USB port, 1-9  
Using the AC adapter, 2-2

---

Using the battery pack, 2-4

## **V**

VersaBay III

removing a device, 1-12

Video out type, 2-17

Volume control, 1-10

## **W**

Wake up, suspend alarm, 2-19

Weight

battery pack, 9-6

system, 9-6

## **Y**

Y-cable adapter, 1-8

## Battery Replacement

A lithium battery in some computers maintains system configuration information. In the event that the battery fails to maintain system configuration information, NEC CSD recommends that you replace the battery. For battery replacement information, call your NEC CSD dealer or the NEC CSD Customer Assistance Center.

---

### **WARNING**

There is a danger of explosion if the battery is incorrectly replaced. Replace only with the same or equivalent type recommended by the manufacturer. Discard used batteries according to the manufacturer's instructions.

---

---

### **AVERTISSEMENT**

Il y a danger d'explosion s'il y a remplacement incorrect de la batterie. Remplacer uniquement avec une batterie du même type ou d'un type recommandé par le constructeur. Mettre au rebut les batteries usagées conformément aux instructions du fabricant.

---

## Battery Disposal

The main battery is made of Lithium-Ion (Li-Ion) and the CMOS clock battery is made of Lithium. Your bridge battery (not the main battery) is made of nickel-metal hydride (NiMH).

Contact your local waste management officials for other information regarding the environmentally sound collection, recycling, and disposal of the batteries. For additional information on the proper collection or disposal of rechargeable batteries, please call 1-800-8-BATTERY.



(For United States Use Only)

**Federal Communications Commission  
Radio Frequency Interference Statement**

---

 **WARNING**

Changes or modifications to this unit not expressly approved by the party responsible for compliance could void the user's authority to operate the equipment.

---

---

 Note: This is a Class B Digital Device. This equipment has been tested and found to comply with the limits for a Class B digital device, pursuant to Part 15 of the FCC Rules. These limits are designed to provide reasonable protection against harmful interference in a residential installation. This equipment generates, uses and can radiate radio frequency energy and, if not installed and used in accordance with the instructions, may cause harmful interference to radio communications.

---

However, there is no guarantee that interference will not occur in a particular installation. If this equipment does cause harmful interference to radio or television reception, which can be determined by turning the equipment off and on, the user is encouraged to try to correct the interference by one or more of the following measures.

- Reorient or relocate the receiving antenna.
- Increase the separation between the equipment and receiver.
- Connect the equipment to an outlet on a circuit different from the one to which the receiver is connected.

To meet FCC standards, shielded cables and power cords are required to connect this device to a personal computer or other Class B certified device.

---

***Canadian Department of Communications Compliance Statement***

This equipment does not exceed Class B limits per radio noise emissions or digital apparatus, set out in the Radio interference Regulation of the Canadian Department of Communications.

***Avis de conformité aux normes du ministère des communications du Canada***

Cet équipement ne dépasse pas les limites de Classe B d'émission de bruits radioélectriques pour les appareils numériques, telles que prescrites par le Règlement sur le brouillage radioélectrique élebil par le ministère des Communications du Canada.

***European Community Directive Conformance Statement***

This product is in conformity with the protection requirements of EC Council Directive 89/336/EEC on the approximation of laws of the Member States relating to electro-magnetic compatibility. This product satisfied the Class B limits of EN 55022.

NEC Computer Systems Division  
Packard Bell NEC, Inc.  
1 Packard Bell Way  
Sacramento, California 95828-0903  
1-916-388-0101

# NEC

NEC Computer Systems Division  
Packard Bell NEC, Inc.

NEC Computer Systems Division  
Packard Bell NEC, Inc.  
1 Packard Bell Way  
Sacramento, CA 95828-0903

819-200064-000

3/99

