

NEC Versa Notebook Computer

NEC VERSA® FX

SERVICE AND REFERENCE MANUAL

NEC

Proprietary Notice and Liability Disclaimer

The information disclosed in this document, including all designs and related materials, is the valuable property of NEC Computer Systems Division (hereinafter "NEC CSD") and/or its licensors. NEC CSD and/or its licensors, as appropriate, reserve all patent, copyright and other proprietary rights to this document, including all design, manufacturing, reproduction, use, and sales rights thereto, except to the extent said rights are expressly granted to others.

The NEC CSD product(s) discussed in this document are warranted in accordance with the terms of the Warranty Statement accompanying each product. However, actual performance of each such product is dependent upon factors such as system configuration, customer data, and operator control. Since implementation by customers of each product may vary, the suitability of specific product configurations and applications must be determined by the customer and is not warranted by NEC CSD.

To allow for design and specification improvements, the information in this document is subject to change at any time, without notice. Reproduction of this document or portions thereof without prior written approval of NEC CSD is prohibited.

NEC is a registered trademark of NEC Corporation, used under license.

ENERGY STAR is a U.S. registered mark.

All other product, brand, or trade names used in this publication are the trademarks or registered trademarks of their respective trademark owners.

First Printing — December 1999

Copyright 1999
NEC Computer Systems Division
6000 Florin-Perkins Road
Sacramento, CA 95828-1037
All Rights Reserved

Contents

Preface	vii
Abbreviations	ix
1 System Overview	
Getting to Know the NEC Versa.....	1-2
Around the Front of the System.....	1-2
LCD Panel.....	1-2
Base Unit.....	1-3
Power Button.....	1-5
Keyboard Panel.....	1-5
Front Features.....	1-7
Around the Back of the System.....	1-8
Around the Left Side of the System.....	1-9
Around the Right Side of the System.....	1-9
Around the Bottom of the System.....	1-10
Internal Components	1-11
Battery Pack	1-11
Hard Disk Drive	1-11
CMOS Battery.....	1-11
Bridge Battery	1-11
ChipSet.....	1-12
2 System Configuration and Setup	
Power Sources for Your NEC Versa.....	2-2
Using the AC Adapter	2-2
Connecting the AC Adapter	2-3
Powering On Your System.....	2-3
Using the Main Battery Pack.....	2-4
Determining Battery Status	2-4
Low Battery Status	2-5
Returning the Battery to its Normal State	2-5
Extending Battery Life	2-5
Battery Handling	2-5
Replacing the Battery	2-5
Charging the Battery	2-8
Battery Precautions	2-8
Precautions for Recharging the Battery.....	2-8
System Batteries.....	2-9
Main Battery	2-9
CMOS Battery	2-9
Bridge Battery.....	2-9
BIOS Setup	2-9
Pausing the Screen	2-10
BIOS Setup Main Menu.....	2-10
Looking at Screens	2-11
Using Keys	2-11
Checking/Setting System Parameters.....	2-12
Resetting System Parameters	2-12
Standard CMOS Setup	2-12
Advanced CMOS Setup	2-13
System Security Setup.....	2-13
Security Protection	2-14
Power Management Setup.....	2-15
Boot Device Setup.....	2-17

Peripheral Setup.....	2-18
Other BIOS Setup Options	2-19
Updating the BIOS	2-19
Obtaining the BIOS Update.....	2-19
Preparing the BIOS Update Diskette	2-20
Enabling the BIOS Flash Switch	2-20
Performing the BIOS Update.....	2-21
NEC Utilities.....	2-22
NEC Customize Utility.....	2-22
NEC Customize Utility Screen	2-22
Using the NEC Customize Utility	2-23
HDPREPEZ Utility.....	2-23
Using the HDPREPEZ Utility.....	2-23
Application and Driver CD	2-23
Launching the Application and Driver CD with Windows 98.....	2-24
Application and Driver CD Dialog Box	2-24
Installing the Application and Driver CD Software	2-24
3 Disassembly and Reassembly	
Required Tools and Equipment	3-2
Disassembly	3-2
Battery	3-2
Memory Module and Switch Settings	3-4
Switch Settings	3-5
Keyboard	3-6
VersaGlide Assembly.....	3-7
Top Cover.....	3-9
Hard Disk Drive.....	3-10
PC Card Assembly.....	3-11
LED Status Board.....	3-12
IR/Sound Board.....	3-12
Bridge Battery	3-13
Speakers.....	3-14
Main Board, Modem Board, and CMOS Battery	3-14
Reassembly.....	3-17
4 System Board Layout	
LED Status Board	4-2
IR/Sound Board.....	4-2
Connector Board	4-2
Video/USB Board	4-3
Main Board.....	4-3
5 Illustrated Parts Breakdown	
Illustrated Parts Breakdown	5-2
Parts List.....	5-3
6 Preventive Maintenance	
Cleaning the Notebook Exterior.....	6-2
Cleaning the Notebook Interior	6-2
Protecting the Disk Drive	6-2
Handling the Battery Pack.....	6-3
Maintaining the LCD Quality.....	6-3

7 Troubleshooting	
Quick Troubleshooting	7-2
Helpful Questions	7-4
8 Getting Service and Support	
Services and Support Contact Information	8-2
NEC CSD Web Site	8-2
NEC CSD FTP Site.....	8-3
Email/Fax to Support Services.....	8-3
NEC CSD Bulletin Board	8-3
NEC CSD Support Services.....	8-4
NEC CSD Customer Assistance Center.....	8-5
9 Specifications	
System Components.....	9-2
Connector Locations	9-6
Memory Map	9-7
Interrupt Controllers.....	9-8

Glossary

Index

Preface

This service and reference manual contains the technical information necessary to set up and maintain the NEC Versa[®] FX notebook computer.

The manual also provides hardware and interface information for users who need an overview of the system design. The manual is written for NEC-trained customer engineers, system analysts, service center personnel, and dealers.

The manual is organized as follows:

Chapter 1, System Overview, provides an overview of the hardware and interface components.

Chapter 2, System Configuration and Setup, provides information on setup and how to operate the notebook.

Chapter 3, Disassembly and Reassembly, provides detailed instructions on how to disassemble the notebook.

Chapter 4, System Board Layout, shows the system boards and the board connectors.

Chapter 5, Illustrated Parts Breakdown, shows the Illustrated Parts Breakdown (IPB) and corresponding part numbers.

Chapter 6, Preventive Maintenance, lists general notebook preventive maintenance procedures.

Chapter 7, Troubleshooting, lists troubleshooting procedures as well as helpful servicing hints.

Chapter 8, Getting Service and Support, provides information as to how to contact NEC CSD for service information, technical support, and product information.

Chapter 9, Specifications, lists physical specifications, connector locations, memory map and interrupt controllers.

A **Glossary** and an **Index** are included for convenience.

Abbreviations

A	ampere	ECC	error checking and correction
AC	alternating current	ECP	enhanced capabilities port
AGP	Advanced Graphics Port	EDO	extended data output
AT	advanced technology (IBM PC)	EGA	Enhanced Graphics Adapter
BBS	Bulletin Board Service	EPP	enhanced parallel port
BCD	binary-coded decimal	EPROM	erasable and programmable ROM
BCU	BIOS Customized Utility	EVGA	Enhanced Video Graphics Array
BIOS	basic input/output system	F	Fahrenheit
bit	binary digit	FAX	facsimile transmission
BUU	BIOS Upgrade Utility	FCC	Federal Communications Commission
bpi	bits per inch	FG	frame ground
bps	bits per second	FM	frequency modulation
C	capacitance	FP	fast page
C	centigrade	FRU	field-replaceable unit
Cache	high-speed buffer storage	GB	gigabyte
CAM	constantly addressable memory	GND	ground
CAS	column address strobe	HEX	hexadecimal
CD-ROM	compact disk-ROM	Hz	hertz
CG	character generator	IC	integrated circuit
CGA	Color Graphics Adapter	ID	identification
CGB	Color Graphics Board	IDE	intelligent device electronics
CH	channel	IDTR	interrupt descriptor table register
clk	clock	in.	inch
cm	centimeter	INTA	interrupt acknowledge
CMOS	complementary metal oxide semiconductor	IPB	illustrated parts breakdown
COM	communication	IR	infrared
CONT	contrast	IRR	Interrupt Request register
CPGA	ceramic pin grid array	ISA	Industry Standard Architecture
CPU	central processing unit	ISR	In Service register
DAC	digital-to-analog converter	I/O	input/output
DACK	DMA acknowledge	IPC	integrated peripheral controller
DC	direct current	ips	inches per second
DIP	dual in-line package	IRQ	interrupt request
DLAB	Divisor Latch Address bit	K	kilo (1024)
DMA	direct memory access	k	kilo (1000)
DMAC	DMA controller	KB	kilobyte
DOS	disk operating system	kg	kilogram
DRAM	dynamic RAM	kHz	kilohertz
DVD	digital video disk		

lb	pound	S	slave
LED	light-emitting diode	SCSI	Small Computer System Interface
LCD	liquid crystal display		
LSB	least-significant bit	SDRAM	synchronous dynamic random-access memory
LSI	large-scale integration	SG	signal ground
M	mega	SIMM	single inline memory module
mA	milliamps	SPM	standard page mode
max	maximum	SRS	Sound Retrieval System
MB	megabyte	SVGA	Super Video Graphics Array
MDA	Monochrome Display Adapter	SW	switch
MFM	modified frequency modulation	TFT	thin film transistor
MHz	megahertz	TSC	Technical Support Center
mm	millimeter	TTL	transistor/transistor logic
ms	millisecond	tpi	tracks per inch
MSB	most-significant bit	USB	universal serial bus
NASC	National Authorized Service Center	V	volt
NC	not connected	Vac	volts, alternating current
NMI	Non-maskable Interrupt	Vdc	volts, direct current
ns	nanosecond	VESA	video electronics standards association
NSRC	National Service Response Center	VFC	VESA-compliant feature connector
PAL	programmable array logic	VGA	Video Graphics Array
PCB	printed circuit board	VRAM	video RAM
PCI	Peripheral Component Interconnect	W	watt
PDA	personal digital assistant	W	write
PFP	plastic flat package	XGA	Extended Graphics Array
PIO	parallel input/output		
pixel	picture element		
PLCC	plastic leaded chip carrier		
PLL	phase lock loop		
p-p	peak-to-peak		
PPI	programmable peripheral interface		
PROM	programmable ROM		
QFP	quad flat pack		
RAM	random-access memory		
RAMDAC	RAM digital-to-analog converter		
RAS	row address strobe		
RGB	red green blue		
RGBI	red green blue intensity		
ROM	read-only memory		
rpm	revolutions per minute		
R	read		
RTC	real-time clock		
R/W	read/write		

1

System Overview

- Getting to Know the NEC Versa
- Around the Front of the System
- Around the Back of the System
- Around the Left Side of the System
- Around the Right Side of the System
- Around the Bottom of the System
- Internal Components
- Chipset

Getting to Know the NEC Versa

The NEC Versa FX notebook computer offers you a portable system filled with exciting resources for home, business or travel. Standard features include an Intel® low voltage 333-MHz (not available in the U.S.) or 400-MHz Pentium® III microprocessor that works together with the latest Peripheral Component Interconnect (PCI) architecture.

In addition, your system provides a high-performance hard disk drive, an external floppy disk drive, an external CD-ROM drive, and PC card support. As a multimedia system, your NEC Versa also provides the tools needed to create and present impressive images using video clips and sound.

NEC Versa FX notebook computer



Read the following sections and take a tour around the system.

Around the Front of the System

The NEC Versa FX is compact with features on every side. First, look at the front of the NEC Versa. The following sections describe front features, beginning with the liquid crystal display (LCD) panel.

LCD Panel

Your NEC Versa FX comes with a 12.1-inch color Thin Film Transistor (TFT) SuperVideo Graphics Array (SVGA) panel that you can adjust for a comfortable viewing position. To adjust the viewing angle, gently tilt the LCD panel into position.

To adjust the LCD panel brightness press the **Fn-F8** and **Fn-F9** functions keys. For more details about using the system's function keys, see the topic later in this chapter, "Keyboard Panel."

If the LCD panel backlight turns off when you attempt to close the panel, toggle the **Fn-F3** function key or close and open the panel to turn on the backlight.

Base Unit

The base unit of your NEC Versa FX offers the following features which are described after the figure.

LCD panel and base unit

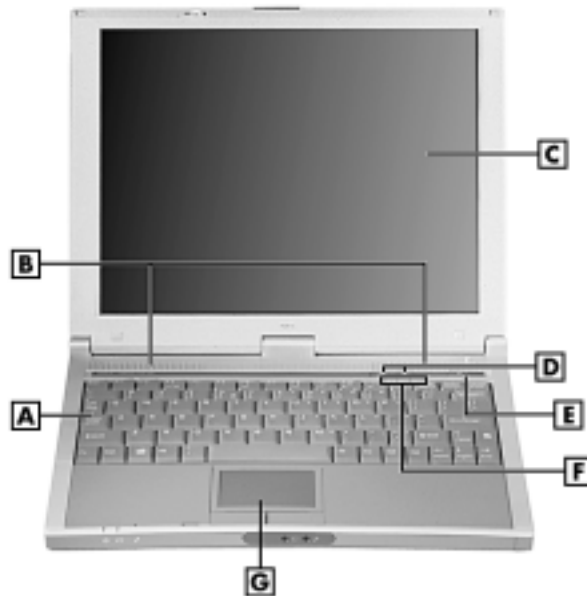

- | | |
|--------------------------------|----------------------------------|
| A – Keyboard | E – Power Button |
| B – Stereo Speakers | F – Operating Status LEDs |
| C – LCD Panel | G – NEC VersaGlide |
| D – Email/Internet keys | |

- Keyboard — 85 keys with the standard QWERTY-key layout. (Models purchased outside of the U.S. and Canada ship with country-specific keyboard layouts.)
- Stereo Speakers — Provide stereo sound for your multimedia presentations or listening pleasure. The built-in sound system also supports 3D sound, which simulates the latest surround-sound technology.
- LCD Panel — Provides a high-resolution display for sharp effective visuals on your NEC Versa.

- **Email Shortcut Key** — Launches your dial-up networking connection (if not connected to a LAN) and Outlook Express.
- **Internet Shortcut Key** — Launches your dial-up networking connection (if not connected to a LAN) and Microsoft® Internet Explorer.

Email/Internet keys

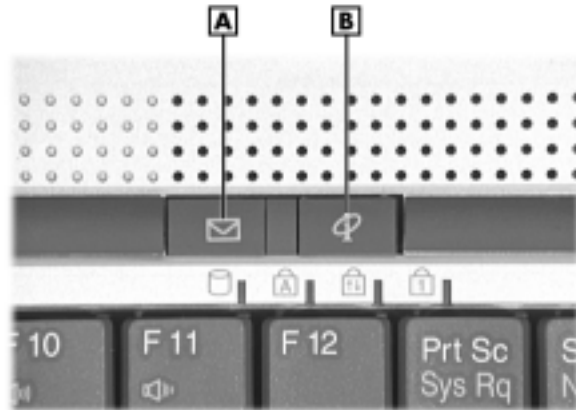

A – Email Shortcut Key

B – Internet Shortcut Key

- **Power Button** — Slide the Power button to the right to power on, power off, and to resume from Standby mode.

For more information about the Power button, see the following topic, “Power Button.”

- **Operating Status LEDs** — Keeps you informed of your NEC Versa’s current operating status. See the following figure and list for each icon’s meaning.

Operating status LEDs

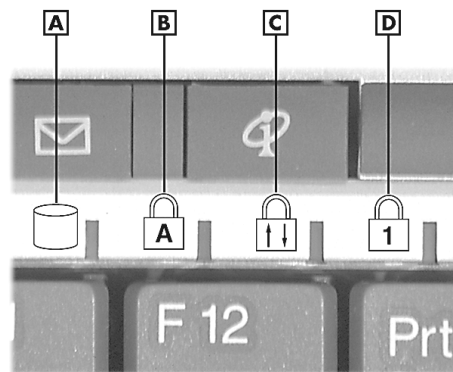

A – Hard Disk Drive

B – Caps Lock

C – Scroll Lock

D – Num Lock

— **Hard Disk Drive** — lights when the NEC Versa writes data to or retrieves data from the internal hard disk drive.

— **Caps Lock** — lights when Caps Lock is in effect.

— **Scroll Lock** — lights when Scroll Lock is in effect.

— Num Lock — lights when Num Lock mode is active.

- NEC VersaGlide — The NEC VersaGlide works like a standard computer mouse. Simply move your fingertip over the VersaGlide to control the position of the cursor. Use the selection buttons below the VersaGlide to select menu items.

Power Button

The Power/Sleep button is a “smart” switch, meaning that it recognizes when the system is in Standby mode. If in Standby mode, you cannot power off until you slide the Power button to the right to resume operation. (The BIOS parameter “System Switch” must be set to “Sleep.”)

Put the unit in Standby mode when you need to be away from your system for a short period of time and want to return to where you left off. Standby mode shuts down all devices in the system while retaining data and system status. Go to Start, Shutdown, Standby to put your system into Standby mode.

Use the Power button in the following ways:

- Slide the Power to the right to power on.
- Slide the Power button to the right to resume from Standby mode and proceed with normal operation.
- Hold the Power button in place for 4 or more seconds to power off the system (power override). Only use this option if you cannot power off your system using Start, Shutdown.

Keyboard Panel

The NEC Versa keyboard panel offers the following features, which are described after the figure.

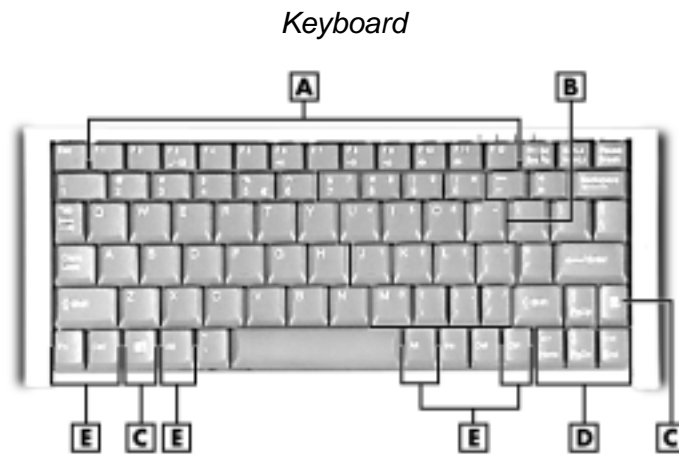

A – Function Keys
B – Numeric Keys
C – Windows keys

D – Cursor Control Keys
E – Control Keys

- Function keys — Twelve function keys, **F1** through **F12**, are available on the NEC Versa keyboard. These keys work together with the **Fn** key to activate special functions. Several keys are preprogrammed with dual functions and some are printed in blue on the key.

Function keys are application-driven. See the specific application's user guide for information about how each function key works within the application you are using.

The following function key combinations are preprogrammed for the NEC Versa FX computer.

Fn-F3 — toggles between three video modes; LCD, CRT, or both (LCD and CRT).

Fn-F4 — No function when Windows 98 is configured for Advanced Configuration Power Interface (ACPI) mode.

Fn-F5 — toggles between Standard and Full backlight.

Fn-F6 — sets the beeper speaker volume to low, medium, high, or mute.

Fn-F7 — No function when Windows 98 is configured for Advanced Configuration Power Interface (ACPI) mode.

Fn-F8 — increases the LCD panel brightness.

Fn-F9 — decreases the LCD panel brightness.

Fn-F10 — increases the system speaker volume.

Fn-F11 — decreases the system speaker volume.

Fn-ScrLck — toggles the Num lock function.

Fn-Pause — break

Fn-Left Win — right Windows key.

- Numeric keypad — Pressing NumLk on the keyboard activates the numeric keypad numbers and functions printed in blue on the keys.

The keypad lets you type numbers and mathematical operands (+, -) as you would on a calculator. The keypad is ideal for entering long lists of numbers.

When you press NumLk again, the keys revert to their normal functions as typewriter keys.

- Cursor Control keys — Cursor control keys let you position the cursor on the screen where you want. On the screen, the cursor is a blinking underline, block, or vertical line depending on the application. The cursor indicates where the next text typed is inserted.
- Windows keys — In Windows 98, use the following two keys to facilitate your work.



Quick access to shortcut menus



Display the Start menu

- Control keys — **Ctrl**, **Alt**, **Fn**, and **Shift** are controls used in conjunction with other keys to change their functions. To use control keys, press and hold the control key while pressing another key. For example, “press **Ctrl c**” means to hold down the **Ctrl** key and type the letter c. How the key combination works depends on the application you are running.
- Typewriter keys — The typewriter keys (also called alphanumeric keys) are used to enter text and characters. Keys with blue printing on them behave differently when combined with control keys or the **Fn** key.

Front Features

The front features of your NEC Versa are described after the figure.

Front features

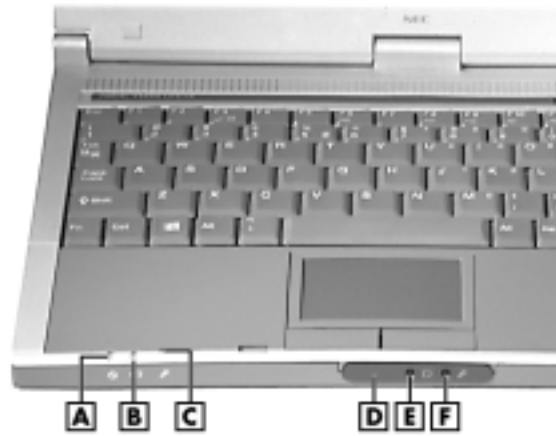

- | | |
|---------------------------------|-------------------------------------|
| A – Power Status LED | D – IR Port |
| B – Battery Charging LED | E – Headphone Jack |
| C – Microphone | F – External Microphone Jack |

- **Power Status LED** — This LED lights to indicate the following:
 - Lights green when the system power is on.
 - Blinks green when the system is in Standby mode.
 - Lights yellow (blinks when in Standby mode) to indicate that battery power is at 8% capacity or less.
 - Lights amber (blinks when in Standby mode) to indicate that battery power is at 3% capacity.
- **Battery Charging LED** — lights to indicate battery charging activity.
 - Lights amber when the primary battery is charging. Blinks amber to indicate an error. The primary battery is installed in the battery bay.
 - Lights green when the secondary battery is charging. Blinks green to indicate an error. The secondary (optional) battery is connected to the bottom of the system.
- **Microphone** — A strategically positioned built-in microphone allows you to record monophonic sound directly into your notebook computer.
- **IR Port** — Use this infrared (IR) port to transfer files between your NEC Versa and an IR-equipped desktop or notebook computer or to print to an IR-capable printer.
- **Headphone Jack** — Lets you connect external headphones or speakers to your NEC Versa. Plugging in headphones disables the built-in system speakers.
- **External Microphone (MIC)** — Allows you to connect an external microphone for monophonic recording or amplification through the unit. Plugging in an external microphone disables the built-in microphone.

Around the Back of the System

The back of your NEC Versa offers the following features, which are described after the figure.

Back features

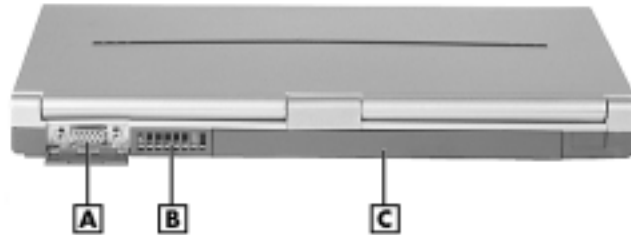

A – External Monitor Port
B – Vents

C – Battery Bay

- External Monitor (Video) Port — Use this 15-pin port to attach an external monitor to your NEC Versa. You can run the LCD display and the external monitor simultaneously or run either alone.
- Vents — Allow your system to cool properly and maintain a safe operating temperature.

 **CAUTION** Always keep the vents unobstructed to allow proper system cooling.

- Battery Bay — Contains the system's standard Lithium-Ion (Li-Ion) main battery or an optional Extra Life Li-Ion battery.

Around the Left Side of the System

The left side of your NEC Versa offers the following features, which are described after the figure.

Left side features

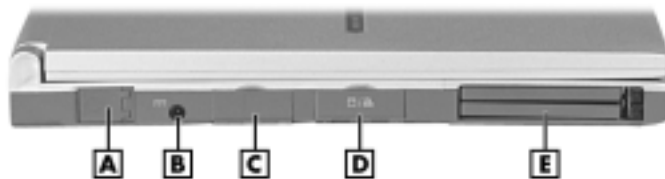

A – RJ-11 Jack
B – AC Power Port
C – LAN Cable Jack

D – Floppy Disk Drive/Parallel Port
E – PC Card Slots

- RJ-11 Jack — Use this jack to connect the internal modem to an analog wall outlet.
- AC Power Port — Use the power jack to attach the NEC Versa to a DC power source, such as the AC adapter or the optional DC auto adapter.

-
- LAN Cable Jack — Connect the optional LAN adapter cable that ships with your system (if your system is equipped with a LAN cable jack), to connect your system to a local area network (LAN). (Not available in all systems.)
 - External Floppy Disk Drive/Parallel Port — Use this port to connect the external floppy disk drive or an external parallel device using the cables that ship with your system.
 - PC card slots — Provide two slots for inserting two Type II PC cards or one Type III PC card.

Around the Right Side of the System

The right side of the NEC Versa offers the features, which are described after the figure.

Right side features

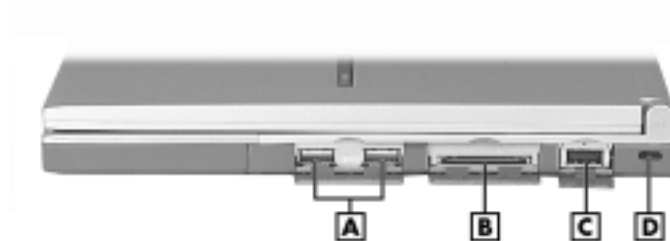

A – USB Ports
B – CD-ROM Port

C – USB Port
D – Kensington Lock

- USB Port — The Universal Serial Bus (USB) port allows you to connect up to 127 USB-equipped peripheral devices (printers, monitors, scanners, etc.) to your NEC Versa.
- CD-ROM Port — Use this port to connect the external CD-ROM drive.
- Kensington Lock — Lets you provide added security by installing an optional Kensington Lock.

Around the Bottom of the System

The bottom of the NEC Versa offers the features shown next. Features are described after the figure.

Bottom features

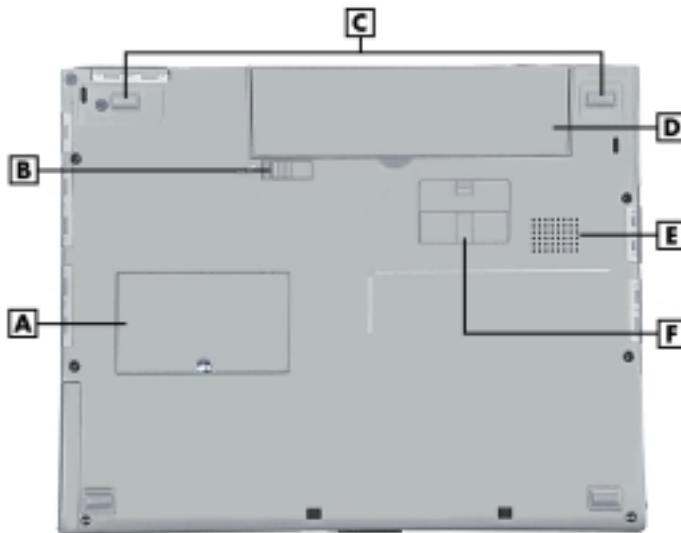

- | | |
|---------------------------|------------------------------------|
| A – Memory Module Bay | D – Main Battery |
| B – Battery Release Latch | E – Vents |
| C – System Feet | F – Maximum Life Battery Connector |

- Memory Module Bay — Stores the system's memory module.
- Battery Bay Release Latch — Allows you to release and remove the system's main battery.
- System Feet — Heightens the system to allow proper ventilation.
- Main Battery — Supplies power when the system is not connected to an AC power source.
- Vents — Allow your system to cool properly and maintain a safe operating temperature.

CAUTION Always keep the vents unobstructed to allow proper system cooling.

- Maximum Life Battery Connector — Attach the optional Maximum Life Battery to this connector.

Internal Components

Review the following sections for a description of the system's internal hardware.

Battery Pack

The system uses a rechargeable Lithium-Ion (Li-Ion) battery as its transient power source. The battery pack installs in the compartment on the bottom of the NEC Versa.

Hard Disk Drive

A standard 2.5-inch, 9.5 mm hard disk drive ships with the system.

CMOS Battery

This lithium battery (3 Volts, 30 mAH capacity) provides battery backup and prevents data loss in the system's complementary metal oxide semiconductor (CMOS) RAM. This memory area contains information on the system's configuration, for example date, time, drives, and memory. The CMOS battery charges when your NEC Versa is connected to AC power. The CMOS battery may discharge completely if the NEC Versa notebook remains unused for approximately two months..

Bridge Battery

The bridge battery saves your system status in Standby mode giving you time to install a fully charged battery or connect to AC power when your battery charge becomes low. The bridge battery stores 7.2 Volts, 40 mAH.

ChipSet

The following table provides information on the system chipset.

System Chipset

Chip	Manufacturer	Description
Intel Celeron 333 (not available in the U.S.) Intel Pentium III 400	Intel	333 MHz CPU 400 MHz CPU
82440MX	Intel	System Controller
FDC37N869	Standard Microsystems	Super I/O
SM710	Silicon Motion	Video
ESS ES1946 (Solo1E)	ESS Technology	Audio
29F004T-90EC		ROM BIOS
M38813M4	Mitsubishi	Keyboard Controller
TI1225	Texas Instruments	PCI CardBus Controller

2

System Configuration and Setup

- Power Sources for Your NEC Versa
- BIOS Setup
- Updating the BIOS
- NEC Utilities
- Application and Driver CD

Power Sources for Your NEC Versa

The NEC Versa can be powered using three different sources, making it a truly portable system.

Operate your NEC Versa just about anywhere using one of the following power sources:

- the AC adapter connected to an electrical wall outlet (using AC power)
- the battery pack or an optional second battery pack
- the optional Auto adapter (For details about its use, refer to the accessory sheet that ships with the option.)

Read the following sections for specific information about using the NEC power sources.

Using the AC Adapter

Use the AC adapter and power cable that came with your NEC Versa to run your computer on alternating current (AC) power, or to recharge the battery pack. Use the AC adapter whenever a wall outlet is nearby.

Keep the adapter connected whenever possible. The AC adapter charges the battery when it is connected, whether the NEC Versa is powered on or off.

AC adapter



A – AC Adapter
B – Adapter Cable

C – Power Cable

! WARNING Do not attempt to disassemble the AC adapter. The AC adapter has no user-replaceable or serviceable parts inside. Dangerous voltage in the AC adapter can cause serious personal injury or death. The AC adapter is intended for use with a computer and must meet EN609050 standards.

Connecting the AC Adapter

Note The AC power cable type that your system uses depends on the country where you are using it. Contact the local dealer to purchase the correct power cable.

Connect the AC adapter as follows:

1. Connect the AC adapter cable to the power port on the left side of your NEC Versa.
2. Plug one end of the AC power cable into the AC adapter and the other end into a properly grounded 120- or 240-volt, 50- or 60-Hz wall outlet.

Connecting the AC adapter



A – Adapter Cable
B – AC Power Port

C – AC Adapter
D – Power Cable

CAUTION Do not cover or place objects on the AC adapter. Keeping the adapter clear of objects lets the adapter cool properly during use.

Only use the AC adapter that comes with your NEC Versa FX. Although other adapters look similar, using them can damage your system.

Powering On Your System

Power on the system as follows:

1. Locate the latch on the front of the LCD panel, slide it to the right, and raise the panel.
2. Locate the Power button and slide it to the right to turn on system power.

Using the Main Battery Pack

The NEC Versa comes with a rechargeable Lithium-Ion (Li-Ion) battery pack that's easy to install and remove.

Lithium-Ion battery

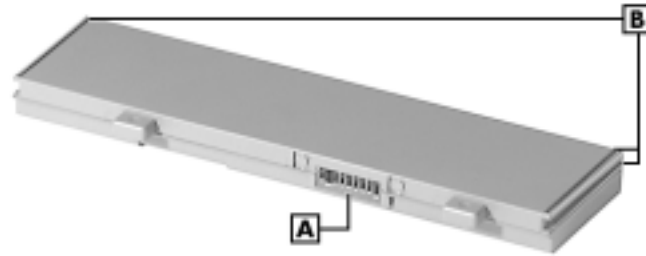

A – Battery Connectors

B – Alignment Grooves

! WARNING To prevent accidental battery ignition or explosion, adhere to the following:

- Keep the battery away from extreme heat.
- Keep metal objects away from the battery connectors to prevent a short circuit.
- Make sure the battery is properly installed in the battery bay.
- Read the precautions printed on the battery.

Determining Battery Status

Your NEC Versa system provides tools to help you keep track of the main (and an optional) battery's power level. If your system is configured (default setting) to display the power icon on the taskbar, an electrical plug displays when the system is connected to an AC power source or a battery icon displays when the system is not connected to an AC power source.

Use the system's power meter to determine battery status. Access the system's power meter in the following ways:

- Move the cursor over the power icon on the taskbar to display the remaining battery power for the system's main battery.
- Right click the power icon on the taskbar to open the power meter or to adjust power properties.
- Double click the power icon on the taskbar to display the remaining power for both the main and optional (if attached) battery.
- Go to Start, Settings, Control Panel, and double click the Power Management icon and select the Power Meter tab.

Low Battery Status

When battery power is low (8% or less), the power LED lights yellow. When battery power is very low (3% or less) the power LED flashes amber. When your system is in a low battery status do one of the following:

- Power off the system, remove the battery pack and replace it with a fully charged battery.
- Leave the battery pack in the system and connect your NEC Versa to the AC adapter and a wall outlet. If you connect the system to AC power and keep the system within standard operating temperatures, the battery recharges in approximately 2–3 hours whether or not you use your system.

Returning the Battery to its Normal State

To return the battery to its normal state, try the following:

- remove and then reinstall the battery
- reinstall the battery in your NEC Versa and fully recharge the battery (to 100%).

Extending Battery Life

While on the road, it is important to be aware of the simple things you can do to extend the life of the system's main battery. One way is to keep the brightness setting low. Use the **Fn+F8** and **Fn+F9** function keys to control the brightness.

Battery Handling

Keep the following in mind when removing or replacing a battery.

- Use only the battery designed for your system in the NEC Versa. Mixing other manufacturers' batteries, or using a combination of very old and new batteries can deteriorate battery and equipment performance.
- Turn off power to the system after use. Keeping system power on can degrade battery performance and shorten battery life.
- Clean the battery terminals with a dry cloth when they get dirty.
- Keep the battery out of the reach of children.

Replacing the Battery

The following symptoms indicate that battery life is nearing an end. Replace batteries that display these symptoms.

- Shorter work times.
- Discoloration, warping.
- Hot to the touch.
- Strange odor.

Replace the battery pack installed in your NEC Versa system as follows.

Note Use the batteries in the NEC Versa computer for which they are designed. Installing another manufacturer's battery, or using a combination of very old and new batteries can deteriorate battery and equipment performance.

1. Save your files, exit Windows, and turn off system power.
2. Close the LCD panel and turn over the system.
3. Slide the battery release latch toward the right side of the system and hold firmly.

Locating the battery bay release latch



A – Lithium-Ion Battery

B – Battery Release Latch

4. Continue to hold the battery release latch as you slide the battery out of the system.

Removing the battery

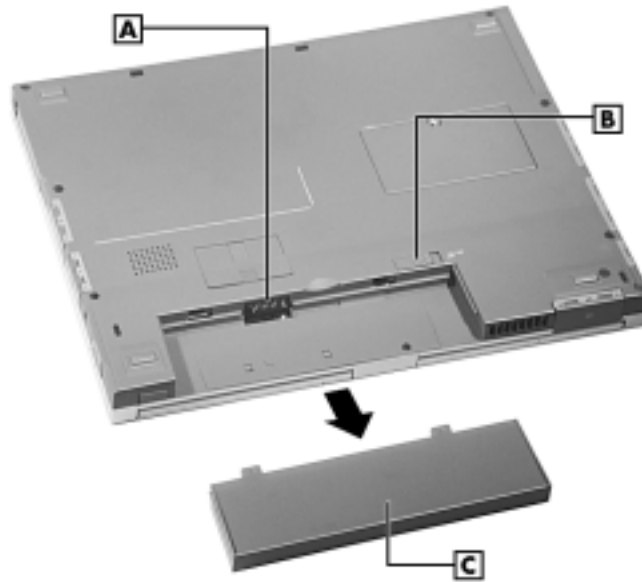

A – Battery Bay Connectors
B – Battery Bay Release Latch

C – Lithium-Ion Battery

5. Insert the new battery as follows:
 - Locate the alignment groove on the edge of the battery.
 - Locate the alignment groove inside the battery bay.
 - Align the grooves on the battery with the grooves in the bay.
 - Slide the battery into the bay until securely locked into place.

Inserting the battery pack

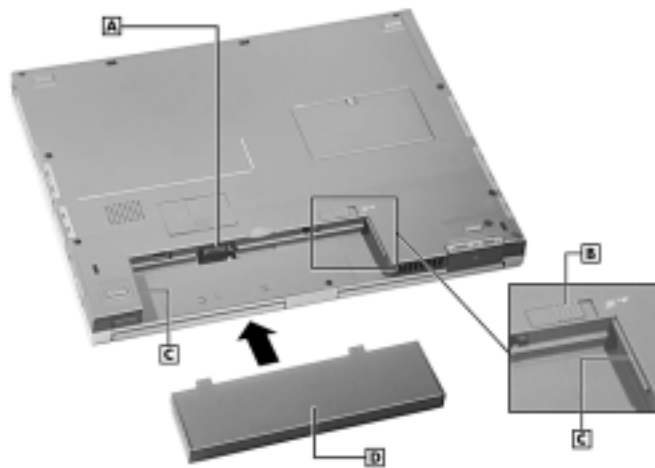

A – Battery Bay Connectors
B – Battery Bay Release Latch

C – Alignment Grooves
D – Lithium-Ion Battery

6. Turn over the system.

Charging the Battery

Charge the main (primary) battery and secondary (optional) battery by simply connecting your NEC Versa FX system to an AC power source. To monitor the charging activity, observe the battery charging LED on the front of the system. The battery charging LED lights as follows:

- Lights amber when the primary battery is charging.
- Blinks amber if the primary battery encounters an error while charging.
- Lights green when the secondary battery is charging.
- Blinks green if the secondary battery encounters an error while charging.

Battery Precautions

To prevent accidental battery ignition, rupture, or explosion, adhere to the following precautions.

 **WARNING** There is a danger of explosion if the battery is incorrectly replaced. Replace only with the same or equivalent type recommended by the manufacturer. Discard used batteries according to the manufacturer's instructions.

To avoid personal injury and property damage, read these battery precautions on handling, charging, and disposing Li-Ion batteries.

- Keep the battery away from heat sources including direct sunlight, open fires, microwave ovens, and high-voltage containers. Temperatures over 140° F (60°C) may cause damage.
- Do not drop or impact the battery.
- Do not disassemble the battery.
- Do not solder the battery.
- Do not puncture the battery.
- Do not use a battery that appears damaged or deformed, has any rust on its casing, is discolored, overheats, or emits a foul odor.
- Keep the battery dry and away from water.
- Keep metal objects away from battery connectors. Metal objects in contact with the connectors can cause a short circuit and damage.

If the battery leaks:

- If the battery leaks onto skin or clothing, wash the area immediately with clean water. Battery fluid can cause a skin rash and damage fabric.
 - If battery fluid gets into eyes, DO NOT rub; rinse with clear water immediately and consult a doctor.
 - Take extra precautions to keep a leaking battery away from fire. There is a danger of ignition or explosion.
-

Precautions for Recharging the Battery

Adhere to the following precautions when recharging the primary or secondary battery.

- Charge the battery for the specified charge time only.
- During charging, keep the environmental temperature between 32°F and 104°F (0°C to 40°C).

System Batteries

Your NEC Versa is equipped with a main, Lithium-Ion battery, and two backup batteries that help to prevent data loss. In addition, your system provides the option to attach a second Lithium-Ion battery to the connector on the bottom of the system, extending battery life when you are away from an AC power source.

Main Battery

The standard Lithium-Ion (Li-Ion) battery provides the main power source in your NEC Versa FX computer. See Specifications for a list of battery specifications. In addition to this battery, the CMOS battery and bridge battery also provide system power.

CMOS Battery

This lithium battery provides battery backup and prevents data loss in the system's complementary metal oxide semiconductor (CMOS) RAM. This memory area contains information on the system's configuration, for example date, time, drives, and memory. The CMOS battery charges when your NEC Versa is connected to AC power. The CMOS battery may discharge completely if the NEC Versa notebook remains unused for approximately two months.

Bridge Battery

The bridge battery saves your system status in Standby mode giving you time to install a fully charged battery or connect to AC power when your battery charge becomes low.



CAUTION Connect your NEC Versa system to AC power for a full 24 hours before using it on battery power for the first time. Doing so insures that the bridge battery is fully charged and that no data is lost during a battery change.

BIOS Setup

Your NEC Versa FX computer comes with a hardware program called BIOS Setup that allows you to view and set system parameters. BIOS Setup also allows you to set password features that protect your system from unauthorized use.

Use BIOS Setup to:

- set the current time and date
- customize your operating system to reflect your computer hardware
- secure your system with a password
- balance your performance needs with power conservation.

Access the BIOS utility at power-on. Just press **F2** when the following prompt appears.

Press <F2> to enter Setup.

When you press **F2** to enter BIOS Setup, the system interrupts the Power-On Self-Test (POST) and displays the current CMOS RAM settings.

If the system detects an error during POST, it prompts you with a double beep and a message: "Press <F1> to resume." If you press **F1**, the system enters BIOS Setup automatically. If you want to fix the error, carefully read the error message that appears above the prompt (taking notes if you want), and press **F2**. You will see this message if your CMOS battery becomes fully discharged.

Pausing the Screen

To pause the screen during POST to view the BIOS revision number and other POST messages, press and hold the Insert key while using the Power button to power on the system.

BIOS Setup Main Menu

After you press **F2**, the system displays the BIOS Setup Main Menu screen, similar to the following.

BIOS Setup Main Menu

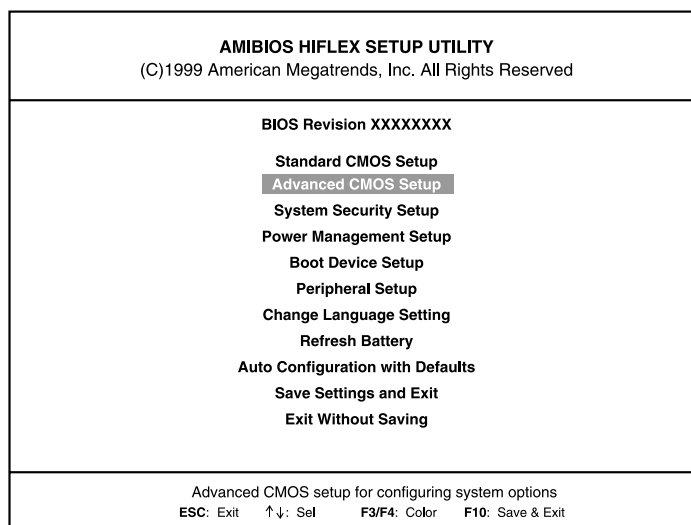

Use the up and down arrow keys (located on the lower right corner of the keyboard) to toggle through the BIOS Setup menu items.

Looking at Screens

BIOS setup screens have three areas as shown next.

Advanced CMOS Setup

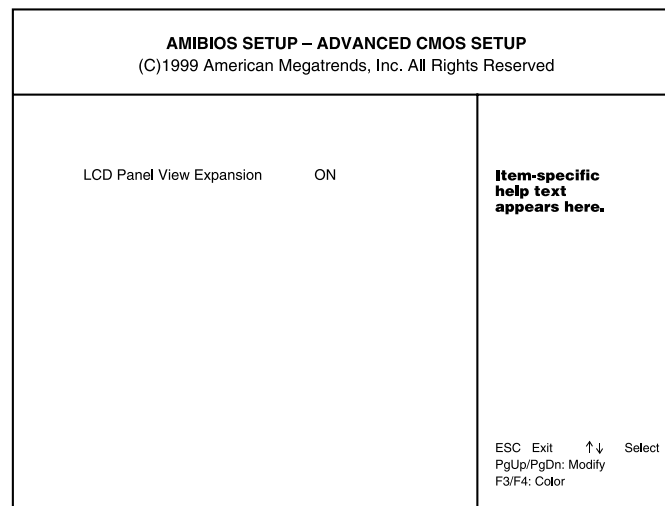

- Parameters — The left side of the screen. This area lists parameters and their current settings.
- Available Options and Help — The right side of the screen. This area lists alternate settings and Help text for each parameter.
- Key Legend — The bottom right corner of the screen. These lines display the keys that move the cursor and select parameters.

Options that are grayed out are not available for the current selection.

Using Keys

The following table lists the BIOS Setup keys and their functions.

BIOS Setup Key Functions

Key	Function
↑ ↓	Moves the cursor between the displayed parameters.
Fn-PgUp/ Fn-PgDn	Toggles through the current parameter settings.
Tab	For some parameter settings, moves the cursor between the subfields. Also moves the cursor to the next line or selection. For example, for System Time, Tab moves the cursor from hour to minute to second.
ESC	Exits the current screen and returns to the Main Menu screen. From the Main Menu screen, displays the prompt, "Quit without saving."
F3/F4	Changes the screen color.
F10	Saves and exits the BIOS Setup utility.

Checking/Setting System Parameters

The BIOS Setup Utility consists of a number of screens, each representing a specific area of the BIOS. The following tables list the BIOS parameters, their factory default settings, alternate settings, and a description of each setting. See the item-specific help that appears on each Setup screen for more details.

The BIOS Setup Utility is broken down as follows:

- Standard CMOS Setup
- Advanced CMOS Setup
- System Security Setup
- Power Management Setup
- Boot Device Setup
- Peripheral Setup
- Change Language Setting
- Refresh Battery
- Auto Configuration with Defaults
- Save Settings and Exit
- Exit Without Saving

Resetting System Parameters

To reset all parameters to the default settings, select Auto Configuration with Defaults from the BIOS Setup Main Menu, use the arrow keys to select **Yes** and press **Enter**.

Standard CMOS Setup

Use the Standard CMOS Setup screen to view the System Time, System Date and to modify drive parameters and related settings.

Standard CMOS Setup

Parameter	Default Setting	Alternate Setting(s)
Date	mm/dd/yy	
System Memory		(automatically detected)
Time	hh/mm/ss	
Diskette Drive A	1.44 MB, 3.5	Not installed, 1.44 MB
Internal	Auto	CDROM, User Defined, Not installed
External	Auto	CDROM, User Defined, Not installed
Boot Sector Virus Protection	Disabled	Enabled

- Date — Sets your NEC Versa's calendar month, day and year. The calendar clock is year 2000-compliant. These settings remain in memory even after you turn off system power.

To set the date use the **Tab** or arrow keys to move from field to field. Use the **Fn-PgUp** or **Fn-PgDn** key to change the numbers within each field.

- System Memory — Displays the amount of system memory currently installed in your system.
- Time — Sets the time, enter the current hour, minute, and second in *hr/min/sec*, 24-hour format.

To set the time use the **Tab** or arrow keys to move from field to field. Use the **PgUp** or **PgDn** key to change the numbers within each field.

- Diskette Drive — Designates the drive type for your diskette drive.
- Internal Drive — Assigns devices to the internal drive in your system.
- External Drive — Assigns devices to the external drive in your system.
- Boot Sector Virus Protection — Write protects the boot sector of the hard disk drive to avoid infection by some virus types.

Advanced CMOS Setup

Use the Advanced CMOS Setup to set the following functions.

Advanced CMOS Setup

Parameter	Default Setting	Alternate Setting(s)
LCD Panel View Expansion	Off	On

LCD Panel View Expansion — Specifies whether the panel view is reduced/off or expanded/on.

System Security Setup

Use the System Security Setup to establish system passwords.

System Security Setup

Parameter	Default Setting	Alternate Setting(s)
Security Mode	Password	
Assign Supervisor Password	Press Enter	
Assign User Password	Press Enter	
Boot Password Required	No	Yes
Resume Password Required	No	Yes
Assign HDD Password	Press Enter	
Internal HDD password	Disabled	Enabled

- Select Security Mode — Allows you to select your security mode.

-
- Assign Supervisor Password — Establishes password protection for entering the BIOS setup utility, booting the system, and resuming from Standby. (Resume from Standby, not applicable in Windows 98 with ACPI.)
 - Assign User Password — Establishes a user password once a supervisor password is set.
 - Boot Password Required — Indicates whether or not a password is required during system boot.
 - Resume Password required — Indicates whether or not a password is required during system resume. Boot Password must be defined to activate this parameter. (Not applicable in Windows 98 with ACPI.)
 - Assign HDD Password — Allows you to assign a password to allow or restrict access to the hard disk drive contents.
 - Internal HDD Password — Enables or disables the HDD password.

Security Protection

To establish password protection for entering the BIOS Setup utility or accessing the system at startup, you must set the supervisor password before setting a user password.

- To enter a password simply select Assign Supervisor Password, enter the password, re-enter the password to confirm, and press any key to continue. Repeat the procedure to set the user password.
- To initiate password protection while you step away from your system, simply press **Ctrl, Alt, Backspace**. The Caps lock and Scroll lock LEDs alternately flash indicating that you must enter a password to resume operation.

To establish password protection for resuming from Standby or Hibernation modes, you must do the following:

- Set a Windows password in Control Panel, Password Properties, Change Passwords.
- Enable the option, "Prompt for password when the computer goes off standby,;" in Control Panel, Power Management Properties, Advanced.

Power Management Setup

Your Versa FX system ships with the Windows 98 operating system that uses the Advanced Configuration and Power Interface (ACPI) to control most power management functions through the Power Management Properties screen in Windows. The BIOS Power Management Setup screen is described next.

Note In Windows 98, the term “Standby” is functionally the same as the term “Suspend” that is referenced in the BIOS Setup utility.

Power Management Setup

Parameter	Default Setting	Alternate Setting(s)
System Switch	Power Button	Sleep Button
Power Management under AC	Off	On
Power Savings Level	Longest Life	High Perform/Custom/Off
CPU Speed Control ¹	50%	12.5, 25, 100%
Hard Disk Timeout ¹	2 minutes	5/30/45 sec; 1/4/6/8/10/15 min. Off
Video Timeout ¹	2 minutes	30/45 sec.; 1/4/6/8/10/15 min. Off
Peripheral Timeout ¹	On	Off
Audio Device Timeout ¹	On	Off
Standby Timeout ¹	4 minutes	Off/1/2/6/8/10/15 min.
Auto Suspend Timeout ¹	10 minutes	Off/5/15/20/25/30 min.
LCD Suspend	Disabled	Enabled
Suspend Option	Suspend	STF
Auto Save-to-File	Enabled	Disabled
Panel Brightness	Auto	User Defined
Suspend Warning Tone	Enabled	Disabled
Remote Power On	Enabled	Disabled
Wake Up Alarm	Disabled	Enabled
Resume Alarm Time ²	Off	Set time in 5 min. increments when Wake Up Alarm is set.

¹ Available when power savings is set to Custom.

² Resume alarm time is selectable when wake up from suspend alarm is set.

- System Switch — Sets the Power button as a power switch or a sleep button.
- Power Management Under AC — Specifies whether to enable power management features when AC power is in use. When AC power is connected to your NEC Versa system, power management is usually disabled. If you enable this parameter, the system automatically activates the power management profile you set, even when AC power is used.

- **Power Savings Level** — Specifies one of four levels of power management. (Not applicable in Windows 98 with ACPI.)
 - **High Performance** — provides good battery life and best performance with only minimal power conservation. Use while on the road or traveling short distances.
 - **Longest Life** — provides best battery life, the maximum amount of power savings, and good performance. Use while traveling long distances.
 - **Off** — disables power management and all device timeouts. Works well in an office environment while powering your NEC Versa with AC power.
 - **Custom** — lets you define power management levels and specific device timeouts according to your own needs and present environment. Custom lets you set the following timeouts.

Custom Timeout Options

Option	Definition
CPU Speed Control	Sets CPU performance at one of four levels.
Hard Disk Timeout	Sets the time delay before your hard disk powers down.
Video Timeout	Sets the time delay before your video powers off.
Peripheral Timeout	Sets the time delay before your peripherals are controlled by power management.
Audio Device Timeout	Sets the time delay before your audio device powers off.
Standby Timeout	Selects the system standby timeout period.
Auto Suspend Timeout	Defines how much time elapses from the time the system enters Standby mode to the time the system automatically enters Suspend Mode.

- **LCD Suspend** — Allows you to suspend/resume when the LCD panel is closed. (Not applicable in Windows 98 with ACPI.)
- **Suspend Option** — Specifies either Suspend or Save to File (STF) as the default power management mode.
- **Automatic STF** — Enables the system, after 30 minutes in Suspend mode, to save the current working environment to a special file on the hard disk and to power down the system.
- **Panel Brightness** — Selects the LCD screen brightness.
- **Suspend Warning Tone** — Specifies whether the system warning tone sounds when Suspend mode starts. It is best to keep this option enabled. (Not applicable in Windows 98 with ACPI.)
- **Remote Power On** — Allows the serial port modem or LAN board to wake the system on a ring signal.
- **Wake Up from Suspend Alarm/Resume Alarm Time** — Allows the alarm to resume the system from suspend. Designates the time parameter in five minutes increments. (Not applicable in Windows 98 with ACPI.)

Boot Device Setup

Boot Device Setup allows you to define the following functions.

Boot Device Setup

Parameter	Default Setting	Alternate Setting(s)
Quick Boot	Enabled	Disabled
Silent Boot	Enabled	Disabled, Black
Boot Display Device	Simul. Mode	CRT only, LCD only
BootUp NumLock	Off	On
1 st Boot Device ¹	CDROM	Disabled/1 st Fnd IDE/ Floppy/Network
2nd Boot Device ¹	Floppy	Disabled/1 st Fnd IDE/ CDROM
3rd Boot Device ¹	1 st Fnd IDE	Disabled/Floppy/CDROM
Try Other Boot Devices	Yes	No

¹ Bootable device when set to IDE hard drive. Only one IDE device is allowed to be bootable.

- Quick Boot — Specifies whether the system performs all tests during system boot.
- Silent Boot — Specifies whether to display the NEC logo during the system boot.
- Boot Display Device — Specifies the display device(s) for system boot messages.
- BootUp NumLock — Specifies whether NumLock is On or Off at system startup.
- Boot Devices — Specifies the sequence of boot devices.
- Try other Boot Devices — Specifies whether or not the system attempts to boot from other devices if all selected boot devices fail to boot.

Peripheral Setup

In the Windows 98 environment, most device management is controlled through the Windows device manager. Use the Windows device manager to enable and disable devices on your NEC Versa FX system.

The Peripheral Setup menu displays the connection locations between the system and the Input/Output (I/O) ports and lets you specify different port assignments as needed.

Peripheral Setup

Parameter	Default Setting	Alternate Setting(s)
USB Controller	Disabled	Enabled
AC' 97 Modem	Enabled	Disabled
Internal Hard Drive	Enabled	Disabled
Parallel Port	Auto	Disabled/LPT1/LPT2 (PnP OS Setup ¹)
Parallel Mode	Bi-Dir	Uni-Dir/EPP/ECP
IR Serial Port	Disabled	Auto/(PnP OS Setup ¹) COM2,IRQ3/COM3,IRQ4/ COM4,IRQ3

¹ Appears only when configured by the Windows 98 device manager.

Note If you disable a device in Peripheral Setup, you cannot enable or assign it using the Windows 98 device manager. The device will not be listed in the Windows device list. To control the device using the Windows device manager, select any setting other than Disabled in Peripheral Setup.

Peripheral Setup allows you to define the following functions.

- USB Controller — Enables or disables the USB controller.
- AC' 97 Modem — Enables or disables the internal modem.
- Internal Hard Drive — Enables or disables the internal hard drive.
- Parallel Port/Parallel Mode — Disables or reassigns the parallel port and select a parallel port mode.
- IR Serial Port — Enables, disables or reassigns the IR serial port.

Other BIOS Setup Options

BIOS Setup offers other options, including the following:

- Change Language Setting — Controls the BIOS setup language display. English, Japanese, and French are the available options.
- Refresh Battery — Launches the Refresh Battery utility. Once launched, the utility fully discharges your battery to eliminate any residual memory effect. Once refreshed, your battery is conditioned to recharge to its full capacity. To recharge the battery, connect your NEC Versa to AC power. This process may take up to four hours to complete.
- Auto Configuration with Defaults — Loads default configuration settings.
- Save Settings and Exit — Accepts changes made to current settings, saves to CMOS, and exits BIOS Setup.
- Exit Without Saving — Reverts to previously selected settings and exits Setup.

Updating the BIOS

The BIOS is code transmitted onto your system's microprocessor, or central processing unit (CPU). As indicated in this chapter, you use the BIOS Setup utility to configure your system's software and hardware features. Only use the BIOS Update Diskette for your specific model, to update your NEC Versa system BIOS.

Note You only need to update the BIOS if NEC CSD makes significant improvements or fixes to the current system BIOS. Your authorized NEC CSD dealer or NEC CSD Support Services representative can help you determine this.

To update the system BIOS you must:

- Obtain the BIOS Update
- Prepare the BIOS Update Diskette
- Enable the BIOS Flash Switch Setting
- Perform the BIOS Update
- Disable the BIOS Flash Setting

Obtaining the BIOS Update

If you are informed that the default BIOS needs an update, contact NEC CSD Support Services at (800) 632-4525, Fax (801) 981-3133, or access the web site, www.nec-computers.com to obtain a copy of the BIOS update.

Note If you purchased and are using this computer outside the U.S. or Canada, please contact a local NEC CSD or dealer in your country.

Reference the booklet, "Getting Services and Support in Asia, Australia, and Europe," to find out how to contact the local office in your country.

Preparing the BIOS Update Diskette

Before using the BIOS update diskette you must make the diskette BIOS flash ready. Refer to the **readme.txt** file on the diskette before using the diskette.

Follow these instructions to prepare the BIOS Update Diskette.

1. Scan your hard drive for any computer viruses.
2. Enable the diskette for write access.
3. Insert the diskette into the external floppy diskette drive.
4. Type **a:install** (where a: is the floppy diskette drive) at the DOS prompt and follow the on-screen instructions.

Install.bat copies the DOS system files from your hard drive onto the BIOS Update Diskette to make it BIOS flash ready.

The system prompts you when the process is complete.

5. Scan the BIOS Update Diskette for computer viruses.

The diskette is ready for use.

6. Follow the instructions later in this chapter, “Enabling the BIOS Flash Switch.”

Enabling the BIOS Flash Switch

Before performing the BIOS update, be sure to enable BIOS flash switch. Set switch 5 to “ON” before performing the BIOS update.

Follow these steps to enable the BIOS flash switch.

1. Make sure the system is powered off and that no peripheral devices are attached.
2. Turn over the system and locate the memory module bay.

Locating the memory module bay

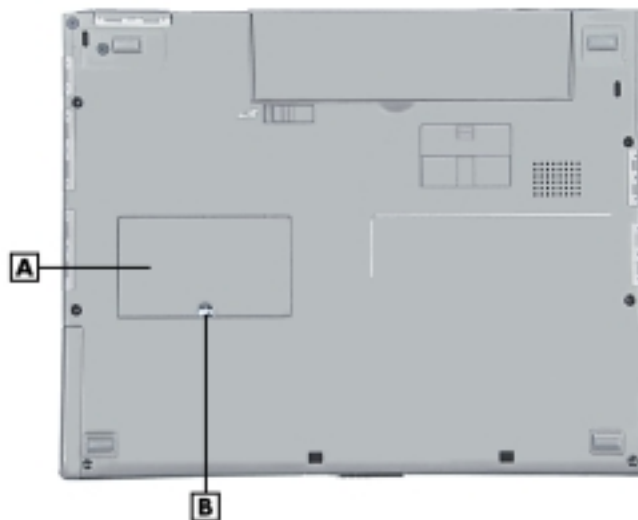

A – Memory Module Bay Cover

B – Screw

-
3. Remove the screw and bay cover.
 4. Locate the dip switch block. Using a fine-tipped object, change switch 5 to “ON” to enable BIOS flash.

⚠ CAUTION Never use a pencil to change switch settings. Residue from the pencil can damage the system.

BIOS flash switch enabled

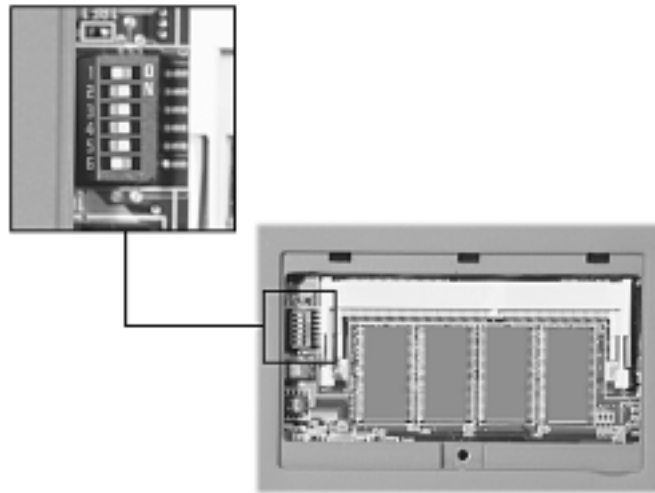

Dip switches 2, 3, 4, and 5 set to “On”

Note The system memory expansion slots are also located here. Therefore, if you need to install/replace SO-DIMM modules, you might want to do so while the system is already disassembled.

5. Replace the memory module bay cover and screw.
6. Turn over the system.
7. Follow the instructions later in this chapter, “Performing the BIOS Update.”

Performing the BIOS Update

Follow these steps to perform the BIOS update.

1. Make sure that the computer is operating under AC power and that the power is off. Insert the BIOS Update diskette into the floppy diskette drive.
2. Power on the computer with the diskette in the floppy diskette drive. The computer boots and automatically loads the utility. Read the message that displays and follow the instructions.
3. Press **Enter** to continue.

The utility checks the currently installed BIOS version and the diskette’s BIOS version. The Main menu appears.

-
4. Use the arrow keys to highlight the “Display BIOS Version” option on the Main Menu. Use this option to check the currently installed BIOS version and the version of the new replacement BIOS.

Press any key to return to the Main menu.

5. Highlight the “Install New BIOS” option and press **Enter**.
6. Press **Y** and then press **Enter**. After a brief pause, a message appears telling you to remove the diskette from the floppy drive.
7. Remove the diskette and press any key to continue. The utility updates the BIOS.
Power off your computer. The next time you power on your computer, you will have the latest NEC Versa FX computer BIOS revision level.
8. Enter Setup to restore the default parameter settings.
9. Be sure to modify any custom settings that you may have configured.
10. Disable the BIOS flash switch. Change switch 5 back to “OFF” after completing the BIOS update. For details about enabling and disabling the BIOS flash switch, see the section earlier in this chapter, “Enabling the BIOS Flash Switch.”

NEC Utilities

NEC CSD provides several programs and routines designed to make your NEC Versa run more efficiently.

The NEC utilities include:

- NEC Customize Utility
- HDPREPEZ Utility

NEC Customize Utility

In Windows 98 systems the NEC Customize utility gives you the option to install or launch:

- Application and Driver CD — Use this option to install a variety of software applications, drivers, utilities, internet browsers, and the NEC Info Center.
- NEC Versa FX Warm Connect Utility — Use this option to take advantage of warm connecting the CD-ROM drive to your NEC Versa FX computer.

NEC Customize Utility Screen

The NEC Customize utility screen consists of the following.

- A window at the top half of the screen lists the available options.
- The window below the options list displays a description of each option when the option is highlighted.
- The Launch button initiates a selected option when clicked.
- The More Info button provides an overview of the NEC Customize utility.
- The Exit button closes the NEC Customize utility.

Using the NEC Customize Utility

Follow these steps to use the NEC Customize utility.

1. Double click the NEC Customize icon.
2. From the display window, select the desired option.
3. Click Launch to initiate the selected option.
4. Follow the on-screen instructions to process the selected option.

For some of the selected options you are prompted to reboot your system.

5. If necessary, click Exit to close the NEC Customize dialog box.

HDPREPEZ Utility

The HDPREPEZ utility automatically configures your NEC Versa's system's save-to-file (STF) area on the hard disk drive.

Note For more details about the HDPREPEZ utility, see the HDPREPEZ.TXT file in the NECUTILS/HDPREP directory.

Using the HDPREPEZ Utility

In Windows 98, run the HDPREPEZ utility if you increase the memory capacity in your NEC Versa beyond the factory installed base memory.

Follow these steps to run the HDPREPEZ utility.

1. Go to Start, Shut Down, Restart the computer in DOS mode.
2. At the c: prompt, type **LOCK C:** and press **Enter**.
A message displays asking you to confirm your command.
3. Press the indicated key to confirm your command.
4. At the c: prompt, type **cd \necutils\hdprep** and press **Enter** to change to the \necutils\hdprep directory.
5. Type **HDPREPEZ** and press **Enter**. The utility automatically prepares your NEC Versa for the newly installed memory.
6. Power off your system and then power on. A file, large enough to accommodate your system's memory is created on the hard disk drive.

Application and Driver CD

A variety of third-party software applications, drivers, utilities, internet browsers and the NEC Info Center are provided on the Application and Driver (A&D) CD for the NEC Versa FX that ships with your system. Some of the drivers are already installed as part of your operating system environment. The additional software on the Application and Driver CD lets you take full advantage of your system resources.

Use the Application and Driver CD to install applications, drivers, utilities, internet browsers, and the NEC Info Center. Some software applications install their own desktop icon allowing quick access to the application. You can also access an application through the Start, Programs menu.

Launching the Application and Driver CD with Windows 98

Follow these procedures to launch the Application and Driver CD using NEC Customize with Windows 98.

1. Insert the Application and Driver CD into the CD-ROM drive.
2. Double click the NEC Customize icon, if necessary.
3. Highlight Launch Application and Driver CD.
4. Click launch.

The Application and Driver CD dialog box appears.

Application and Driver CD Dialog Box

The Application and Driver CD dialog box consists of the following components.

- Selection Tabs — Located just below the title bar, each tab represents a software category. The selection tabs include applications, drivers, utilities, internet browsers, and the NEC Online Documentation.
- Description — Located in the bottom portion of the dialog box, the text describes the selected or highlighted software category or application, driver, etc.
- Install — Clicking the Install button installs the selected software.
- Exit — Clicking the Exit button closes the Application and Driver CD dialog box.

Installing the Application and Driver CD Software

Once the Application and Driver CD dialog box appears, follow these steps to install the desired software.

1. Click the selection tab of your choice.
2. Click the desired application, driver, or utility.
3. Click the Install button to install your selection.

Follow the on-screen instructions to install your selection.

4. Click Exit to close the Application and Driver CD dialog box.
5. Remove the CD from the CD-ROM drive when the installation is complete.

3

Disassembly and Reassembly

- Required Tools and Equipment
- Disassembly
- Reassembly

Required Tools and Equipment

All NEC Versa FX corrective maintenance procedures can be performed using the following tools:

- Tweezers
- Small flat-head screwdriver
- Small Phillips screwdrivers (# 1 and # 0)
- Right-angled dentist-style probe.

Disassembly

This section contains step-by-step disassembly procedures for the system. Reassembly is the reverse of disassembly. Each procedure is supported by a simplified disassembly illustration to facilitate removal. The Illustrated Parts Breakdown and parts lists for the system unit are shown in Chapter 5.

For complete disassembly of the system, follow the disassembly instructions that follow.

Note The following instructions cover two slightly different disassembly procedures. Some earlier units did not have a user-removable hard drive. Follow the instructions carefully to properly disassemble the systems.

When disassembling the system unit, follow these general rules.

- Turn off the system and disconnect all power and all options, including the AC adapter (if connected) and battery pack (see the procedures that follow).
- Do not disassemble the system into parts that are smaller than those specified in the procedure.
- Label all removed connectors. Note where the connector goes and in what position it was installed.

Battery

Replace the battery pack installed in your NEC Versa FX system as follows.

Note Use the batteries in the NEC Versa computer for which they are designed. Installing another manufacturer's battery, or using a combination of very old and new batteries can deteriorate battery and equipment performance.

1. Save your files, exit Windows, and turn off system power.
2. Close the LCD panel and turn over the system.

-
- Slide the battery release latch toward the right side of the system and hold firmly.

Locating the battery bay release latch



A – Lithium-Ion Battery

B – Battery Release Latch

- Continue to hold the battery release latch as you slide the battery out of the system.

Removing the battery

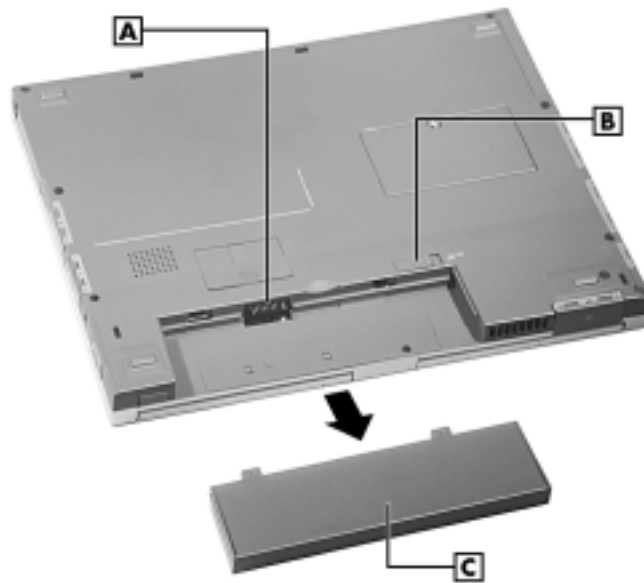

A – Battery Bay Connectors
B – Battery Bay Release Latch

C – Lithium-Ion Battery

Memory Module and Switch Settings

Use the following steps to remove the memory module and access the switch settings.

1. Close the LCD panel.
2. Turn over the system and locate the memory module bay.

Locating the memory module bay

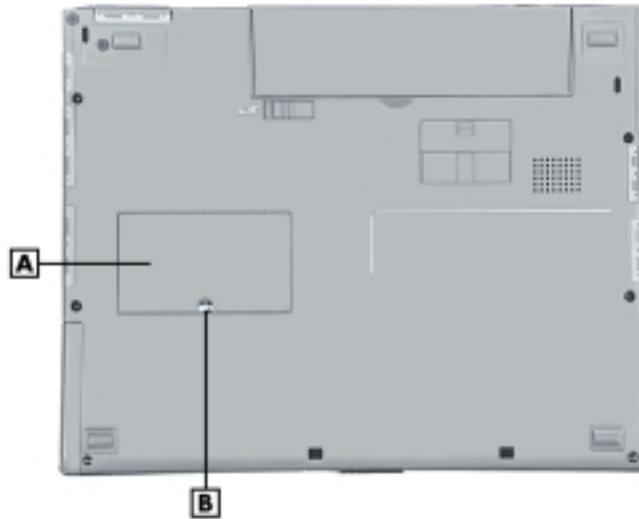

A – Memory Module Bay Cover

B – Screw

3. Remove the screw and bay cover.
4. Locate the SO-DIMM and proceed as follows:
 - Press the locking tabs away from the sides of the SO-DIMM and hold while gently lifting on the edge of the SO-DIMM.
 - When the edge of the SO-DIMM pops up and is at approximately a 60 degree angle, pull the SO-DIMM from the socket.

Removing an installed SO-DIMM



Note The system switches are also located in the memory module bay. Therefore, if you need to set any system switches, do it while the system is already disassembled.

Switch Settings

A six-position dip switch is located on the bottom of the system in the memory module bay. The following list identifies each switch setting and its function.

- Switch 1, Password Override Switch — The default setting is “OFF.” If you forget your password and cannot access the data on your NEC Versa, change the setting to “ON” and your current password is erased.
- Switch 2 — Keyboard select; Default is “ON” for U.S. 85 key keyboard.
- Switch 3 — Reserved for factory use; Default is “ON.”
- Switch 4 — Keyboard select; Default is “ON” for U.S. 85 key keyboard.
- Switch 5 — BIOS flash enable; Default is “OFF” (disable). Before updating your BIOS, change the setting to “ON.”
- Switch 6 — Logo select; Default is “OFF” for U.S.

Default switch settings

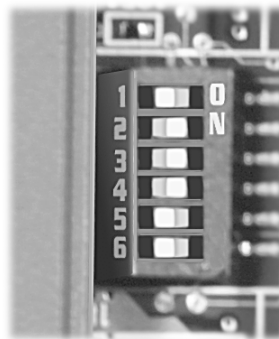

Keyboard

Use the following steps to remove the keyboard assembly.

1. Make sure that the system is powered off and that no peripheral devices are attached.
2. Locate the three keyboard locking tabs: one on the upper left of the keyboard, one above the F8 key, and the other on the upper right of the keyboard.

Locating the keyboard locking tabs

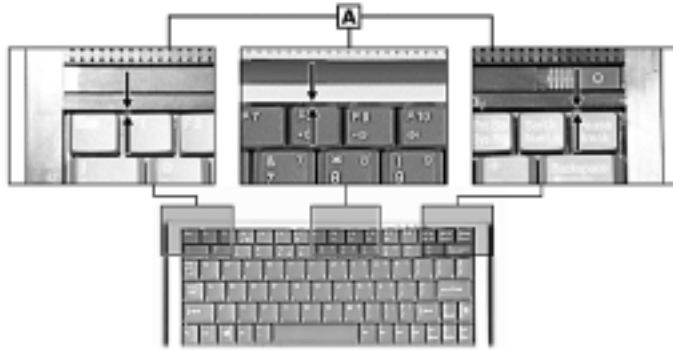

A – Locking Tab

3. Using a small flat-head screwdriver, release the locking tabs by pushing them toward the back of the system.
4. With the tabs released, carefully lift the keyboard assembly out of the system. Disconnect the keyboard cable from connector P8 on the main board.

VersaGlide Assembly

Use the following procedure to remove the VersaGlide assembly.

1. Close the LCD panel and turn the system over.
2. Locate and remove the two bottom screws securing the front cover assembly to the system.

Locating/Removing the bottom screws

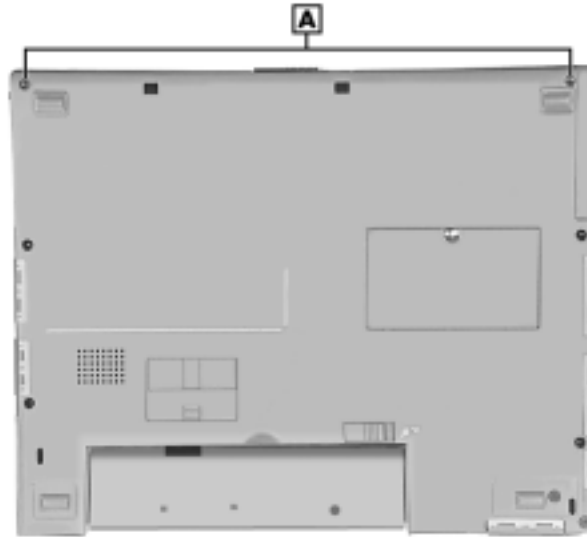

A – Screw

3. Turn the system over and open the LCD panel. Locate and remove the two top screws securing the front cover assembly to the system.

Locating/Removing the top screws



A – Screw

-
4. Slowly remove the front cover assembly by unsnapping the sides from the system base unit. Do not lift the front cover away from the system.
 5. Disconnect the two cables from connectors P9 and P10 from the main board. Slide the cables out from under the bar and lift the front cover away from the system.
 6. Turn the front cover over and locate the VersaGlide locking tabs.

Locating the VersaGlide locking tabs

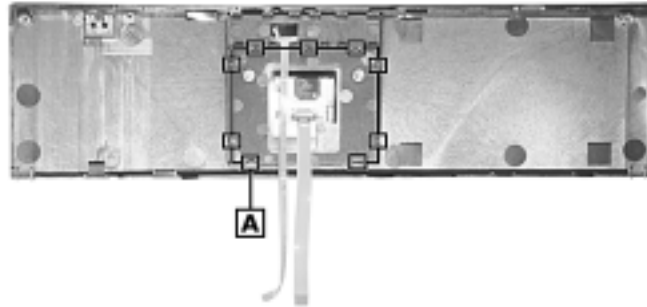

A – Locking Tab

7. Remove the VersaGlide from the front cover by pushing in the locking tabs.

Top Cover

Use the following procedure to remove the top cover assembly.

1. Close the LCD panel and turn the system over.
2. Remove the screw in the battery bay.
3. Locate and remove the screws securing the top cover to the system. Remove the foot closest to the battery bay and remove the screw under the foot.

Locating/Removing the six screws

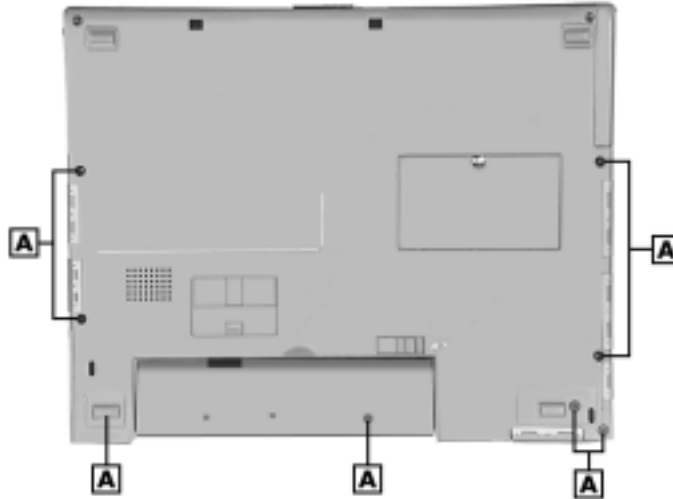

A – Screw

4. Turn the system over and open the LCD panel as far as it will go.
5. Remove the keyboard and the front cover assembly from the system.
6. Carefully pull off the Power button.

-
7. Locate and remove the four screws securing the top cover assembly.

Locating/Removing the four screws



A – Screw

8. Remove the Internet key cable from connector P22 on the main board.
9. Lift the top cover assembly up and slightly to the right from the system.

Hard Disk Drive

Use the following steps to remove the internal hard disk drive.

1. Remove the keyboard and front cover assembly from the system.
2. The hard disk drive is located in the right-side bay under the front cover. No screws secure the drive. Remove the drive as follows.
 - Disconnect the hard disk drive cable from connector P16 on the main board.
 - Slightly lift the drive out of the bay.

- Carefully remove the drive cable connector from the hard disk drive.

Removing the hard disk drive

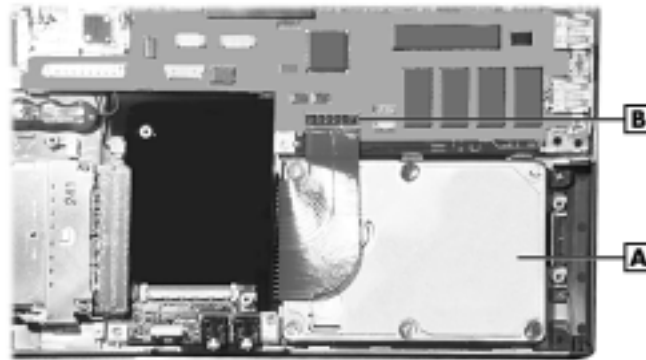

A – Hard Disk Drive

B – Hard Disk Drive Cable Connector

PC Card Assembly

Use the following procedure to remove the PC card assembly.

1. Remove the keyboard, front cover assembly, and top cover assembly from the system.
2. The PC card assembly is located in the left-side bay under the front cover. Remove the PC card assembly as follows:
 - Remove the four screws securing the assembly to the system.
 - Pull up the assembly to disconnect it from the I/O board.
 - Lift the assembly out of the system.

Removing the PC card assembly

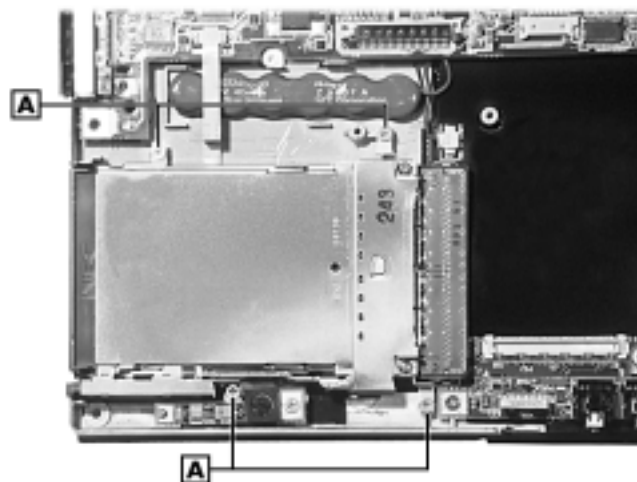

A – Screw

LED Status Board

Use the following steps to remove the LED status board.

1. Remove the keyboard, front cover assembly, top cover assembly, and PC card assembly from the system.
2. Disconnect the LED status board cable from connector P23 on the main board.
3. Locate and remove the screw that secures the board to the system.

Locating/Removing the LED status board screw

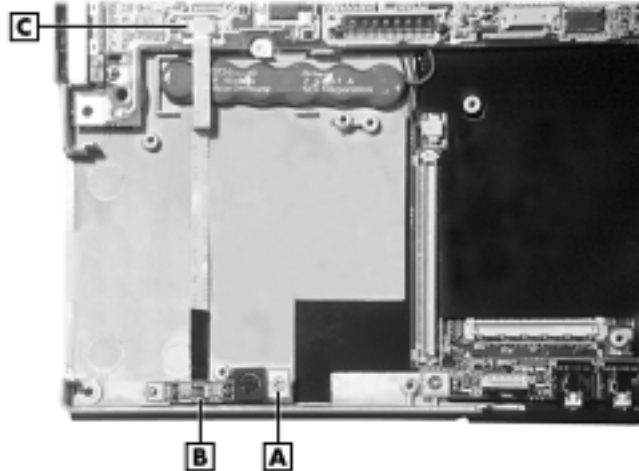

A – Screw

C – LED Status Board Cable Connector

B – LED Status Board

4. Lift the LED status board out of the system.

IR/Sound Board

Use the following procedure to remove the IR/sound board.

1. Remove the keyboard, front cover assembly, top cover assembly, and PC card assembly from the system.

-
2. Locate and remove the two screws that secure the IR/sound board to the system. Lift the board out of the system.

Removing the IR/sound board

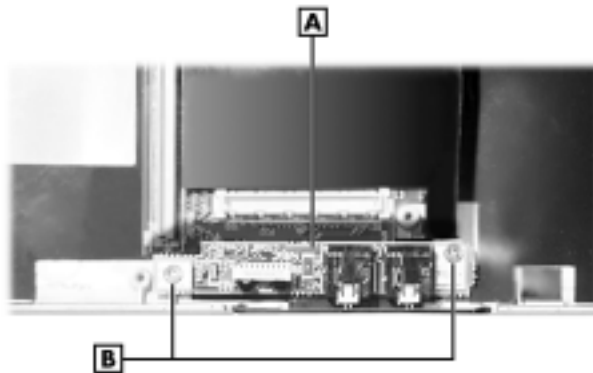

A – IR/Sound Board

B – Screw

Bridge Battery

Use the following steps to remove the bridge battery.

1. Remove the keyboard, front cover assembly, top cover assembly, and PC card assembly from the system.
2. Disconnect the battery from connector P20 on the connector board.
3. Lift the battery out of the system.

Removing the bridge battery

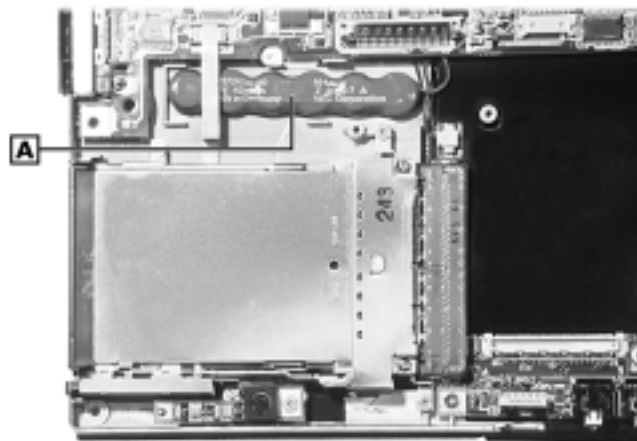

A – Bridge Battery

Speakers

Use the following procedure to remove the speakers.

1. Remove the keyboard, front cover assembly, and top cover assembly from the system.
2. Locate the two speakers in the upper left corner and upper right corner inside the system.

Locating the speakers

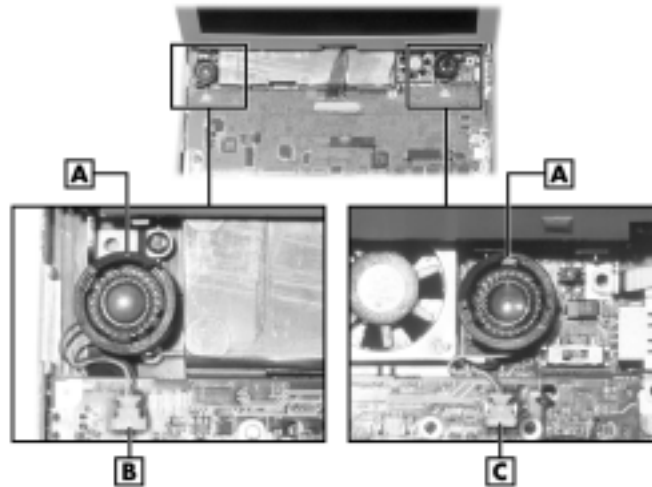

A – Speaker
B – Connector P18

C – Connector P19

3. Disconnect the speaker cables from connector P18 and connector P19 on the main board.
4. Lift the speakers out of the system.

Main Board, Modem Board, and CMOS Battery

Use the following steps to remove the main board, modem board, and CMOS battery.

1. Remove the keyboard, front cover assembly, top cover assembly, hard disk drive, and PC card assembly from the system.
2. Disconnect the LCD panel cable from connector on the main board.

-
3. Locate and remove the screws that secure the LCD panel to the system.

Locating/Removing the LCD panel screws



A – Screw

4. Locate and remove the screw securing the fan plate.

Locating/Removing the fan plate screw

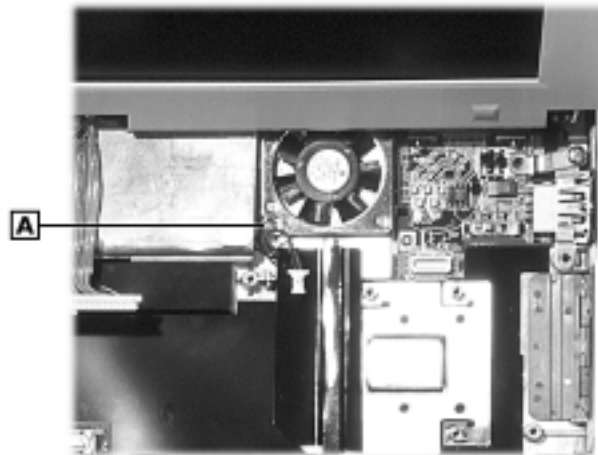

A – Screw

5. Locate and remove the four screws that secure the main board in the system.

Locating/Removing the main board screws

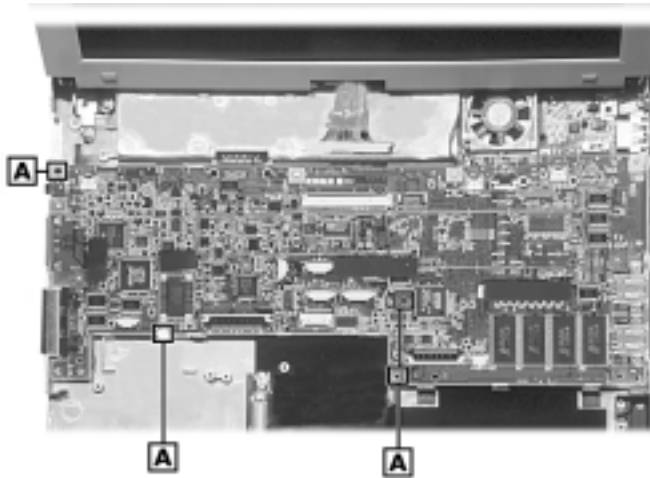

A – Screw

6. Carefully lift the main board.
7. Lift and remove the video/USB board.
8. Disconnect the connector board from the main board.
9. Turn the main board over. Locate and remove the two screws that secure the modem board to the main board.

Locating/Removing the modem board screws

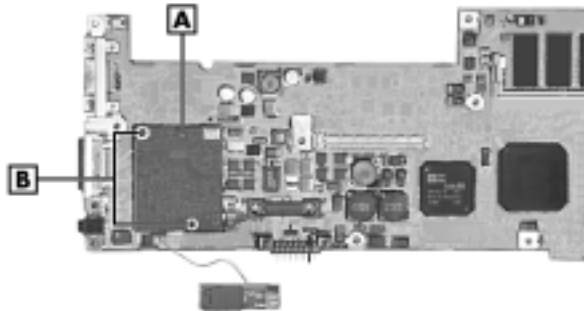

A – Modem Board

B – Screw

10. Carefully disconnect the modem board by pulling it out of connector P3 on the main board.
11. Disconnect the modem port cable from connector J1 on the modem board.

-
12. Locate the CMOS battery. Disconnect the cable from connector P15 on the main board and lift the CMOS battery off of the main board.

Removing the CMOS battery

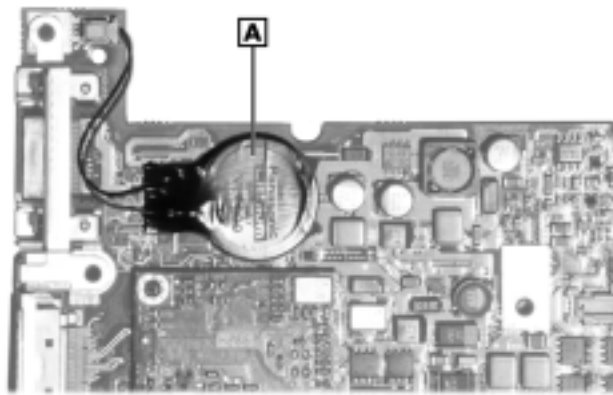

A – CMOS Battery

Reassembly

Reassembly is the reverse of the disassembly process. Use care to insure that all cables and screws are returned to their proper positions.

4

System Board Layout

- LED Status Board
- IR/Sound Board
- Connector Board
- Video/USB Board
- Main Board

This following figures show the system boards and connector locations.

LED Status Board

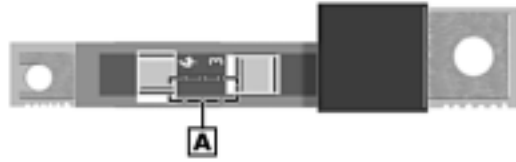

A – Connector P40 (back side)

IR/Sound Board

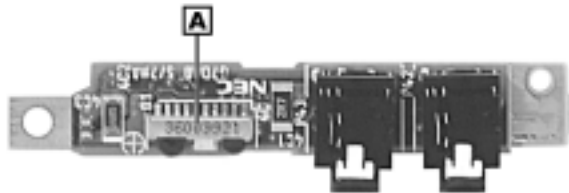

A – Connector P41 (back side)

Connector Board

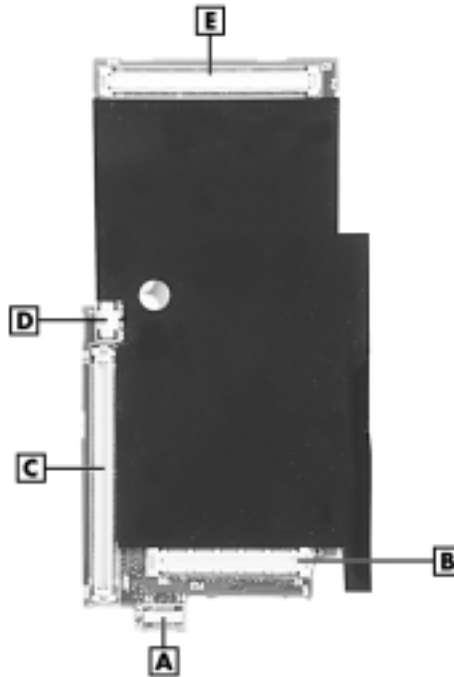

A – Connector P34
B – Connector P32
C – Connector P33

D – Connector P20
E – Connector P31

Video/USB Board

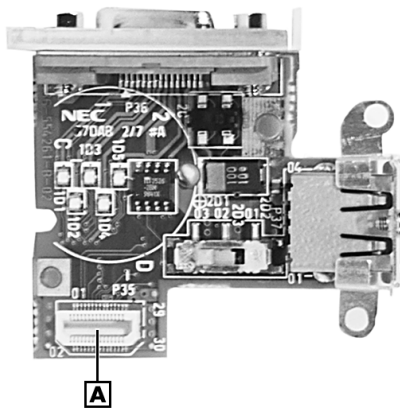

A – Connector P35

Main Board

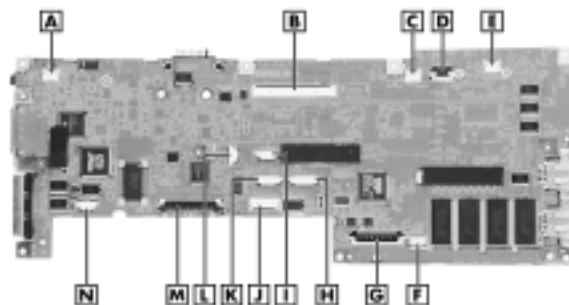

- | | |
|-------------------------|-------------------|
| A – Connector P18 | H – Connector P26 |
| B – LCD Cable Connector | I – Connector P9 |
| C – Connector P24 | J – Connector P27 |
| D – Connector P22 | K – Connector P25 |
| E – Connector P19 | L – Connector P10 |
| F – Connector P28 | M – Connector P8 |
| G – Connector P16 | N – Connector P23 |

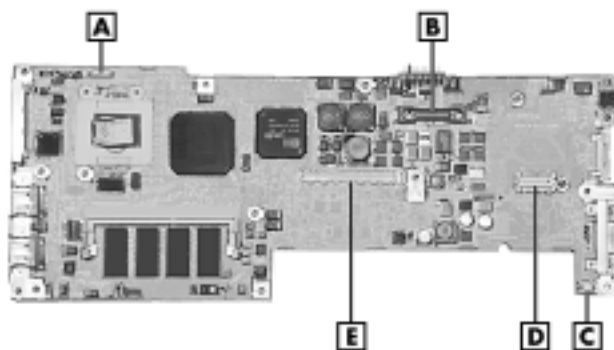

- | | |
|-------------------|-------------------|
| A – Connector P17 | D – Connector P3 |
| B – Connector P12 | E – Connector P21 |
| C – Connector P15 | |

5

Illustrated Parts Breakdown

- Illustrated Parts Breakdown
- Parts List

Illustrated Parts Breakdown

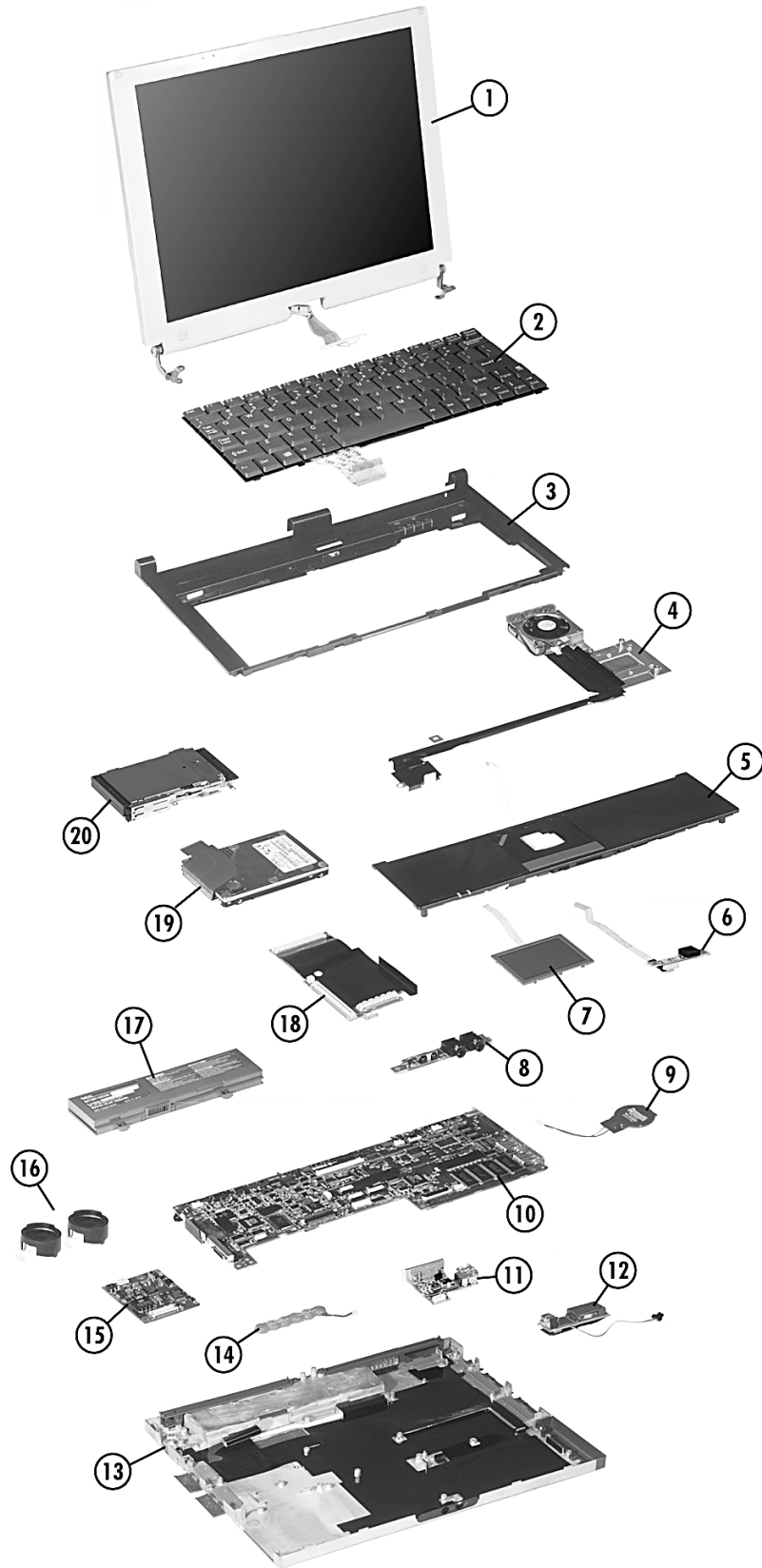

Parts List

The following table contains a listing of the field-replaceable parts and corresponding part numbers.

Field-Replaceable Parts List

Item	Description	Part Number
1	LCD Panel Sub Assembly 12.1-inch SVGA 12.1-inch XGA 10.4-inch SVGA	TBD TBD TBD
2	Keyboard	808-897405-001A
3	Top Cover Assembly	136-275492-042A
4	Fan/Heat Plate	136-648248-002A
5	Front Cover Assembly Without VersaGlide	136-275492-043A
6	LED Status Board	136-275492-006A
7	VersaGlide Assembly	136-275492-028A
8	IR/Sound Board	136-275492-005A
9	CMOS Battery	804-020804-010A
10	Main Board	136-275492-002A
11	Video/USB Board	136-275492-004A
12	Modem Cable Connector Assembly	136-275492-005A
13	Bottom Base Assembly	136-275492-045A
14	Bridge Battery	804-021205-005A
15	Modem Board	136-275492-009A
16	Speaker	808-742872-004A
17	3-Cell Battery	136-275492-034A
18	Connector Board	136-275492-003A
19	Hard Disk Drive 6-GB	136-275492-029A
20	PC Card Assembly	802-720364-2410
*	LCD Cable 12.1-inch SVGA 12.1-inch XGA 10.4-inch SVGA	136-275492-024A 136-275492-023A 136-275492-025A
*	Power Button	136-648981-002A
*	Email/Internet Button	136-648982-003A
*	VersaGlide Switch FFC	808-847603-011A
*	VersaGlide FFC	808-847603-012A
*	Left Mouse Button	136-649052-001B

Field-Replaceable Parts List

Item	Description	Part Number
*	Right Mouse Button	136-649053-001B
*	Hard Disk Drive FPC	808-879497-001A
*	LED Status Board FFC	808-847603-008A
*	Modem Board Cable	808-742873-003A
*	Memory Modules 32-MB	136-275691-035A
	64-MB	136-275492-010A
*	Diskette Drive/Parallel Port Cap	136-649740-001A
*	External Monitor Port Cap	136-649742-001A
*	USB Cap (1 Port)	136-649743-001A
*	CD-ROM Drive Cap	136-649744-002A
*	USB Cap (2-Port)	136-649744-001A
*	Memory Module Bay Cover	136-649821-001A
*	External Diskette Drive	136-275492-032A
*	External Diskette Drive Cable	808-743180-003A
*	External CD-ROM Drive	136-275492-033A
*	External CD-ROM Drive Cable	808-879628-002A
*	6-Cell Battery	136-275492-035A
*	9-Cell Battery	136-275492-701A
*	Backup Battery	804-020804-010A
*	Hinge Cover (Left)	136-649040-001B
*	Hinge Cover (Right)	136-649041-001A
*	LCD Lock Assembly	136-275492-050A
*	LCD Hook Bracket	136-649029A
*	LCD Bracket (Left 12.1-inch)	136-649003A
*	LCD Bracket (Right 12.1-inch)	136-649004A
*	Tilt Unit (Left 12.1-inch)	808-813132-001A
*	Tilt Unit (Right 12.1-inch)	808-813132-002A
*	Tilt Unit (Left 10.4-inch)	808-813132-101A
*	Tilt Unit (Right 10.4-inch)	808-813132-102A
*	LCD Cover (12.1-inch)	136-275492-051A
*	LCD Cover (10.4-inch)	136-275492-052B
*	LCD Cushion (Lateral)	136-648249-001B
*	LCD Cushion (Bottom)	136-648250-001A
*	Rubber Foot	136-648247-001A

5-4 Illustrated Parts Breakdown

Field-Replaceable Parts List

Item	Description	Part Number
*	Rubber Cap	136-649446-001A
*	Top Cover (9-Cell Battery)	136-275492-702A
*	Bottom Base (9-Cell Battery)	136-275492-703A
*	Coin Lock (9-Cell Battery)	136-649054A
*	Coin Lock Spring (9-Cell Battery)	136-649101-001A
*	Coin Lock Hook (9-Cell Battery)	136-649038-001A
*	Front Bracket (9-Cell Battery)	136-649035A
*	Connector Plate (9-Cell Battery)	136-649037A
*	Slide Piece (9-Cell Battery)	136-649058-001A
*	9-Cell Battery FPC	808-879596-001A
*	Rubber Foot (9-Cell Battery)	136-648247-001A
*	AC Adapter	808-892340-001A
*	LAN Board	136-275691-022A
*	LAN Board Cable	808-742873-101A
*	Parallel Transfer Cable	808-744220-001A
*	CD-ROM Drive AC Adapter	808-879628-003A

* Item not shown on IPB.

6

Preventive Maintenance

- Cleaning the Notebook Exterior
- Cleaning the Notebook Interior
- Protecting the Disk Drive and Diskette Drive
- Handling the Battery Pack
- Maintaining the LCD Quality

Preventive maintenance is limited to cleaning the plastic case, the keyboard, the display screen, and the diskette drive heads, as required.

Note Remove the battery and disconnect the AC adapter before performing any maintenance. Voltage is present inside the system unit and LCD even after the system is turned off.

Cleaning the Notebook Exterior

Use the steps below to clean the outer surface of the system.

1. Power off the system and remove the battery pack. Unplug all cables connected to the system.
2. Wipe the outside of the system, keyboard, and display with a soft, clean cloth. Remove stains with a damp, almost dry cloth. Use glass cleaner to clean the LCD. Apply the glass cleaner directly to the cloth and then wipe the LCD. Do not use solvents or strong, abrasive cleaners on any part of the system.
3. Clean the keys with a damp cloth. A small, soft-bristle brush may be used to clean between the keys. Make sure to use a damp cloth (not wet) to prevent moisture from seeping between the keyboard and the metal plate, possibly damaging the components under the keys. If the keyboard gets wet, thoroughly dry it before reassembling the system unit.

Cleaning the Notebook Interior

When servicing the inside of the notebook, remove dust and other foreign particles from inside the system unit as follows:

1. Remove the top cover and keyboard using the disassembly procedures discussed in the section, Disassembly and Reassembly, in Chapter 3.
2. Dust or vacuum (with a rubber-tipped nozzle) the inside of the system, particularly the main board surface. Use care to avoid damaging or dislodging any components or cables.
3. Inspect all cables connectors for damage. Ensure that connectors are seated properly before replacing the cover.

Protecting the Disk Drive and Diskette Drive

To protect the disk drive and data, back up the system disk periodically on diskettes. Periodically use a head-cleaning diskette in the disk drive to prolong the life of the drive and to help maintain data integrity.

Here are some maintenance procedures to use when servicing a hard disk:

- Always back up the data files from the hard disk.
- Run a virus detecting program to check for possible virus infected areas on the hard disk.
- Use the preinstalled ScanDisk program to correct any errors found in the directory and File Allocation Table (FAT). This also frees up space from any unused sectors.
- Never turn the computer off when the hard disk is being accessed.
- Never move or raise the computer while the hard disk is being accessed. Be especially careful not to jar the hard disk during access, this can cause a hard disk crash.

-
- Use hard disk maintenance program like DEFRAG under DOS, or acquire Norton Utilities SPEEDISK programs. These programs reorganize your hard disk by eliminating fragmentation and improve the hard disk access time.

Handling the Battery Pack

The battery pack furnished with the computer requires reasonable care and handling to ensure efficient operation and maximum life. Periodically inspect the battery terminals and the batteries for evidence of corrosion and oxide build-up.

To ensure that the battery pack endures for a normal life cycle, always observe the following precautions when handling the battery pack:

- Do not drop the battery pack or subject it to excessive shock and vibration.
- Do not expose the battery pack to direct sunlight, moisture, chemical compounds, or extreme heat.
- Do not disassemble the battery pack.
- Do not use the battery pack to power other devices.
- Do not short the battery leads or connect the battery with reversed polarity.
- Never attempt to charge the battery pack in any way other than as described in this manual and the user's guide.
- Always charge the battery pack as soon as possible after a low battery indication.

Maintaining the LCD Quality

When it comes to screen problems, heat plays a big part. After a good working session, the typical routine is to shut the machine and close the cover. The display surface (no matter what type it is) radiates heat. When you close the cover, you trap the heat against the screen. Make sure to leave the computer's cover open for about ten minutes while the heat disperses, before closing the LCD.

7

Troubleshooting

- Quick Troubleshooting
- Helpful Questions

Quick Troubleshooting

This section summarizes problems that may develop during system operation and lists suggested corrective actions.

Quick Troubleshooting

Problem	Corrective Action
No power	<p>Check that the AC adapter is plugged into the power connector of the system. Also, check that the AC adapter is plugged into a properly grounded AC power outlet.</p> <p>If using the battery as the main power source, check if the battery pack is charged and is inserted correctly.</p> <p>Replace the main board.</p>
Data on the LCD is unreadable	<p>Check the LCD Panel View Expansion in BIOS.</p> <p>Check if the installed VGA driver is correct.</p> <p>Check the VGA controller chip for any loose soldering.</p> <p>Replace the main board.</p>
Battery power does not last long	<p>Make sure that the power management features are enabled.</p> <p>Fully charge and discharge the battery pack several times to recondition it.</p> <p>Replace the battery pack.</p>
System halts during boot sequence	<p>Check the condition of the selected boot device (diskette, hard disk or CD-ROM) for bad boot track or incorrect O/S files.</p> <p>Try booting from a new bootable diskette and re-copy or repartition the hard disk.</p> <p>Check for any BIOS error messages on the display screen.</p> <p>Replace the main board.</p>
I/O processing malfunctions	<p>Check the connections of all internal and external devices.</p> <p>Replace the main board.</p>
Diskette drive does not work	<p>Check that the diskette type is correct and not faulty.</p> <p>Replace the diskette drive.</p> <p>Replace the main board.</p>

Quick Troubleshooting

Problem	Corrective Action
Hard disk drive malfunction	<p>Check if the hard disk drive is set properly on CMOS Setup.</p> <p>Check the drive connection.</p> <p>Check if the disk drive is good.</p> <p>Replace the main board.</p>
Memory malfunction	<p>Check if the memory module is inserted properly.</p> <p>Replace the memory module.</p> <p>Replace the main board.</p>
PC card does not work	<p>Check the PC card driver installation for any IRQ or I/O address conflict.</p> <p>Check if the PC card is inserted properly and all connections are set.</p> <p>If the PC card is a Type II card, install it in the system's other PC card slot.</p> <p>Replace the PC card.</p> <p>Replace the main board.</p>
NEC VersaGlide does not work	<p>Check if PS/2 or Alps mouse driver is properly installed.</p> <p>Check VersaGlide cable inside the system if it is inserted properly.</p> <p>Clean VersaGlide surface.</p> <p>Check the keyboard controller chip for any cold or loose soldering.</p> <p>Replace the main board.</p>
Parallel device does not work	<p>Check all connections.</p> <p>Check if external device is turned on.</p> <p>Check the device drive installation for any IRQ or I/O address conflict.</p> <p>Test another parallel device.</p> <p>Check the I/O controller chip for any cold or loosed soldering.</p> <p>Replace the main board.</p>

Helpful Questions

Here are some helpful questions to ask when troubleshooting the notebook:

- Is there any external power source connected to the computer?
- Is the battery fully charged?
- Is the computer turned on and the Power LED activated?
- Is the LCD display switched to the external monitor?
- Are all cables and devices connected properly and securely?
- Are all needed device drivers installed properly?
- Is the Suspend Mode activated? Press any key or slide the Power/Sleep button to the right to power on the system.

8

Getting Service and Support

- Service and Support Contact Information
- NEC CSD Web Site
- NEC CSD FTP Site
- Email/Fax to Support Services
- NEC CSD Bulletin Board
- NEC CSD Support Services
- NEC CSD Customer Assistance Center

Services and Support Contact Information

NEC CSD Services and Support

Service	Contact Information
NEC CSD Web and FTP Sites	Web address: www.nec-computers.com FTP site: ftp.neccsdeast.com
Email to NEC CSD Support Services through a commercial online service or the Internet.	Internet email address: tech-support@neccsd.com
Fax Service to NEC CSD Support Services	801-981-3133 or 801-578-5101
NEC CSD Bulletin Board System	916-379-4499
NEC CSD Support Services	U.S. and Canada: 800-632-4525
NEC CSD Customer Assistance Center	888-632-9128

Note If you purchased your computer outside of the U.S. or Canada, please contact the local NEC office or their dealers for support and service.

See the booklet, "Getting Service and Support in Asia, Australia, and Europe" to find out how to contact the local office in your country.

If you have access to a telephone, modem, and/or fax machine, you can use these services to obtain information about your system at any time, day or night, seven days a week.

Not only do these services provide information about your NEC system, they can also be used to answer your questions and help solve any problems you may have with your system, should that ever be necessary.

NEC CSD Web Site

If you have a modem or a network board, you can access the NEC CSD web site. You can do this through a commercial online service or through your Internet account. The NEC CSD web site contains general information about NEC CSD and its products, an online store, press releases, reviews, and service and support information.

Look in the Service and Support area for the following:

- technical documentation, including Frequently Asked Questions, reference manuals, and warranty information
- BIOS updates, drivers, and Setup Disk files to download
- contact information, including telephone numbers for Technical Support and links to vendor Web sites
- Click, the NEC CSD Customer Service newsletter
- an automated email form for your technical support questions
- a Reseller's area (password accessible).

To access NEC CSD's Home Page, enter the following Internet Uniform Resource Locator (URL) in your browser:

<http://www.nec-computers.com/>

NEC CSD FTP Site

You can use the Internet to access the NEC CSD FTP (file transfer protocol) site to download various files (video drivers, printer drivers, BIOS updates, and Setup Disk files). The files are essentially the same files as on the NEC CSD Web site and the NEC CSD Bulletin Board System.

To access the NEC CSD FTP site, enter the following Internet ftp address through your service:

<ftp.neccsdeast.com/>

Once in the file menu, follow the prompts to choose and download the file(s) you want.

Email/Fax to Support Services

The NEC CSD Support Services offers technical support by email over the Internet network if you have a modem. The Internet address is:

tech-support@neccsd.com

You can also fax technical questions to the NEC CSD Support Services if you have access to a fax machine or fax/modem. The fax numbers are:

(801)-981-3133 or (801)-578-5101

When using the email or fax support service, you should include the following words in the subject field for prompt response from the appropriate technical person:

- Desktop
- Monitor
- Notebook.

You should provide as much specific information about your questions as possible. Also, if you are sending a fax, please include your voice telephone number and your fax number with the question. You will receive a response to your questions within one business day.

NEC CSD Bulletin Board

If you have access to a modem, you can use the NEC CSD Bulletin Board System (BBS) to get the latest information on hardware and software. The BBS allows you to download files (video drivers, printer drivers, BIOS updates, etc.) to a diskette for system enhancements and upgrades.

Log onto the BBS as follows.

1. From the Windows desktop, click the Start button.
2. Point to Programs. Point to Accessories and then click HyperTerminal.
3. Double click the Hypertrm icon. The HyperTerminal program appears.

-
4. Follow the instructions on the screen to set up your modem. Click the HyperTerminal help button for information about dialing the phone number.

If you need to check communications settings, check that the settings match the following BBS parameters.

- Baud rate: select any baud rate that matches your modem
 - Parity: none
 - Data bits: 8
 - Stop bits: 1
 - Flow control: Xon/Xoff (select Hardware if using 14.4 bps or higher).
5. Following the HyperTerminal instructions, enter the BBS phone number (916-379-4499). Your business phone system and/or location might require a **9 1** or **1** prefix.

Note The first time that you use the BBS, you are requested to provide information for a new user questionnaire.

6. Press **Enter** twice.
7. Enter your first name, last name, and password. Press **Enter** after each.
8. Follow the screen prompts until the Main menu appears.
9. At the Main menu, select **J** to join a conference. Select **Conference 2** for the laptop and portable PC conference.
10. From the Main menu, press **F** for the a list of downloadable files. Follow the prompts to select a file for downloading.

 **CAUTION** Executable files automatically format your diskette when you download files from the BBS. Formatting destroys any data on the diskette. Before you download files from the BBS, check that you do not have information on the diskette that you need.

After you complete downloading your file, log off the BBS as follows:

1. Press **Enter** (to continue).
2. Press **G** (command for Goodbye/Hangup).
3. Press **Enter**.

NEC CSD Support Services

NEC CSD also offers direct technical support through Support Services. (NEC CSD Support Services is for U.S. and Canadian customers only; international customers should contact the local NEC office or dealer for the support and service available in your country.)

Direct assistance is available 24 hours a day, 7 days a week. Call the NEC CSD Support Services, toll free, at **1-800-632-4525** (U.S. and Canada only) for the following support.

-
- System hardware — toll-free phone support is limited to the length of the standard warranty.

For hardware support after the standard warranty, get system hardware support for a fee.

- Preinstalled software — toll-free phone support for 90 days from the time of your first call to the NEC CSD Support Services.

After the initial 90 days, get preinstalled software for a fee.

Please have available your system's name, model number, serial number, and as much information as possible about your system's problem before calling.

For outside the U.S. or Canada, please contact your local NEC office or dealer for the support and service available in your country.

NEC CSD Customer Assistance Center

NEC CSD offers Customer Service for extended warranty and contract information, spare parts ordering, warranty claims, repair services, and service authorizations.

Direct assistance is available Monday through Friday from 8:30a.m. to 8:00p.m. EST. Call the NEC CSD Customer Assistance Center, toll free, at **1-888-632-9128** (U.S. and Canada only).

9

Specifications

- System Components
- Connector Locations
- Memory Map
- Interrupt Controllers

System Components

The following system component specifications are standard except where noted.

System Processor

Intel low voltage 333-MHz CPU (not available in the U.S.)

Intel 400-MHz Pentium III CPU

Architecture

64-bit Peripheral Component Interconnect (PCI)

Random Access Memory

- Standard Main Memory
 - 64-MB SDRAM SO-DIMM
- Optional Expansion — 1 slot
 - Expandable in 32-MB, 64-MB, or 128-MB increments
 - Maximum 192 MB
- Video Ram — 2 MB SGRAM (333-MHz) or 4 MB SGRAM (400-MHz)
- Cache Memory
 - L1: KB code, 16KB data, 4 way set associate, write back (data)
 - L2: 128 K built-in (333-MHz) or 256 K built-in (400-MHz)
 - operates at full core speed
 - 4GB cacheable range

Read-Only Memory

512 KB x 8 bit, Flash ROM

Calendar Clock

Year/month/day/hour/minute/second maintained by internal back-up battery

Input/Output (I/O) Facilities

Integrated industry-standard interfaces

- FDD/Parallel — 1 port, 26-pin
 - FDD, PC8477 compatible, 16 byte FIFO, burst and non-burst modes
 - Parallel, IEEE 1284 compatible, ECP and EPP support
- CD-ROM (IDE) — 1 port, 50-pin
- Infrared — 1 port, IrDA-1 compatible
- VGA — 1 port, 15-pin high-density D-sub
- Microphone — 1 port, 3-pin, Mini Pin Jack
- Stereo Headphones — 1 port, 3-pin, Mini Pin Jack, .5 watts per channel

9-2 Specifications

-
- DC In — 1 port, for AC adapter cable
 - USB port — 3 ports, 4 pin
 - Modem — 1 port, 4-pin, RJ-11 modular jack

Speakers

Two built-in, 1 watt (W) each with a maximum 3W output

- 16-bit stereo, 48 Khz
- Sound BlasterPRO compatible
- MIDI Roland: MPU401, UART Mode compatible
- ESS Solo1 PCI AudioDrive + ESS 1946S

PC Card Slots

- Two 32-bit card slots for two Type II PC cards or one Type III PC card, 5 V or 3.3 V interface
- 32-bit CardBus support

LCD Panel

12.1-inch or high resolution active matrix Thin Film Transistor (TFT), Super Video Graphics Array (SVGA) color display

- Resolution — 800 x 600
- Colors — 16 Million, max.

Keyboard

Membrane 85 keys (both U.S. and International) with standard QWERTY-key layout (International keyboards are country-specific)

- Function keys — 12 keys
- Cursor Control keys — 8 keys; arrow keys arranged in inverted T layout
- Numeric keypad — embedded
- Fn key — function key for ROM-based key functions
- Stroke — 2.5 mm
- Height — 6 mm
- Pitch — 19 mm

External Floppy Diskette Drive

- Size — 3.5-inch
- Capacity — 1.44 MB (formatted), 2 MB (unformatted)
- Transfer Rate — 250 to 500 K/bps
- Number of tracks — 160

Hard Disk Drive

Specifications vary depending upon model:

- Ultra DMA/66 support
- Capacity — Internal 6.x or 12.x GB
- Drive height — 9.5 mm
- Read/write track-to-track seek rate — 3 ms
- Average seek time — 12 ms – 14 ms
- Revolutions per minute — 4200
- Data transfer rate
 - 16.6 MB/sec (PIO mode4/DMA mode2)
 - 66.6 MB/sec (ultra DMA mode 4)
- Media data rates — 88.0 bit/sec – 118.0 bit/sec
- Mean Time Between Errors (MTBF) — 300,000 hours

24X-speed CD-ROM Drive

- Type — 5-inch CD-ROM Pack
- Average Data Transfer Rates — 1545 KB/second to 3600 KB/second
- Burst Transfer Rate — 16.7 MB/sec, PIO mode4/DMA mode
- Average Access Time
 - 190 ms (Random)
 - 350 ms (Fullstroke)
- Interface — IDE (ATAPI)
- Photo CD Compatibility — Single Session/Multisession Photo CD, Video CD (CD-1, CD-I Ready, CD-G, CD-Plus, CD-DA, CD-EXTRN, and CD-ROM XA mode 2)

Mini-PCI LAN

- 10BASE-T and 100BASE-TX compatible
- IEEE 802.3 and IEEE 802.3u compliant
- 10/100 Mbps transmission
- 10/100M, LINK, and ACT diagnostic LEDs

56K Internal Modem

- V.90 data/V.17 fax, soft, MMX optimized
- K56flex™ compatible
- SmartDAA™ technology
- V.80 synchronous access mode

Power

AC Adapter

- Input Voltage — 100 to 240 volts (V) AC, 50 or 60 Hz, 1.5 A
- Output Voltage — 15.0 V DC, 45 Watt
- Australia, Europe and Asia use an AC power cable specific to each country's standards.

Battery Pack

- Type — three-cell Lithium Ion (Li-Ion)
- Optional Batteries — six-cell Li-Ion and nine-cell Li-Ion
- Output Voltage — 10.8 V
- Capacity — 1,550 mAH
- Recharging Time — Approximately 2.7 hours when the system is on or off.

Bridge Battery

When fully charged, backs up memory contents and system status, in Standby mode, giving you time to install a fully charged battery or connect to AC power when your battery charge becomes low.

Dimensions

- Width — 10.6 in. (269 mm)
- Depth — 8.8 in. (224.5 mm)
- Height — 0.9 in. (24.5 mm)

Weight

3.38 lb (1.54 kg) with the three-cell Lithium-Ion battery

Recommended Environment

Operation

- Temperature — 41°F to 95°F (5°C to 35°C)
- Relative Humidity — 20% to 80% (Noncondensing)

Storage

- Temperature — -4°F to 104°F (-20°C to 40°C)
- Relative Humidity — 20% to 80% (Noncondensing)

Connector Locations

The following table shows the system's connector locations.

Connector Locations	
Connector	Location
P3	Main Board
P8	Main Board
P9	Main Board
P10	Main Board
P15	Main Board
P16	Main Board
P18	Main Board
P19	Main Board
P20	Connector Board
P23	Main Board
P24	Main Board
P31	Connector Board
P32	Connector Board
P33	Connector Board
P34	Connector Board

Memory Map

The system supports system and video shadowing, both controlled through complementary metal oxide semiconductor (CMOS). The system supports BIOS as a cacheable area with write protection. The following table shows the system's memory map.

System Memory Map

Memory Space	Size	Function
0000 0000h-0009 FFFFh	640K	System/Application Memory
000A 0000h-000B FFFFh	128K	Video Buffer RAM
000C 0000h-000D FFFFh	128K	Available for applications
000E 0000h-000F FFFFh	128K	Upper ROM, System and Video BIOS
0010 0000h-09FF FFFFh	up to 160MB	Extended Memory
000A 0000h-FFEF FFFFh	128K	Video RAM Frame Buffer
FFF0 0000h-FFF7 FFFFh	512K	1 MB Extended BIOS
FFF8 0000h-FFF9 FFFFh	256K	New Extended BIOS
FFFA 0000h-FFFB FFFFh	128K	Lower ROM, Power Management BIOS
FFFE 0000h-FFFF FFFFh	128K	System BIOS (alias)

Interrupt Controllers

Using interrupts, hardware can request software services. If non-Plug and Play software is being used, the interrupt may need to be moved for software application or driver compatibility. Some interrupts cannot be moved. Fifteen interrupts can be used with a cascade connection of 8259INTC x 2. The table shows default interrupt level assignments 0 through 15, in order of decreasing priority.

System Interrupts

IRQ	Device
IRQ00	Internal Timer 1
IRQ01	Keyboard
IRQ02	PIC
IRQ03	Available/IR
IRQ04	Available/Serial
IRQ05	CardBus/Sound/Modem
IRQ06	Diskette Drive
IRQ07	LPT
IRQ08	Real-time Clock
IRQ09	Available
IRQ10	PC CardBus/LAN/Video/USB
IRQ11	Available
IRQ12	PS/2 Mouse
IRQ13	Numeric Data Processor
IRQ14	IDE Controller
IRQ15	Available

Glossary

A

applications programs

Software designed to perform specific functions, like solving business or mathematical problems.

AC Adapter

A device that connects an NEC Versa portable computer and an AC wall outlet to provide AC power for running the system or recharging the battery.

AGP

Advanced Graphics Port is an interface specification designed for the throughput demands of 3D graphics. AGP introduces a point-to-point channel allowing the graphics controller direct access to main memory, increases bandwidth to 266-MBps, and supports throughputs of 533-MBps and 1.07-GBps.

B

base RAM

Area of system memory between 0 and 640 kilobytes available to the user for operating system and application programs.

BIOS

Basic Input Output System. A collection of primitive computer routines, usually burnt into ROM, that controls the real-time clock, keyboard, disk drives, video display, and other peripheral devices.

bit

Binary digit. The smallest unit of computer data.

bits per second

(bps) A unit of transmission. Also called baud rate.

board

Printed circuit board. Board onto which computer components are soldered and thin wires are printed to connect the components.

boot

To start up a computer. See cold boot and warm boot.

bus

An electronic circuit within a computer used for transmitting data or electrical power from one device to another.

byte

Group of eight contiguous bits.

C

clock

Electronic timer used to synchronize computer operations.

CMOS

Complementary Metal Oxide Semiconductor. A chip that contains nonvolatile memory in the NEC Versa. CMOS is backed up by an internal lithium battery that preserves clock/calendar data and system configuration parameters stored in CMOS.

cold boot

Process of starting up the computer by turning on the power. If power is already on, the process means to turn off the computer and turn it on again. A cold boot reinitializes all devices.

crt

Cathode-Ray Tube. A type of display screen used in desktop monitors. It forms the screen image using tiny dots called pixels. See also LCD.

cursor

A movable image on the display screen that indicates where the next entered data appears.

D

diskette

A thin flexible platter coated with a magnetic material for storing information.

diskette drive

A magnetic drive that writes on and retrieves data from a diskette.

DSTN

Double-Scan Super-Twisted Nematic. A type of technology used in some NEC Versa LCD screen displays.

E

enhanced VGA

A video interface that offers more colors or higher resolution than VGA.

extended RAM

The area of RAM above the first megabyte of memory in the system available for enhancing system performance.

F

function key

The set of keys on the keyboard (usually F1 through F12) that let you get help and error message information or quickly select frequently used commands.

H

hard disk

A rigid magnetic storage device that provides fast access to stored data.

hardware

The electrical and mechanical parts from which a computer is made.

hertz

(Hz) A unit of frequency equal to one cycle per second.

hot key

Combination of two or three keys (such as **Ctrl-Alt-Del**) that you press simultaneously for a particular function.

I

input/output

(I/O) The process of transferring data between the computer and external devices.

IDE

Intelligent Drive Electronics. A hard disk drive type that has controller electronics built into the drive and delivers high throughput.

interface

A connection that enables two devices to communicate.

interrupt

A special control signal from an I/O device that diverts the attention of the microprocessor from the program to a special address.

K

kilobyte

(KB) 1024 bytes.

L

LAN

Local Area Network.

LCD

Liquid Crystal Display. An LCD consists of a thin sandwich of two glass plates with sealed edges, containing nematic liquid-crystal material that forms the screen image. The NEC Versa displays are LCD type.

load

To copy a program into the computer's memory from a storage device.

M

megabyte

(MB) 1,048,576 bytes.

memory

Electronic storage area in a computer that retains information and programs. A computer has two types of memory — read-only memory (ROM) and random access memory (RAM).

menu

A video display of programs or options.

microprocessor

A semiconductor central processing unit that is the principal component of a microcomputer. Usually contained on a single chip that includes an arithmetic logic unit, control logic, and control-memory unit.

mode

A method of operation; for example, the NEC Versa operates in either normal or power-saving modes.

modem

MODulator-DEModulator. A device that links computers over a telephone line.

N

nonvolatile memory

Storage media that retains its data when system power is turned off. Nonvolatile memory in the NEC Versa is a complementary metal oxide semiconductor (CMOS) chip which is backed up by an internal battery. The backup battery preserves the clock/calendar data and system configuration parameters stored in CMOS. See volatile memory.

O

operating system

Set of programs that manage the overall operation of the computer.

overwrite

Storing information at a location where information is already stored, thus destroying the original information.

P

page

A type of message transmission in which a message is sent or received via modem to a paging device from a computer (with paging communications software) or telephone.

parallel interface

Interface that communicates eight bits at a time.

parallel printer

A printer with a parallel interface.

parameter

A characteristic of a device or system.

password

A string of characters that the user must enter before the system allows access or system privileges.

PCMCIA

A credit card sized peripheral interface standard for portable devices. Types of PCMCIA cards currently offered by major vendors include fax/modems, LAN, storage cards, and wireless communications devices.

peripheral

Input or output device not under direct computer control. A printer is a peripheral device.

pixels

Picture elements. Tiny dots that make up a screen image.

port

Provides the means for an interface between the microprocessor and external devices. A cable connector is usually plugged into the port to attach the device to the computer.

processor

In a computer, a functional unit that interprets and executes instructions.

prompt

A special symbol indicating the beginning of an input line. Also a message that appears on the screen indicating that the user must take a certain action.

Q**QWERTY**

The QWERTY keyboard, designed in the 1800s for mechanical typewriters, refers to the first six keys (QWERTY) on the top row of letters on the standard keyboard.

R**RAM**

Random Access Memory. A storage device into which data is entered and from which data is retrieved in a nonsequential manner.

read

To extract data from a storage device such as a diskette.

ROM

Read-Only Memory. Memory in which stored data cannot be modified by the user except under special conditions.

reset

The process of returning a device to zero or to an initial or arbitrarily selected condition.

resolution

The degree of screen image clarity. Video display resolution is determined by the number of pixels on the screen. Resolution is usually specified in pixels by scan lines, for example, 640 by 480. See pixels.

RS-232C

Standard interface for serial devices.

S**scanner**

An optical device that reads printed material and converts it to a computer screen image.

serial interface

An interface that communicates information one bit at a time.

serial printer

A printer with a serial interface.

software

Programs that run on a computer, such as operating systems, word processors, and spreadsheets.

super video graphics array (SVGA)

A color bit-mapped graphics display standard, that provides a resolution of 1024x 768 with up to 256 colors displayed simultaneously.

system board

The main printed circuit board inside the system unit into which other boards and major chip components, such as the system microprocessor, are connected.

T**TFT**

Thin Film Transistor. A type of NEC Versa LCD color screen that supports 256 colors and provides exceptional screen display.

V**VersaGlide**

A small, touch-sensitive pad used as a pointing device on your NEC Versa notebook computer. With the VersaGlide, you can move your finger along the pad to move the cursor or simulate a mouse click by tapping the pad.

VGA

Video Graphics Array. Graphics technology that supports up to 256 K colors and a graphics resolution of 640 by 480 pixels.

volatile memory

Storage media that loses its data when system power is turned off. Standard memory and memory that you add to the NEC Versa are volatile memory. See nonvolatile memory.

W

warm boot

Process of resetting the computer without turning off the power through keyboard input (pressing **Ctrl**, **Alt**, and **Del** keys simultaneously) or the reset button. The system returns to an initial or arbitrarily selected condition.

write

To record or store information to a storage device.

Index

A

- AC adapter
 - using, 2-2
- AC power port, 1-9
- Application and driver CD
 - installing, 2-24

B

- Backup system disk, 6-2
- Battery
 - handling, 2-5
 - Maximum Life, 1-10
 - recharging precautions, 2-8
 - when to change, 2-5
- Battery bay, 1-8
- Battery charging LEDs, 1-7
- Battery pack, 1-11
 - precautions, 2-8
- Battery refresh, 2-19
- BBS, 8-3
- BIOS language setting, 2-19
- BIOS setup, 2-9
 - other options, 2-19
- Bridge battery, 1-11, 2-9
 - removal, 3-13

C

- CD-ROM port, 1-9
- Cleaning
 - internal components, 6-2
 - outer surface, 6-2
- CMOS battery, 1-11
- Connecting the AC adapter, 2-3
- Connector locations, 9-6
- Control keys, 1-7
- Cursor control keys, 1-6

D

- Dimensions
 - system, 9-5
- Dip switch settings, 3-5
- Diskette drives, 2-13

E

- Entering BIOS setup, 2-9

H

- Handling battery pack, 6-3
- Hard disk
 - removal, 3-10
- Hard disk drive, 1-11
- HDPREPEZ utility
 - using, 2-23

- Headphones, 1-8
- Height adjustment feet, 1-10

I

- Internal hard disk drive, 2-13
- IR port, 1-8, 2-18
- IR/sound board
 - removal, 3-12

K

- Kensington Lock, 1-10

L

- LCD panel controls, 1-2
- LCD panel features, 1-2
- LCD panel view expansion, 2-13
- LCD Suspend, 2-16
- LED status board
 - removal, 3-12
- Low battery power, 1-11, 2-5

M

- Main board, modem board, CMOS battery
 - removal, 3-14
- Maintaining LCD quality, 6-3
- Memory Map, 9-7
- Microphone, 1-8
- Modem ring resume, 2-16
- Monitor port, 1-8

N

- NEC CSD
 - bulletin board, 8-3
 - Customer Assistance Center, 8-5
 - email/fax, 8-3
 - FTP site, 8-3
 - support services, 8-4
 - web site, 8-2
- NEC Customize, 2-22
 - using, 2-23
- NEC utilities, 2-22
- NEC Versa disassembly sequence, 3-2
- NEC VersaGlide, 1-5
- Numeric keypad, 1-6

P

- Panel brightness, 2-16
- Parallel port, 2-18
- Parts list, 5-3
- Password
 - supervisor, 2-14
 - user, 2-14
- PC card assembly
 - removal, 3-11

Peripheral Component Interconnect (PCI), 1-2
Power button, 1-4, 2-15
Power management under AC, 2-15
Power Status LED, 1-7
Powering on, 2-3
Power-on self test (POST), 2-9

Q

Quick troubleshooting, 7-2

R

Recharging the battery, 2-5
Recommended operating environment, 9-5
Removing
 battery pack, 3-2
 bridge battery, 3-13
 hard disk, 3-10
 IR/sound board, 3-12
 keyboard, 3-6
 LED status board, 3-12
 main board, modem board, CMOS battery, 3-14
 memory module, 3-4
 PC card assembly, 3-11
 speakers, 3-14
 top cover assembly, 3-9
 VersaGlide assembly, 3-7
Replacing the battery pack, 2-6

S

Services and Support
 contact information, 8-2
Servicing the system
 required tools, 3-2
Setting boot devices, 2-17
Setting system parameters
 peripherals, 2-18
Speakers
 removal, 3-14
Specifications
 battery pack, 9-5
 bridge battery, 9-5
 calendar clock, 9-2
 CD-ROM drive, 9-4
 diskette drive, 9-3
 hard disk drive, 9-4
 input/output facilities, 9-2
 keyboard, 9-3
 Mini-PCI LAN, 9-4
 Modem, 9-4
 PC card slots, 9-3
 power, 9-5
 Random access memory, 9-2
 Read-only memory, 9-2
 speakers, 9-3
 system processor, 9-2

Supervisor password, 2-14
Suspend mode, 2-16
Suspend warning tone, 2-16
Switch settings, 3-5
System date, 2-12
System features
 front, 1-2
System switch, 2-15

T

Troubleshooting
 helpful questions, 7-4

U

USB controller, 2-18
User password, 2-14
Using the AC adapter, 2-2

W

Weight
 battery pack, 9-5
 system, 9-5

(For United States Use Only)

**Federal Communications Commission
Radio Frequency Interference Statement**

 **WARNING** Changes or modifications to this unit not expressly approved by the party responsible for compliance could void the user's authority to operate the equipment.

Note This is a Class B Digital Device. This equipment has been tested and found to comply with the limits for a Class B digital device, pursuant to Part 15 of the FCC Rules. These limits are designed to provide reasonable protection against harmful interference in a residential installation. This equipment generates, uses and can radiate radio frequency energy and, if not installed and used in accordance with the instructions, may cause harmful interference to radio communications.

However, there is no guarantee that interference will not occur in a particular installation. If this equipment does cause harmful interference to radio or television reception, which can be determined by turning the equipment off and on, the user is encouraged to try to correct the interference by one or more of the following measures.

- Reorient or relocate the receiving antenna.
- Increase the separation between the equipment and receiver.
- Connect the equipment to an outlet on a circuit different from the one to which the receiver is connected.

To meet FCC standards, shielded cables and power cords are required to connect this device to a personal computer or other Class B certified device.

Canadian Department of Communications Compliance Statement

This equipment does not exceed Class B limits per radio noise emissions or digital apparatus, set out in the Radio interference Regulation of the Canadian Department of Communications.

Avis de conformité aux normes du ministère des communications du Canada

Cet équipement ne dépasse pas les limites de Classe B d'émission de bruits radioélectriques pour les appareils numériques, telles que prescrites par le Règlement sur le brouillage radioélectrique émis par le ministère des Communications du Canada.

European Community Directive Conformance Statement

This product is in conformity with the protection requirements of EC Council Directive 89/336/EEC on the approximation of laws of the Member States relating to electro-magnetic compatibility. This product satisfied the Class B limits of EN 55022.

NEC Computer Systems Division
6000 Florin-Perkins Road
Sacramento, CA 95828-1037
All Rights Reserved

Battery Replacement

A lithium battery in some computers maintains system configuration information. In the event that the battery fails to maintain system configuration information, NEC CSD recommends that you replace the battery. For battery replacement information, call your NEC CSD dealer or the NEC CSD Customer Assistance Center.

 **WARNING** There is a danger of explosion if the battery is incorrectly replaced. Replace only with the same or equivalent type recommended by the manufacturer. Discard used batteries according to the manufacturer's instructions.

 **AVERTISSEMENT** Il y a danger d'explosion s'il y a remplacement incorrect de la batterie. Remplacer uniquement avec une batterie du même type ou d'un type recommandé par le constructeur. Mettre au rebut les batteries usagées conformément aux instructions du fabricant.

Battery Disposal

The main battery is made of Lithium-Ion (Li-Ion) and the CMOS clock battery is made of Lithium. Your bridge battery (not the main battery) is made of nickel-metal hydride (NiMH).

Contact your local waste management officials for other information regarding the environmentally sound collection, recycling, and disposal of the batteries.

NEC

NEC Computer Systems Division
6000 Florin-Perkins Road
Sacramento, CA 95828-1037
www.nec-computers.com

819-200605-000
12/99