

ThinkPad Computer Hardware Maintenance Manual

July 2005

This manual supports:

ThinkPad T43

(MT 1871/1872/1873/1874/1875/1876)

ThinkPad Dock II (MT 2877)

Note

Before using this information and the product it supports, be sure to read the general information under “Notices” on page 213.

First Edition (July 2005)

© Copyright Lenovo 2005.

Portions © Copyright International Business Machines Corporation 2005.

All rights reserved.

U.S. GOVERNMENT USERS – RESTRICTED RIGHTS:

Our products and/or services are provided with RESTRICTED RIGHTS. Use, duplication or disclosure by the Government is subject to the GSA ADP Schedule contract with Lenovo Group Limited, if any, or the standard terms of this commercial license, or if the agency is unable to accept this Program under these terms, then we provide this Program under the provisions set forth in Commercial Computer Software–Restricted Rights at FAR 52.227-19, when applicable, or under Rights in Data-General, FAR 52.227.14 (Alternate III).

Contents

About this manual	1
Introduction	3
Important service information	3
Strategy for replacing FRUs	3
Strategy for replacing a hard disk drive	4
How to use error messages	4
Strategy for replacing FRUs for CTO, CMV, and GAV	4
Product definition	4
FRU identification for CTO, CMV, and GAV products	5
Important information about replacing RoHS compliant FRUs	7
Diskette compatibility matrix	8
Safety notices: multilingual translations	8
Safety information.	20
General safety.	20
Electrical safety	21
Safety inspection guide	23
Handling devices that are sensitive to electrostatic discharge	24
Grounding requirements	25
Laser compliance statement.	26
General descriptions	29
Read this first	29
What to do first	29
Related service information	31
Service Web site	31
Restoring the pre-installed system	31
Passwords	32
Power management	35
Checkout guide	38
Testing the computer	38
Detecting system information with PC-Doctor.	41
Power system checkout	42
ThinkPad T43 Series	45
Product overview	47
Specifications	47
Status indicators	50
FRU tests	53
Fn key combinations	55
Symptom-to-FRU index	58
Numeric error codes	58
Error messages	62
Beep symptoms	64
No-beep symptoms	64
LCD-related symptoms	65
Intermittent problems	66
Undetermined problems	66

FRU replacement notices	67
Screw notices	67
Retaining serial numbers.	68
Removing and replacing a FRU.	71
1010 Battery pack (14.1-in. LCD models)	72
1020 Battery pack (15.0-in. LCD models)	74
1030 Ultrabay Slim device	75
1040 Hard disk drive	76
1050 DIMM (optional)	78
1060 Keyboard	80
1070 DIMM (standard)	84
1080 Modem daughter card (MDC-2)	85
1090 Bluetooth /Modem daughter card (BMDC-3)	87
1100 Palm rest or Palm rest with fingerprint reader (14.1-in. LCD models).	89
1110 Keyboard bezel or Keyboard bezel with fingerprint reader (15.0-in. LCD models)	92
1120 Mini PCI adapter	98
1130 Fan assembly	100
1140 Backup battery	104
1150 Speaker assembly	106
1160 Keyboard bezel (14.1-in. LCD models)	108
1170 PC Card/ExpressCard slots (14.1-in. LCD models)	110
1180 PC Card/ExpressCard slots (15.0-in. LCD models)	112
1190 LCD assembly (14.1-in. LCD models)	114
1200 LCD assembly (15.0-in. LCD models)	119
1210 CPU	124
1220 Ultrabay Slim guide rail assembly (14.1-in. LCD models)	125
1230 Ultrabay Slim guide rail assembly (15.0-in. LCD models)	127
1240 VGA and Ultrabay Slim device eject button cable	130
1250 System board and base cover (14.1-in. LCD models)	132
1260 System board, interposer card, and base cover (15.0-in. LCD models)	140
2010 LCD front bezel (14.1-in. LCD models)	148
2020 LCD front bezel (15.0-in. LCD models)	150
2030 Inverter card (14.1-in. LCD models)	152
2040 Inverter card (15.0-in. LCD models)	154
2050 Wireless antenna assemblies, LCD panel, LCD cable assembly, hinges, and LCD cover (14.1-in. LCD models)	155
2060 Wireless antenna assemblies, LCD panel, LCD cable assembly, hinges, and LCD cover (15.0-in. LCD models)	169
3010 ThinkPad Dock II PCI cover.	176
3020 ThinkPad Dock II top cover	177
Locations	180
Front view	180

Rear view	182
Bottom view	183
Parts list	184
Overall	185
14.1-in. LCD FRUs	194
15.0-in. LCD FRUs	196
Keyboard	199
Recovery CDs	203
Miscellaneous parts	205
AC adapters	208
Optional FRUs	209
Common parts list	210
Notices	213
Trademarks	215

About this manual

This manual contains service and reference information for ThinkPad® T43 series (MT 1871, 1872, 1873, 1874, 1875, and 1876), and ThinkPad Dock II (MT 2877) products. Use this manual along with the advanced diagnostic tests to troubleshoot problems.

The manual is divided into sections as follows:

- The common sections provide general information, guidelines, and safety information required in servicing computers.
- The product-specific section includes service, reference, and product-specific parts information.

Important

This manual is intended for trained service personnel who are familiar with ThinkPad products. Use this manual along with the advanced diagnostic tests to troubleshoot problems effectively.

Before servicing a ThinkPad product, be sure to review the safety information under “Safety notices: multilingual translations” on page 8, “Safety information” on page 20, and “Laser compliance statement” on page 26.

Introduction

Important service information

Important

BIOS and device driver fixes are customer-installable. The BIOS and device drivers are posted on the customer support site <http://www.lenovo.com/think/support>

Advise customers to contact the Customer Support Center at 800-426-7378 if they need assistance in obtaining or installing any diskette fixes.

Customers in Canada should call the Customer Support Center at 800-565-3344 for assistance or download information.

Strategy for replacing FRUs

Before replacing parts

Make sure that all diskette fixes are installed before replacing any FRUs listed in this manual.

Use the following strategy to prevent unnecessary expense for replacing and servicing FRUs:

- **If you are instructed to replace a FRU but the replacement does not correct the problem, reinstall the original FRU before you continue.**
- Some computers have both a processor board and a system board. If you are instructed to replace either the processor board or the system board, and replacing one of them does not correct the problem, reinstall that board, and then replace the other one.
- If an adapter or a device consists of more than one FRU, any of the FRUs may be the cause of the error. Before replacing the adapter or device, remove the FRUs, one by one, to see if the symptoms change. Replace only the FRU that changed the symptoms.

Attention: The setup configuration on the computer you are servicing may have been customized. Running Automatic Configuration may alter the settings. Note the current configuration settings (using the View Configuration option); then, when service has been completed, verify that those settings remain in effect.

Strategy for replacing a hard disk drive

Always try to run a low-level format before replacing a hard disk drive.

Attention: The drive startup sequence in the computer you are servicing may have been changed. Be extremely careful during write operations such as copying, saving, or formatting. If you select an incorrect drive, data or programs can be overwritten.

How to use error messages

Use the error codes displayed on the screen to diagnose failures. If more than one error code is displayed, begin the diagnosis with the first error code. Whatever causes the first error code may also cause false error codes. If no error code is displayed, see whether the error symptom is listed in the Symptom-to-FRU Index for the computer you are servicing.

Strategy for replacing FRUs for CTO, CMV, and GAV

Product definition

Dynamic Configure To Order (CTO)

This provides the ability for a customer to configure an IBM® solution from an eSite, and have this configuration sent to fulfillment, where it is built and shipped directly to the customer. The machine label, PC Entitlement Warehouse (PEW), eSupport, and the HMM will load these products as the 4-digit MT and 3-digit model, where model = "CTO" (Example: 1829-CTO).

Custom Model Variant (CMV)

This is a unique configuration that has been negotiated between IBM and the customer. A unique 4-digit MT and 3-digit model is provided to the customer to place orders (Example: 1829-W15). A CMV is a special bid offering. Therefore, it is NOT generally announced.

- The MTM portion of the machine label is the 4-digit MT and 3-digit model, where model = "CTO" (Example: 1829-CTO). The PRODUCT ID portion of the machine label is the 4-digit MT and 3-digit CMV model (Example: 1829-W15).
- The PEW record is the 4-digit MT and 3-digit model, where model = "CTO" (Example: 1829-CTO).
- eSupport will show both the CTO and CMV machine type models (Example: 1829-CTO and 1829-W15 will be found on the eSupport site.)

- The HMM will have the 4-digit MT and 3-digit CTO model only (Example: 1829-CTO). Again, CMVs are custom models and are not found in the HMM.

General Announce Variant (GAV)

This is a standard model (fixed configuration). GAVs are announced and offered to all customers. The MTM portion of the machine label is a 4-digit MT and 3-digit model, where model = a “fixed part number”, not “CTO” (Example: 1829-F1U). Also, PEW, eSupport, and the HMM will list these products under the same fixed model number.

FRU identification for CTO, CMV, and GAV products

There are three information resources to identify which FRUs are used to support CTO, CMV, and GAV products. These sources are PEW, eSupport, and the HMM.

Using PEW

- **PEW** is the primary source for identifying FRU part numbers and FRU descriptions for the key commodities for CTO, CMV and GAV products at a MT - serial number level. An example of key commodities are hard disk drives, system boards, microprocessors, Liquid Crystal Displays (LCDs), and memory.
- Remember, All CTO and CMV products are loaded in PEW under the 4-digit MT and 3-digit model, where model = “CTO” (Example: 1829-CTO). GAVs are loaded in PEW under the 4-digit MT and 3-digit model, where model = a “fixed part number”, not “CTO” (Example: 1829-F1U).
- PEW can be accessed at the following Web site:
<http://w3-3.ibm.com/pc/entitle>
Click on MACHINE LOOKUP, followed by WARRANTY INFORMATION. Input the MT and the Serial number and the list of key commodities will be returned in the PEW record under COMPONENT INFORMATION.
- **Business Partners** using Eclaim will access PEW when performing Entitlement Lookup. Business Partners will enter Loc ID, MT and Serial, and the key commodities will be returned in the Eclaim record under SYSTEM DETAILS.
- Authorized IBM Business Partners can access Eclaim at the following Web site: <https://wca.eclaim.com>

Using eSupport

For Key Commodities (Examples - hard disk drive, system board, microprocessor, LCD, and memory)

Important service information

- eSupport can be used to view the list of key commodities built in a particular machine serial (this is the same record found in PEW).
- eSupport can be accessed at the following Web site:
<http://www.lenovo.com/think/support>
- To view the key commodities, click on PARTS INFORMATION, then PARTS LOOKUP. Type in the model type and serial number. The key commodities will be returned in the eSupport record under PARTS SHIPPED WITH YOUR SYSTEM.

For the Remaining FRUs (the complete list of FRUs at the MT Model level)

- eSupport can be used to view the complete list of FRUs for a machine type and model.
- To view the complete list of FRUs, type in the machine type and model (Example: 1829-CTO) under QUICK PATH. Under “View by Document Type” select PARTS INFORMATION. Under “Filter by Category” select SERVICE PARTS. Under “Parts Information by Date” select SYSTEM SERVICE PARTS. The list of service parts by description, with applicable machine type model and FRU will be displayed.

Using the HMM

Use the HMM as a back-up to PEW and eSupport to view the complete list of FRUs at the MT Model level.

Important information about replacing RoHS compliant FRUs

RoHS, The Restriction of Hazardous Substances in Electrical and Electronic Equipment Directive (2002/95/EC) is a European Union legal requirement affecting the global electronics industry. RoHS requirements must be implemented on Lenovo products placed on the market after June 2006. Products on the market before June 2006 are not required to have RoHS compliant parts. So, if the original FRU parts are non compliant, replacement parts can also be non compliant. In all cases if the original FRU parts are RoHS compliant the replacement part must also be RoHS compliant.

Lenovo plans to transition to RoHS compliance well before the implementation date and expects its suppliers to be ready to support Lenovo's requirements and schedule. Products sold in 2005, will contain some RoHS compliant FRUs. The following statement pertains to these products and any product Lenovo produces containing RoHS compliant FRUs.

RoHS compliant FRUs have unique FRU part numbers. Before or after the RoHS implementation date , failed RoHS compliant parts must always be replaced using RoHS compliant FRUs, so only the FRUs identified as compliant in the system HMM or direct substitutions for those FRUs may be used.

Products marketed before June 2006		Products marketed after June 2006	
Current or original part	Replacement FRU	Current or original part	Replacement FRU
Non-RoHS	Can be Non-RoHS	Must be RoHS	Must be RoHS
Non-RoHS	Can be RoHS		
Non-RoHS	Can sub to RoHS		
RoHS	Must be RoHS		

Note: A direct substitution is a part with a different FRU part number that is automatically shipped by the distribution center at the time of the order.

Related web URLs are:

- IBM Information for Suppliers website:
<http://www-03.ibm.com/procurement/proweb.nsf/ContentDocsByTitle/United+States~Information+for+suppliers>
- RoHS Directive:
http://europa.eu.int/eur-lex/pri/en/oj/dat/2003/1_037/1_03720030213en00190023.pdf
- California Senate Bills 20, 50:
<http://www.ciwmb.ca.gov/HHW/Events/AnnualConf/2004/Presentation/MPaparian.pdf>

Diskette compatibility matrix

The compatibility of each of the drives with the diskettes for it is as follows:

Diskette drive	Diskette capacity	Compatibility
3.5-inch	1.0 MB	Read and write
	2.0 MB	Read and write
	4.0 MB	Not compatible

Safety notices: multilingual translations

In this manual, safety notices appear in English with a page number reference to the appropriate multilingual, translated safety notice found in this section.

The following safety notices are provided in English, French, German, Hebrew, Italian, and Spanish.

Safety notice 1

Before the computer is powered on after FRU replacement, make sure all screws, springs, and other small parts are in place and are not left loose inside the computer. Verify this by shaking the computer and listening for rattling sounds. Metallic parts or metal flakes can cause electrical shorts.

Avant de remettre l'ordinateur sous tension après remplacement d'une unité en clientèle, vérifiez que tous les ressorts, vis et autres pièces sont bien en place et bien fixées. Pour ce faire, secouez l'unité et assurez-vous qu'aucun bruit suspect ne se produit. Des pièces métalliques ou des copeaux de métal pourraient causer un court-circuit.

Bevor nach einem FRU-Austausch der Computer wieder angeschlossen wird, muß sichergestellt werden, daß keine Schrauben, Federn oder andere Kleinteile fehlen oder im Gehäuse vergessen wurden. Der Computer muß geschüttelt und auf Klappergeräusche geprüft werden. Metallteile oder-splitter können Kurzschlüsse erzeugen.

לפני הפעלת המחשב לאחר החלפת FRU יש לוודא שכל הברגים, הקפיצים, וחלקים קטנים אחרים נמצאים במקומם ואינם חופשיים לזוז בתוך המחשב. כדי לוודא זאת, יש לטלטל את המחשב ולהקשיב לגילוי קולות שקשוק. חלקי או שבבי מתכת עלולים לגרום לקצרים חשמליים.

Prima di accendere l'elaboratore dopo che é stata effettuata la sostituzione di una FRU, accertarsi che tutte le viti, le molle e tutte le altre parti di piccole dimensioni siano nella corretta posizione e non siano sparse all'interno dell'elaboratore. Verificare ciò scuotendo l'elaboratore e prestando attenzione ad eventuali rumori; eventuali parti o pezzetti metallici possono provocare cortocircuiti pericolosi.

Antes de encender el sistema despues de sustituir una FRU, compruebe que todos los tornillos, muelles y demás piezas pequeñas se encuentran en su sitio y no se encuentran sueltas dentro del sistema. Compruébelo agitando el sistema y escuchando los posibles ruidos que provocarían. Las piezas metálicas pueden causar cortocircuitos eléctricos.

Safety notice 2



Some standby batteries contain a small amount of nickel and cadmium. Do not disassemble a standby battery, recharge it, throw it into fire or water, or short-circuit it. Dispose of the battery as required by local ordinances or regulations. Use only the battery in the appropriate parts listing. Use of an incorrect battery can result in ignition or explosion of the battery.

Certaines batteries de secours contiennent du nickel et du cadmium. Ne les démontez pas, ne les rechargez pas, ne les exposez ni au feu ni à l'eau. Ne les mettez pas en court-circuit. Pour les mettre au rebut, conformez-vous à la réglementation en vigueur. Lorsque vous remplacez la pile de sauvegarde ou celle de l'horloge temps réel, veillez à n'utiliser que les modèles cités dans la liste de pièces détachées adéquate. Une batterie ou une pile inappropriée risque de prendre feu ou d'exploser.

Die Bereitschaftsbatterie, die sich unter dem Diskettenlaufwerk befindet, kann geringe Mengen Nickel und Cadmium enthalten. Sie darf nur durch die Verkaufsstelle oder den IBM Kundendienst ausgetauscht werden. Sie darf nicht zerlegt, wiederaufgeladen, kurzgeschlossen, oder Feuer oder Wasser ausgesetzt werden. Die Batterie kann schwere Verbrennungen oder Verätzungen verursachen. Bei der Entsorgung die örtlichen Bestimmungen für Sondermüll beachten. Beim Ersetzen der Bereitschafts- oder Systembatterie nur Batterien des Typs verwenden, der in der Ersatzteilliste aufgeführt ist. Der Einsatz falscher Batterien kann zu Entzündung oder Explosion führen.

(continued)

(continuation of safety notice 2)

סוללות המתנה מסוימות מכילות כמות קטנה של ניקל וקדמיום. אין לפרק סוללת המתנה, לטעון אותה מחדש, להשליך אותה לאש או למים או לקצר אותה. יש לסלק את הסוללה כנדרש על ידי התקנות והחוקים המקומיים. יש להשתמש רק בסוללה המופיעה ברשימת החלקים המתאימה. שימוש בסוללה לא מתאימה עלול לגרום להצתה או התפוצצות של הסוללה.

Alcune batterie di riserva contengono una piccola quantità di nichel e cadmio. Non smontarle, ricaricarle, gettarle nel fuoco o nell'acqua né cortocircuitarle. Smaltirle secondo la normativa in vigore (DPR 915/82, successive disposizioni e disposizioni locali). Quando si sostituisce la batteria dell'RTC (real time clock) o la batteria di supporto, utilizzare soltanto i tipi inseriti nell'appropriato Catalogo parti. L'impiego di una batteria non adatta potrebbe determinare l'incendio o l'esplosione della batteria stessa.

Algunas baterías de reserva contienen una pequeña cantidad de níquel y cadmio. No las desmonte, ni recargue, ni las eche al fuego o al agua ni las cortocircuite. Deséchelas tal como dispone la normativa local. Utilice sólo baterías que se encuentren en la lista de piezas. La utilización de una batería no apropiada puede provocar la ignición o explosión de la misma.

Safety notice 3



The battery pack contains small amounts of nickel. Do not disassemble it, throw it into fire or water, or short-circuit it. Dispose of the battery pack as required by local ordinances or regulations. Use only the battery in the appropriate parts listing when replacing the battery pack. Use of an incorrect battery can result in ignition or explosion of the battery.

La batterie contient du nickel. Ne la démontez pas, ne l'exposez ni au feu ni à l'eau. Ne la mettez pas en court-circuit. Pour la mettre au rebut, conformez-vous à la réglementation en vigueur. Lorsque vous remplacez la batterie, veillez à n'utiliser que les modèles cités dans la liste de pièces détachées adéquate. En effet, une batterie inappropriée risque de prendre feu ou d'exploser.

Akkus enthalten geringe Mengen von Nickel. Sie dürfen nicht zerlegt, wiederaufgeladen, kurzgeschlossen, oder Feuer oder Wasser ausgesetzt werden. Bei der Entsorgung die örtlichen Bestimmungen für Sondermüll beachten. Beim Ersetzen der Batterie nur Batterien des Typs verwenden, der in der Ersatzteilliste aufgeführt ist. Der Einsatz falscher Batterien kann zu Entzündung oder Explosion führen.

מארז הסוללה מכיל כמות קטנה של ניקל וקדמיום. אין לפרק את מארז הסוללה, להשליך אותו לאש או למים או לקצר אותו. יש לסלק את מארז הסוללה הסוללה כנדרש על ידי התקנות והחוקים המקומיים. יש להשתמש רק בסוללה המופיעה ברשימת החלקים המתאימה בזמן החלפת מארז הסוללה. שימוש בסוללה לא מתאימה עלול לגרום להצתה או התפוצצות של הסוללה.

(continued)

(continuation of safety notice 3)

La batteria contiene piccole quantità di nichel. Non smontarla, gettarla nel fuoco o nell'acqua né cortocircuitarla. Smaltirla secondo la normativa in vigore (DPR 915/82, successive disposizioni e disposizioni locali). Quando si sostituisce la batteria, utilizzare soltanto i tipi inseriti nell'appropriato Catalogo parti. L'impiego di una batteria non adatta potrebbe determinare l'incendio o l'esplosione della batteria stessa.

Las baterías contienen pequeñas cantidades de níquel. No las desmonte, ni recargue, ni las eche al fuego o al agua ni las cortocircuite. Deséchelas tal como dispone la normativa local. Utilice sólo baterías que se encuentren en la lista de piezas al sustituir la batería. La utilización de una batería no apropiada puede provocar la ignición o explosión de la misma.

Safety notice 4



The lithium battery can cause a fire, an explosion, or a severe burn. Do not recharge it, remove its polarized connector, disassemble it, heat it above 100°C (212°F), incinerate it, or expose its cell contents to water. Dispose of the battery as required by local ordinances or regulations. Use only the battery in the appropriate parts listing. Use of an incorrect battery can result in ignition or explosion of the battery.

La pile de sauvegarde contient du lithium. Elle présente des risques d'incendie, d'explosion ou de brûlures graves. Ne la rechargez pas, ne retirez pas son connecteur polarisé et ne la démontez pas. Ne l'exposez pas à une température supérieure à 100°C, ne la faites pas brûler et n'en exposez pas le contenu à l'eau. Mettez la pile au rebut conformément à la réglementation en vigueur. Une pile inappropriée risque de prendre feu ou d'exploser.

Die Systematterie ist eine Lithiumatterie. Sie kann sich entzünden, explodieren oder schwere Verbrennungen hervorrufen. Batterien dieses Typs dürfen nicht aufgeladen, zerlegt, über 100 C erhitzt oder verbrannt werden. Auch darf ihr Inhalt nicht mit Wasser in Verbindung gebracht oder der zur richtigen Polung angebrachte Verbindungsstecker entfernt werden. Bei der Entsorgung die örtlichen Bestimmungen für Sondermüll beachten. Beim Ersetzen der Batterie nur Batterien des Typs verwenden, der in der Ersatzteilliste aufgeführt ist. Der Einsatz falscher Batterien kann zu Entzündung oder Explosion führen.

(continued)

(continuation of safety notice 4)

סוללת הליתיום עלולה לגרום לשריפה, להתפוצצות או לכוויות קשות. אין לטעון אותה מחדש, לסלק את המחבר המקוטב שלה, לפרק אותה או לחמם אותה לטמפרטורה העולה על 100 מעלות צלזיוס. אין לשרוף את הסוללה ואין לחשוף את תוכן התא למים. יש לסלק את הסוללה כנדרש בתקנות ובחוקים המקומיים. יש להשתמש רק בסוללה המופיעה ברשימת החלקים המתאימים. שימוש בסוללה אחרת עלול לגרום לסכנת שריפה או התפוצצות.

La batteria di supporto e una batteria al litio e puo incendiarsi, esplodere o procurare gravi ustioni. Evitare di ricaricarla, smontarne il connettore polarizzato, smontarla, riscaldarla ad una temperatura superiore ai 100 gradi centigradi, incendiarla o gettarla in acqua. Smaltirla secondo la normativa in vigore (DPR 915/82, successive disposizioni e disposizioni locali). L'impiego di una batteria non adatta potrebbe determinare l'incendio o l'esplosione della batteria stessa.

La batería de repuesto es una batería de litio y puede provocar incendios, explosiones o quemaduras graves. No la recargue, ni quite el conector polarizado, ni la desmonte, ni caliente por encima de los 100°C (212°F), ni la incinere ni exponga el contenido de sus celdas al agua. Deséchela tal como dispone la normativa local.

Safety notice 5

If the LCD breaks and the fluid from inside the LCD gets into your eyes or on your hands, immediately wash the affected areas with water for at least 15 minutes. Seek medical care if any symptoms from the fluid are present after washing.

Si le panneau d'affichage à cristaux liquides se brise et que vous recevez dans les yeux ou sur les mains une partie du fluide, rincez-les abondamment pendant au moins quinze minutes. Consultez un médecin si des symptômes persistent après le lavage.

Die Leuchtstoffröhre im LCD-Bildschirm enthält Quecksilber. Bei der Entsorgung die örtlichen Bestimmungen für Sondermüll beachten. Der LCD-Bildschirm besteht aus Glas und kann zerbrechen, wenn er unsachgemäß behandelt wird oder der Computer auf den Boden fällt. Wenn der Bildschirm beschädigt ist und die darin befindliche Flüssigkeit in Kontakt mit Haut und Augen gerät, sollten die betroffenen Stellen mindestens 15 Minuten mit Wasser abgespült und bei Beschwerden anschließend ein Arzt aufgesucht werden.

אם מסך הגביש הנוזלי (LCD) נשבר והנוזל מתוך המסך בא במגע עם עיניכם או ידיכם, שטפו את האזורים הנגועים מיד במים במשך 15 דקות לפחות. פנו לקבלת עזרה רפואית אם תסמינים הנובעים מהמגע עם הנוזל נמשכים לאחר השטיפה.

Nel caso che caso l'LCD si dovesse rompere ed il liquido in esso contenuto entrasse in contatto con gli occhi o le mani, lavare immediatamente le parti interessate con acqua corrente per almeno 15 minuti; poi consultare un medico se i sintomi dovessero permanere.

Si la LCD se rompe y el fluido de su interior entra en contacto con sus ojos o sus manos, lave inmediatamente las áreas afectadas con agua durante 15 minutos como mínimo. Obtenga atención medica si se presenta algún síntoma del fluido despues de lavarse.

Safety notice 6



To avoid shock, do not remove the plastic cover that protects the lower part of the inverter card.

Afin d'éviter tout risque de choc électrique, ne retirez pas le cache en plastique protégeant la partie inférieure de la carte d'alimentation.

Aus Sicherheitsgründen die Kunststoffabdeckung, die den unteren Teil der Spannungswandlerplatine umgibt, nicht entfernen.

כדי למנוע התחשמלות, אין להסיר את מכסה הפלסטיק המגן על חלקו התחתון של הכרטיס ההפוך.

Per evitare scosse elettriche, non rimuovere la copertura in plastica che avvolge la parte inferiore della scheda invertitore.

Para evitar descargas, no quite la cubierta de plástico que rodea la parte baja de la tarjeta invertida.

Safety notice 7



Though the main batteries have low voltage, a shorted or grounded battery can produce enough current to burn personnel or combustible materials.

Bien que le voltage des batteries principales soit peu élevé, le court-circuit ou la mise à la masse d'une batterie peut produire suffisamment de courant pour brûler des matériaux combustibles ou causer des brûlures corporelles graves.

Obwohl Hauptbatterien eine niedrige Spannung haben, können sie doch bei Kurzschluß oder Erdung genug Strom abgeben, um brennbare Materialien zu entzünden oder Verletzungen bei Personen hervorzurufen.

אף שהסוללות הראשיות הן בעלות מתח נמוך, סוללה מקוצרת או מוארקת עלולה להפיק זרם מספיק לגרימת כוויות או להצתת חומרים דליקים.

Sebbene le batterie di alimentazione siano a basso voltaggio, una batteria in corto circuito o a massa può fornire corrente sufficiente da bruciare materiali combustibili o provocare ustioni ai tecnici di manutenzione.

Aunque las baterías principales tienen un voltaje bajo, una batería cortocircuitada o con contacto a tierra puede producir la corriente suficiente como para quemar material combustible o provocar quemaduras en el personal.

Safety notice 8



Before removing any FRU, power off the computer, unplug all power cords from electrical outlets, remove the battery pack, and then disconnect any interconnecting cables.

Avant de retirer une unité remplaçable en clientèle, mettez le système hors tension, débranchez tous les cordons d'alimentation des socles de prise de courant, retirez la batterie et déconnectez tous les cordons d'interface.

Die Stromzufuhr muß abgeschaltet, alle Stromkabel aus der Steckdose gezogen, der Akku entfernt und alle Verbindungskabel abgenommen sein, bevor eine FRU entfernt wird.

לפני סילוק FRU כלשהו, יש לכבות את המחשב, לנתק את כל כבלי החשמל משקעי החשמל, להוציא את מארז הסוללה, ואז לנתק כבלי חיבור אחרים אם יש כאלה.

Prima di rimuovere qualsiasi FRU, spegnere il sistema, scollegare dalle prese elettriche tutti i cavi di alimentazione, rimuovere la batteria e poi scollegare i cavi di interconnessione.

Antes de quitar una FRU, apague el sistema, desenchufe todos los cables de las tomas de corriente eléctrica, quite la batería y, a continuación, desconecte cualquier cable de conexión entre dispositivos.

Safety information

The following section presents safety information with which you need to be familiar before you service a ThinkPad computer.

General safety

Follow these rules to ensure general safety:

- Observe good housekeeping in the area of the machines during and after maintenance.
- When lifting any heavy object:
 1. Make sure that you can stand safely without slipping.
 2. Distribute the weight of the object equally between your feet.
 3. Use a slow lifting force. Never move suddenly or twist when you attempt to lift.
 4. Lift by standing or by pushing up with your leg muscles; this action removes the strain from the muscles in your back. *Do not attempt to lift any object that weighs more than 16 kg (35 lb) or that you think is too heavy for you.*
- Do not perform any action that causes hazards to the customer, or that makes the equipment unsafe.
- Before you start the machine, make sure that other service representatives and the customer's personnel are not in a hazardous position.
- Place removed covers and other parts in a safe place, away from all personnel, while you are servicing the machine.
- Keep your toolbox away from walk areas so that other people will not trip over it.
- Do not wear loose clothing that can be trapped in the moving parts of a machine. Make sure that your sleeves are fastened or rolled up above your elbows. If your hair is long, fasten it.
- Insert the ends of your necktie or scarf inside clothing or fasten it with a nonconductive clip, about 8 centimeters (3 inches) from the end.
- Do not wear jewelry, chains, metal-frame eyeglasses, or metal fasteners for your clothing.

Attention: Metal objects are good electrical conductors.
- Wear safety glasses when you are hammering, drilling, soldering, cutting wire, attaching springs, using solvents, or working in any other conditions that might be hazardous to your eyes.

- After service, reinstall all safety shields, guards, labels, and ground wires. Replace any safety device that is worn or defective.
- Reinstall all covers correctly before returning the machine to the customer.
- Fan louvers on the machine help to prevent overheating of internal components. Do not obstruct fan louvers or cover them with labels or stickers.

WARNING

Handling the cord on this product or cords associated with accessories sold with this product will expose you to lead, a chemical known to the State of California to cause cancer, and birth defects or other reproductive harm. ***Wash hands after handling.***

Electrical safety

Observe the following rules when working on electrical equipment.

Important

Use only approved tools and test equipment. Some hand tools have handles covered with a soft material that does not insulate you when working with live electrical currents.

Many customers have, near their equipment, rubber floor mats that contain small conductive fibers to decrease electrostatic discharges. Do not use this type of mat to protect yourself from electrical shock.

- Find the room emergency power-off (EPO) switch, disconnecting switch, or electrical outlet. If an electrical accident occurs, you can then operate the switch or unplug the power cord quickly.
- Do not work alone under hazardous conditions or near equipment that has hazardous voltages.
- Disconnect all power before:
 - Performing a mechanical inspection
 - Working near power supplies
 - Removing or installing main units
- Before you start to work on the machine, unplug the power cord. If you cannot unplug it, ask the customer to power-off the wall box that supplies power to the machine, and to lock the wall box in the off position.
- If you need to work on a machine that has *exposed* electrical circuits, observe the following precautions:

Safety information

- Ensure that another person, familiar with the power-off controls, is near you.

Attention: Another person must be there to switch off the power, if necessary.

- Use only one hand when working with powered-on electrical equipment; keep the other hand in your pocket or behind your back.

Attention: An electrical shock can occur only when there is a complete circuit. By observing the above rule, you may prevent a current from passing through your body.

- When using testers, set the controls correctly and use the approved probe leads and accessories for that tester.
- Stand on suitable rubber mats (obtained locally, if necessary) to insulate you from grounds such as metal floor strips and machine frames.

Observe the special safety precautions when you work with very high voltages; Instructions for these precautions are in the safety sections of maintenance information. Use extreme care when measuring high voltages.

- Regularly inspect and maintain your electrical hand tools for safe operational condition.
- Do not use worn or broken tools and testers.
- *Never assume* that power has been disconnected from a circuit. First, *check* that it has been powered off.
- Always look carefully for possible hazards in your work area. Examples of these hazards are moist floors, nongrounded power extension cables, power surges, and missing safety grounds.
- Do not touch live electrical circuits with the reflective surface of a plastic dental mirror. The surface is conductive; such touching can cause personal injury and machine damage.
- Do not service the following parts *with the power on* when they are removed from their normal operating places in a machine:
 - Power supply units
 - Pumps
 - Blowers and fans
 - Motor generators

and similar units. (This practice ensures correct grounding of the units.)

- If an electrical accident occurs:
 - Use caution; do not become a victim yourself.
 - Switch off power.
 - Send another person to get medical aid.

Safety inspection guide

The purpose of this inspection guide is to assist you in identifying potentially unsafe conditions. As each machine was designed and built, required safety items were installed to protect users and service personnel from injury. This guide addresses only those items. You should use good judgment to identify potential safety hazards due to attachment of non-ThinkPad features or options not covered by this inspection guide.

If any unsafe conditions are present, you must determine how serious the apparent hazard could be and whether you can continue without first correcting the problem.

Consider these conditions and the safety hazards they present:

- Electrical hazards, especially primary power (primary voltage on the frame can cause serious or fatal electrical shock)
- Explosive hazards, such as a damaged CRT face or a bulging capacitor
- Mechanical hazards, such as loose or missing hardware

To determine whether there are any potentially unsafe conditions, use the following checklist at the beginning of every service task. Begin the checks with the power off, and the power cord disconnected.

Checklist:

1. Check exterior covers for damage (loose, broken, or sharp edges).
2. Power off the computer. Disconnect the power cord.
3. Check the power cord for:
 - a. A third-wire ground connector in good condition. Use a meter to measure third-wire ground continuity for 0.1 ohm or less between the external ground pin and the frame ground.
 - b. The power cord should be the type specified in the parts list.
 - c. Insulation must not be frayed or worn.
4. Remove the cover.
5. Check for any obvious non-ThinkPad alterations. Use good judgment as to the safety of any non-ThinkPad alterations.
6. Check inside the unit for any obvious unsafe conditions, such as metal filings, contamination, water or other liquids, or signs of fire or smoke damage.
7. Check for worn, frayed, or pinched cables.

8. Check that the power-supply cover fasteners (screws or rivets) have not been removed or tampered with.

Handling devices that are sensitive to electrostatic discharge

Any computer part containing transistors or integrated circuits (ICs) should be considered sensitive to electrostatic discharge (ESD.) ESD damage can occur when there is a difference in charge between objects. Protect against ESD damage by equalizing the charge so that the machine, the part, the work mat, and the person handling the part are all at the same charge.

Notes

1. Use product-specific ESD procedures when they exceed the requirements noted here.
2. Make sure that the ESD protective devices you use have been certified (ISO 9000) as fully effective.

When handling ESD-sensitive parts:

- Keep the parts in protective packages until they are inserted into the product.
- Avoid contact with other people.
- Wear a grounded wrist strap against your skin to eliminate static on your body.
- Prevent the part from touching your clothing. Most clothing is insulative and retains a charge even when you are wearing a wrist strap.
- Use the black side of a grounded work mat to provide a static-free work surface. The mat is especially useful when handling ESD-sensitive devices.
- Select a grounding system, such as those listed below, to provide protection that meets the specific service requirement.

Note

The use of a grounding system to guard against ESD damage is desirable but not necessary.

- Attach the ESD ground clip to any frame ground, ground braid, or green-wire ground.
- When working on a double-insulated or battery-operated system, use an ESD common ground or reference point. You can use coax or connector-outside shells on these systems.

- Use the round ground prong of the ac plug on ac-operated computers.

Grounding requirements

Electrical grounding of the computer is required for operator safety and correct system function. Proper grounding of the electrical outlet can be verified by a certified electrician.

Laser compliance statement

Some models of ThinkPad computer are equipped from the factory with an optical storage device such as a CD-ROM drive or a DVD-ROM drive. Such devices are also sold separately as options. If one of these drives is installed, it is certified in the U.S. to conform to the requirements of the Department of Health and Human Services 21 Code of Federal Regulations (DHHS 21 CFR) Subchapter J for Class 1 laser products. Elsewhere, the drive is certified to conform to the requirements of the International Electrotechnical Commission (IEC) 825 and CENELEC EN 60 825 for Class 1 laser products.

If a CD-ROM drive, a DVD-ROM drive, or another laser device is installed, note the following:

⚠ CAUTION:

Use of controls or adjustments or performance of procedures other than those specified herein might result in hazardous radiation exposure.

O uso de controles, ajustes ou desempenho de procedimentos diferentes daqueles aqui especificados pode resultar em perigosa exposição à radiação.

凡未在这里指明的任何控制用法、调整、行为，都会导致严重后果。

Pour éviter tout risque d'exposition au rayon laser, respectez les consignes de réglage et d'utilisation des commandes, ainsi que les procédures décrites.

Werden Steuer- und Einstellelemente anders als hier festgesetzt verwendet, kann gefährliche Laserstrahlung auftreten.

Az itt előírt eljárásoktól, beállításoktól és vezérlésektől eltérni a lézersugárzás veszélye miatt kockázatos !

L'utilizzo di controlli, regolazioni o l'esecuzione di procedure diverse da quelle specificate possono provocare l'esposizione a.

Использование элементов настройки и выполнение процедур иных, чем указано здесь, может привести к опасному радиационному облучению.

Použitie kontrôl, úprav alebo iných vykonaní od iných výrobcov, ako je v tomto špecifikované, mohlo by mať za následok nebezpečenstvo vystavenia sa vyžiarovaniu.

El uso de controles o ajustes o la ejecución de procedimientos distintos de los aquí especificados puede provocar la exposición a radiaciones peligrosas.

Opening the CD-ROM drive, the DVD-ROM drive, or any other optical storage device could result in exposure to hazardous laser radiation. There are no serviceable parts inside those drives. **Do not open.**

A CD-ROM drive, a DVD-ROM drive, or any other storage device installed may contain an embedded Class 3A or Class 3B laser diode. Note the following:

⚠ DANGER

Emits visible and invisible laser radiation when open. Do not stare into the beam, do not view directly with optical instruments, and avoid direct exposure to the beam.

Radiação por raio laser ao abrir. Não olhe fixo no feixe de luz, não olhe diretamente por meio de instrumentos óticos e evite exposição direta com o feixe de luz.

开启时会有激光发射时，请勿盯视激光光束，请勿直接查看视觉仪器，并且避免直接接触在激光光束之中。

Rayonnement laser si carter ouvert. Évitez de fixer le faisceau, de le regarder directement avec des instruments optiques, ou de vous exposer au rayon.

Laserstrahlung bei geöffnetem Gerät. Nicht direkt oder über optische Instrumente in den Laserstrahl sehen und den Strahlungsbereich meiden.

Kinyitáskor lézersugár ! Ne nézzen bele se szabad szemmel, se optikai eszközökkel. Kerülje a sugárnyalábbal való érintkezést !.

Aperto l'unità vengono emesse radiazioni laser. Non fissare il fascio, non guardarlo direttamente con strumenti ottici e evitare l'esposizione diretta al fascio.

Открывая, берегитесь лазерного излучения. Не смотрите на луч, не разглядывайте его с помощью оптических инструментов, а также избегайте прямого воздействия лазерного луча.

Keď je laserová jednotka otvorená. Vyhnite sa priamemu pohľadu a nehladte priamo s optickými nástrojmi do lúča a vyhnite sa priamemu vystaveniu lúčov.

Radiación láser al abrir. No mire fijamente ni examine con instrumental óptico el haz de luz. Evite la exposición directa al haz.

General descriptions

The descriptions in this chapter apply to any ThinkPad model that has the PC-Doctor® for DOS diagnostics program. Some descriptions might not apply to your particular computer.

Read this first

Before you go to the checkout guide, be sure to read this section.

Important notes

- **Only certified trained personnel should service the computer.**
- **Before replacing any FRU, read the entire page on removing and replacing FRUs.**
- **When you replace FRUs, use new nylon-coated screws.**
- **Be extremely careful during such write operations as copying, saving, or formatting.** Drives in the computer that you are servicing sequence might have been altered. If you select an incorrect drive, data or programs might be overwritten.
- **Replace an FRU only with another FRU of the correct model.** When you replace a FRU, make sure that the model of the machine and the FRU part number are correct by referring to the FRU parts list.
- **A FRU should not be replaced because of a single, unreproducible failure.** Single failures can occur for a variety of reasons that have nothing to do with a hardware defect, such as cosmic radiation, electrostatic discharge, or software errors. Consider replacing a FRU only when a problem recurs. If you suspect that a FRU is defective, clear the error log and run the test again. If the error does not recur, do not replace the FRU.
- **Be careful not to replace a nondefective FRU.**

What to do first

When you do return a FRU, you must include the following information in the parts exchange form or parts return form that you attach to it:

- ___ 1. Name and phone number of servicer

Read this first

- ___ 2. Date of service
- ___ 3. Date on which the machine failed
- ___ 4. Date of purchase
- ___ 5. Failure symptoms, error codes appearing on the display, and beep symptoms
- ___ 6. Procedure index and page number in which the failing FRU was detected
- ___ 7. Failing FRU name and part number
- ___ 8. Machine type, model number, and serial number
- ___ 9. Customer's name and address

Note for warranty:

During the warranty period, the customer may be responsible for repair costs if the computer damage was caused by misuse, accident, modification, unsuitable physical or operating environment, or improper maintenance by the customer. Following is a list of some common items that are not covered under warranty and some symptoms that might indicate that the system was subjected to stress beyond normal use.

Before checking problems with the computer, determine whether the damage is covered under the warranty by referring to the following list:

The following are not covered under warranty:

- LCD panel cracked from the application of excessive force or from being dropped
- Scratched (cosmetic) parts
- Distortion, deformation, or discoloration of the cosmetic parts
- Plastic parts, latches, pins, or connectors that have been cracked or broken by excessive force
- Damage caused by liquid spilled into the system
- Damage caused by the improper insertion of a PC Card or the installation of an incompatible card
- Diskette drive damage caused by pressure on the diskette drive cover, foreign material in the drive, or the insertion of a diskette with multiple labels
- Damaged or bent diskette eject button
- Fuses blown by attachment of a nonsupported device
- Forgotten computer password (making the computer unusable)
- Sticky keys caused by spilling a liquid onto the keyboard

The following symptoms might indicate damage caused by nonwarranted activities:

- Missing parts might be a symptom of unauthorized service or modification.
- If the spindle of a hard disk drive becomes noisy, it may have been subjected to excessive force, or dropped.

Related service information

This section provides information about the following:

- “Service Web site”
- “Restoring the pre-installed system”
- “Passwords” on page 32
- “Power management” on page 35

Service Web site

When the latest maintenance diskette and the system program service diskette become available, they will be posted on <http://www.lenovo.com/think/spm>

Restoring the pre-installed system

When the hard disk drive is replaced because of a failure, no Product Recovery program is on the new hard disk. In this case, you must use the recovery CD for the computer. Order the recovery CD and the hard disk drive at the same time so that you can recover the new hard disk drive with the pre-installed software when they arrive. For information on which CD to order, see “Recovery CDs” on page 203.

Recovery to Factory Contents by using Product Recovery CDs

To create the service partition and install the factory contents from the recovery CD, do the following:

Note

The recovery process might take up to 2 hours.
--

1. Insert the recovery CD into the CD or DVD drive, then restart the computer.
2. The following message is displayed: **“Your computer originally included a Product Recovery program ... Reinstall the Product Recovery program? (Y/N) []”**.
3. Press the Y key. The service partition is created and loaded with the Product Recovery program files.
4. At next window, press Enter to continue.
 - The service partition is created. The system automatically reboots during this process.
 - The recovery process copies some files to the service partition, and PKUNZIPs others.
 - Follow the prompts. You may be prompted to change CDs.
 - When the process is complete, the system reboots.

Related service information

5. If you get a message asking which operating system to install, select the proper operating system and press Enter.
6. A message is displayed: “**Full Recovery:**”. Press Enter to select.
7. On each of the next three windows, press the Y key.
8. Follow the prompts to complete the recovery.

Passwords

As many as three passwords may be needed for any ThinkPad computer: the power-on password (POP), the hard-disk password (HDP), and the supervisor password (SVP).

If any of these passwords has been set, a prompt for it appears on the screen whenever the computer is turned on. The computer does not start until the password is entered.

Exception: If only an SVP is installed, the password prompt does not appear when the operating system is booted.

Power-on password:

A power-on password (POP) protects the system from being powered on by an unauthorized person. The password must be entered before an operating system can be booted.

Hard-disk password:

There are two hard-disk passwords (HDPs):

- User HDP—for the user
- Master HDP—for the system administrator, who can use it to get access to the hard disk even if the user has changed the user HDP

Note: There are two modes for the HDP: **User only** and **Master + User**. The **Master + User** mode requires two HDPs; the system administrator enters both in the same operation. The system administrator then provides the user HDP to the system user.

Attention: If the user HDP has been forgotten, check whether a master HDP has been set. If it has, it can be used for access to the hard disk drive. If no master HDP is available, neither Lenovo nor Lenovo authorized servicers provide any services to reset either the user or the master HDP, or to recover data from the hard disk drive. The hard disk drive can be replaced for a scheduled fee.

Supervisor password:

A supervisor password (SVP) protects the system

information stored in the BIOS Setup Utility. The user must enter the SVP in order to get access to the BIOS Setup Utility and change the system configuration.

Attention: If the SVP has been forgotten and cannot be made available to the servicer, there is no service procedure to reset the password. The system board must be replaced for a scheduled fee.

How to remove the power-on password

To remove a POP that you have forgotten, do the following:

(A) If no SVP has been set:

1. Turn off the computer.
2. Remove the battery pack.

For how to remove the battery pack, see “1010 Battery pack (14.1-in. LCD models)” on page 72.

3. Remove the backup battery.

For how to remove the backup battery, see “1140 Backup battery” on page 104.

4. Turn on the computer and wait until the POST ends.

After the POST ends, the password prompt does not appear. The POP has been removed.

5. Reinstall the backup battery and the battery pack.

(B) If an SVP has been set and is known by the servicer:

1. Turn on the computer; then, while the “To interrupt normal startup, press the blue Access IBM button” message is displayed at the lower-left of the screen, press the Access IBM button. The Rescue and Recovery screen opens.

For models supporting the Passphrase function, press F1 while the POP icon is appearing on the screen; then enter the POP. For the other models, enter the POP.

Note: To check whether the ThinkPad computer supports the Passphrase function, enter the BIOS Setup Utility and go to **Security --> Password**. If the **Using Passphrase** item is displayed in the menu, this function is available on the ThinkPad computer.

2. Click **Access BIOS**. The system Restart Required window is displayed.
3. Click **Yes**. The computer restarts, and the BIOS Setup Utility screen opens.
4. Select **Security**, using the cursor directional keys to move down the menu.

5. Select **Password**.
6. Select **Power-On Password**.
7. Type the current SVP in the **Enter Current Password** field. then leave the **Enter New Password** field blank, and press Enter twice.
8. In the Changes have been saved window, press Enter.
9. Press F10; then, in the Setup confirmation window, select **Yes** .

How to remove the hard-disk password

Attention: If **User only** mode is selected and the user HDP has been forgotten and cannot be made available to the servicer, neither Lenovo nor Lenovo authorized servicers provide any services to reset the user HDPs or to recover data from the hard disk drive. The hard disk drive can be replaced for a scheduled fee.

To remove a user HDP that has been forgotten, when the SVP and the master HDP are known, do the following:

1. Turn on the computer; then, while the “To interrupt normal startup, press the blue Access IBM button” message is displayed at the lower-left of the screen, press the Access IBM button. The Rescue and Recovery screen opens.

For models supporting the Passphrase function, press F1 while HDP icon is appearing on the screen; then enter the master HDP. For the other models, enter the master HDP.

Note: To check whether the ThinkPad computer supports the Passphrase function, enter the BIOS Setup Utility and go to **Security --> Password**. If **Using Passphrase** item is displayed in the menu, this function is available on the ThinkPad computer.

2. Click **Access BIOS**. The system Restart Required window is displayed.
3. Click **Yes**. The computer restarts, and the BIOS Setup Utility screen opens.
4. Select **Security**, using the cursor directional keys to move down the menu.
5. Select **Password**.
6. Select **Hard-disk x password**, where x is the letter of the hard disk drive. A pop-up window opens.
7. Select **Master HDP**.
8. Type the current master HDP in the **Enter Current Password** field. then leave the **Enter New Password** field blank, and press Enter twice.
9. Press F10.

10. Select **Yes** in the Setup Configuration window.
Both user HDP and master HDP will have been removed.

Power management

To reduce power consumption, the computer has three power management modes: screen blank, standby, and hibernation.

Screen blank mode

Screen blank mode has three variants, as follows:

1. If you press Fn+F3, or if the time set on the “LCD off timer” in the BIOS Setup Utility expires,
 - The LCD backlight turns off.
 - The hard disk drive motor stops.
 - The speaker is muted.
2. If you are using the ACPI operating system and you press Fn+F3,
 - The LCD backlight turns off.
 - The hard disk drive motor stops.
3. If the time set on the “Turn off monitor” timer in the operating system expires,
 - The LCD backlight turns off.

To end screen blank mode and resume normal operation, press any key.

Standby mode

When the computer enters standby mode, the following events occur in addition to what occurs in screen blank mode:

- The LCD is powered off.
- The hard disk drive is powered off.
- The CPU stops.

To enter standby mode, press Fn+F4.

Note: If you are using the ACPI operating system, you can change the action of Fn+F4.

In certain circumstances, the computer goes into standby mode automatically:

- If a “suspend time” has been set on the timer, and the user does not do any operation with the keyboard, the TrackPoint[®], the hard disk, the parallel connector, or the diskette drive within that time.
- If the battery indicator blinks orange, indicating that the battery power is low. (Alternatively, if **Hibernate when battery becomes low** has been selected in the “Power Management Properties” window, the computer goes into hibernation mode.)

Note for the APM operating system:

Even if you do not set the low-battery alarm, the charge indicator notifies you when the battery is low, and then the computer enters the power-saving mode automatically. This default low-battery behavior is independent of the operating system; so if you have set the low-battery alarm, the computer may not do what you specified. It chooses either your setting or the default setting, whichever is appropriate.

If you are using the ACPI operating system, only the low-battery alarm is available.

To cause the computer to return from standby mode and resume operation, do one of the following:

- Press the Fn key.
- Open the LCD cover.
- Turn on the power switch.

Also, in either of the following events, the computer automatically returns from standby mode and resumes operation:

- The ring indicator (RI) is signaled by a serial device or a PC Card device.
- The time set on the resume timer elapses.

Note: The computer does not accept any input immediately after it enters standby mode. Wait a few seconds before taking any action to reenter operation mode.

Hibernation mode

Note for OS/2

If you are using OS/2 in the default format, HPFS, you cannot create a hibernation file. If you want to use hibernation mode, you will need to reinstall OS/2 with FAT format.

In hibernation mode, the following occurs:

- The system status, RAM, VRAM, and setup data are stored on the hard disk.
- The system is powered off.

Note: If the computer enters the hibernation mode while it is docked to the docking station, do not undock it before resuming normal operation. If you do undock it and then try to resume normal operation, you will get an error message, and you will have to restart the system.

To cause the computer to enter hibernation mode, do any of the following:

- Press the Fn+F12 keys.
- If you are using the APM operating system and have set the mode to **Power switch mode [Hibernation]**, turn off the power switch.
- If you are using the ACPI operating system and have defined one of the following actions as the event that causes the system to go into hibernation mode, perform that action.
 - Closing the lid.
 - Pressing the power button.
 - Pressing Fn+F4 keys.

Also, the computer goes into hibernation mode automatically in either of the following conditions:

- If a “hibernation time” has been set on the timer, and if the user does not do any operation with the keyboard, the TrackPoint, the hard disk drive, the parallel connector, or the diskette drive within that time.
- If the timer conditions are satisfied in suspend mode.
- If you are using the APM operating system and have set the mode to **Hibernate when battery becomes low**, and the battery charge becomes critically low.

When the power is turned on, the computer returns from hibernation mode and resumes operation. The hibernation file in the boot record on the hard disk drive is read, and system status is restored from the hard disk drive.

Checkout guide

Use the following procedures as a guide in identifying and correcting problems with the ThinkPad computer.

Note: The diagnostic tests are intended to test only ThinkPad products. The use of non-ThinkPad products, prototype cards, or modified options can lead to false indications of errors and invalid system responses.

1. Identify the failing symptoms in as much detail as possible.
2. Verify the symptoms. Try to re-create the failure by running the diagnostic test or by repeating the operation.

Testing the computer

The ThinkPad computer has a test program called PC-Doctor for DOS (hereafter called *PC-Doctor*.) You can detect errors by running the diagnostics test included in PC-Doctor. This section is an overview of the procedure. For details that depend on model-unique functions, refer to “Product overview” on page 47.

For some possible configurations of the computer, PC-Doctor might not run correctly. To avoid this problem, you need to initialize the computer setup by use of the BIOS Setup Utility before you run PC-Doctor. On the BIOS Setup Utility screen, press F9, Enter, F10, and then Enter.

Note: When you initialize the computer configuration, some devices are disabled, such as the serial port. If you test one of these devices, you will need to enable it by using Configuration utility for DOS. The utility is available on the following Web site:
<http://www.lenovo.com/think/support>

PC-Doctor cannot be used to test a device that is in the docking station, even if the computer supports the docking station. To test a USB device, connect it to the USB connector of the computer.

Creating the PC-Doctor diagnostics diskette

To create the PC-Doctor disk from the Rescue and Recovery workspace, do as follows:

1. Enter the Rescue and Recovery workspace by pressing the Access IBM button during POST.
2. When the Rescue and Recovery workspace finishes loading, click **Diagnostic Diskette**.

3. Authenticating the digital signature takes about 15 seconds; then the ThinkPad computer will reboot into PC-DOS.
4. A batch file automatically starts up to prompt you through the process of creating diskettes. You are notified of how many diskettes you will need.
 - a. You are prompted to insert each diskette in sequence.
 - b. Typically, all you need to do is to press the Enter key for the floppy drive; the system then formats and creates the diskette.
 - c. Each diskette is erased and formatted with the PC-Doctor for DOS boot image.
5. Once all the diskettes have been created, the ThinkPad computer will reboot. The user is asked to remove all diskettes from the drive, or to insert the first diskette created if it is desired to run the diagnostics.

To run the test, do as follows:

Note: In the following procedure, you can select an item not only with the arrow keys, but also with the TrackPoint pointer. Instead of pressing Enter, click the left button.

1. Insert the PC-Doctor disk into the diskette drive; then power on the computer.

If the computer cannot be powered on, go to “Power system checkout” on page 42, and check the power sources.

If an error code appears, go to “Symptom-to-FRU index” on page 58.

On the first screen, select the model and press Enter. Follow the instructions on the screen.

2. The main panel of PC-Doctor appears.
3. Select **Diagnostics** with the arrow keys, and press Enter.

A pull-down menu appears. (Its exact form depends on the model.)

Note: PC-Doctor menu does not mean the formal support device list. Some unsupported device names may appear in the PC-Doctor menu.

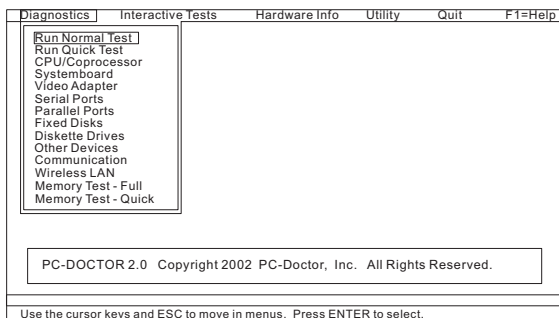

The options on the test menu are as follows:

Diagnostics	Interactive Tests
<ul style="list-style-type: none"> • Run Normal Test • Run Quick Test • CPU/Coprocessor • Systemboard • Video Adapter • Serial Ports • Parallel Ports • Fixed Disks • Diskette Drives • Other Devices • ThinkPad Devices • Communication • Wireless LAN • Memory Test – Full • Memory Test – Quick 	<ul style="list-style-type: none"> • Keyboard • Video • Internal Speaker • Mouse • Diskette • System Load • CD-ROM/DVD Test • Intel Wireless Radio
<p>Notes:</p> <ul style="list-style-type: none"> • In the Keyboard test in Interactive Tests, the Fn key should be held down for at least 2 seconds; otherwise, it cannot be sensed. • Video Adapter test supports only the LCD display on the ThinkPad computer. If you have an external monitor attached to your computer, detach it before running PC-Doctor for DOS. • When Legacy Floppy Drives is enabled in the BIOS Setup Utility, the Diskette Drives test is activated even if no legacy diskette drive is attached to the ThinkPad computer. 	

4. Run the applicable function test.
5. Follow the instructions on the screen. If there is a problem, PC-Doctor shows messages describing it.
6. To exit the test, select **Quit — Exit Diag**.

To cancel the test, press Esc.

Note: After running PC-Doctor, check the time and date on the system and reset them if they are incorrect.

Detecting system information with PC-Doctor

PC-Doctor can detect the following system information:

Hardware Info

- System Configuration
- Memory Contents
- Physical Disk Drives
- Logical Disk Drives
- VGA Information
- IDE Drive Info
- PCI Information
- PNPISA Info
- SMBIOS Info
- VESA LCD Info
- Hardware Events Log

Utility

- Run External Tests
- Surface Scan Hard Disk
- Benchmark System
- DOS Shell
- Tech Support Form
- Battery Rundown
- View Test Log
- Print Log
- Save Log
- Full Erase Hard Drive
- Quick Erase Hard Drive

Power system checkout

To verify a symptom, do the following:

1. Turn off the computer.
2. Remove the battery pack.
3. Connect the ac adapter.
4. Check that power is supplied when you turn on the computer.
5. Turn off the computer.
6. Disconnect the ac adapter and install the charged battery pack.
7. Check that the battery pack supplies power when you turn on the computer.

If you suspect a power problem, see the appropriate one of the following power supply checkouts:

- “Checking the ac adapter”
- “Checking operational charging” on page 43
- “Checking the battery pack” on page 43
- “Checking the backup battery” on page 44

Checking the ac adapter

You are here because the computer fails only when the ac adapter is used.

- If the power problem occurs only when the port replicator is used, replace the port replicator.
- If the power-on indicator does not turn on, check the power cord of the ac adapter for correct continuity and installation.
- If the computer does not charge during operation, go to “Checking operational charging.”

To check the ac adapter, do the following:

1. Unplug the ac adapter cable from the computer.
2. Measure the output voltage at the plug of the ac adapter cable. See the following figure:

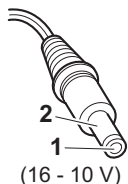

Pin	Voltage (V dc)
1	+15.5 to +17.0
2	Ground

3. If the voltage is not correct, replace the ac adapter.
4. If the voltage is acceptable, do the following:
 - Replace the system board.
 - If the problem persists, go to “Product overview” on page 47.

Note: Noise from the ac adapter does not always indicate a defect.

Checking operational charging

To check whether the battery charges properly during operation, use a discharged battery pack or a battery pack that has less than 50% of the total power remaining when installed in the computer.

Perform operational charging. If the battery status indicator or icon does not turn on, remove the battery pack and let it return to room temperature. Reinstall the battery pack. If the charge indicator or icon still does not turn on, replace the battery pack.

If the charge indicator still does not turn on, replace the system board. Then reinstall the battery pack. If it is still not charged, go to the next section.

Checking the battery pack

Battery charging does not start until the Power Meter shows that less than 95% of the total power remains; under this condition the battery pack can charge to 100% of its capacity. This protects the battery pack from being overcharged or from having a shortened life.

To check your battery, move your cursor to the Power Meter icon in the icon tray of the Windows taskbar and wait for a moment (but do not click), and the percentage of battery power remaining is displayed. To get detailed information about the battery, double-click the Power Meter icon.

Note: If the battery pack becomes hot, it may not be able to charge. Remove it from the computer and leave it at room temperature for a while. After it cools down, reinstall and recharge it.

To check the battery pack, do the following:

1. Power off the computer.
2. Remove the battery pack and measure the voltage between battery terminals 1 (+) and 5 (-). See the following figure:

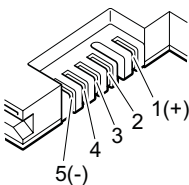

Terminal	Voltage (V dc)
1	+ 0 to + 12.6
5	Ground (-)

3. If the voltage is less than +11.0 V dc, the battery pack has been discharged.

Note: Recharging will take at least 3 hours, even if the indicator does not turn on.

If the voltage is still less than +11.0 V dc after recharging, replace the battery.

4. If the voltage is more than +11.0 V dc, measure the resistance between battery terminals 4 and 5. The resistance must be 4 to 30 K Ω .

If the resistance is not correct, replace the battery pack. If the resistance is correct, replace the system board.

Checking the backup battery

Do the following:

1. Power off the computer, and unplug the ac adapter from it.
2. Turn the computer upside down.
3. Remove the battery pack (see “1010 Battery pack (14.1-in. LCD models)” on page 72).
4. Remove the backup battery (see “Checking the battery pack” on page 43).
5. Measure the voltage of the backup battery. See the following figure.

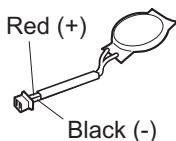

Wire	Voltage (V dc)
Red	+2.5 to +3.2
Black	Ground

- If the voltage is correct, replace the system board.
- If the voltage is not correct, replace the backup battery.
- If the backup battery discharges quickly after replacement, replace the system board.

ThinkPad T43 Series

Product overview	47
Specifications	47
Status indicators	50
FRU tests	53
Fn key combinations	55
Symptom-to-FRU index	58
Numeric error codes	58
Error messages	62
Beep symptoms	64
No-beep symptoms	64
LCD-related symptoms	65
Intermittent problems	66
Undetermined problems	66
FRU replacement notices	67
Screw notices	67
Retaining serial numbers.	68
Restoring the serial number of the system unit	68
Retaining the UUID	69
Reading or writing the ECA information	69
Removing and replacing a FRU.	71
1010 Battery pack (14.1-in. LCD models)	72
1020 Battery pack (15.0-in. LCD models)	74
1030 Ultrabay Slim device	75
1040 Hard disk drive	76
1050 DIMM (optional)	78
1060 Keyboard	80
1070 DIMM (standard)	84
1080 Modem daughter card (MDC-2)	85
1090 Bluetooth /Modem daughter card (BMDC-3)	87
1100 Palm rest or Palm rest with fingerprint reader (14.1-in. LCD models).	89
1110 Keyboard bezel or Keyboard bezel with fingerprint reader (15.0-in. LCD models)	92
1120 Mini PCI adapter	98
1130 Fan assembly	100
1140 Backup battery	104
1150 Speaker assembly	106
1160 Keyboard bezel (14.1-in. LCD models)	108
1170 PC Card/ExpressCard slots (14.1-in. LCD models)	110
1180 PC Card/ExpressCard slots (15.0-in. LCD models)	112
1190 LCD assembly (14.1-in. LCD models)	114
1200 LCD assembly (15.0-in. LCD models)	119
1210 CPU	124
1220 Ultrabay Slim guide rail assembly (14.1-in. LCD models)	125
1230 Ultrabay Slim guide rail assembly (15.0-in. LCD models)	127

1240 VGA and Ultrabay Slim device eject button cable	130
1250 System board and base cover (14.1-in. LCD models)	132
1260 System board, interposer card, and base cover (15.0-in. LCD models)	140
2010 LCD front bezel (14.1-in. LCD models)	148
2020 LCD front bezel (15.0-in. LCD models)	150
2030 Inverter card (14.1-in. LCD models)	152
2040 Inverter card (15.0-in. LCD models)	154
2050 Wireless antenna assemblies, LCD panel, LCD cable assembly, hinges, and LCD cover (14.1-in. LCD models)	155
2060 Wireless antenna assemblies, LCD panel, LCD cable assembly, hinges, and LCD cover (15.0-in. LCD models)	169
3010 ThinkPad Dock II PCI cover.	176
3020 ThinkPad Dock II top cover	177
Locations	180
Front view	180
Rear view.	182
Bottom view	183
Parts list	184
Overall	185
14.1-in. LCD FRUs	194
14.1-in. XGA TFT	195
15.0-in. LCD FRUs	196
15.0-in. XGA TFT	197
15.0-in. SXGA+ IPS TFT	198
Keyboard	199
Recovery CDs	203
Windows XP Professional	203
Windows XP Home Edition.	204
Miscellaneous parts	205
AC adapters	208
Optional FRUs	209
Common parts list	210
Tools	210
Power cords (system)	211
Power cords (ThinkPad Dock II)	212
Notices	213
Trademarks	215

Product overview

This section presents the following product-unique information:

- “Specifications”
- “Status indicators” on page 50
- “FRU tests” on page 53
- “Fn key combinations” on page 55

Specifications

The following table lists the specifications of the ThinkPad T43 series:

Feature	Description
Processor	<ul style="list-style-type: none"> • Intel® Pentium® M processor 730 (1.6 GHz), 2-MB L2 cache • Intel Pentium M processor 740 (1.73 GHz), 2-MB L2 cache • Intel Pentium M processor 750 (1.86 GHz), 2-MB L2 cache
Bus architecture	<ul style="list-style-type: none"> • 533-MHz PSB • 533-MHz DDR2 SDRAM (PC2-4200) • HUB link • PCI bus • LPC bus
Graphic memory chip	<ul style="list-style-type: none"> • Intel 915GM
Display	<ul style="list-style-type: none"> • 14.1-inch, 16M colors, XGA (1024 × 768 resolution) TFT color LCD • 15.0-inch, 16M colors, XGA (1024 × 768 resolution) TFT color LCD • 15.0-inch, 16M colors, SXGA+ (1400 × 1050 resolution) IPS (in-plane switching) TFT color LCD
Standard memory	<ul style="list-style-type: none"> • 256-MB DDR2-533 SDRAM SO-DIMM (PC2-4200) card × 1 • 512-MB DDR2-533 SDRAM SO-DIMM (PC2-4200) card × 1 • 1-GB DDR2-533 SDRAM SO-DIMM (PC2-4200) card × 1

(continued)

Feature	Description
Optional memory	<ul style="list-style-type: none"> • 256-MB DDR2-533 SDRAM SO-DIMM (PC2-4200) card × 1 • 512-MB DDR2-533 SDRAM SO-DIMM (PC2-4200) card × 1 • 1-GB DDR2-533 SDRAM SO-DIMM (PC2-4200) card × 1 (maximum of 2048 MB)
CMOS RAM	<ul style="list-style-type: none"> • 242 bytes
Hard disk drive	<ul style="list-style-type: none"> • 30.0 GB, 4200 rpm, 9.5 mm high, IDE interface • 40.0 GB, 4200 rpm, 9.5 mm high, IDE interface • 40.0 GB, 5400 rpm, 9.5 mm high, IDE interface • 60.0 GB, 5400 rpm, 9.5 mm high, IDE interface • 80.0 GB, 5400 rpm, 9.5 mm high, IDE interface • 60.0 GB, 7200 rpm, 9.5 mm high, IDE interface <p>Supported hard disk drives are depend on the model.</p>
Ultrabay Slim device (standard)	<ul style="list-style-type: none"> • DVD drive, 9.5 mm high • DVD/CD-RW combo drive, 9.5 mm high • DVD-RAM/RW drive, 9.5 mm high
Fingerprint reader	Some models
I/O port	<ul style="list-style-type: none"> • External monitor connector • Stereo headphone jack • Monaural microphone jack • Infrared port • Parallel connector • Docking connector • RJ11 connector • RJ45 connector • TV-out connector (S-Video) • Universal serial bus (USB) connector × 2 (compatible with USB 1.1 and 2.0)
Internal modem	<ul style="list-style-type: none"> • 56.6 Kbps
Audio	<ul style="list-style-type: none"> • Built-in stereo speakers • Software control volume
Infrared transfer	<ul style="list-style-type: none"> • IrDA 1.1
Ethernet (on the system board)	<ul style="list-style-type: none"> • Gigabit Ethernet



(continued)

Feature	Description
Mini PCI adapter	<ul style="list-style-type: none"> • Intel PRO Wireless 2200BG Mini-PCI Adapter • Intel PRO Wireless 2915ABG Mini-PCI Adapter
PC Card /ExpressCard slots	<ul style="list-style-type: none"> • ExpressCard (34 module, 54 module) for upper slot • PC Card (Type-II) for lower slot
Communication daughter card (CDC)	<ul style="list-style-type: none"> • ThinkPad Integrated 56K Modem (MDC-2) • ThinkPad Integrated <i>Bluetooth</i> IV with 56K Modem (BMDC-3)
Touch pad	<ul style="list-style-type: none"> • UltraNav
ThinkLight	Yes
Battery	<ul style="list-style-type: none"> • Li-ion battery (6 cells) 4.8 Ah • Li-ion battery (9 cells) 7.2 Ah • Ultrabay Slim Li Polymer battery (3 cells) (option)
AC adapter	<ul style="list-style-type: none"> • 72-watt type
Preinstalled operating system	<ul style="list-style-type: none"> • Windows XP Professional • Windows XP Home Edition



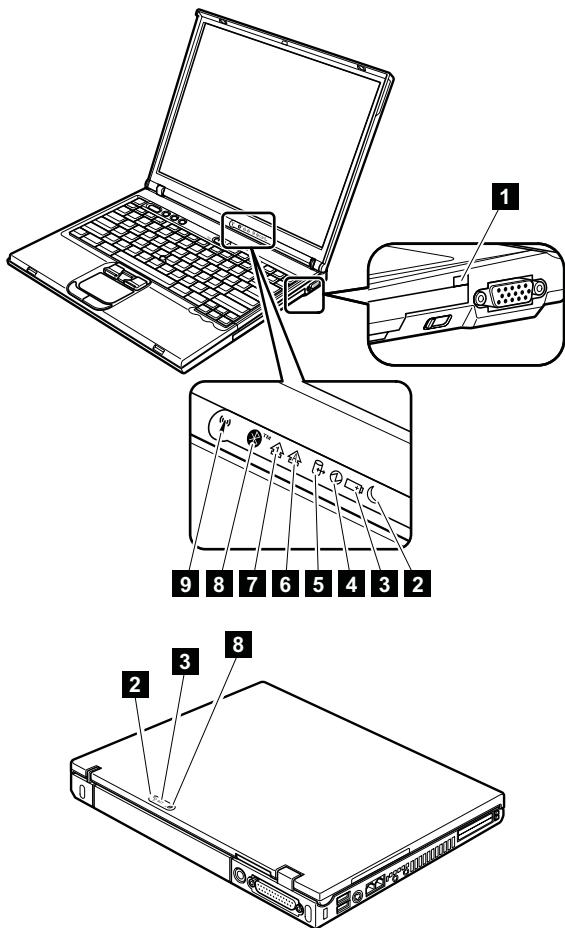

Status indicators

The system status indicators show the status of the computer, as follows:



Indicator	Meaning
<p>1 Ultrabay Slim status</p>	<p>Green: An Ultrabay Slim device is installed and in use.</p> <p>Blinking green: An Ultrabay Slim device is in the process of being detached.</p> <p>Turn off: An Ultrabay Slim device is ready to be attached or detached.</p> <p>Note: If you are using Windows 2000, the Ultrabay Slim status indicator does not blink while an Ultrabay Slim device is being detached. Instead, a message box pops up when the process is completed; then the indicator turns off.</p>
<p>2 Standby status</p> 	<p>Green: The computer is in standby mode.</p> <p>Blinking green: The computer is entering standby mode or hibernation mode, or is resuming normal operation.</p>
<p>3 Battery status</p> 	<p>Green: The battery is in use and has enough power. The ac adapter has charged the battery completely.</p> <p>Blinking green: The battery is being charged, but still has enough power to operate. (At regular intervals, the indicator light turns off briefly.)</p> <p>Orange: The battery is being charged, but the battery power is still low.</p> <p>Blinking orange: The battery needs to be charged. When the indicator starts blinking orange, the computer beeps three times.</p>
<p>4 Power on</p> 	<p>Green: The computer is on and ready to use. This indicator stays lit whenever the computer is on and is not in standby mode.</p>

(continued)

Indicator	Meaning
<p>5 Drive in use</p> 	<p>Green:</p> <p>Data is being read from or written to the hard disk drive, the diskette drive, or the drive in the Ultrabay Slim device. When this indicator is on, do not put the computer into standby mode or turn off the computer.</p> <p>Note: Do not move the system while the green drive-in-use light is on. Sudden physical shock could cause drive errors.</p>
<p>6 Caps lock</p> 	<p>Green:</p> <p>Caps Lock mode is enabled. To enable or disable Caps Lock mode, press the Caps Lock key.</p>
<p>7 Num lock</p> 	<p>Green:</p> <p>The numeric keypad on the keyboard is enabled. To enable or disable the keypad, press and hold the Shift key, and press the NumLk (ScrLk) key.</p>
<p>8 Bluetooth status</p> 	<p>Green:</p> <p>Bluetooth wireless is operational. This indicator is on when Bluetooth wireless is on and not in suspend mode.</p>
<p>9 Wireless status</p> 	<p>Green:</p> <p>The wireless feature (the IEEE 802.11 standard) is on, and the radio link is ready for use.</p> <p>Blinking green:</p> <p>Data is being transmitted.</p>

FRU tests

The following table shows the test for each FRU.

FRU	Applicable test
System board	<ol style="list-style-type: none"> 1. Diagnostics --> CPU/Coprocessor 2. Diagnostics --> Systemboard 3. If the docking station or the port replicator is attached to the ThinkPad computer, undock it. Place the computer on a horizontal surface, and run Diagnostics --> ThinkPad Devices --> HDD Active Protection Test. Note: Do not apply any physical shock to the computer while the test is running.
Power	Diagnostics --> ThinkPad Devices --> AC Adapter, Battery 1 (Battery 2)
LCD unit	<ol style="list-style-type: none"> 1. Diagnostics --> Video Adapter 2. Interactive Tests --> Video
Modem daughter card (MDC-2) or Bluetooth /Modem daughter card (BMDC-3)	<ol style="list-style-type: none"> 1. Make sure the modem is set up correctly. 2. Replace the modem jack and the modem card in turn, and run the following tests in Diagnostics --> Communication: <ol style="list-style-type: none"> a. Conexant Smart Modem Interrupt b. Conexant Smart Modem Dialtone
Audio	<ol style="list-style-type: none"> 1. Interactive Tests --> Internal Speaker 2. Diagnostics --> Other Devices --> Analog Devices AC97 CODEC Test
Speaker	Interactive Tests --> Internal Speaker
PC Card slot	<ol style="list-style-type: none"> 1. Diagnostics --> Systemboard --> PCMCIA 2. Insert a PC Card Wrap Plug into every PC Card slot, and run Diagnostics --> Systemboard --> PCMCIA External Loop
ExpressCard slot	<ol style="list-style-type: none"> 1. Insert a PCI-Express/USB Wrap card into the ExpressCard slot. 2. Turn on the computer. 3. Run Diagnostics --> ThinkPad Devices --> ExpressCard slot.
Keyboard	<ol style="list-style-type: none"> 1. Diagnostics --> Systemboard --> Keyboard 2. Interactive Tests --> Keyboard
Hard disk drive	Diagnostics --> Fixed Disks
Diskette drive	<ol style="list-style-type: none"> 1. Diagnostics --> Diskette Drives 2. Interactive Tests --> Diskette
DVD drive or DVD/CD-RW combo drive	<ol style="list-style-type: none"> 1. Diagnostics --> Other Devices --> CD-ROM/DVD 2. Interactive Tests --> CD-ROM/DVD Test

(continued)

FRU	Applicable test
Memory	<ol style="list-style-type: none"> 1. If two DIMMs are installed, remove one of them and run Diagnostics --> Memory Test—Quick. 2. If the problem does not recur, return the DIMM to its place, remove the other one, and run the test again. 3. If the test does not detect the error, run Diagnostics --> Memory Test—Full.
Fan	<ol style="list-style-type: none"> 1. Turn on the computer and check the air turbulence at the louver near the PC Card slot. 2. Run Diagnostics --> ThinkPad Devices --> Fan.
TrackPoint or pointing device	<p>If the TrackPoint does not work, check the configuration as specified in the ThinkPad Configuration program. If the TrackPoint is disabled, select Automatic to enable it.</p> <p>After you use the TrackPoint, the pointer may drift on the screen for a short time. This drift can occur when a slight, steady pressure is applied to the TrackPoint pointer. This symptom is not a hardware problem. If the pointer stops after a short time, no service action is necessary.</p> <p>If enabling the TrackPoint does not correct the problem, continue with the following:</p> <ul style="list-style-type: none"> • Interactive Tests --> Mouse
Touch Pad	<p>If the Touch Pad does not work, check the configuration as specified in the ThinkPad Configuration program. If the Touch Pad is disabled, select Automatic to enable it. If enabling the Touch Pad does not correct the problem, continue with the following:</p> <ul style="list-style-type: none"> • Interactive Tests --> Mouse

Fn key combinations

The following table shows the function of each combination of Fn with a function key.

Key combination	Description
Fn+F1	Reserved.
Fn+F2	Reserved.
Fn+F3	Turn off the computer display, leaving the screen blank. To turn the computer display on again, press any key or press the TrackPoint pointing stick.
Fn+F4	Put the computer in standby mode. To return to normal operation, press the Fn key only, without pressing a function key. Notes: <ol style="list-style-type: none"> 1. This mode is called suspend mode in Windows NT. 2. In Windows 2000 and Windows XP, this combination of keys functions as a sleep button. The setting can be changed so that pressing it puts the computer into hibernation mode or even shuts the computer down.
Fn+F5	Control the power source of the built-in <i>Bluetooth</i> wireless device. This combination of the keys functions as a toggle switch of the power state. Note: In Windows 2000 or Windows XP, this combination of keys enables or disables the built-in wireless networking features (the IEEE 802.11 standard) and the <i>Bluetooth wireless</i> features. To use this function, the following drivers must be installed. <ul style="list-style-type: none"> • ThinkPad Power Management driver • OnScreen Display utility • Wireless device drivers
Fn+F6	Reserved.

(continued)

Key combination	Description
Fn+F7	<p>Switch a display output location</p> <ul style="list-style-type: none"> • External monitor (CRT display) • Computer display and external monitor (LCD + CRT display) • Computer display (LCD) <p>Note: For any operating system other than Windows 2000 or Windows XP, no additional procedure is needed; just press Fn+F7.</p> <p>Notes:</p> <ol style="list-style-type: none"> 1. This function does not work when different desktop images are displayed on the computer display and the external monitor (the Extend desktop function). 2. This function does not work while a DVD movie or a video clip is playing. 3. For Windows 2000 or Windows XP, a hotkey application might take over the switching function.
Fn+F8	<p>Note: This function is not supported in Windows 2000 and Windows XP.</p> <p>If the image displayed on the computer is smaller than the physical display, switch the computer screen size between expanded mode and normal mode.</p>

(continued)

Key combination	Description
Fn+F9	<p>Open the ThinkPad EasyEject Utility screen. Buttons for the following choices are displayed:</p> <ul style="list-style-type: none"> • Eject ThinkPad PC from Dock: This button is displayed only if the ThinkPad computer has been attached to a ThinkPad Dock II. The computer can be detached from the ThinkPad Dock II. • Eject ThinkPad PC from Mini Dock: This button is displayed only if the ThinkPad computer has been docked in a ThinkPad Mini Dock and one or more USB devices have been connected to the ThinkPad Mini Dock. You can stop and remove all the USB devices safely by clicking the button. Note: If a diskette drive is connected to the external-diskette-drive connector of the ThinkPad Mini Dock, you cannot connect a USB diskette drive. • Run EasyEject Actions: This button is used to select, stop, or remove external devices connected to the ThinkPad computer. • Configure EasyEject Actions: Opens the ThinkPad EasyEject Utility main window. • Fn+F9 Settings: Configures the settings for the Fn+F9 function. <p>You can use this utility to stop and remove all ejectable devices connected to the ThinkPad computer, the ThinkPad Mini Dock, or the ThinkPad Port Replicator II. You cannot use it to detach the computer from the ThinkPad Mini Dock or the ThinkPad Port Replicator II. Note: This function is supported only in Windows 2000 and Windows XP.</p>
Fn+F10	Reserved.
Fn+F11	Reserved.
Fn+F12	<p>Put the computer into hibernation mode. To return to normal operation, press the power button for less than four seconds.</p> <p>Note: To use Fn+F12 for hibernation in Windows 2000 or Windows XP, you must have the PM device driver installed on the computer.</p>
Fn+PgUp	<p>Turn the ThinkLight on or off.</p> <p>Note: This function is supported only on the ThinkPad computers that have the ThinkLight. The on or off status of the ThinkLight is shown on the screen for a few seconds when you press Fn+PgUp.</p>
Fn+Home	The computer display becomes brighter.
Fn+End	The computer display becomes dimmer.
Fn+Spacebar	Enable the FullScreen Magnifier function.

Symptom-to-FRU index

The symptom-to-FRU index in this section lists symptoms and errors and their possible causes. The most likely cause is listed first, in boldface type.

Note: Do the FRU replacement or other actions in the sequence shown in the column headed “FRU or action, in sequence.” If replacing a FRU does not solve the problem, put the original part back in the computer. Do not replace a nondefective FRU.

This index can also help you determine, during regular servicing, what FRUs are likely to need to be replaced next.

A numeric error is displayed for each error detected in POST or system operation. In the displays, **n** can be any number.

If no numeric code is displayed, check the narrative descriptions of symptoms. If the symptom is not described there, go to “Intermittent problems” on page 66.

Note

For a device not supported by diagnostic codes in the ThinkPad notebook computers, see the manual for that device.

Numeric error codes

Symptom or error	FRU or action, in sequence
0175 Bad CRC1, stop POST task—The EEPROM checksum is not correct.	System board.
0176 System Security—The system has been tampered with.	<ol style="list-style-type: none"> Run BIOS Setup Utility, and save the current setting by pressing F10. System board.
0177 Bad SVP data, stop POST task—The checksum of the supervisor password in the EEPROM is not correct.	System board.
0182 Bad CRC2. Enter BIOS Setup and load Setup defaults.—The checksum of the CRS2 setting in the EEPROM is not correct.	<ol style="list-style-type: none"> Run BIOS Setup Utility. Press F9, and Enter to load the default setting. Then save the current setting by pressing F10. System board.

Symptom or error	FRU or action, in sequence
0185 Bad startup sequence settings. Enter BIOS Setup and load Setup defaults.	1. Run BIOS Setup Utility. Press F9, and Enter to load the default setting. Then save the current setting by pressing F10.
0187 EAIA data access error—The access to EEPROM is failed.	System board.
0188 Invalid RFID Serialization Information Area.	System board.
0189 Invalid RFID configuration information area—The EEPROM checksum is not correct.	System board.
0190 Critical low-battery error	1. Charge the battery pack. 2. Battery pack.
0191 System Security—Invalid Remote Change requested.	1. Run BIOS Setup Utility, and then save current setting by pressing F10. 2. System board.
0192 System Security— IBM Embedded Security hardware tamper detected.	System board.
0199 System Security—IBM Security password retry count exceeded.	1. Run BIOS Setup Utility, and then save the current setting by pressing F10. 2. System board.
01C8 Two or more modem devices are found. Remove all but one of them. Press <Esc> to continue.	1. Remove either a Mini-PCI Card or a modem daughter card. Otherwise, press Esc to ignore the warning message. 2. System board.
01C9 More than one Ethernet devices are found. Remove one of them. Press <Esc> to continue.	1. Remove the Ethernet device that you installed; or press Esc to ignore the warning message. 2. System board.
0200 Hard disk error—The hard disk is not working.	1. Reseat the hard disk drive. 2. Load Setup Defaults in BIOS Setup Utility. 3. Hard disk drive. 4. System board.
021x Keyboard error.	Run interactive tests of the keyboard and the auxiliary input device.

Symptom or error	FRU or action, in sequence
0220 Monitor type error—Monitor type does not match the one specified in CMOS.	Load Setup Defaults in BIOS Setup Utility.
0230 Shadow RAM error—Shadow RAM fails at offset nnnn.	System board.
0231 System RAM error—System RAM fails at offset nnnn.	1. DIMM. 2. System board.
0232 Extended RAM error—Extended RAM fails at offset nnnn.	1. DIMM. 2. System board.
0250 System battery error—System battery is dead.	Replace the backup battery and run BIOS Setup Utility to reset the time and date.
0251 System CMOS checksum bad— Default configuration used.	Replace the backup battery and run BIOS Setup Utility to reset the time and date.
0252 Password checksum bad—The password is cleared.	Reset the password by running BIOS Setup Utility.
0260 System timer error.	1. Replace the backup battery and run BIOS Setup Utility to reset the time and date. 2. System board.
0270 Real-time clock error.	1. Replace the backup battery and run BIOS Setup Utility to reset the time and date. 2. System board.
0271 Date and time error—Neither the date nor the time is set in the computer.	Run BIOS Setup Utility to reset the time and date.
0280 Previous boot incomplete—Default configuration used.	1. Load “Setup Default” in BIOS Setup Utility. 2. DIMM. 3. System board.
02F5 DMA test failed.	1. DIMM. 2. System board.
02F6 Software NMI failed	1. DIMM. 2. System board.
02F7 Fail-safe timer NMI failed	1. DIMM. 2. System board.
1802 Unauthorized network card is plugged in—Turn off and remove the miniPCI network card.	1. Remove Mini PCI network card. 2. System board.

Symptom or error	FRU or action, in sequence
<p>1803 Unauthorized daughter card is plugged in—Turn off and remove the daughter card.</p>	<ol style="list-style-type: none"> 1. Remove the daughter card that you installed. 2. System board.
<p>1810 Hard disk partition layout error.</p>	<ol style="list-style-type: none"> 1. If the Access IBM Predesktop Area has been previously disabled, then go to the BIOS Setup Utility by pressing F1 to open the BIOS Setup Utility. Select Security --> Predesktop Area --> Access IBM Predesktop Area. Set this item to Disabled. Save and exit. 2. If the Access IBM Predesktop Area has not been previously disabled, press Enter to load Access IBM Predesktop Area. Then run RECOVER TO FACTORY CONTENTS in Access IBM Predesktop Area. 3. If item 2 failed, press F3 in the Welcome screen in RECOVER TO FACTORY CONTENTS. Run FDISK, and then delete all partitions. Run RECOVER TO FACTORY CONTENTS in Access IBM Predesktop Area again. 4. If item 3 failed, select CD-ROM boot in Startup in Access IBM Predesktop Area. Boot from the Recovery CD and perform full recovery from it. 5. If item 4 failed, replace the hard disk drive.
<p>2000 IBM Hard Drive Active Protection sensor diagnostics failed. Press <Esc> to continue. Press <F1> to enter SETUP</p>	<ol style="list-style-type: none"> 1. Undock docking station or port replicator if it is attached to the ThinkPad computer, and place the computer on a horizontal surface. Do not apply any physical shock to the computer. 2. Run Diagnostics --> ThinkPad Devices --> HDD Active Protection Test.

Error messages

Symptom or error	FRU or action, in sequence
Device address conflict.	<ol style="list-style-type: none"> 1. Load “Setup Defaults” in the BIOS Setup Utility. 2. Backup battery. 3. System board.
Allocation error for device.	<ol style="list-style-type: none"> 1. Load “Setup Defaults” in the BIOS Setup Utility. 2. Backup battery. 3. System board.
Failing bits: nnnn.	<ol style="list-style-type: none"> 1. DIMM. 2. System board.
Invalid system configuration data.	<ol style="list-style-type: none"> 1. DIMM. 2. System board.
I/O device IRQ conflict.	<ol style="list-style-type: none"> 1. Load “Setup Defaults” in the BIOS Setup Utility. 2. Backup battery. 3. System board.
Operating system not found.	<ol style="list-style-type: none"> 1. Check that the operating system has no failure and is installed correctly. 2. Enter the BIOS Setup Utility and see whether the hard disk drive and the diskette drive are properly identified. 3. Reseat the hard disk drive. 4. Reinstall the operating system. 5. Diskette drive. 6. Hard disk drive. 7. System board.
Hibernation error.	<ol style="list-style-type: none"> 1. Restore the system configuration to what it was before the computer entered hibernation mode. 2. If memory size has been changed, re-create the hibernation file.
Fan error.	Fan.
Thermal sensing error.	System board.
Authentication of system services failed. Press <Esc> to resume.	The Predesktop Area in the HDD is corrupted. Restore it from a recovery CD.

Symptom or error	FRU or action, in sequence
Cannot boot from any device.	<p>Check the status of device which you want to boot from.</p> <p>Device not found.</p> <ol style="list-style-type: none"> 1. The device you want to boot from. 2. System board. <p>Device Error.</p> <ol style="list-style-type: none"> 1. The device you want to boot from. 2. System board. <p>No valid operating system.</p> <ol style="list-style-type: none"> 1. Check that the operating system has no failure and is installed correctly. 2. Reinstall the operation system. <p>Excluded from boot order.</p> <ul style="list-style-type: none"> • Enter the BIOS Setup Utility and add the device in boot order.

Beep symptoms

Symptom or error	FRU or action, in sequence
One beep and a blank, unreadable, or flashing LCD.	<ol style="list-style-type: none"> 1. Reseat the LCD connector. 2. LCD assembly. 3. External CRT. 4. System board.
One long and two short beeps, and a blank or unreadable LCD.	<ol style="list-style-type: none"> 1. System board. 2. LCD assembly. 3. DIMM.
Two short beeps with error codes.	POST error. See “Numeric error codes” on page 58.
Two short beeps and a blank screen.	<ol style="list-style-type: none"> 1. System board. 2. DIMM.
Three short beeps, pause, three more short beeps, and one short beep.	<ol style="list-style-type: none"> 1. DIMM. 2. System board
One short beep, pause, three short beeps, pause, three more short beeps, and one short beep.	
Only the cursor appears.	Reinstall the operating system.
Four cycles of four short beeps and a blank screen.	System board (security chip)
Five short beeps and a blank screen.	System board

No-beep symptoms

Symptom or error	FRU or action, in sequence
No beep, power-on indicator on, LCD blank, and no POST.	<ol style="list-style-type: none"> 1. Make sure that every connector is connected tightly and correctly. 2. DIMM. 3. System board.
No beep, power-on indicator on, and LCD blank during POST.	<ol style="list-style-type: none"> 1. Reseat DIMM. 2. System board.
The power-on password prompt appears.	A power-on password or a supervisor password is set. Type the password and press Enter .
The hard-disk password prompt appears.	A hard-disk password is set. Type the password and press Enter .
The DOS full screen looks smaller than it should.	Start the ThinkPad Configuration program and set the Screen expansion function.

LCD-related symptoms

Important

The TFT LCD for the notebook computer contains many thin-film transistors (TFTs). The presence of a small number of dots that are missing, discolored, or always lighted is characteristic of TFT LCD technology, but excessive pixel problems can cause viewing concerns. The LCD should be replaced if the number of missing, discolored, or lighted dots in any background is:

- **XGA:** 8 or more bright dots, 8 or more dark dots, or a total of 9 or more bright and dark dots.
- **SXGA+:** 11 or more bright dots, 13 or more dark dots, or a total of 16 or more bright and dark dots.

Note: A bright dot means a pixel is always on (white or color.) A dark dot means a pixel is always off (black color.)

Symptom or error	FRU or action, in sequence
No beep, power-on indicator on, and a blank LCD during POST.	System board.
<ul style="list-style-type: none"> • LCD backlight not working. • LCD too dark. • LCD brightness cannot be adjusted. • LCD contrast cannot be adjusted. 	<ol style="list-style-type: none"> 1. Reseat the LCD connectors. 2. LCD assembly. 3. System board.
<ul style="list-style-type: none"> • LCD screen unreadable. • Characters missing pixels. • Screen abnormal. • Wrong color displayed. 	<ol style="list-style-type: none"> 1. See important note for “LCD-related symptoms.” 2. Reseat all LCD connectors. 3. LCD assembly. 4. System board.
Horizontal or vertical lines displayed on LCD.	LCD assembly.

Intermittent problems

Intermittent system hang problems can be due to a variety of causes that have nothing to do with a hardware defect, such as cosmic radiation, electrostatic discharge, or software errors. FRU replacement should be considered only when a problem recurs.

When analyzing an intermittent problem, do the following:

1. Run the diagnostic test for the system board in loop mode **at least 10 times**.
2. If no error is detected, do **not** replace any FRUs.
3. If any error is detected, replace the FRU shown by the FRU code. Rerun the test to verify that no more errors exist.

Undetermined problems

If the diagnostic tests did not identify the adapter or device that has failed, if wrong devices are installed, or if the system simply is not operating, follow these procedures to isolate the failing FRU (do not isolate FRUs that have no defects).

Verify that all attached devices are supported by the computer.

Verify that the power supply being used at the time of the failure is operating correctly. (See “Power system checkout” on page 42.)

1. Turn off the computer.
2. Visually check each FRU for damage. Replace any damaged FRU.
3. Remove or disconnect all of the following devices:
 - a. Non-ThinkPad devices
 - b. Devices attached to the port replicator
 - c. Printer, mouse, and other external devices
 - d. Battery pack
 - e. Hard disk drive
 - f. External diskette drive
 - g. DIMM
 - h. CD-ROM and diskette drive in the Ultrabay
 - i. PC Cards
4. Turn on the computer.
5. Determine whether the problem has been solved.
6. If the problem does not recur, reconnect the removed devices one at a time until you find the failing FRU.
7. If the problem remains, replace the following FRUs one at a time (do not replace a nondefective FRU):
 - a. System board
 - b. LCD assembly

FRU replacement notices

This section contains notices related to removing and replacing parts. Read this section carefully before replacing any FRU.

Screw notices

Loose screws can cause a reliability problem. In the ThinkPad computer, this problem is addressed with special nylon-coated screws that have the following characteristics:

- They maintain tight connections.
- They do not easily come loose, even with shock or vibration.
- They are harder to tighten.
- Each one should be used only once.

Do the following when you service this machine:

- Keep the screw kit (for the P/N, see “Miscellaneous parts” on page 205) in your tool bag.
- Always use new screws.
- Use a torque screwdriver if you have one.

Tighten screws as follows:

- **Plastic to plastic**

Turn an additional **90 degrees** after the screw head touches the surface of the plastic part:

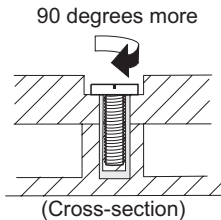

- **Logic card to plastic**

Turn an additional **180 degrees** after the screw head touches the surface of the logic card:

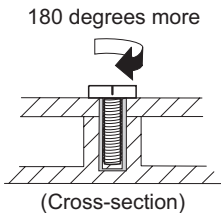

- **Torque driver**

If you have a torque driver, refer to the “Torque” column for each step.

- Make sure that you use the correct screw. If you have a torque screwdriver, tighten all screws firmly to the torque shown in the table. **Never use a screw that you removed. Use a new one. Make sure that all of the screws are tightened firmly.**

Retaining serial numbers

This section includes the following descriptions:

- “Restoring the serial number of the system unit”
- “Retaining the UUID” on page 69
- “Reading or writing the ECA information” on page 69

Restoring the serial number of the system unit

When the computer was manufactured, the EEPROM on the system board was loaded with the serial numbers of the system and all major components. These numbers need to remain the same throughout the life of the computer.

If you replace the system board, you must restore the serial number of the system unit to its original value.

Before replacing the system board, save the original serial number by doing the following:

1. Install the ThinkPad Hardware Maintenance Diskette Version 1.73 or later, and restart the computer.
2. From the main menu, select **1. Set System Identification**.
3. Select **2. Read S/N data from EEPROM**.

The serial number of each device in your computer is displayed; the serial number of the system unit is listed as follows:

- 20: Serial number

Write down that number.

Note: The serial number of the system unit is also written on the label attached to the bottom of the computer.

After you have replaced the system board, restore the serial number by doing the following:

1. Install the ThinkPad Hardware Maintenance Diskette Version 1.73 or later and restart the computer.
2. From the main menu, select **1. Set System Identification**.
3. Select **1. Add S/N data from EEPROM**.
Follow the instructions on the screen.

Retaining the UUID

The Universally Unique Identifier (UUID) is a 128-bit number uniquely assigned to your computer at production and stored in the EEPROM of your system board. The algorithm that generates the number is designed to provide unique IDs until the year A.D. 3400. No two computers in the world have the same number.

When you replace the system board, you must set the UUID on the new system board as follows:

1. Install the ThinkPad Hardware Maintenance Diskette Version 1.73 or later, and restart the computer.
2. From the main menu, select **4. Assign UUID.**

A new UUID is created and written. If a valid UUID already exists, it is not overwritten.

Reading or writing the ECA information

Information on Engineering Change Announcements (ECA) are stored in the EEPROM of the system board. The electronic storage of this information simplifies the procedure to check if the ECA has been previously applied to a machine. The machine does not need to be disassembled to check for the ECA application.

To check what ECAs have been previously applied to the machine, use the ECA Information Read/Write function on the ThinkPad Hardware Maintenance Diskette Version 1.73 or later.

1. Insert the ThinkPad Hardware Maintenance Diskette Version 1.73 or later, and restart the computer.
2. From the main menu, select **6. Set ECA Information.**
3. To read ECA information, select **2. Read ECA/rework number from EEPROM** and follow the instruction.
4. To read box build date, select **5. Read box build date from EEPROM**, and follow the instruction on the screen.

After an ECA has been applied to the machine, the EEPROM must be updated to reflect the ECA's application. Use the ThinkPad Hardware Maintenance Diskette Version 1.73 or later to update the EEPROM.

Note: Only the ECA number is stored in the EEPROM. The machine type of the ECA is assumed be the same as the machine type of the machine that had the ECA applied to it.

1. Insert the ThinkPad Hardware Maintenance Diskette Version 1.73 or later, and restart the computer.
2. From the main menu, select **6. Set ECA Information.**

3. To write ECA information, select **1. Write ECA/rework number from EEPROM**, and follow the instruction.
4. To write box build date, select **4. Write box build date from EEPROM**, and follow the instruction on the screen.

If the system board is being replaced, try to read the ECA information from the old system board and transfer the information to the new system. If the system board is inoperable, this will not be possible.

Removing and replacing a FRU

This section presents directions and drawings for use in removing and replacing a FRU. Be sure to observe the following general rules:

1. Do not try to service any computer unless you have been trained and certified. An untrained person runs the risk of damaging parts.
2. Before replacing any FRU, review “FRU replacement notices” on page 67.
3. Begin by removing any FRUs that have to be removed before the failing FRU. Any such FRUs are listed at the top of the page. Remove them in the order in which they are listed.
4. Follow the correct sequence in the steps for removing the FRU, as given in the drawings by the numbers in square callouts.
5. When turning a screw to replace a FRU, turn it in the direction as given by the arrow in the drawing.
6. When removing the FRU, move it in the direction as given by the arrow in the drawing.
7. To put the new FRU in place, reverse the removal procedure and follow any notes that pertain to replacement. For information about connecting and arranging internal cables, see “Locations” on page 180.
8. When replacing a FRU, use the correct screw as shown in the procedures.

DANGER

Before removing any FRU, turn off the computer, unplug all power cords from electrical outlets, remove the battery pack, and then disconnect any interconnecting cables.

Attention: After replacing a FRU, do not turn on the computer until you have made sure that all screws, springs, and other small parts are in place and none are loose inside the computer. Verify this by shaking the computer gently and listening for rattling sounds. Metallic parts or metal flakes can cause electrical short circuits.

Attention: The system board is sensitive to, and can be damaged by, electrostatic discharge. Before touching it, establish personal grounding by touching a ground point with one hand or by using an electrostatic discharge (ESD) strap (P/N 6405959).

1010 Battery pack (14.1-in. LCD models)

 **DANGER**

Use only the battery specified in the parts list for your computer. Any other battery could ignite or explode.

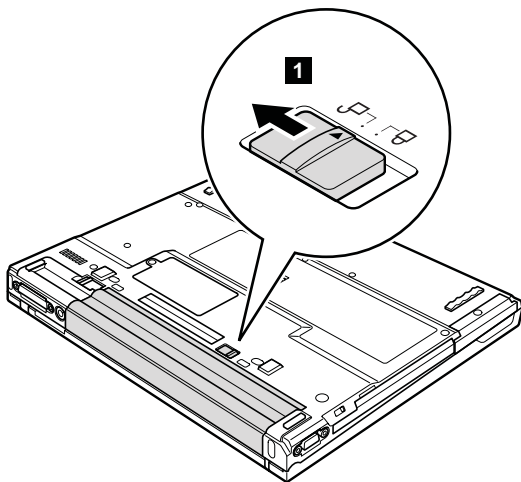

(continued)

Holding the battery release lever in the unlocked position **2**, remove the battery pack **3**.

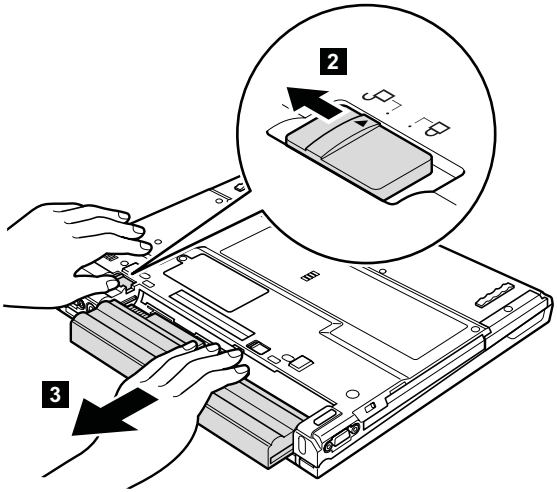

When installing: Install the battery pack along the slide rails on the left and right sides of the battery-pack slot. Then make sure that both battery latches, **a** and **b**, are locked, as in the following figure.

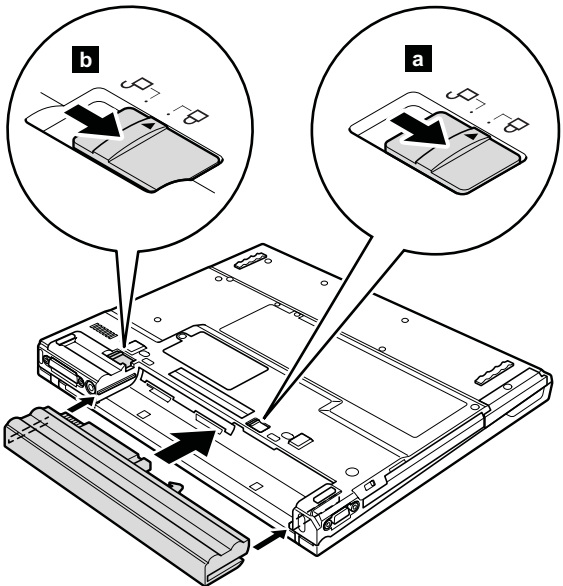

1020 Battery pack (15.0-in. LCD models)

⚠ DANGER

Use only the battery specified in the parts list for your computer. Any other battery could ignite or explode.

Holding the battery release lever in the unlocked position **1**, remove the battery pack **2**.

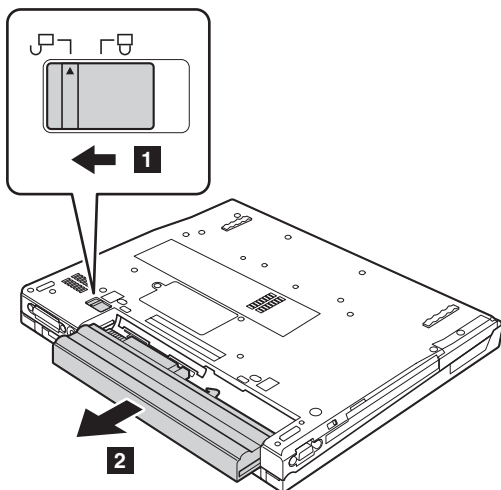

1030 Ultrabay Slim device

Note

Ultrabay Slim does not accept any of the following devices:

- Ultrabay Plus devices
- Ultrabay 2000 devices

For devices compatible with the Ultrabay Slim bay, see “Optional FRUs” on page 209.

Note: When you release the switch in step **1**, the lever pops out. In step **2**, pull the lever a little to release the device from the bay.

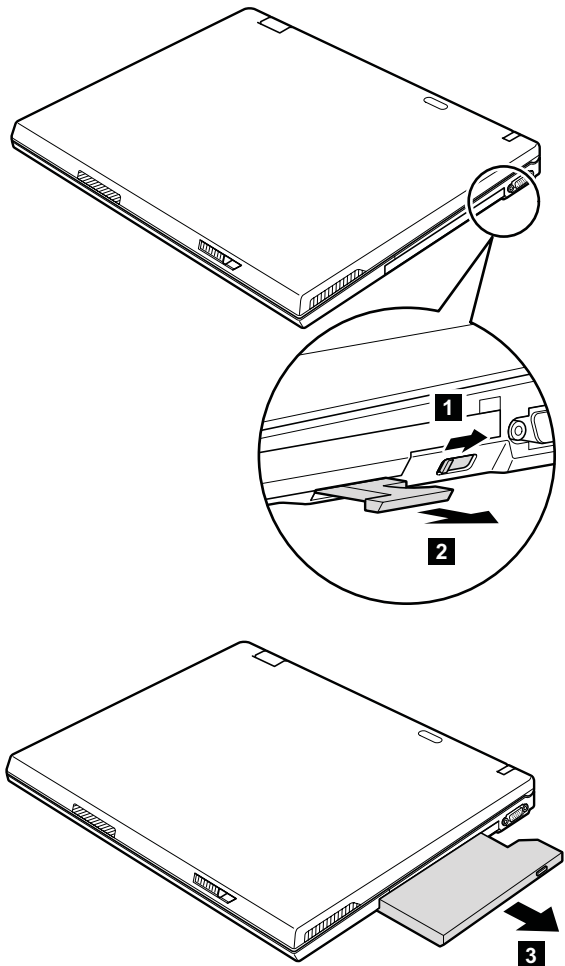

1040 Hard disk drive

Attention

- **Do not drop the hard disk drive or apply any physical shock to it.** The hard disk drive is sensitive to physical shock. Improper handling can cause damage and permanent loss of data.
- Before removing the drive, have the user make a backup copy of all the information on it if possible.
- Never remove the drive while the system is operating or is in suspend mode.

For access, remove this FRU:

- “1010 Battery pack (14.1-in. LCD models)” on page 72
- “1020 Battery pack (15.0-in. LCD models)” on page 74

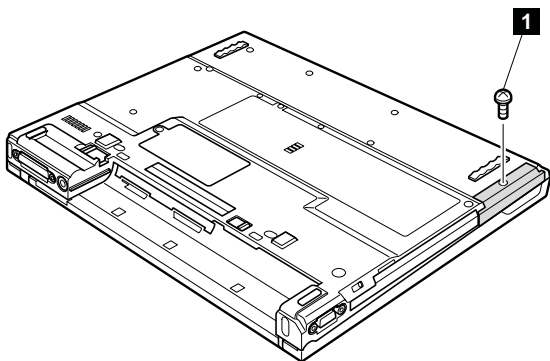

Note: The hard disk is attached to the cover.

Step	Screw (quantity)
1	HDD screw (1) or security screw (1)
Note: Use a 2.5-mm Allen wrench to remove the security screw.	

(continued)

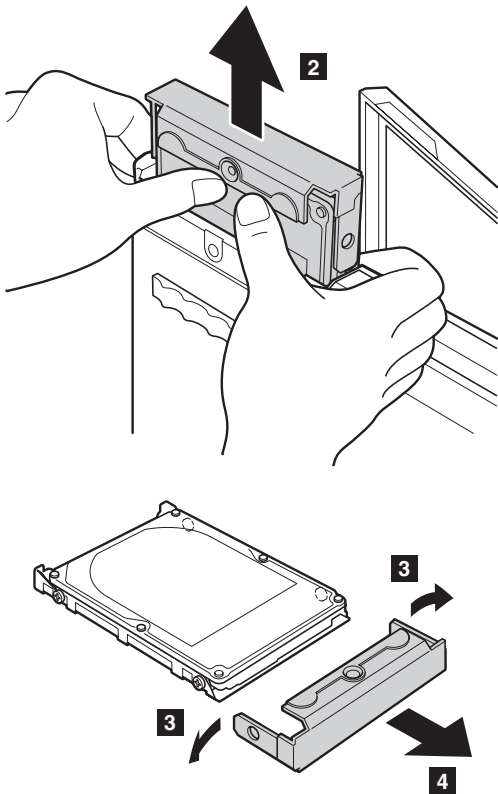

When installing: Make sure that the hard-disk connector is attached firmly.

1050 DIMM (optional)

For access, remove this FRU:

- “1010 Battery pack (14.1-in. LCD models)” on page 72
- “1020 Battery pack (15.0-in. LCD models)” on page 74

Note: Loosen the screw **1**, but do not remove it.

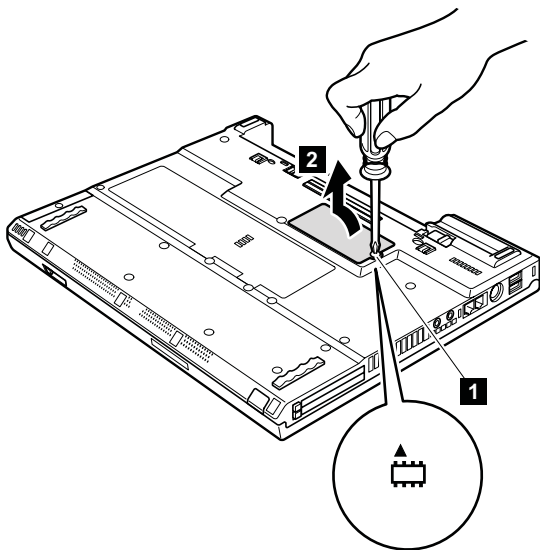

(continued)

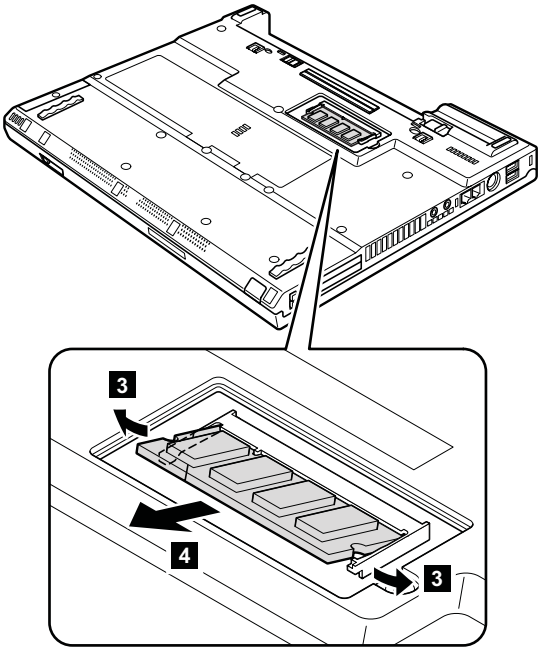

When installing: Insert the notched end of the DIMM into the socket. Press the DIMM firmly, and pivot it until it snaps into the place. Make sure that it is firmly fixed in the slot and does not move easily.

1060 Keyboard

For access, remove this FRU:

- “1010 Battery pack (14.1-in. LCD models)” on page 72
- “1020 Battery pack (15.0-in. LCD models)” on page 74

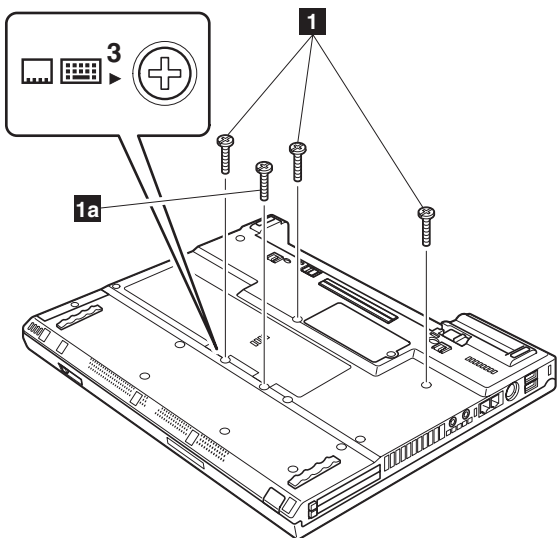

Note: Screw **1a** is only for the models with 14.1-in. LCD. Other models do not have this screw.

Step	Icon	Screw (quantity)	Color	Torque
1		M2 × 10 mm, flat-head, nylon-coated (3)	Black	0.245 Nm (2.5 kgfcm)
1a		M2 × 10 mm, flat-head, nylon-coated (1)	Black	0.245 Nm (2.5 kgfcm)

(continued)

Press the part indicated by the arrow **2** in the direction of the arrow. This releases the latches of the keyboard from the frame, so that the front side of the keyboard pops out.

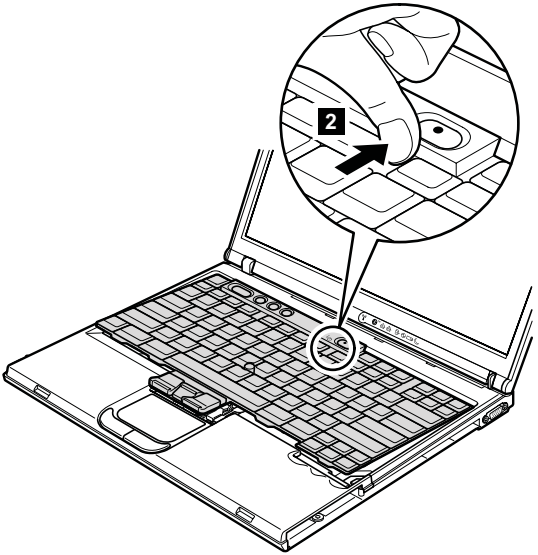

Pull the keyboard a little in the direction of the arrow **3**, and then detach the connector **4**.

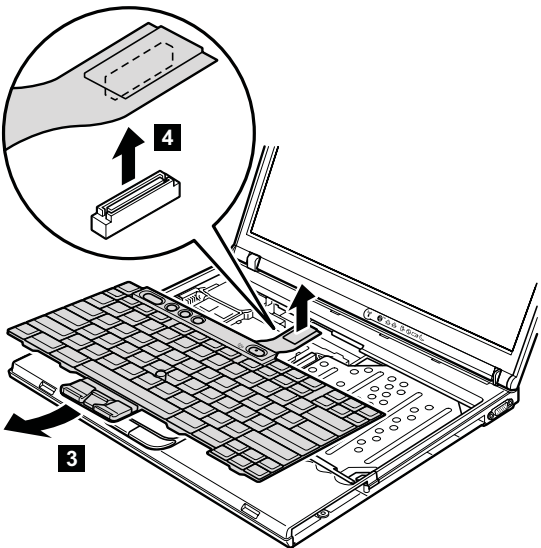

When installing:

1. Attach the connector **1**.

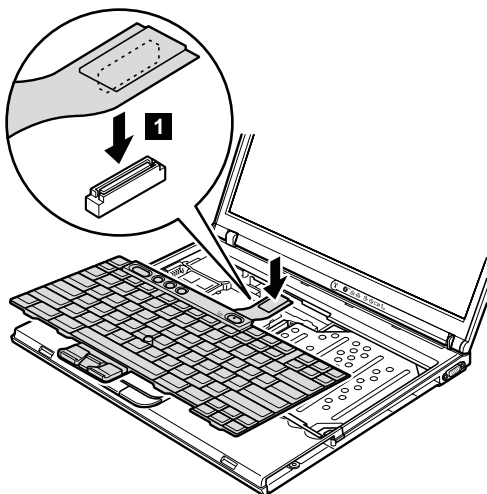

2. Make sure that the keyboard edges, marked **a** in the figure, are under the frame.

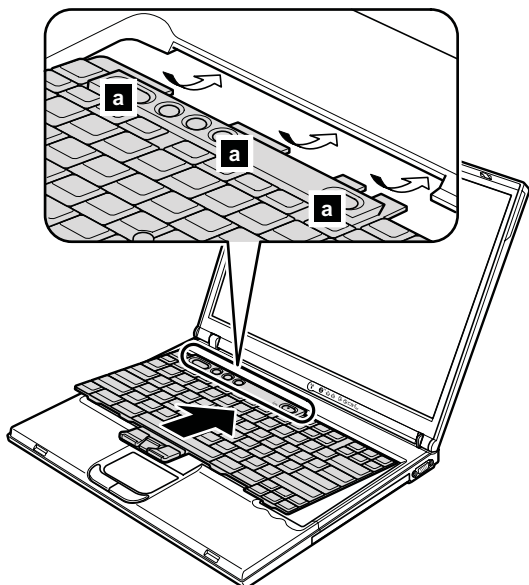

(continued)

3. To make sure that the front side of the keyboard is housed firmly, gently press the keys with your fingers and try to slide the keyboard towards you.



4. Make sure that all the projections on the front side of the keyboard **b** are firmly attached under the frame.

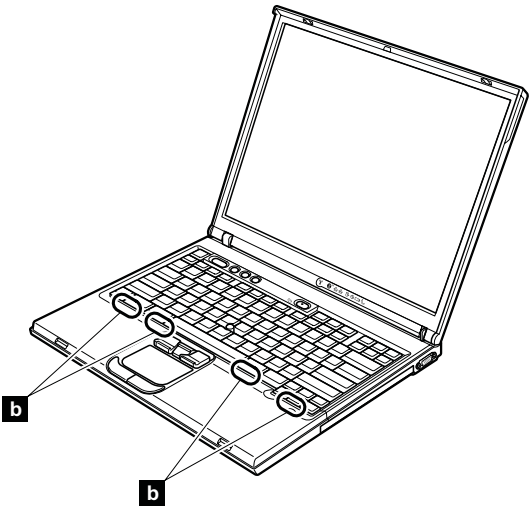

5. Secure the keyboard from the underside of the computer, using the new screws provided with the keyboard.

1070 DIMM (standard)

For access, remove these FRUs in order:

- “1010 Battery pack (14.1-in. LCD models)” on page 72
- “1020 Battery pack (15.0-in. LCD models)” on page 74
- “1060 Keyboard” on page 80

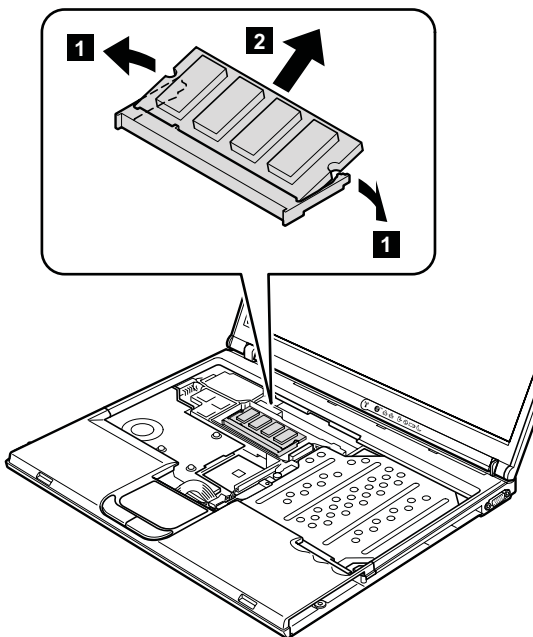

When installing: Insert the notched end of the DIMM into the socket. Press the DIMM firmly, and pivot it until it snaps into the place. Make sure that it is firmly fixed in the slot and does not move easily.

1080 Modem daughter card (MDC-2)

For access, remove these FRUs in order:

- “1010 Battery pack (14.1-in. LCD models)” on page 72
- “1020 Battery pack (15.0-in. LCD models)” on page 74
- “1060 Keyboard” on page 80

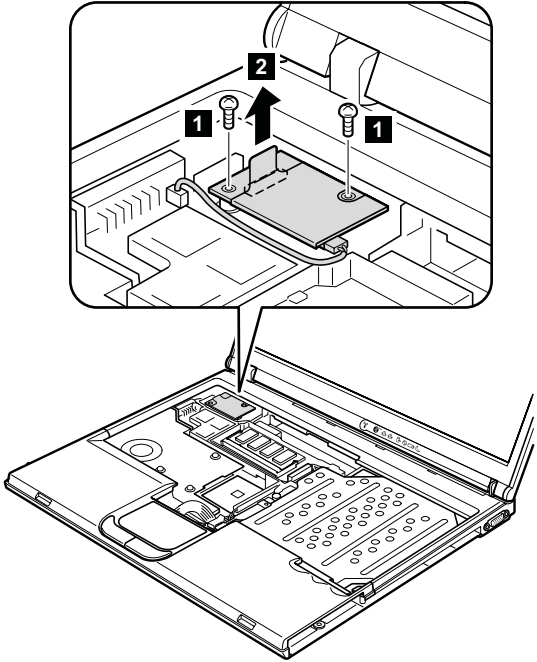

Step	Screw (quantity)	Color	Torque
1	M2 × 10 mm, flat-head, nylon-coated (2)	Black	0.245 Nm (2.5 kgfcm)

In step **2**, remove the card by pulling the tab with your fingers in the direction of the arrow.

(continued)

Removing and replacing a FRU

Turn the card over **3**, and detach the modem connector **4**.

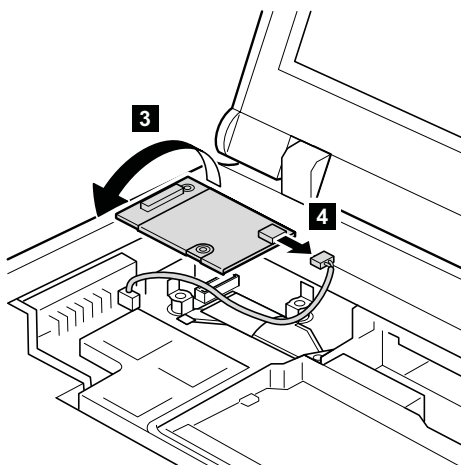

When installing: Make sure that connector **4** and the connector on the underside of the card are firmly attached.

1090 Bluetooth/Modem daughter card (BMDC-3)

For access, remove these FRUs in order:

- “1010 Battery pack (14.1-in. LCD models)” on page 72
- “1020 Battery pack (15.0-in. LCD models)” on page 74
- “1060 Keyboard” on page 80

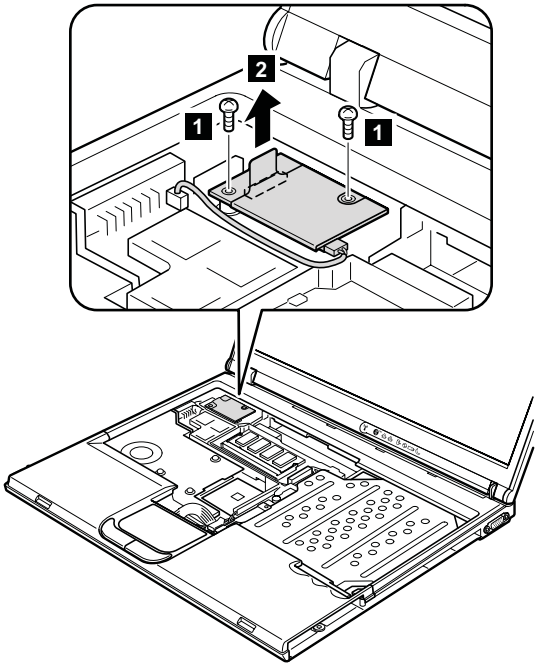

Step	Screw (quantity)	Color	Torque
1	M2 × 10 mm, flat-head, nylon-coated (2)	Black	0.245 Nm (2.5 kgfcm)

In step **2**, remove the card by pulling the tab with your fingers in the direction of the arrow.

(continued)

Removing and replacing a FRU

Turn the card over **3**, and detach the modem connector **4**. Then, unplug the jack by using the removal tool antenna RF connector (P/N: 08K7159) or pick the connector with your fingers and gently unplug it in direction of the arrow **5**.

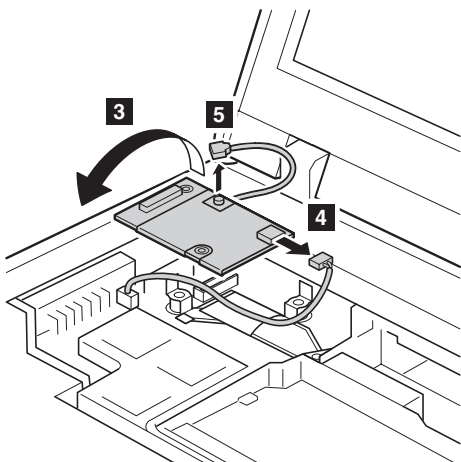

When installing: Make sure that connector **4**, the jack **5**, and the connector on the underside of the card are firmly attached.

1100 Palm rest or Palm rest with fingerprint reader (14.1-in. LCD models)

For access, remove these FRUs in order:

- “1010 Battery pack (14.1-in. LCD models)” on page 72
- “1040 Hard disk drive” on page 76
- “1060 Keyboard” on page 80

Notes

In models with the fingerprint reader, the sensor has been attached to the palm rest FRU as the child part. In case of the fingerprint reader has any defects and needs to be replaced, you need to replace the palm rest by following the procedures in this section. The procedures are same both for the palm rest without the fingerprint reader and for the palm rest with the fingerprint reader.

(continued)

Removing and replacing a FRU

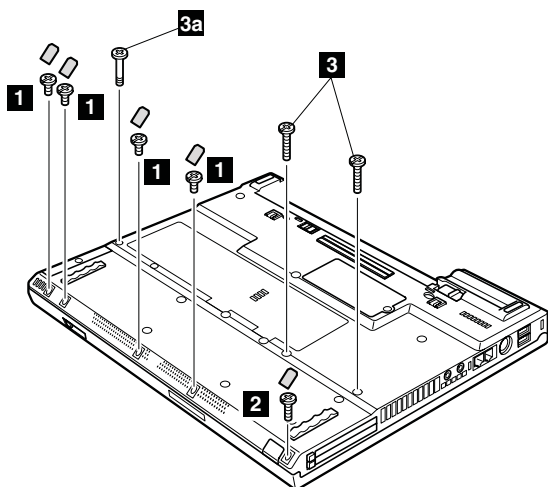

Step	Icon	Screw cap	Screw (quantity)	Color	Torque
1	 1		M2 × 4 mm, small-head, nylon-coated (4)	Black	0.245 Nm (2.5 kgfcm)
2	 2		M2 × 5 mm, bind-head, nylon-coated (1)	Silver	0.245 Nm (2.5 kgfcm)
3	 4	—	M2 × 14 mm, bind-head, nylon-coated (2)	Black	0.204 Nm (2.0 kgfcm)
3a	 4	—	Special screw (1)	Black	0.204 Nm (2.0 kgfcm)

(continued)

For a model with a touch pad, detach the touch pad connector by pulling the tab with your fingers in the direction of arrow **4**. Then remove the palm rest in the direction of arrow **5**. For other models, skip step **4**.

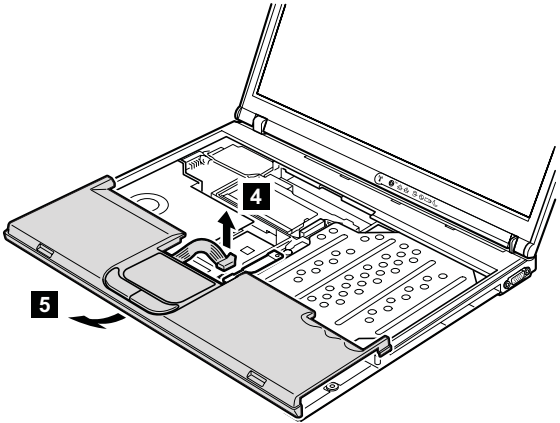

When installing: On a model with a touch pad, make sure that connector **4** is firmly attached.

1110 Keyboard bezel or Keyboard bezel with fingerprint reader (15.0-in. LCD models)

For access, remove these FRUs in order:

- “1020 Battery pack (15.0-in. LCD models)” on page 74
- “1040 Hard disk drive” on page 76
- “1060 Keyboard” on page 80

Note

In models with the fingerprint reader, the sensor has been attached to the keyboard bezel FRU as the child part. In case of the fingerprint reader has any defects and needs to be replaced, you need to replace the keyboard bezel by following the procedures in this section. The procedures are same both for the keyboard bezel without the fingerprint reader and for the keyboard bezel with the fingerprint reader.

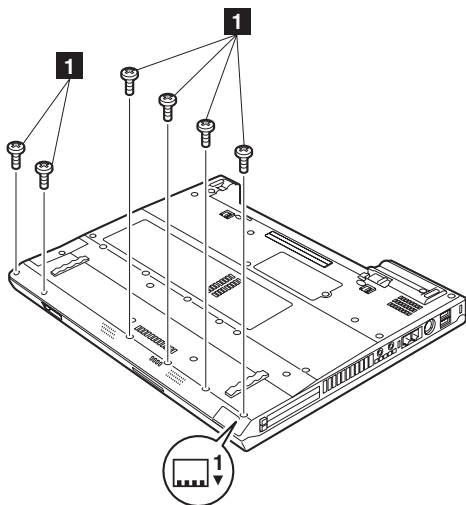

Step	Icon	Screw (quantity)	Color	Torque
1		M2 × 5 mm, flat-head, nylon-coated (6)	Black	0.245 Nm (2.5 kgfcm)

(continued)

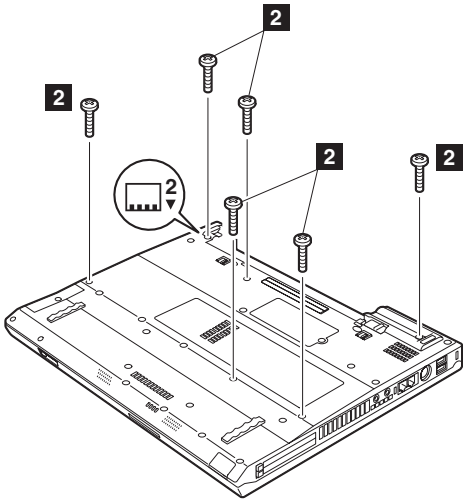

Step	Icon	Screw (quantity)	Color	Torque
2		M2 x 14 mm, bind-head, nylon-coated (6)	Black	0.245 Nm (2.5 kgfcm)

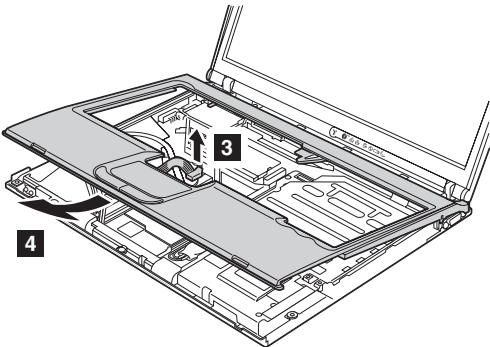

When installing:

1. Place the keyboard bezel so that the three latches are fixed in place **1**.

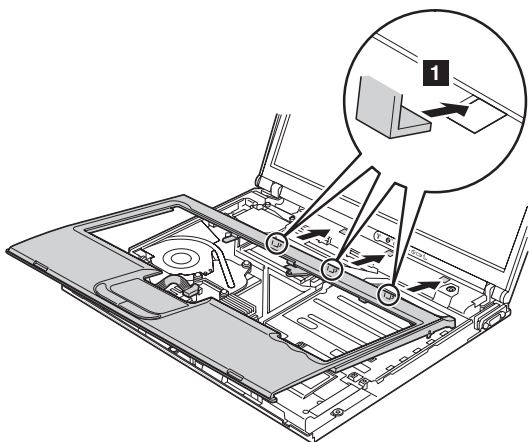

While inserting the three latches, align the top-left corner of the keyboard bezel as in figure **a**.

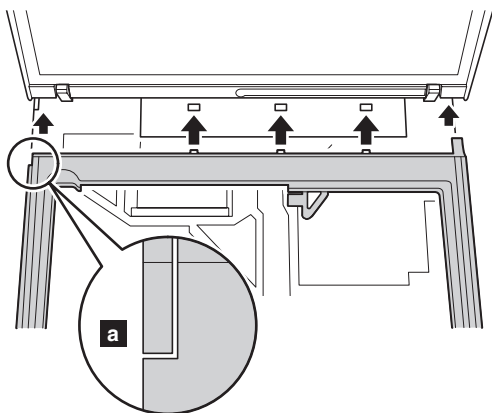

(continued)

2. Press the left edges **2** and the front edges **3** of the keyboard bezel until the latches are snapped.

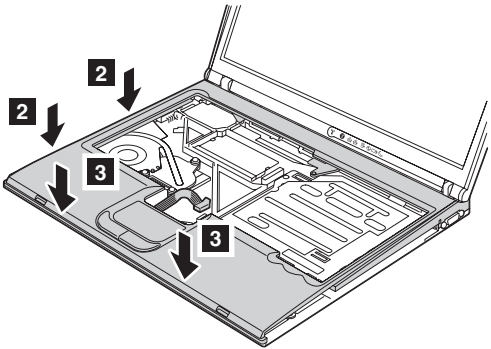

3. Attach the touch pad connector **4**.

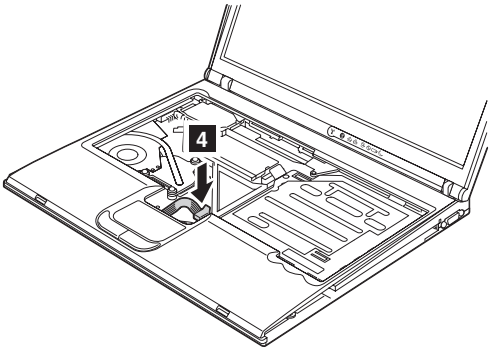

(continued)

Removing and replacing a FRU

4. Secure the keyboard bezel from the underside of the computer with the screws **b** and **c**.

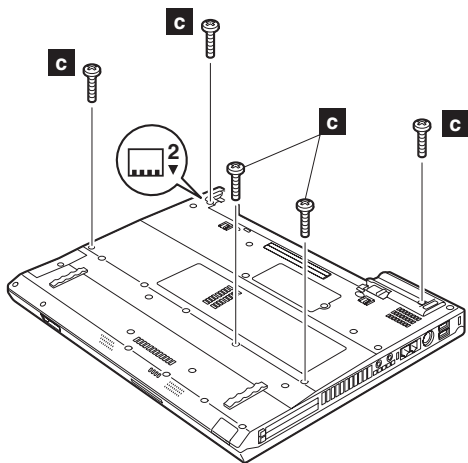
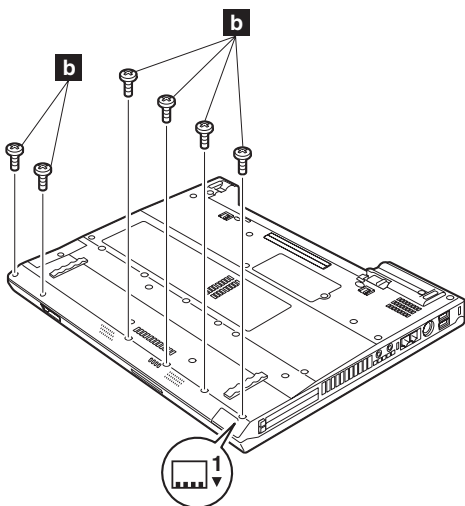

5. Attach the keyboard.
(continued)

- Secure the keyboard bezel from the underside of the computer with the screw **d**. This screw cannot be fastened properly without attaching keyboard.

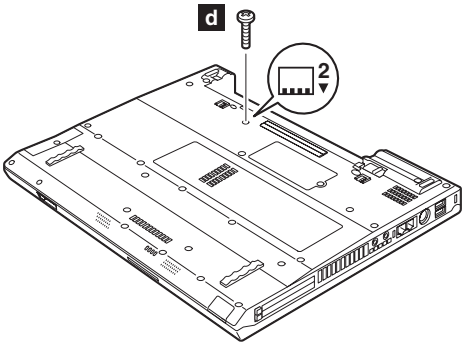

1120 Mini PCI adapter

For access, remove these FRUs in order:

- “1010 Battery pack (14.1-in. LCD models)” on page 72
- “1020 Battery pack (15.0-in. LCD models)” on page 74
- “1040 Hard disk drive” on page 76
- “1060 Keyboard” on page 80
- “1100 Palm rest or Palm rest with fingerprint reader (14.1-in. LCD models)” on page 89
- “1110 Keyboard bezel or Keyboard bezel with fingerprint reader (15.0-in. LCD models)” on page 92

Unplug the jacks by using the removal tool antenna RF connector (P/N: 08K7159) or pick the connectors with your fingers and gently unplug it in direction of the arrow **1** and **2**.

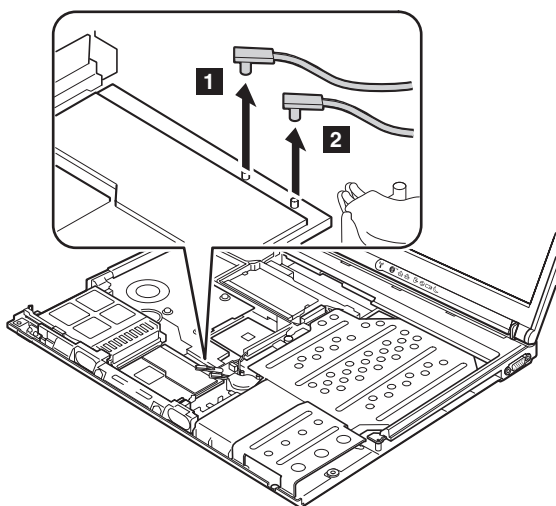

(continued)

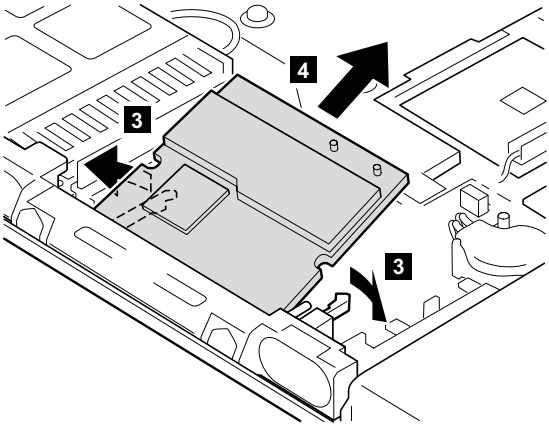

When installing:

1. Plug the gray cable to jack **M**, and the black cable to jack **A**.

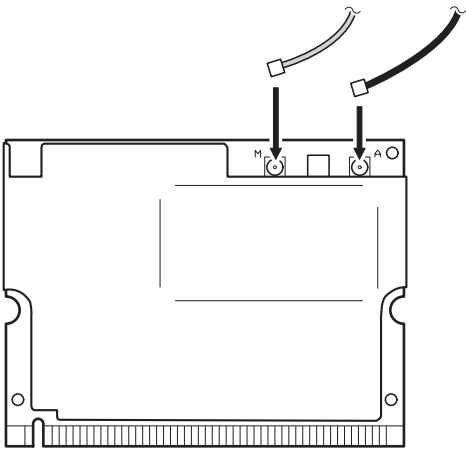

2. Insert the notched end of the card into the socket, and then press the card firmly. Pivot the card until it snaps into place. Make sure that it is firmly fixed in the slot and does not move easily.

1130 Fan assembly

For access, remove these FRUs in order:

- “1010 Battery pack (14.1-in. LCD models)” on page 72
- “1020 Battery pack (15.0-in. LCD models)” on page 74
- “1040 Hard disk drive” on page 76
- “1060 Keyboard” on page 80
- “1100 Palm rest or Palm rest with fingerprint reader (14.1-in. LCD models)” on page 89
- “1110 Keyboard bezel or Keyboard bezel with fingerprint reader (15.0-in. LCD models)” on page 92

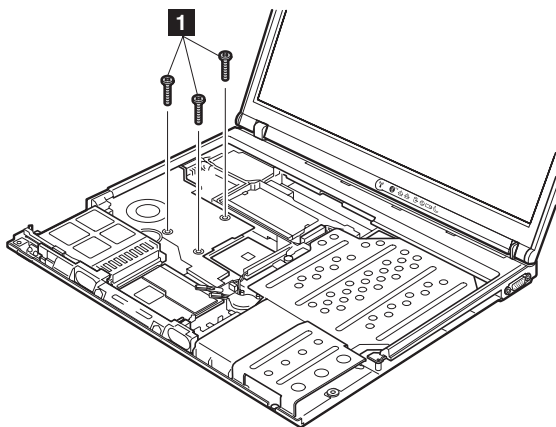

Step	Screw (quantity)	Color	Torque
1	M2 × 10 mm, flat-head, nylon-coated (3)	Black	0.245 Nm (2.5 kgfcm)

(continued)

Important

In step **2**, insert the tip of the tool horizontally between the fan assembly and the CPU, as indicated by arrow **a**. Then slightly push the tool into the gap until the fan assembly comes off. Do not move the tool upward or downward to remove the fan assembly between the gap. To do so, the CPU or the other electrical component may be damaged.

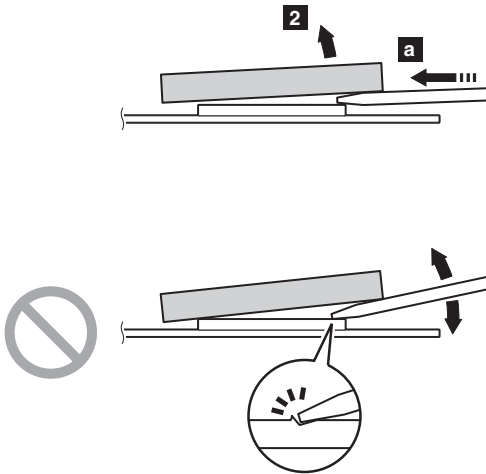

(continued)

Important

In step **2a** and **2b**, be careful not to damage the copper plate of the fan assembly. Step **2a** is for the fan assembly, long and for the fan assembly, long M10. Step **2b** is for the fan assembly, short.

Distortion of the fan assembly may cause a thermal problem.

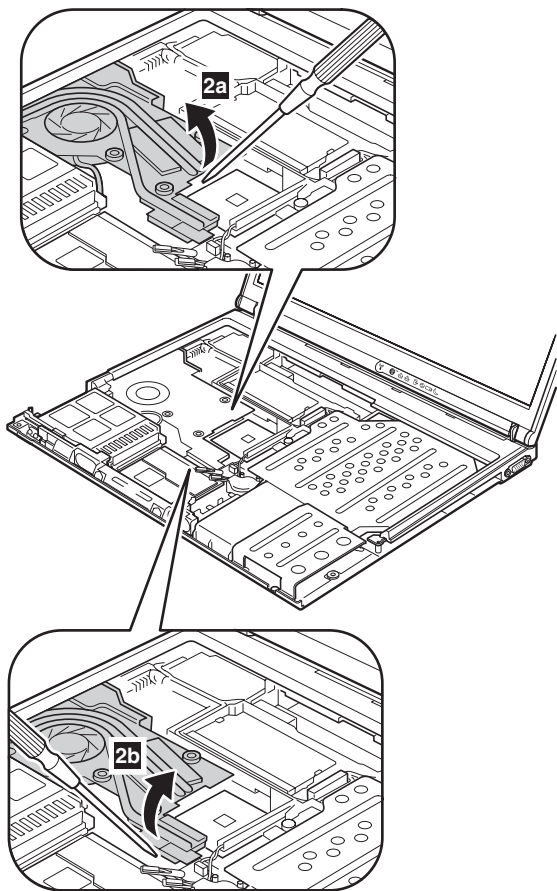

(continued)

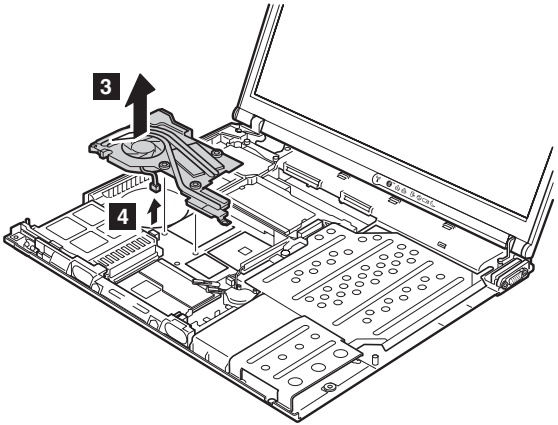

When installing:

- Before you attach the fan assembly to the computer, apply thermal grease on the part marked **a** as in the following figures.
- Make sure that the connector **4** is firmly attached.

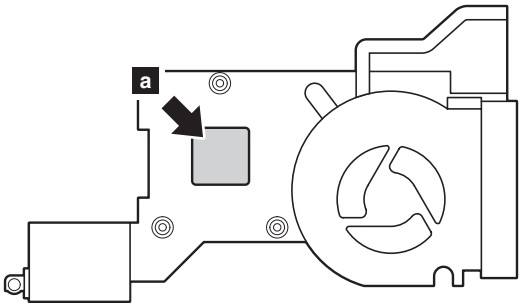

1140 Backup battery



Use only the battery specified in the parts list for your computer. Any other battery could ignite or explode.

For access, remove these FRUs in order:

- “1010 Battery pack (14.1-in. LCD models)” on page 72
- “1020 Battery pack (15.0-in. LCD models)” on page 74
- “1040 Hard disk drive” on page 76
- “1060 Keyboard” on page 80
- “1100 Palm rest or Palm rest with fingerprint reader (14.1-in. LCD models)” on page 89
- “1110 Keyboard bezel or Keyboard bezel with fingerprint reader (15.0-in. LCD models)” on page 92

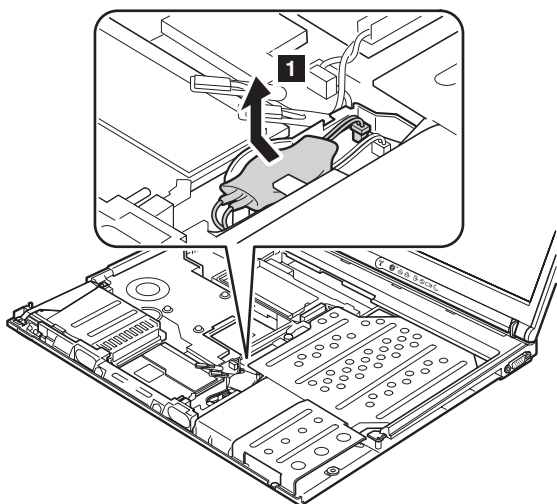

(continued)

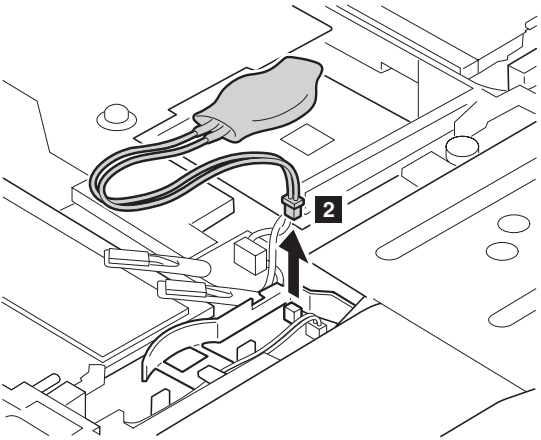

When installing: Make sure that the battery connector **2** is firmly attached.

1150 Speaker assembly

For access, remove these FRUs in order:

- “1010 Battery pack (14.1-in. LCD models)” on page 72
- “1020 Battery pack (15.0-in. LCD models)” on page 74
- “1040 Hard disk drive” on page 76
- “1060 Keyboard” on page 80
- “1100 Palm rest or Palm rest with fingerprint reader (14.1-in. LCD models)” on page 89
- “1110 Keyboard bezel or Keyboard bezel with fingerprint reader (15.0-in. LCD models)” on page 92

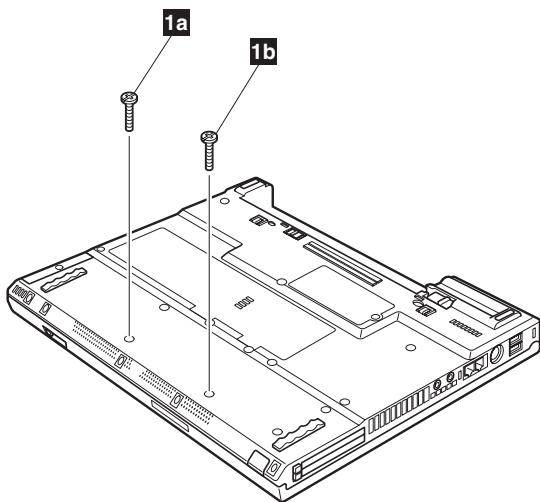

For 14.1-in. LCD models:

Step	Screw (quantity)	Color	Torque
1a	M2 × 10 mm, flat-head, nylon-coated (2)	Black	0.245 Nm (2.5 kgfcm)
1b			

For 15.0-in. LCD models:

Step	Screw (quantity)	Color	Torque
1a	M2 × 10 mm, bind-head, nylon-coated (1)	Black	0.245 Nm (2.5 kgfcm)
1b	M2 × 14 mm, flat-head, nylon-coated (1)	Black	0.245 Nm (2.5 kgfcm)

(continued)

In step **3** , release the speaker cables from the cable guide.

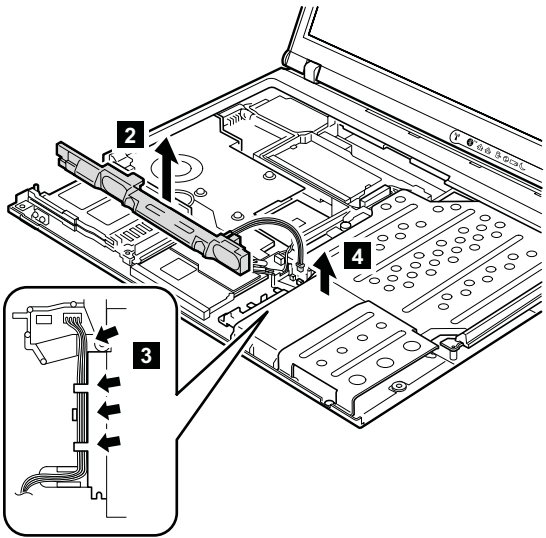

When installing: Make sure that the connector **4** is firmly attached. Then route the cable as in **3** .

1160 Keyboard bezel (14.1-in. LCD models)

For access, remove these FRUs in order:

- “1010 Battery pack (14.1-in. LCD models)” on page 72
- “1040 Hard disk drive” on page 76
- “1060 Keyboard” on page 80
- “1100 Palm rest or Palm rest with fingerprint reader (14.1-in. LCD models)” on page 89

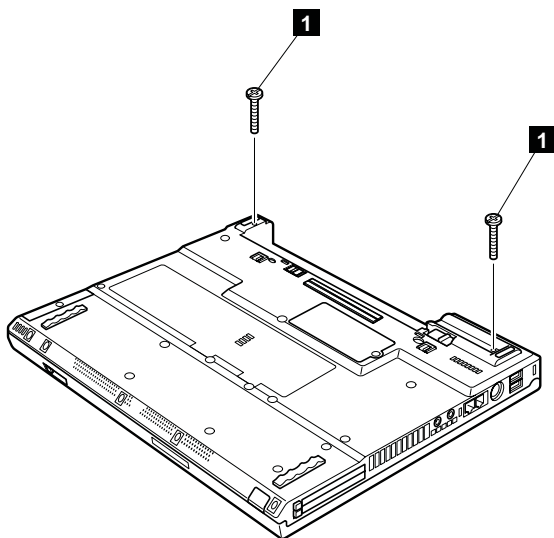

Step	Screw (quantity)	Color	Torque
1	M2 × 19 mm, bind-head, nylon-coated (2)	Black	0.245 Nm (2.5 kgfcm)

(continued)

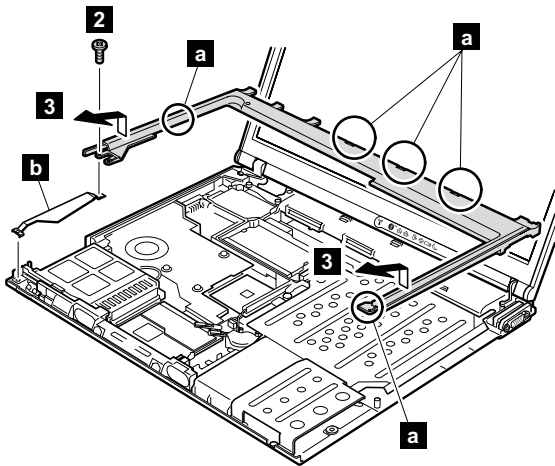

Step	Screw (quantity)	Color	Torque
2	M2 × 4 mm, bind-head, nylon-coated (1)	Black	0.245 Nm (2.5 kgfcm)

In step **3**, make sure that all the latches marked **a** are detached, and then remove the bezel.

When installing: Make sure that all the latches marked **a** are firmly attached. Attach harness left (**b**), and then secure the keyboard bezel with the screws.

1170 PC Card/ExpressCard slots (14.1-in. LCD models)

For access, remove these FRUs in order:

- “1010 Battery pack (14.1-in. LCD models)” on page 72
- “1040 Hard disk drive” on page 76
- “1060 Keyboard” on page 80
- “1100 Palm rest or Palm rest with fingerprint reader (14.1-in. LCD models)” on page 89
- “1150 Speaker assembly” on page 106
- “1160 Keyboard bezel (14.1-in. LCD models)” on page 108

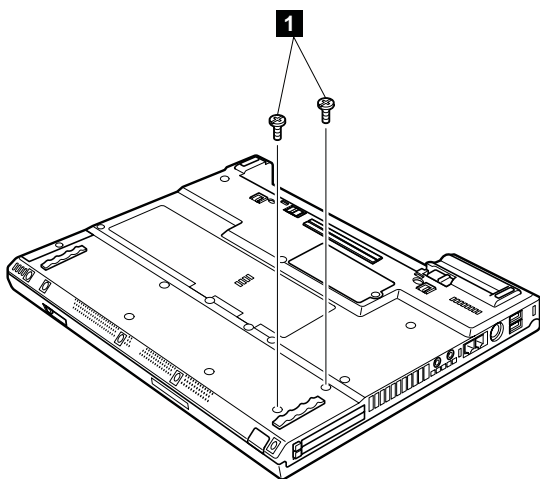

Step	Screw (quantity)	Color	Torque
1	M2 × 4 mm, bind-head, nylon-coated (2)	Black	0.204 Nm (2.0 kgfcm)

(continued)

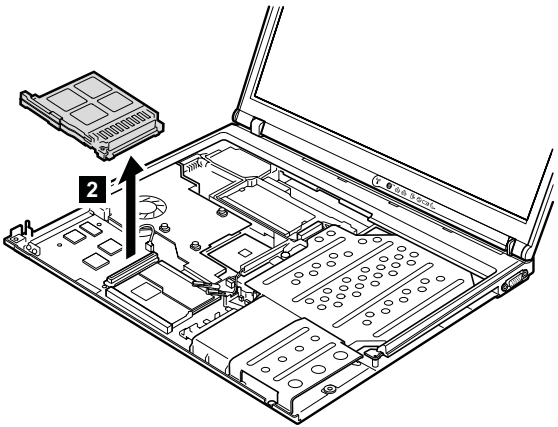

When installing: Make sure that the connector on the underside of the PC Card/ExpressCard slots **2** is firmly attached, and then secure the slots with the screws.

1180 PC Card/ExpressCard slots (15.0-in. LCD models)

For access, remove these FRUs in order:

- “1020 Battery pack (15.0-in. LCD models)” on page 74
- “1040 Hard disk drive” on page 76
- “1060 Keyboard” on page 80
- “1110 Keyboard bezel or Keyboard bezel with fingerprint reader (15.0-in. LCD models)” on page 92
- “1150 Speaker assembly” on page 106

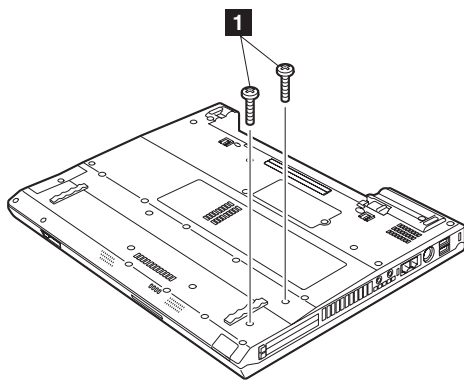

Step	Screw (quantity)	Color	Torque
1	M2 × 5 mm, flat-head, nylon-coated (2)	Black	0.204 Nm (2.0 kgfcm)

(continued)

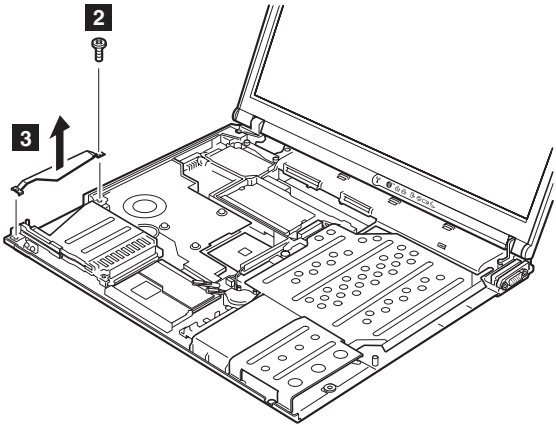

Step	Screw (quantity)	Color	Torque
2	M2 × 4 mm, bind-head, nylon-coated (1)	Black	0.245 Nm (2.5 kgfcm)

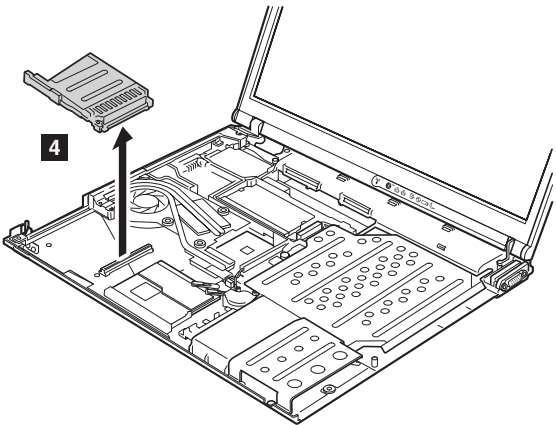

When installing: Make sure that the connector on the underside of the PC Card/ExpressCard slots **2** is firmly attached, and then secure the slots with the screws.

1190 LCD assembly (14.1-in. LCD models)

For access, remove these FRUs in order:

- “1010 Battery pack (14.1-in. LCD models)” on page 72
- “1040 Hard disk drive” on page 76
- “1060 Keyboard” on page 80
- “1090 **Bluetooth**/Modem daughter card (BMDC-3)” on page 87
- “1100 Palm rest or Palm rest with fingerprint reader (14.1-in. LCD models)” on page 89
- “1120 Mini PCI adapter” on page 98
- “1160 Keyboard bezel (14.1-in. LCD models)” on page 108

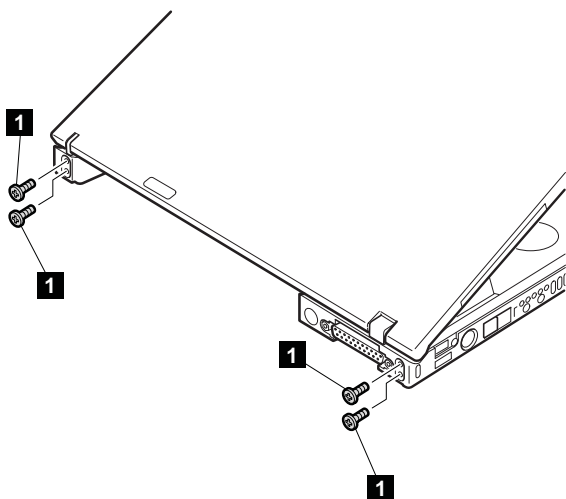

Step	Screw (quantity)	Color	Torque
1	M2.5 × 4.8 mm, bind-head, nylon-coated (4)	Black	0.392 Nm (4 kgfcm)

(continued)

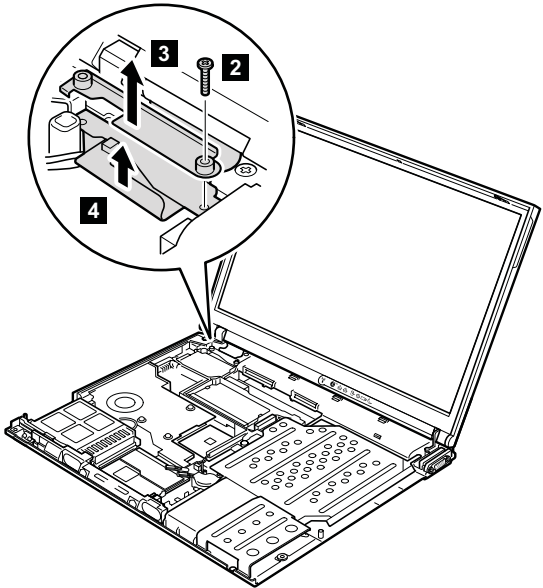

Step	Screw (quantity)	Color	Torque
2	M2 × 14 mm, bind-head, nylon-coated (1)	Black	0.245 Nm (2.5 kgfcm)

After removing the screw, remove bracket **3**. Then detach the LCD connector **4**.

When installing: Make sure that the bracket **3** and the connector **4** are firmly attached, and then secure them with the screw.

(continued)

Removing and replacing a FRU

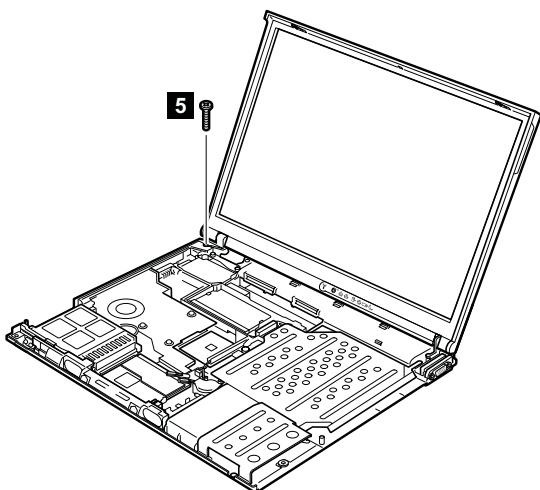

Step	Screw (quantity)	Color	Torque
5	M2 × 10 mm, flat-head, nylon-coated (1)	Black	0.245 Nm (2.5 kgfcm)

(continued)

Release the antenna cables from the cable guide **6**.

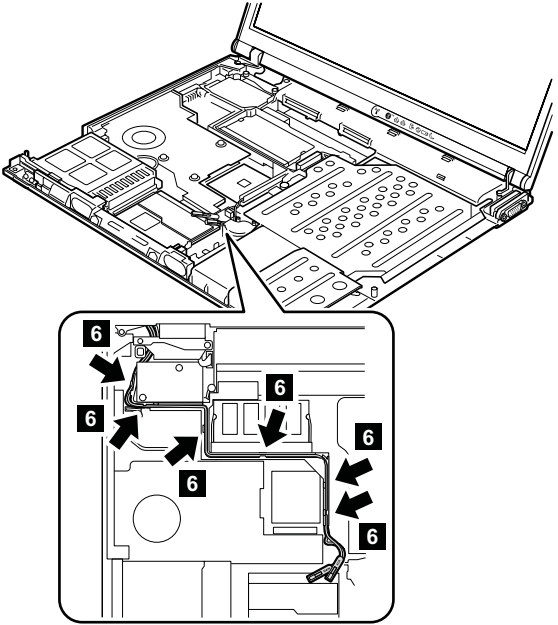

When installing: Make sure that the antenna cables are correctly routed and securely in place.

(continued)

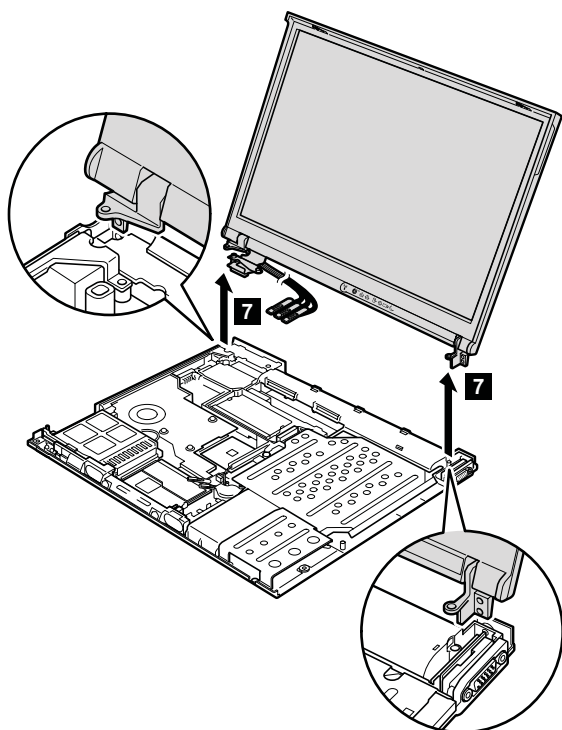

When installing: Make sure that the security keyhole which is on the left-rear corner of the base cover and the keyhole of the bracket inside are aligning firmly.

1200 LCD assembly (15.0-in. LCD models)

For access, remove these FRUs in order:

- “1020 Battery pack (15.0-in. LCD models)” on page 74
- “1040 Hard disk drive” on page 76
- “1060 Keyboard” on page 80
- “1090 **Bluetooth**/Modem daughter card (BMDC-3)” on page 87
- “1110 Keyboard bezel or Keyboard bezel with fingerprint reader (15.0-in. LCD models)” on page 92
- “1120 Mini PCI adapter” on page 98

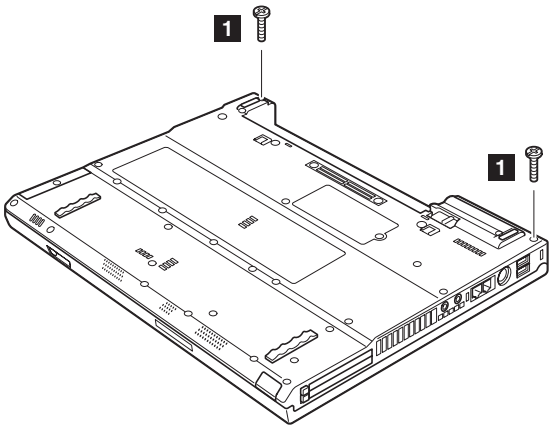

Step	Screw (quantity)	Color	Torque
1	M2 × 10 mm, flat-head, nylon-coated (2)	Black	0.245 Nm (2.5 kgfcm)

(continued)

Removing and replacing a FRU

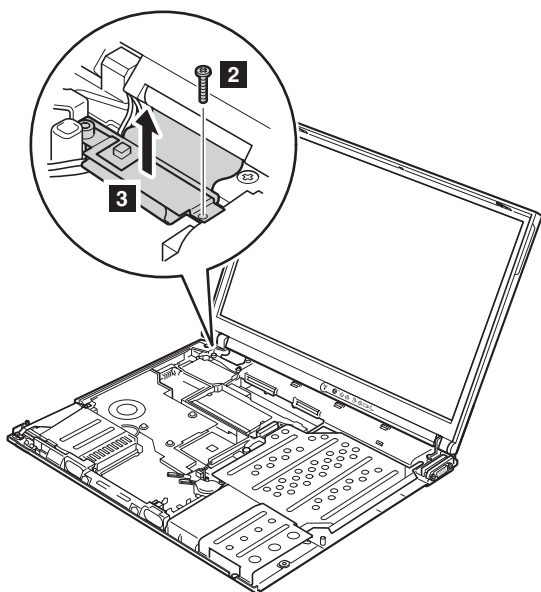

Step	Screw (quantity)	Color	Torque
2	M2 × 12 mm, flat-head, nylon-coated (1)	Black	0.245 Nm (2.5 kgfcm)

When installing: Make sure that the connector **3** is firmly attached, and then secure it with the screw.

(continued)

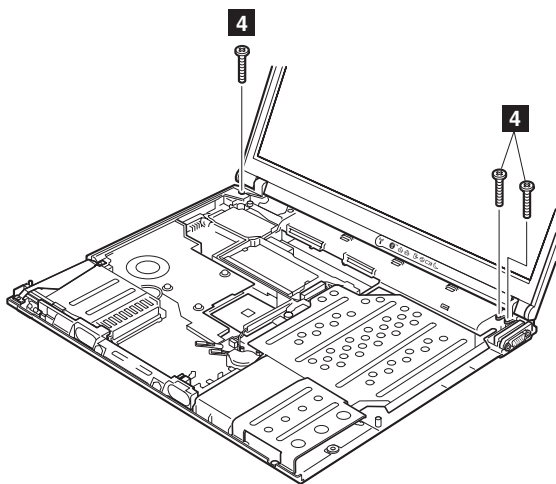

Step	Screw (quantity)	Color	Torque
4	M2 × 10 mm, flat-head, nylon-coated (3)	Black	0.245 Nm (2.5 kgfcm)

(continued)

Removing and replacing a FRU

Release the antenna cables from the cable guide **5**.

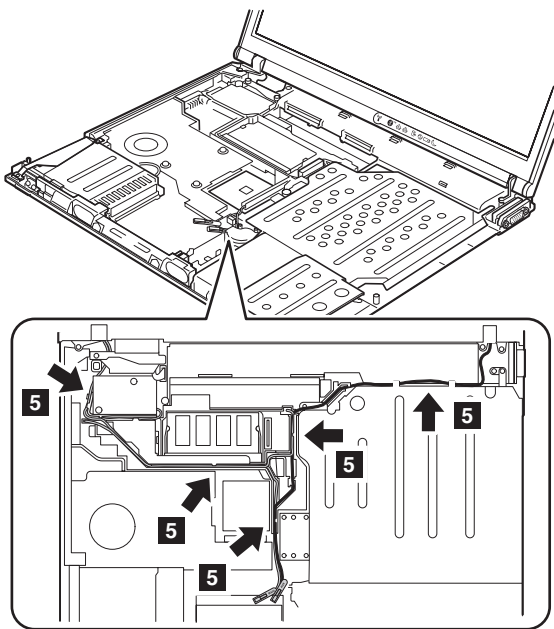

When installing: Make sure that the antenna cables are correctly routed and securely in place.

(continued)

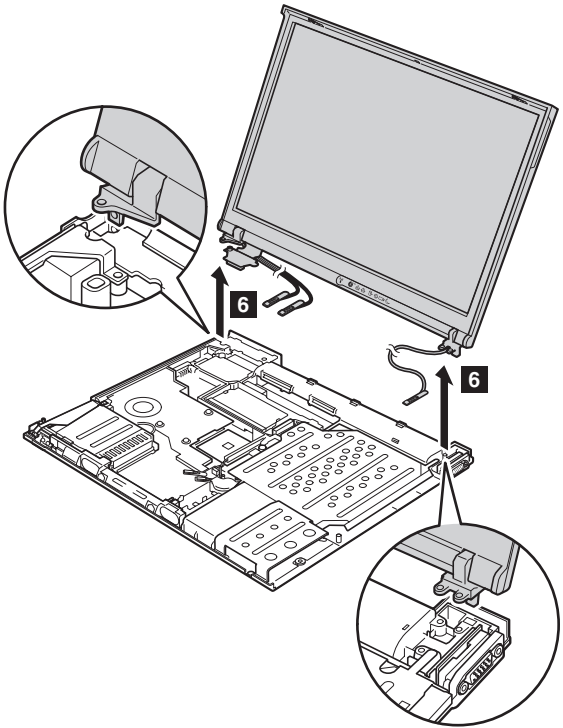

When installing: Make sure that the security keyhole which is on the left-rear corner of the base cover and the keyhole of the bracket inside are aligning firmly.

1210 CPU

For access, remove these FRUs in order:

- “1010 Battery pack (14.1-in. LCD models)” on page 72
- “1040 Hard disk drive” on page 76
- “1060 Keyboard” on page 80
- “1100 Palm rest or Palm rest with fingerprint reader (14.1-in. LCD models)” on page 89
- “1110 Keyboard bezel or Keyboard bezel with fingerprint reader (15.0-in. LCD models)” on page 92
- “1160 Keyboard bezel (14.1-in. LCD models)” on page 108
- “1190 LCD assembly (14.1-in. LCD models)” on page 114
- “1130 Fan assembly” on page 100

Rotate the head of the screw in the direction shown by arrow **1** to release the lock; then remove the CPU **2**.

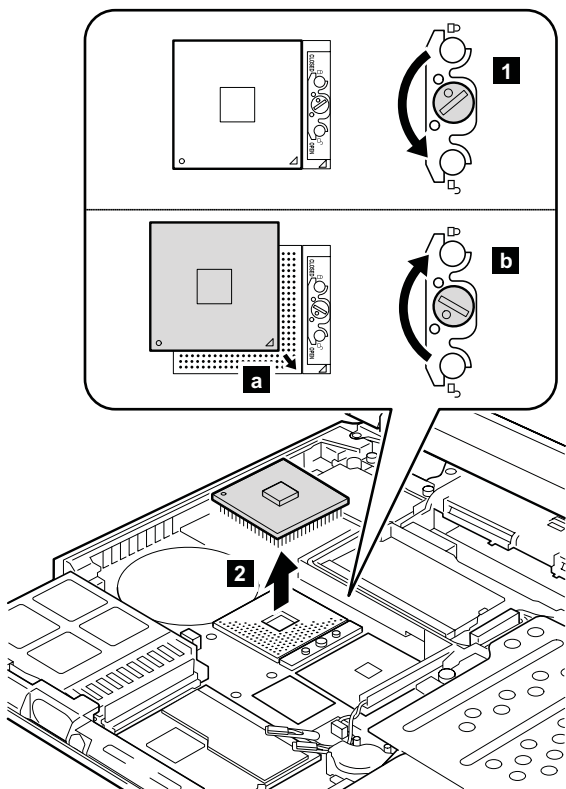

When installing: Place the CPU on the CPU socket **a**, and then rotate the head of the screw in the direction shown by arrow **b** to secure the CPU.

1220 Ultrabay Slim guide rail assembly (14.1-in. LCD models)

For access, remove these FRUs in order:

- “1010 Battery pack (14.1-in. LCD models)” on page 72
- “1040 Hard disk drive” on page 76
- “1060 Keyboard” on page 80
- “1100 Palm rest or Palm rest with fingerprint reader (14.1-in. LCD models)” on page 89
- “1150 Speaker assembly” on page 106
- “1160 Keyboard bezel (14.1-in. LCD models)” on page 108
- “1170 PC Card/ExpressCard slots (14.1-in. LCD models)” on page 110
- “1190 LCD assembly (14.1-in. LCD models)” on page 114

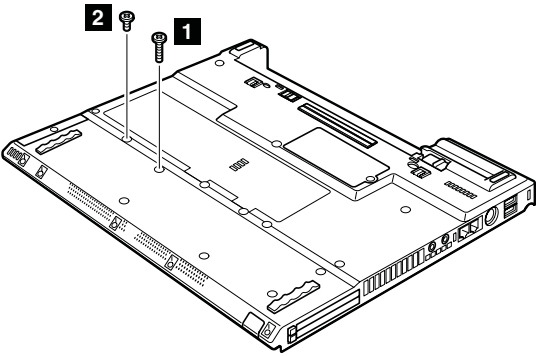

Step	Screw (quantity)	Color	Torque
1	M2 × 14 mm, bind-head, nylon-coated (1)	Black	0.204 Nm (2.0 kgfcm)
2	M2 × 4 mm, bind-head, nylon-coated (1)	Black	0.204 Nm (2.0 kgfcm)

(continued)

Removing and replacing a FRU

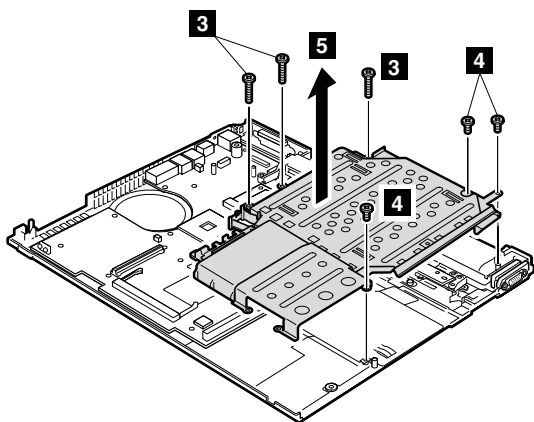

Step	Screw (quantity)	Color	Torque
3	M2 × 10 mm, flat-head, nylon-coated (3)	Black	0.245 Nm (2.5 kgfcm)
4	M2 × 3 mm, small-head, nylon-coated (3)	Silver	0.245 Nm (2.5 kgfcm)

In step **5**, remove the Ultrabay Slim guide rail assembly and the hard disk drive guide rail together.

Separate the Ultrabay Slim guide rail assembly **a** and the hard disk drive guide rail **b**.

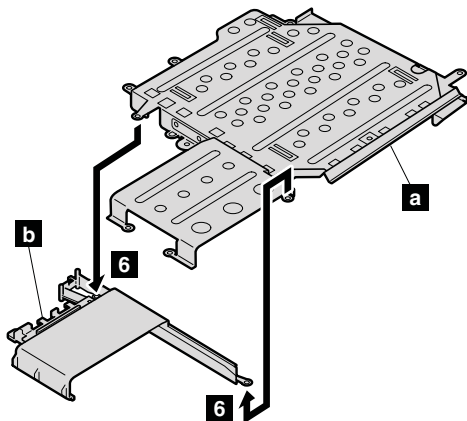

1230 Ultrabay Slim guide rail assembly (15.0-in. LCD models)

For access, remove these FRUs in order:

- “1020 Battery pack (15.0-in. LCD models)” on page 74
- “1040 Hard disk drive” on page 76
- “1060 Keyboard” on page 80
- “1110 Keyboard bezel or Keyboard bezel with fingerprint reader (15.0-in. LCD models)” on page 92
- “1150 Speaker assembly” on page 106

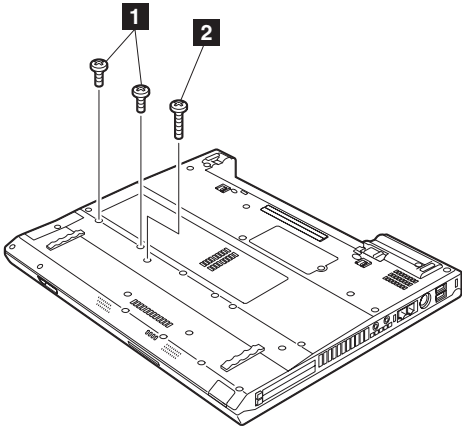

Step	Screw (quantity)	Color	Torque
1	M2 × 5 mm, flat-head, nylon-coated (2)	Black	0.204 Nm (2.0 kgfcm)
2	M2 × 14 mm, bind-head, nylon-coated (1)	Black	0.204 Nm (2.0 kgfcm)

(continued)

Removing and replacing a FRU

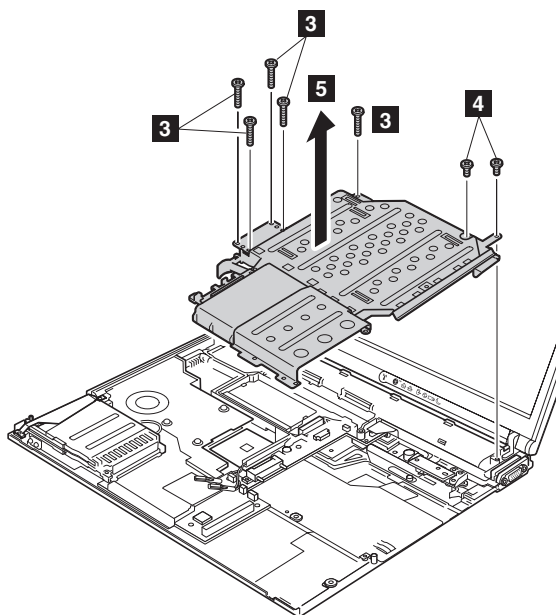

Step	Screw (quantity)	Color	Torque
3	M2 × 10 mm, flat-head, nylon-coated (5)	Black	0.245 Nm (2.5 kgfcm)
4	M2 × 3 mm, small-head, nylon-coated (2)	Black	0.245 Nm (2.5 kgfcm)

In step **5**, remove the Ultrabay Slim guide rail assembly and the hard disk drive guide rail together.

(continued)

Separate the Ultrabay Slim guide rail assembly **a** and the hard disk drive guide rail **b**.

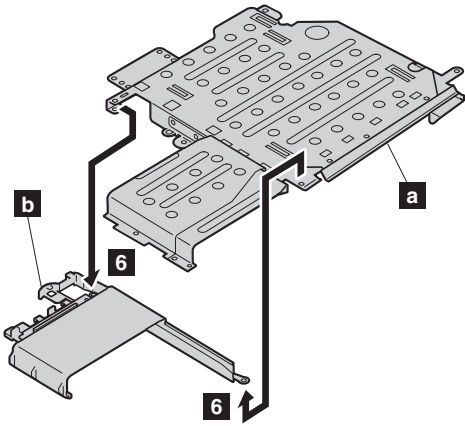

1240 VGA and Ultrabay Slim device eject button cable

For access, remove these FRUs in order:

- “1010 Battery pack (14.1-in. LCD models)” on page 72
- “1020 Battery pack (15.0-in. LCD models)” on page 74
- “1040 Hard disk drive” on page 76
- “1060 Keyboard” on page 80
- “1100 Palm rest or Palm rest with fingerprint reader (14.1-in. LCD models)” on page 89
- “1110 Keyboard bezel or Keyboard bezel with fingerprint reader (15.0-in. LCD models)” on page 92
- “1160 Keyboard bezel (14.1-in. LCD models)” on page 108
- “1190 LCD assembly (14.1-in. LCD models)” on page 114
- “1200 LCD assembly (15.0-in. LCD models)” on page 119
- “1220 Ultrabay Slim guide rail assembly (14.1-in. LCD models)” on page 125
- “1230 Ultrabay Slim guide rail assembly (15.0-in. LCD models)” on page 127

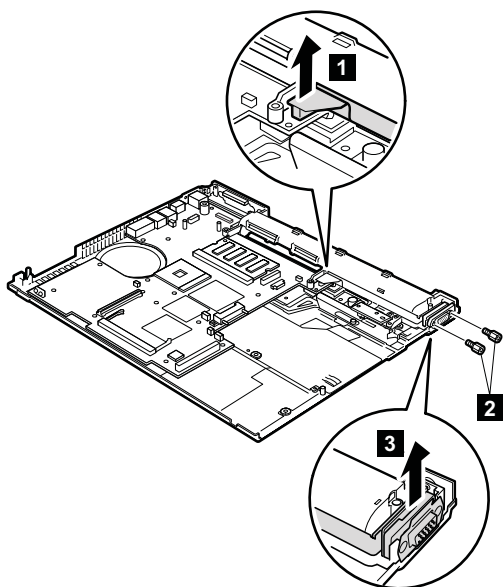

Step	Screw (quantity)	Color	Torque
2	Hex stud (2)	Silver	0.392 Nm (4 kgfcm)

(continued)

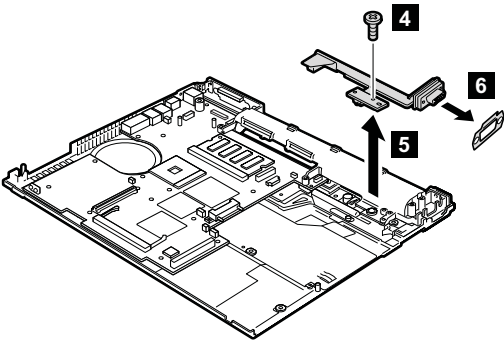

Step	Screw (quantity)	Color	Torque
4	M2 × 4 mm, bind-head, nylon-coated (1)	Black	0.245 Nm (2.5 kgfcm)

When installing: Make sure that the connector **1** is firmly attached.

1250 System board and base cover (14.1-in. LCD models)

For access, remove these FRUs, in order:

- “1010 Battery pack (14.1-in. LCD models)” on page 72
- “1030 Ultrabay Slim device” on page 75
- “1040 Hard disk drive” on page 76
- “1050 DIMM (optional)” on page 78
- “1060 Keyboard” on page 80
- “1070 DIMM (standard)” on page 84
- “1080 Modem daughter card (MDC-2)” on page 85
- “1090 **Bluetooth**/Modem daughter card (BMDC-3)” on page 87
- “1100 Palm rest or Palm rest with fingerprint reader (14.1-in. LCD models)” on page 89
- “1120 Mini PCI adapter” on page 98
- “1130 Fan assembly” on page 100
- “1140 Backup battery” on page 104
- “1150 Speaker assembly” on page 106
- “1160 Keyboard bezel (14.1-in. LCD models)” on page 108
- “1170 PC Card/ExpressCard slots (14.1-in. LCD models)” on page 110
- “1190 LCD assembly (14.1-in. LCD models)” on page 114
- “1210 CPU” on page 124
- “1220 Ultrabay Slim guide rail assembly (14.1-in. LCD models)” on page 125
- “1240 VGA and Ultrabay Slim device eject button cable” on page 130

Important notice for handling the system board:

The security chip **a** is soldered on the underside of the system board as in this figure.

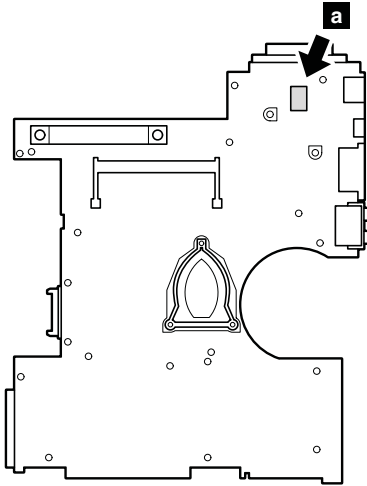

The accelerometer chip for the HDD Active Protection System **b** is also soldered on the topside of the system board.

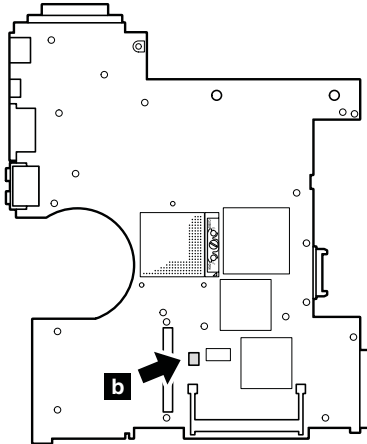

Important

When handling the system board, bear the following in mind.

- The system board has an accelerometer, which can be broken by applying several thousands of G-forces.

Note: Dropping a system board from a height of as little as 6 inches so that it falls flat on a hard bench can subject the accelerometer to as much as 6,000 G's of shock.

- Be careful not to drop the system board on a bench top that has a hard surface, such as metal, wood, or composite.
- If a system board is dropped, you must test it, using PC-Doctor for DOS, to make sure that the HDD Active Protection still functions (see below).

Note: If the test shows that HDD Active Protection is not functioning, be sure to document the drop in any reject report, and replace the system board.

- Avoid rough handling of any kind.
- At every point in the process, be sure not to drop or stack the system board.
- If you put a system board down, be sure to put it only on a padded surface such as an ESD mat or conductive corrugated material.

After replacing the system board, run PC-Doctor for DOS to make sure that HDD Active Protection still functions. The procedure is as follows:

1. Place the computer on a horizontal surface.
2. Run **Diagnostics --> Other Devices --> HDD Active Protection Test.**

Attention: Do not apply physical shock to the computer while the test is running.

Before removing the system board, remove the support structure (**a**) and the cable guide (**b**).

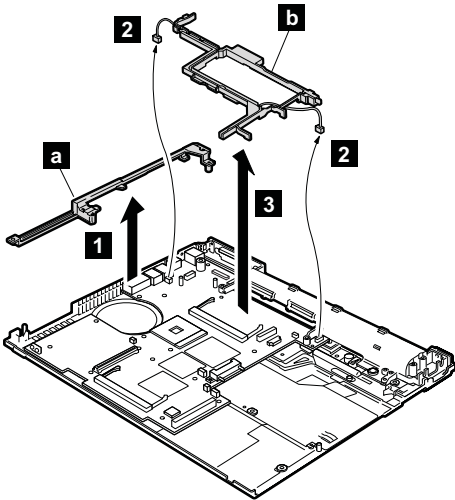

When installing: Make sure that the connectors **2** are firmly attached to the system board.

Removing and replacing a FRU

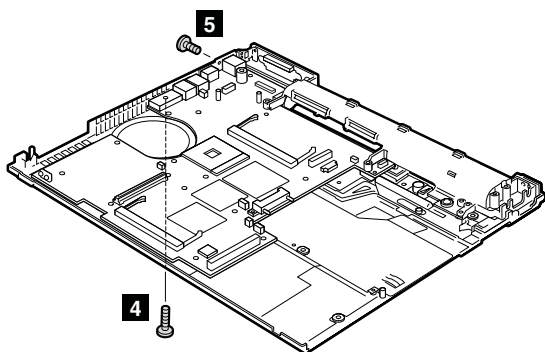

Step	Screw (quantity)	Color	Torque
4	M2 × 10 mm, flat-head, nylon-coated (1)	Black	0.245 Nm (2.5 kgfcm)
5	M2.5 × 4 mm, blind-head, nylon-coated (1)	Black	0.392 Nm (4 kgfcm)

(continued)

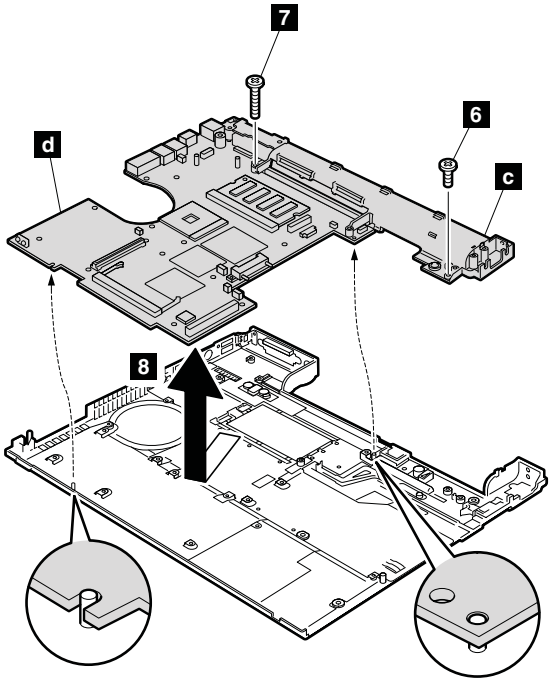

Step	Screw (quantity)	Color	Torque
6	M2 × 3 mm, small-head, nylon-coated (1)	Silver	0.245 Nm (2.5 kgfcm)
7	M2 × 10 mm, flat-head, nylon-coated (1)	Black	0.245 Nm (2.5 kgfcm)

In step **8**, remove the I/O plate bracket (**c**) and the system board (**d**) together.

(continued)

Removing and replacing a FRU

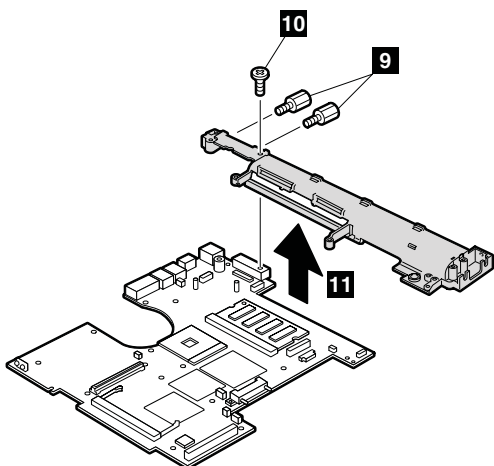

Step	Screw (quantity)	Color	Torque
9	Hex stud (2)	Silver	0.392 Nm (4 kgfcm)
10	M2.5 × 3 mm, bind-head, nylon-coated (1)	Gold	0.392 Nm (4 kgfcm)

When installing: Attach the system board so that the two small projections on the base cover fit into the holes provided, and then secure the system board with the screw.

Note for sticking a label kit on the base cover

New base cover FRU is shipped with several kinds of label kit. When you replace the base cover, you need to stick a homologation label **a** which has the same part no. with the label on the old base cover (defective FRU) on the new base cover.

In some models, you also need to stick one or two FCC labels **b**. Check the old base cover and if there is one or two FCC labels on it, find the same one from the label kit and stick it on the new base cover.

Stick the labels on the new base cover as shown in this figure.

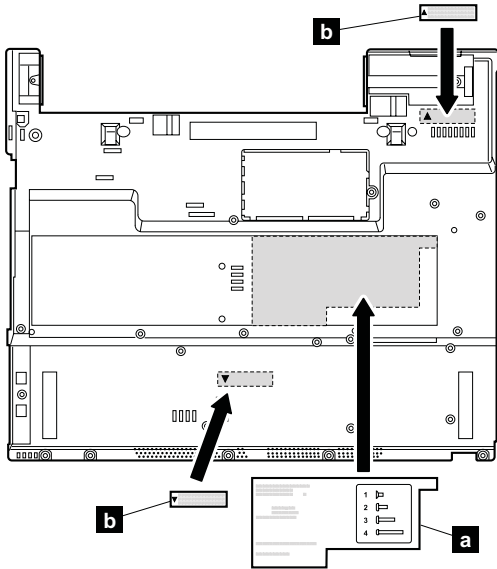

1260 System board, interposer card, and base cover (15.0-in. LCD models)

For access, remove these FRUs, in order:

- “1020 Battery pack (15.0-in. LCD models)” on page 74
- “1030 Ultrabay Slim device” on page 75
- “1040 Hard disk drive” on page 76
- “1050 DIMM (optional)” on page 78
- “1060 Keyboard” on page 80
- “1070 DIMM (standard)” on page 84
- “1080 Modem daughter card (MDC-2)” on page 85
- “1090 **Bluetooth**/Modem daughter card (BMDC-3)” on page 87
- “1110 Keyboard bezel or Keyboard bezel with fingerprint reader (15.0-in. LCD models)” on page 92
- “1120 Mini PCI adapter” on page 98
- “1130 Fan assembly” on page 100
- “1140 Backup battery” on page 104
- “1150 Speaker assembly” on page 106
- “1180 PC Card/ExpressCard slots (15.0-in. LCD models)” on page 112
- “1200 LCD assembly (15.0-in. LCD models)” on page 119
- “1210 CPU” on page 124
- “1230 Ultrabay Slim guide rail assembly (15.0-in. LCD models)” on page 127
- “1240 VGA and Ultrabay Slim device eject button cable” on page 130

Important notice for handling the system board:

The security chip **a** is soldered on the underside of the system board as in this figure.

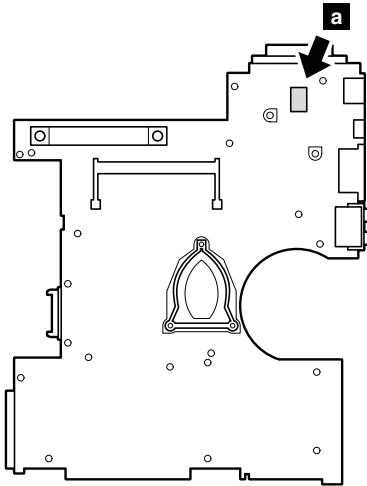

The accelerometer chip for the HDD Active Protection System **b** is also soldered on the topside of the system board.

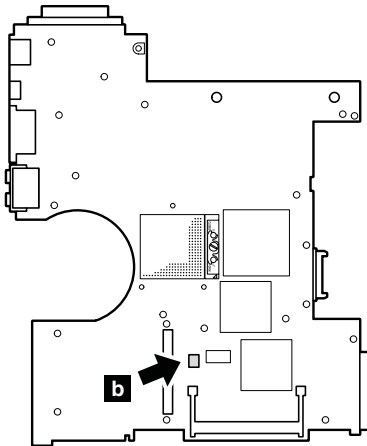

Important

When handling the system board, bear the following in mind.

- The system board has an accelerometer, which can be broken by applying several thousands of G-forces.

Note: Dropping a system board from a height of as little as 6 inches so that it falls flat on a hard bench can subject the accelerometer to as much as 6,000 G's of shock.

- Be careful not to drop the system board on a bench top that has a hard surface, such as metal, wood, or composite.
- If a system board is dropped, you must test it, using PC-Doctor for DOS, to make sure that the HDD Active Protection still functions (see below).

Note: If the test shows that HDD Active Protection is not functioning, be sure to document the drop in any reject report, and replace the system board.

- Avoid rough handling of any kind.
- At every point in the process, be sure not to drop or stack the system board.
- If you put a system board down, be sure to put it only on a padded surface such as an ESD mat or conductive corrugated material.

After replacing the system board, run PC-Doctor for DOS to make sure that HDD Active Protection still functions. The procedure is as follows:

1. Place the computer on a horizontal surface.
2. Run **Diagnostics --> Other Devices --> HDD Active Protection Test.**

Attention: Do not apply physical shock to the computer while the test is running.

Remove the support structure **a** and the EMI bracket **b**.

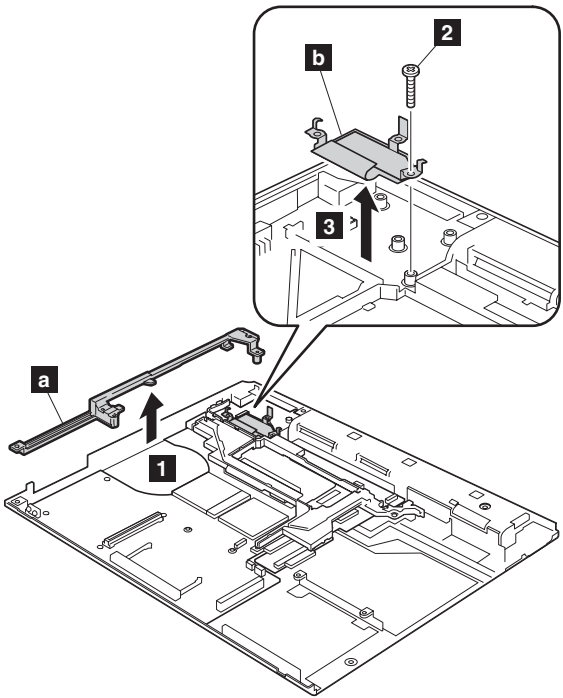

Step	Screw (quantity)	Color	Torque
2	M2 × 10 mm, flat-head, nylon-coated (1)	Black	0.245 Nm (2.5 kgfcm)

(continued)

Removing and replacing a FRU

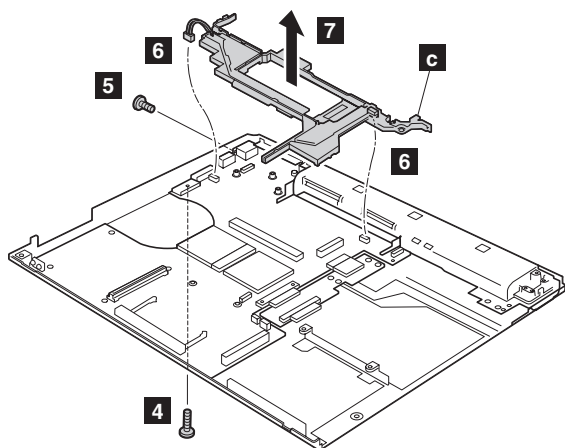

Step	Screw (quantity)	Color	Torque
4	M2 × 10 mm, flat-head, nylon-coated (1)	Black	0.245 Nm (2.5 kgfcm)
5	M2.5 × 4.8 mm, bind-head, nylon-coated (1)	Black	0.392 Nm (4 kgfcm)

Remove two connectors **6** and then remove the cable guide **c** in the direction of arrow **7**.

When installing: Make sure that the connectors **6** are firmly attached to the system board.

(continued)

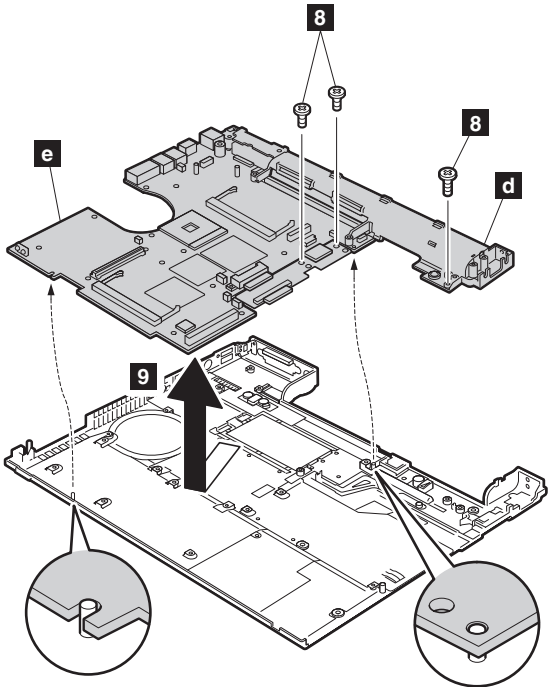

Step	Screw (quantity)	Color	Torque
8	M2 × 4 mm, bind-head, nylon-coated (3)	Black	0.245 Nm (2.5 kgfcm)

In step 9, remove the I/O plate bracket (d) and the system board (e) together.

When installing: Attach the system board so that the two small projections on the base cover fit into the holes provided, and then secure the system board with the screw.

(continued)

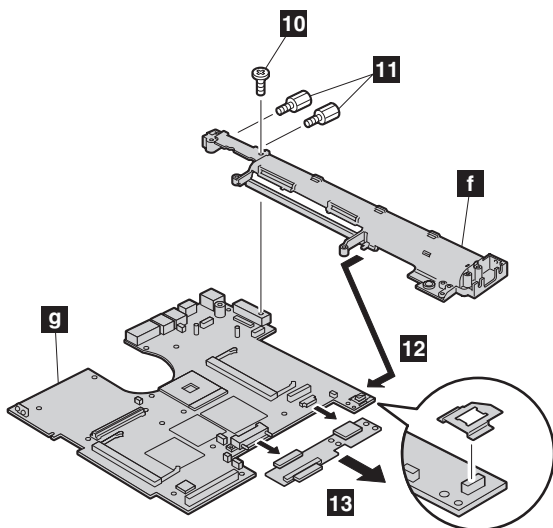

Step	Screw (quantity)	Color	Torque
10	Hex stud (2)	Silver	0.392 Nm (4 kgfcm)
11	M2.5 × 3 mm, flat-head, nylon-coated (1)	Gold	0.392 Nm (4 kgfcm)

Remove the system board **g** from the I/O plate bracket **f** in the direction of arrow **12**. Then remove the interposer card **13**.

When installing: Make sure that the connectors of the interposer card are firmly attached to the system board.

Note for sticking a label kit on the base cover

New base cover FRU is shipped with several kinds of label kit. When you replace the base cover, you need to stick a homologation label **a** which has the same part no. with the label on the old base cover (defective FRU) on the new base cover.

In some models, you also need to stick one or two FCC labels **b**. Check the old base cover and if there is one or two FCC labels on it, find the same one from the label kit and stick it on the new base cover.

Stick the labels on the new base cover as shown in this figure.

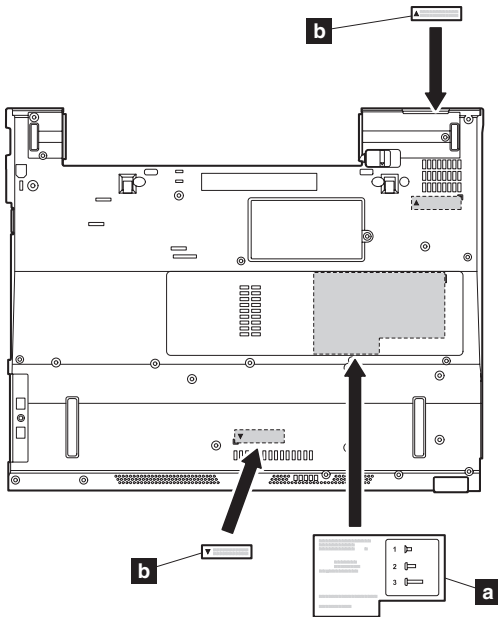



2010 LCD front bezel (14.1-in. LCD models)

For access, remove these FRUs in order:

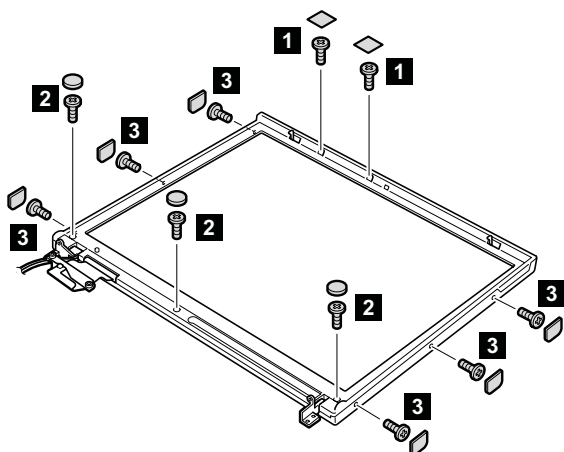
- “1010 Battery pack (14.1-in. LCD models)” on page 72
- “1040 Hard disk drive” on page 76
- “1060 Keyboard” on page 80
- “1090 **Bluetooth**/Modem daughter card (BMDC-3)” on page 87
- “1100 Palm rest or Palm rest with fingerprint reader (14.1-in. LCD models)” on page 89
- “1120 Mini PCI adapter” on page 98
- “1160 Keyboard bezel (14.1-in. LCD models)” on page 108
- “1190 LCD assembly (14.1-in. LCD models)” on page 114



Step	Screw cap	Screw (quantity)	Color	Torque
1		M2 × 3 mm, pan-head, nylon-coated (2)	Black	0.245 Nm (2.5 kgfcm)
2		M2.5 × 4.8 mm, bind-head, nylon-coated (3)	Black	0.392 Nm (4 kgfcm)
3		M2 × 3 mm, pan-head, nylon-coated (6)	Black	0.245 Nm (2.5 kgfcm)

(continued)

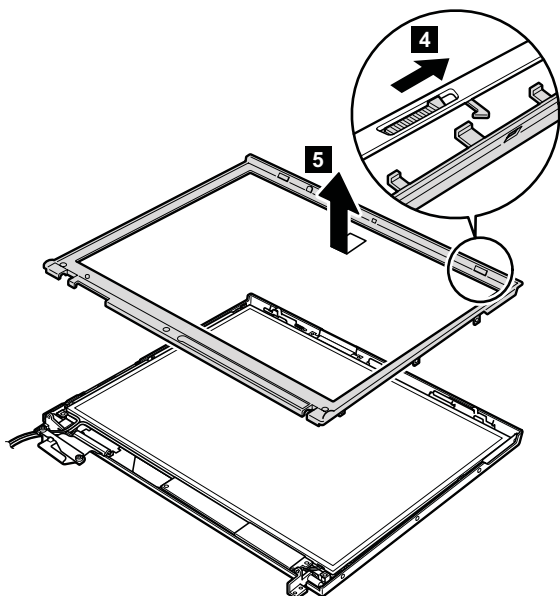

2020 LCD front bezel (15.0-in. LCD models)

For access, remove these FRUs in order:

- “1020 Battery pack (15.0-in. LCD models)” on page 74
- “1040 Hard disk drive” on page 76
- “1060 Keyboard” on page 80
- “1090 **Bluetooth**/Modem daughter card (BMDC-3)” on page 87
- “1110 Keyboard bezel or Keyboard bezel with fingerprint reader (15.0-in. LCD models)” on page 92
- “1120 Mini PCI adapter” on page 98
- “1200 LCD assembly (15.0-in. LCD models)” on page 119

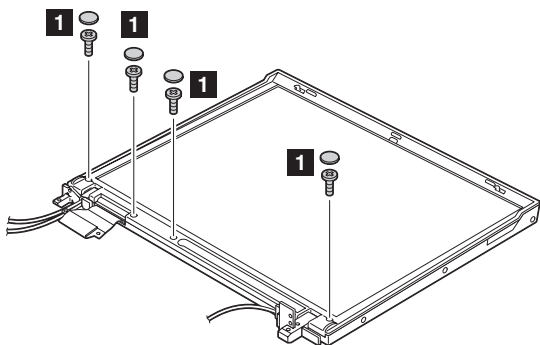

Step	Screw cap	Screw (quantity)	Color	Torque
1		M2 × 4 mm, bind-head, nylon-coated (4)	Black	0.245 Nm (2.5 kgfcm)

(continued)

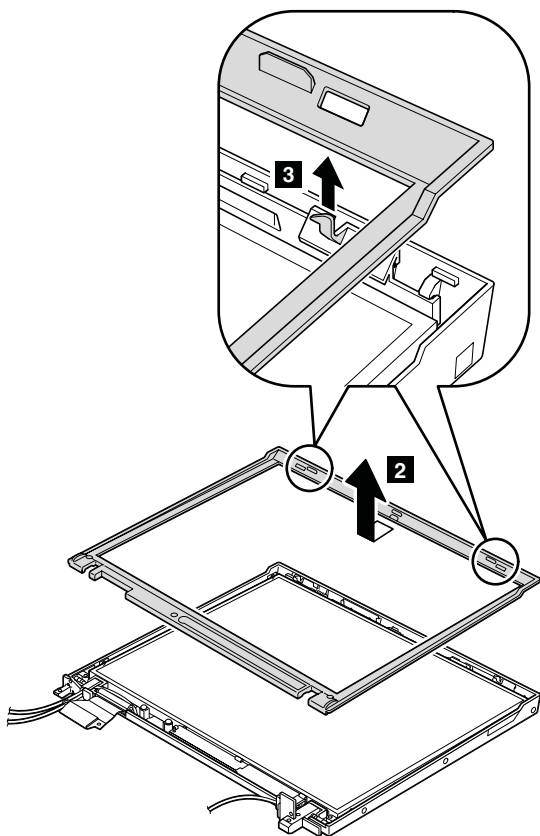

2030 Inverter card (14.1-in. LCD models)

For access, remove these FRUs in order:

- “1010 Battery pack (14.1-in. LCD models)” on page 72
- “1040 Hard disk drive” on page 76
- “1060 Keyboard” on page 80
- “1090 **Bluetooth**/Modem daughter card (BMDC-3)” on page 87
- “1100 Palm rest or Palm rest with fingerprint reader (14.1-in. LCD models)” on page 89
- “1120 Mini PCI adapter” on page 98
- “1160 Keyboard bezel (14.1-in. LCD models)” on page 108
- “1190 LCD assembly (14.1-in. LCD models)” on page 114
- “2010 LCD front bezel (14.1-in. LCD models)” on page 148

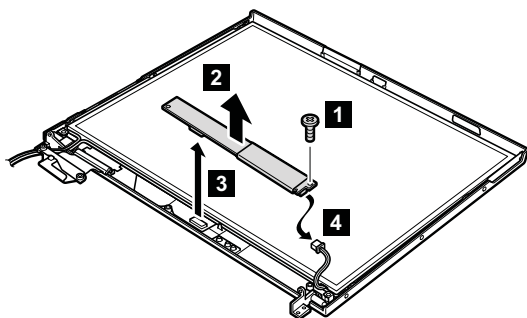

Step	Screw (quantity)	Color	Torque
1	M2 × 3 mm, small-head, nylon-coated (1)	Silver	0.245 Nm (2.5 kgfcm)

When installing: Make sure that connectors **2** and **3** are firmly attached.

Cable routing: When replacing the inverter card, route the connector cable as in this figure:

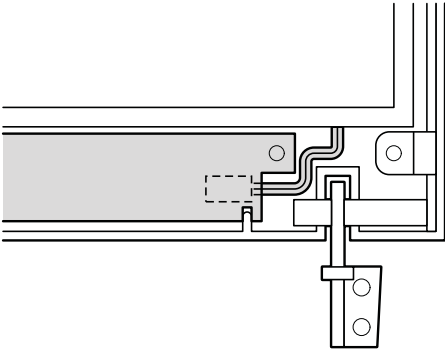

2040 Inverter card (15.0-in. LCD models)

For access, remove these FRUs in order:

- “1020 Battery pack (15.0-in. LCD models)” on page 74
- “1040 Hard disk drive” on page 76
- “1060 Keyboard” on page 80
- “1090 **Bluetooth**/Modem daughter card (BMDC-3)” on page 87
- “1110 Keyboard bezel or Keyboard bezel with fingerprint reader (15.0-in. LCD models)” on page 92
- “1120 Mini PCI adapter” on page 98
- “1200 LCD assembly (15.0-in. LCD models)” on page 119
- “2020 LCD front bezel (15.0-in. LCD models)” on page 150

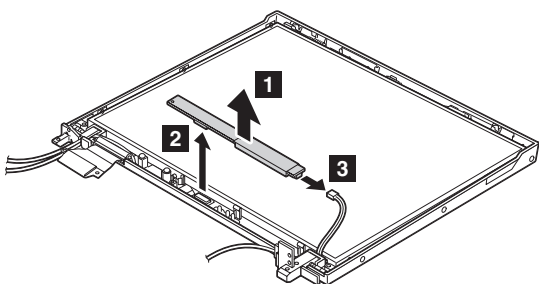

When installing: Make sure that connectors **2** and **3** are firmly attached.

Cable routing: When replacing the inverter card, route the connector cable as in this figure:

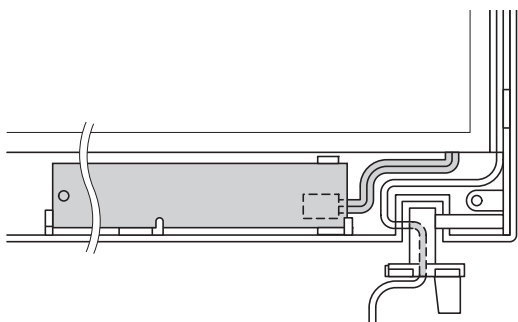

2050 Wireless antenna assemblies, LCD panel, LCD cable assembly, hinges, and LCD cover (14.1-in. LCD models)

For access, remove these FRUs in order:

- “1010 Battery pack (14.1-in. LCD models)” on page 72
- “1040 Hard disk drive” on page 76
- “1060 Keyboard” on page 80
- “1090 **Bluetooth**/Modem daughter card (BMDC-3)” on page 87
- “1100 Palm rest or Palm rest with fingerprint reader (14.1-in. LCD models)” on page 89
- “1120 Mini PCI adapter” on page 98
- “1160 Keyboard bezel (14.1-in. LCD models)” on page 108
- “1190 LCD assembly (14.1-in. LCD models)” on page 114
- “2010 LCD front bezel (14.1-in. LCD models)” on page 148
- “2030 Inverter card (14.1-in. LCD models)” on page 152

Note: Step **1** to **5** are only for the models with the *Bluetooth* wireless features. For the other models, skip step **1** to **5**.

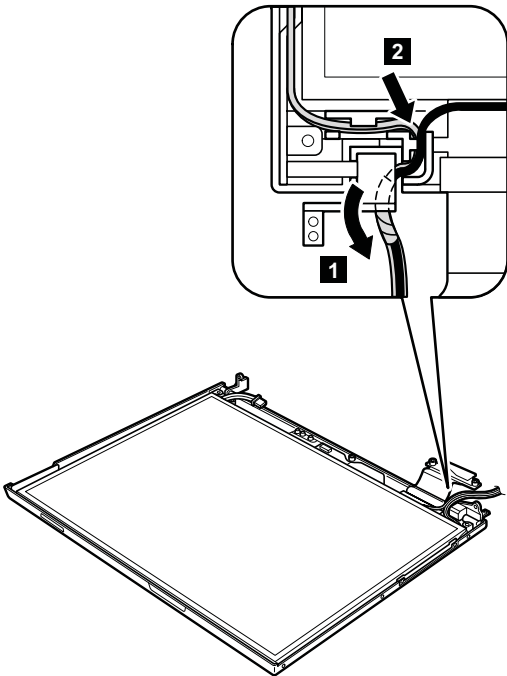

(continued)

Removing and replacing a FRU

Peel the tape securing the *Bluetooth* wireless antenna assembly **3**.

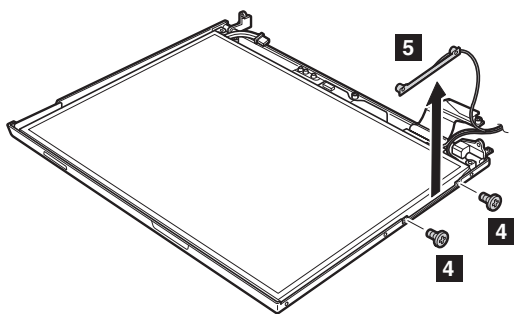
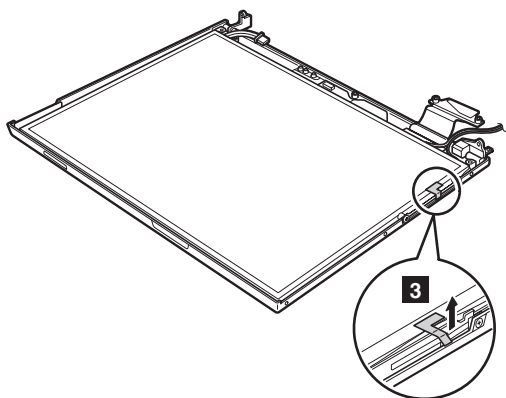

Step	Screw (quantity)	Color	Torque
4	M2 × 2.7 mm, small-head, nylon-coated (2)	Yellow	0.245 Nm (2.5 kgfcm)

(continued)

In step **6** , remove the latch bar as in this figure.

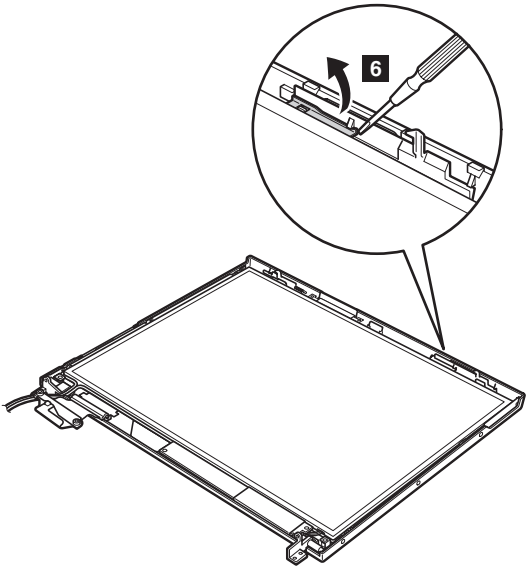

Lift the latch bar in the direction of the arrow **7** , and then remove the left latch in the direction of the arrow **8** .

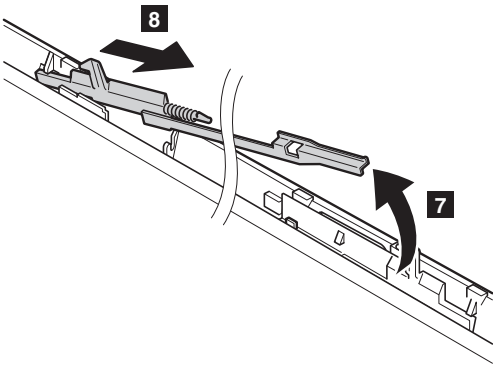

(continued)

Removing and replacing a FRU

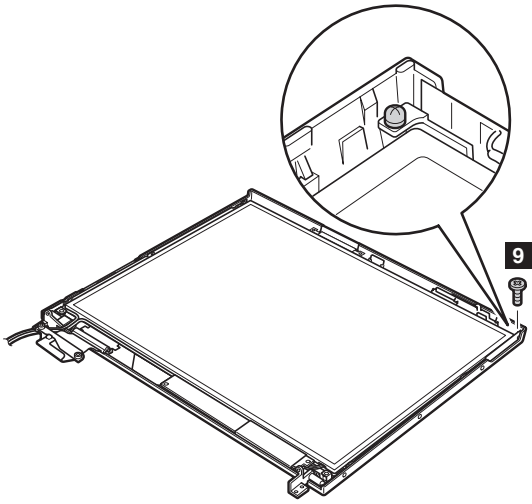

Step	Screw (quantity)	Color	Torque
9	M2 × 3 mm, small-head, nylon-coated (1)	Silver	0.245 Nm (2.5 kgfcm)

(continued)

Slide the spiral tube binding the antenna cables (**10a**), and then release the cables from the cable guide (**10b**). Lift the LCD panel in the direction of arrow **11** , and detach the wireless LAN antenna **12** and the ThinkLight **13** . Then remove the LCD panel in the direction of arrow **14** .

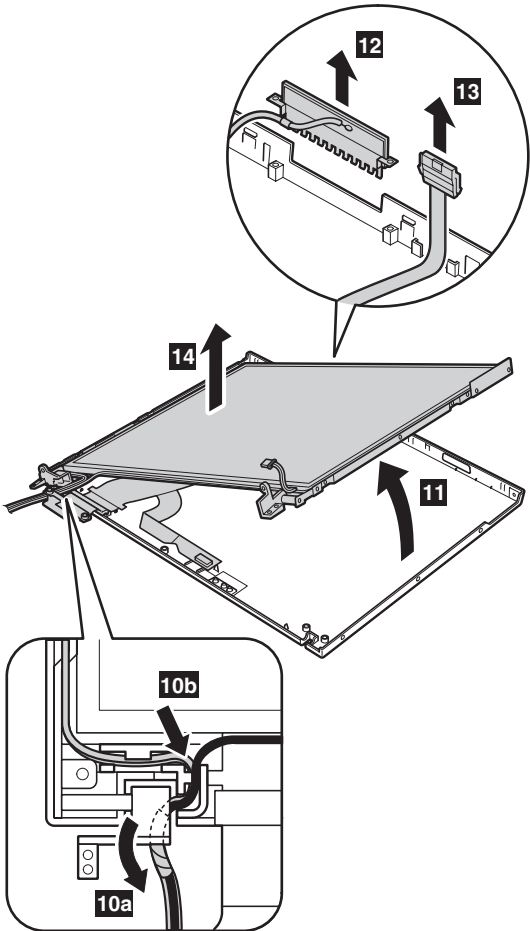

(continued)

Removing and replacing a FRU

Remove the antenna assembly **a** and hinges **b** from the LCD assembly.

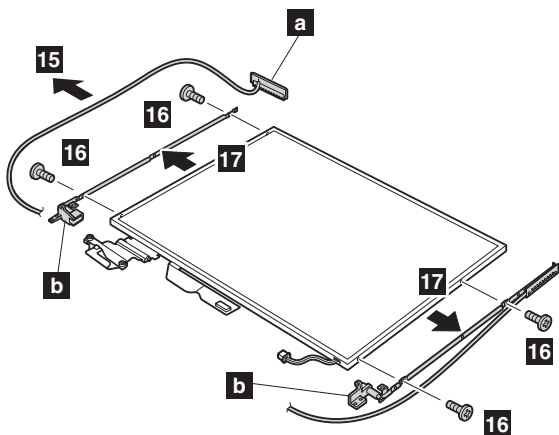

Step	Screw (quantity)	Color	Torque
16	M2 × 3 mm, small-head, nylon-coated (4)	Silver	0.245 Nm (2.5 kgfcm)

Remove two screws **c**, and detach the wireless AUX antenna cable (**c**) from the right hinge.

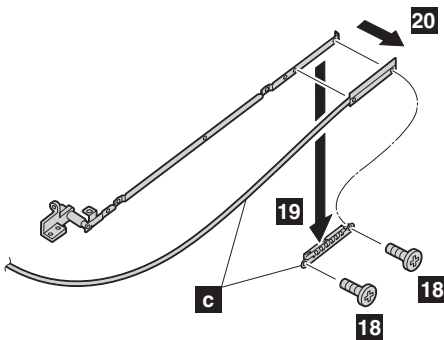

Step	Screw (quantity)	Color	Torque
18	M2 × 3 mm, small-head, nylon-coated (2)	Silver	0.245 Nm (2.5 kgfcm)

(continued)

Turn over the LCD panel and strip off the tape **21** securing the FPC (**c**). Then detach the connector **22** in the direction of the arrow.

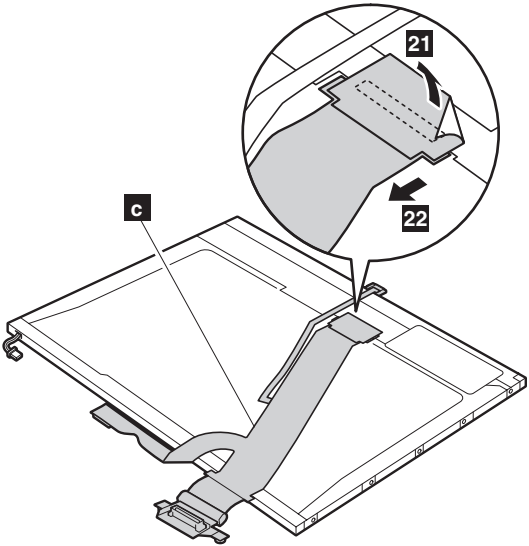

(continued)

Removing and replacing a FRU

Remove the right latch from the LCD cover.

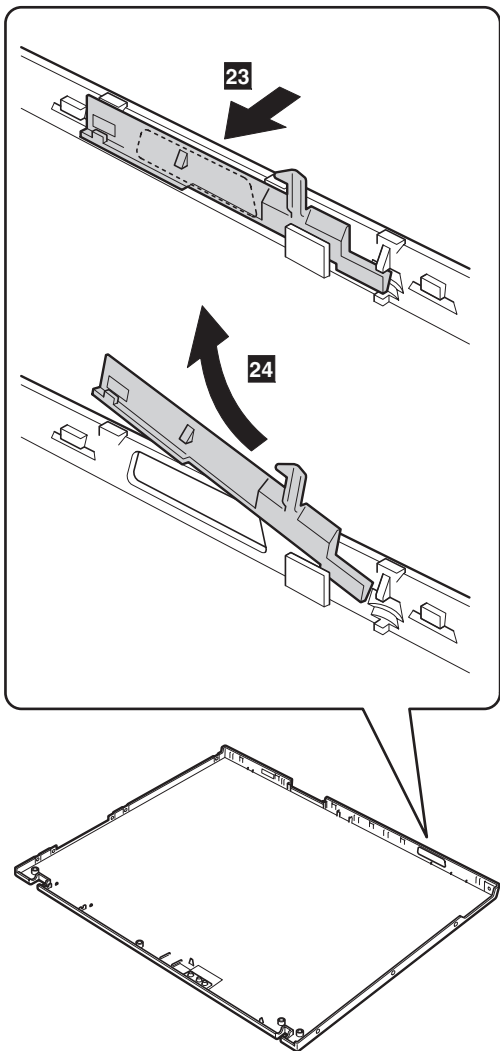

When installing: Follow these steps when you reassemble the LCD unit.

1. Attach the left latch to the LCD cover.

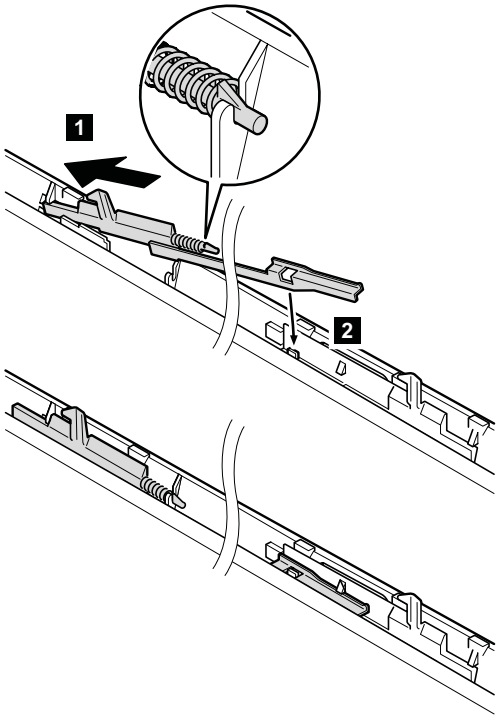

(continued)

Removing and replacing a FRU

2. Paste three gaskets only for the models with *Bluetooth* wireless features. For the other models, skip this step.

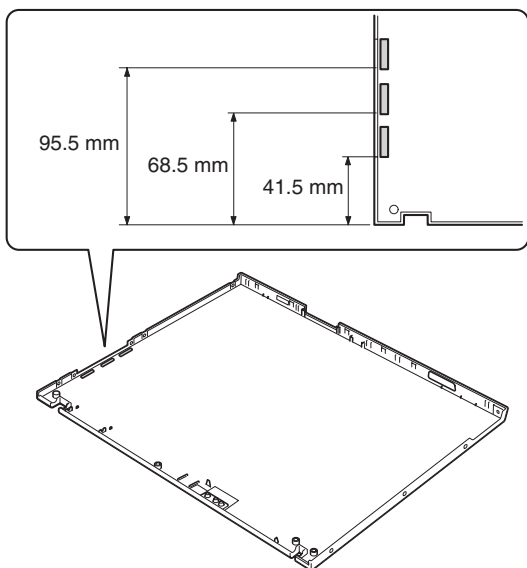

3. Connect the LCD cable assembly to the LCD panel and secure it with the tape.
 4. Attach the wireless LAN antenna cables (MAIN, AUX) and the hinges to the LCD panel.
 5. Attach the LCD panel to the LCD cover.
- (continued)

6. Route the wireless LAN antenna cables as in the following drawings:
 - a.

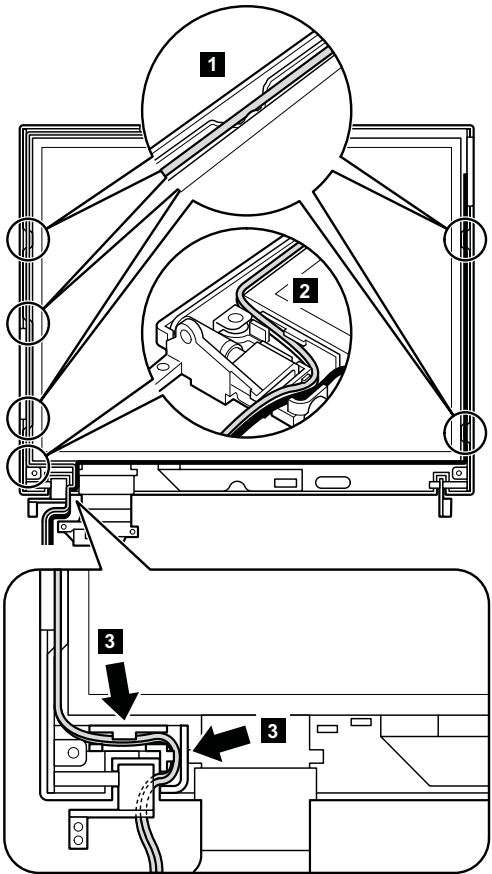

(continued)

Removing and replacing a FRU

b.

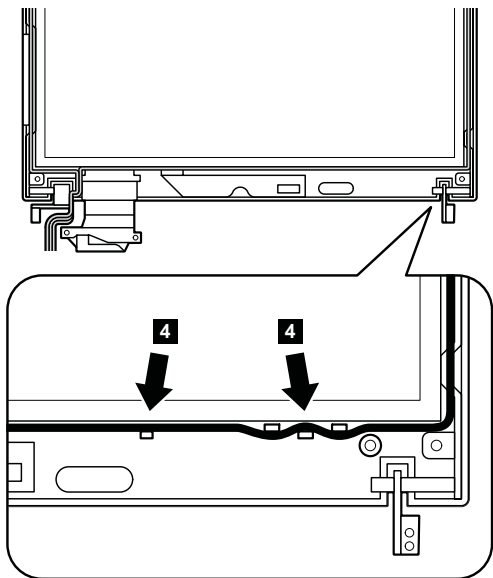

c.

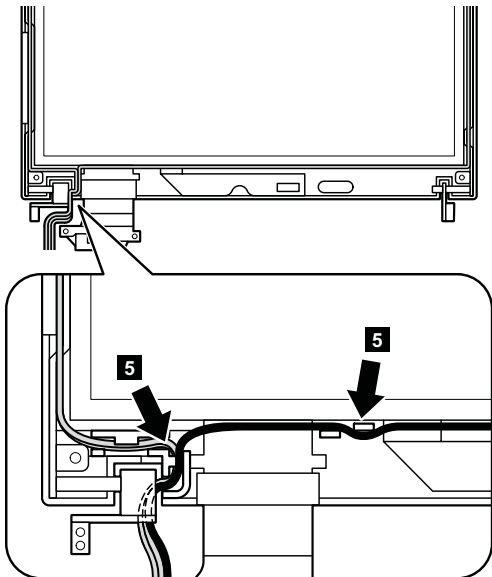

(continued)

- d. Coil the spiral tube round the antenna cables **6** .

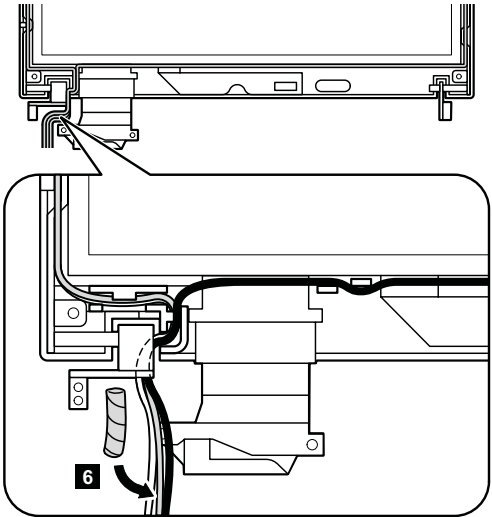

- e. Slide the spiral tube in the direction shown by arrow **7** .

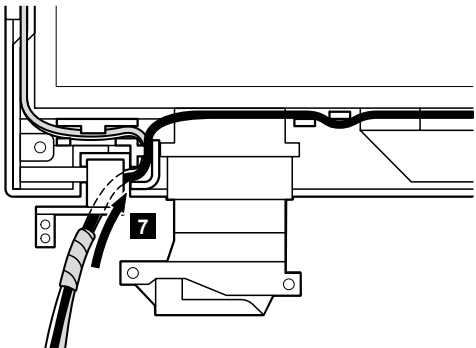

(continued)

Removing and replacing a FRU

Move the spiral tube until it reaches at the cable guide of the LCD cover as in this figure. Make sure that the antenna cable is not pinched by cable clip (**a**).

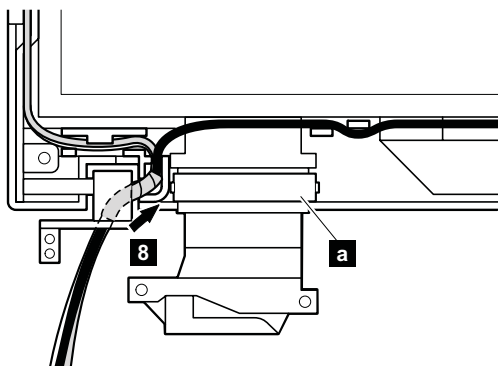

7. Secure the LCD panel with the screws.
8. Attach the right latch to the LCD cover.

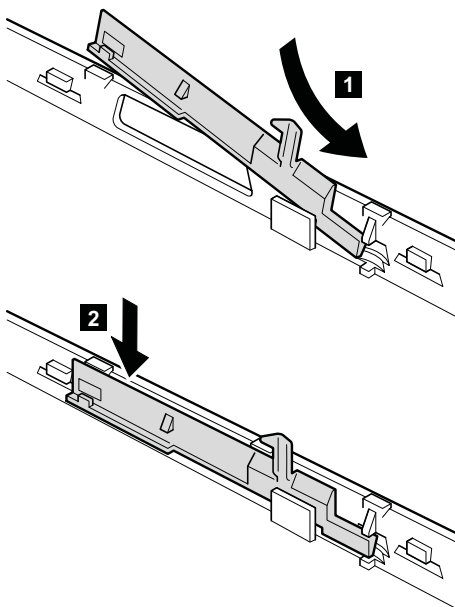

2060 Wireless antenna assemblies, LCD panel, LCD cable assembly, hinges, and LCD cover (15.0-in. LCD models)

For access, remove these FRUs in order:

- “1020 Battery pack (15.0-in. LCD models)” on page 74
- “1040 Hard disk drive” on page 76
- “1060 Keyboard” on page 80
- “1090 **Bluetooth**/Modem daughter card (BMDC-3)” on page 87
- “1110 Keyboard bezel or Keyboard bezel with fingerprint reader (15.0-in. LCD models)” on page 92
- “1120 Mini PCI adapter” on page 98
- “1200 LCD assembly (15.0-in. LCD models)” on page 119
- “2020 LCD front bezel (15.0-in. LCD models)” on page 150
- “2040 Inverter card (15.0-in. LCD models)” on page 154

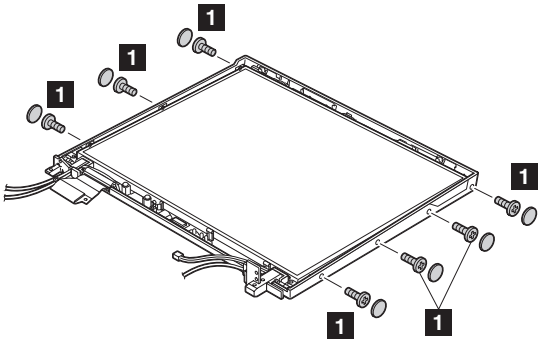

Step	Screw (quantity)	Color	Torque
1	M2 × 4 mm, bind-head, nylon-coated (7)	Black	0.245 Nm (2.5 kgfcm)

(continued)

Removing and replacing a FRU

Release the antenna cables **2**. At the parts indicated by arrows **a**, the antenna cables go through the hinges. When you route the antenna cables, attach the cables firmly.

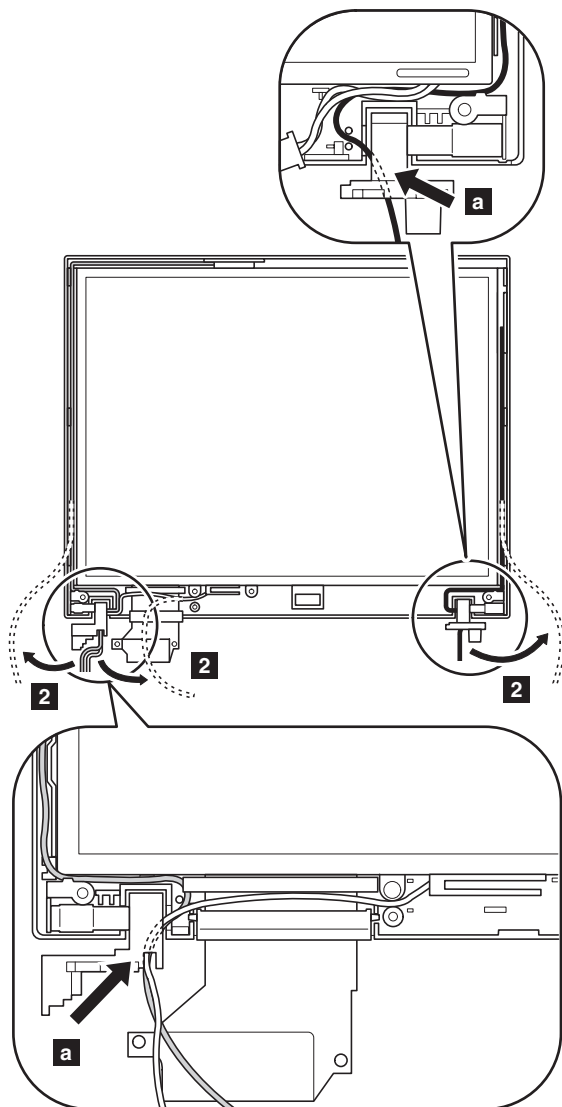

(continued)

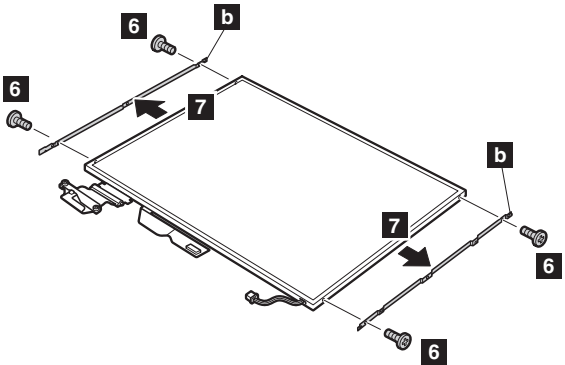
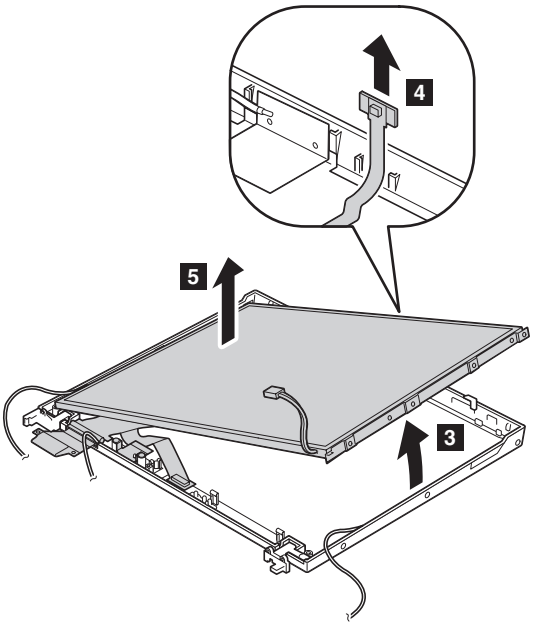

Step	Screw (quantity)	Color	Torque
6	M2 × 3 mm, bind-head, nylon-coated (4)	Silver	0.245 Nm (2.5 kgfcm)

(continued)

Removing and replacing a FRU

Turn over the LCD panel, and detach the connector **8** in the direction of the arrow.

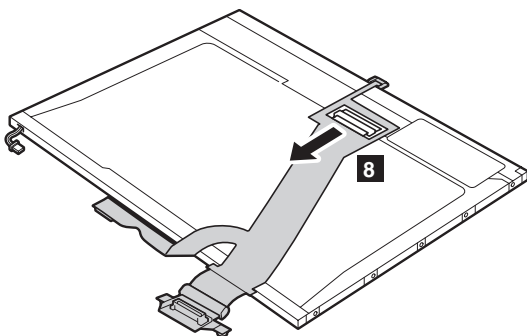

When installing: Make sure that the FPC connector is firmly attached to the LCD panel.

(continued)

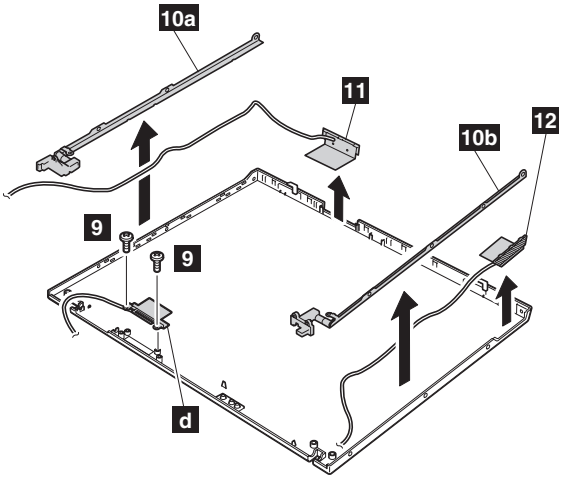

Note: Step **9** is only for the models with the *Bluetooth* wireless features. For the other models, skip this step.

Step	Screw (quantity)	Color	Torque
9	M2 × 4 mm, bind-head, nylon-coated (2)	Black	0.245 Nm (2.5 kgfcm)

Remove the hinges **10a** , **10b** and the wireless LAN antenna cables **11** , **12**

(continued)

Cable routing: When you reassemble the LCD unit, do as follows:

At the left-top corner of the LCD unit, route the antenna cable as in **a**. Do not route the cable over the bracket. To do so, the cable might be pinched between the LCD front bezel and the LCD cover, and the cable or the other parts might be damaged or might not be installed properly.

At the points shown as ○, route the cable as it goes under the projections as in **b**. At the points shown as ▲, push the cable into the ditch between the LCD cover and the bracket by using a screwdriver as in **c**.

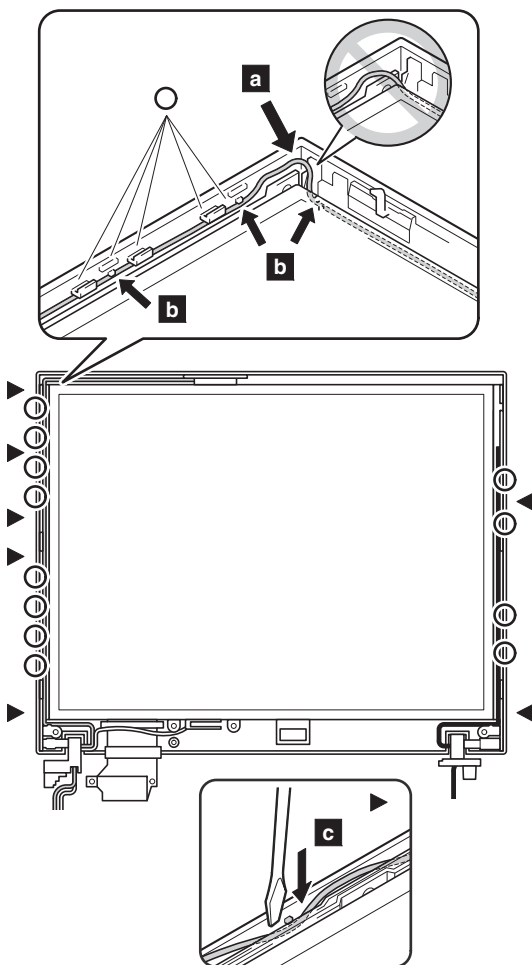

(continued)

Then route the cables to along the cable guides of the LCD cover. When you route the cables around the LCD hinges, do as shown in **c** .

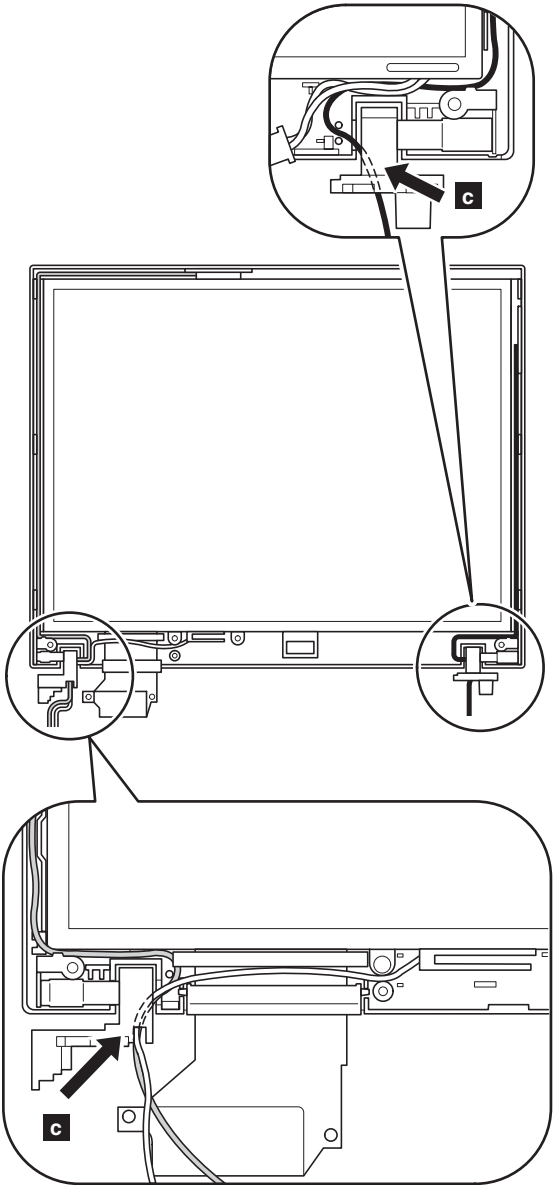

3010 ThinkPad Dock II PCI cover

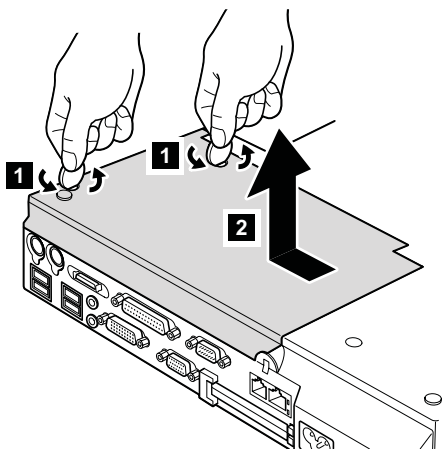

(Bottom view)

3020 ThinkPad Dock II top cover

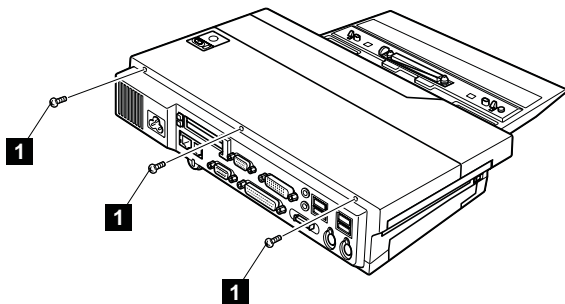

(Rear view)

Step	Screw (quantity)	Torque
1	M2.5 × 4.8 mm (3)	0.392 Nm (4 kgfcm)

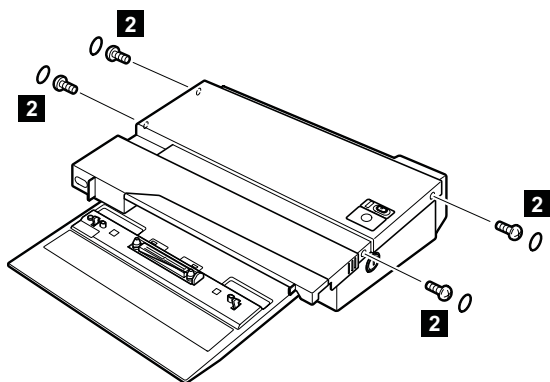

Step	Screw (quantity)	Torque
2	M2.5 × 4.8 mm (4)	0.392 Nm (4 kgfcm)

(continued)

Removing and replacing a FRU

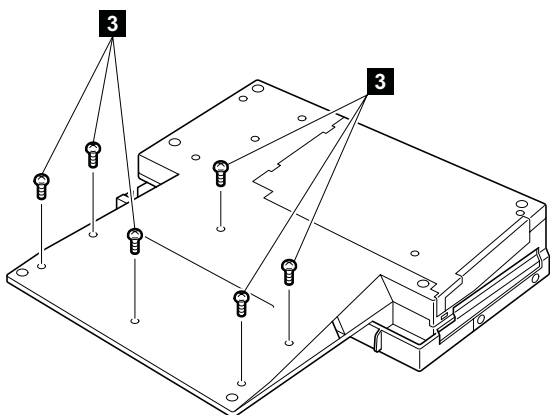

(Bottom view)

Step	Screw (quantity)	Torque
3	M2.5 × 4.8 mm (6)	0.392 Nm (4 kgfcm)

(continued)

Make sure that the system lock key **A** is set to the Unlock position. Release the front latches in step **4**, and then remove the top cover **5**. Then detach the connector cable **6** as in the figure.

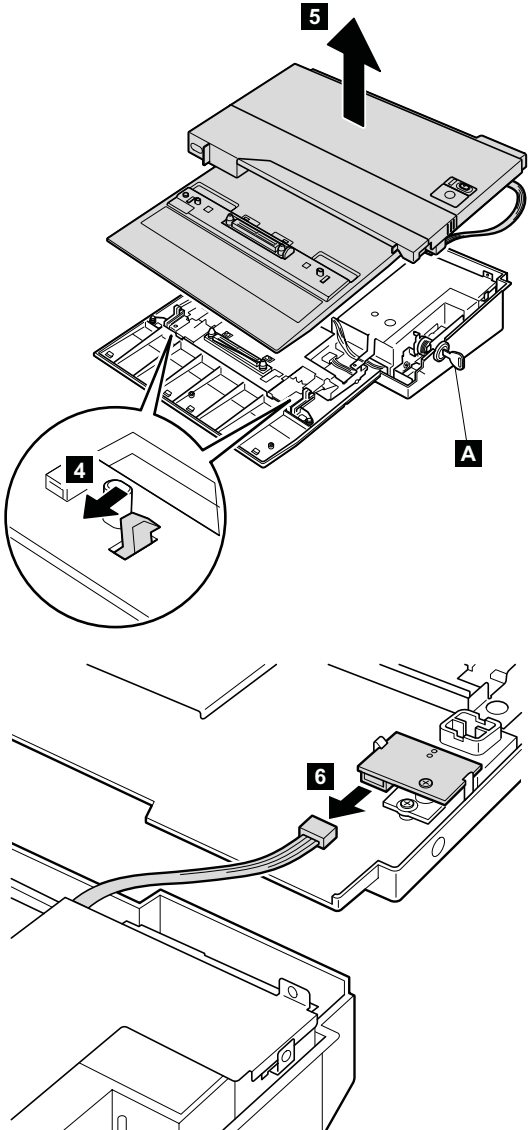

Locations

Front view

- 1** Wireless status indicator
- 2** *Bluetooth* wireless status indicator (for some models)
- 3** System status indicators
- 4** Power status indicators
- 5** External monitor connector
- 6** Ultrabay Slim status indicator
- 7** Ultrabay Slim latch
- 8** Ultrabay Slim device eject lever
- 9** Ultrabay Slim
- 10** TrackPoint pointing stick
- 11** Fingerprint reader (for some models)
- 12** TrackPoint buttons
- 13** Touch pad buttons
- 14** Touch pad
- 15** UltraNav
- 16** Access IBM button
- 17** Volume control buttons
- 18** Power switch
- 19** ThinkLight

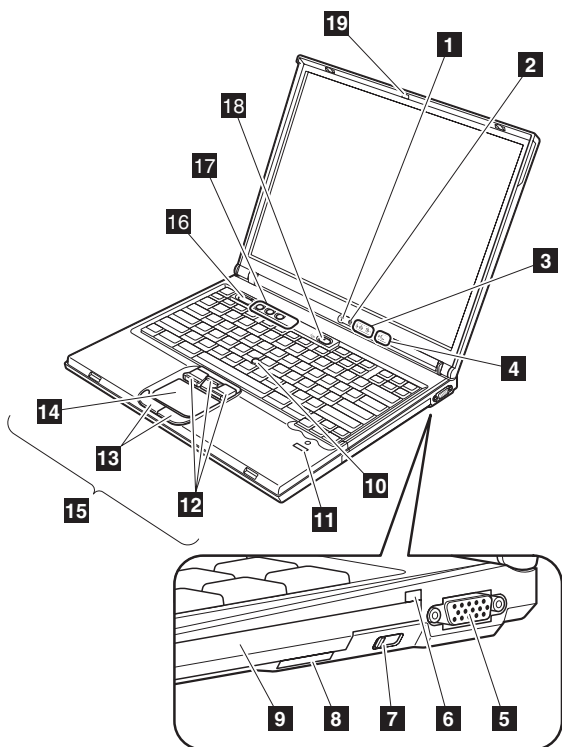

Rear view

- 1** Power status indicators
- 2** *Bluetooth* wireless status indicator (for some models)
- 3** PC Card/ExpressCard eject buttons
- 4** PC Card/ExpressCard slots
- 5** Microphone jack
- 6** Stereo headphone jack
- 7** RJ-45 (Ethernet) connector
- 8** RJ-11 (modem) connector
- 9** TV-out connector
- 10** Universal serial bus (USB) connectors
- 11** Security keyhole
- 12** Parallel connector
- 13** AC power connector

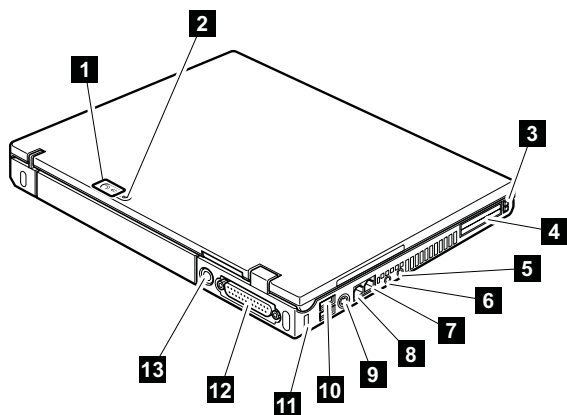

Bottom view

- 1** Hard disk drive
- 2** Optional DIMM slot
- 3** Battery pack
- 4** Battery pack lock (only for 14.1-in LCD models)
- 5** Docking connector
- 6** Battery pack latch
- 7** Infrared port
- 8** Built-in stereo speakers
- 9** LCD latch

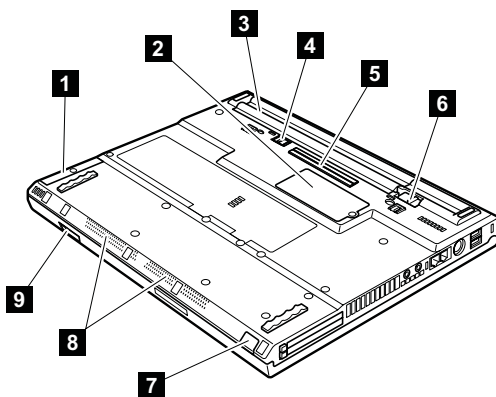

Parts list

- Each FRU is available for all types or models, unless specific types or models are specified.
- A CRU (customer replaceable unit) is identified by a single asterisk (*) or two asterisks (**) in the CRU ID column. An N in the CRU ID column means the part is not a CRU. A single asterisk (*) means the part is a Tier 1 CRU; two asterisks (**) means the part is a Tier 2 CRU.
- FRUs marked with **OP** are available as options.

Overall

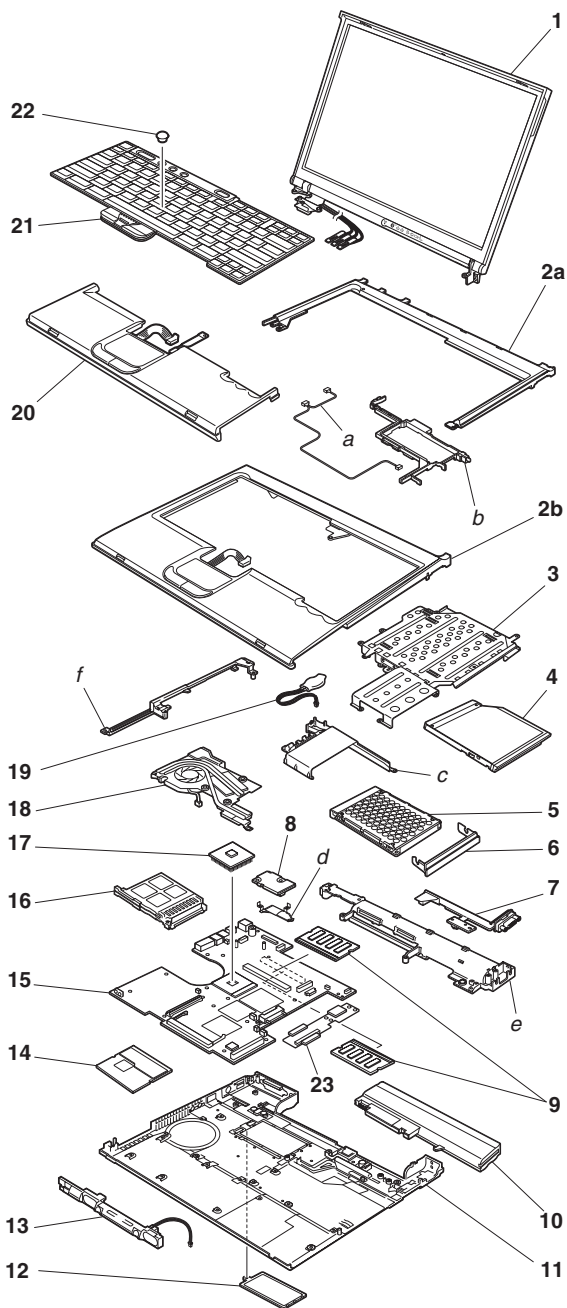

Parts list

No.	FRU	P/N	CRU ID
a-f	See "Miscellaneous parts" on page 205.		
1	LCD unit (see "14.1-in. LCD FRUs" on page 194 and "15.0-in. LCD FRUs" on page 196.)		N
2a	Keyboard bezel assembly (14.1-in.) <ul style="list-style-type: none"> • 1871-CTO, 11x, 12x, 14x, 18x, 19x, 48x, 4Ax, 4Cx, C1x • 1872-CTO, 12x, 4Ax, C1x • 1873-4Ax • 1874-4Ax • 1875-CTO, D1x, D2x, E1x 	91P9540	N
2b	Keyboard bezel assembly with touch pad (15.0-in.) <ul style="list-style-type: none"> • 1871-CTO, 22x, 23x, 26x, 27x • 1875-CTO, D3x, D9x, EAx, ECx • 1876-CTO, DBx, EEx 	91P8735	N
	Keyboard bezel assembly with fingerprint reader (15.0-in.) <ul style="list-style-type: none"> • 1871-CTO, 24x, 25x, 86x, F4x • 1875-CTO, DAx, DCx, DMx, EBx, EDx, F4x • 1876-CTO, EFx 	26R8411	N
		91P8685	N
3	Ultrabay guide rail assembly (14.1-in.) <ul style="list-style-type: none"> • 1871-CTO, 11x, 12x, 14x, 18x, 19x, 48x, 4Ax, 4Cx, C1x • 1872-CTO, 12x, 4Ax, C1x • 1875-CTO, D1x, D2x, E1x 	91P8394	N
	Ultrabay guide rail assembly (14.1-in., fingerprint reader) <ul style="list-style-type: none"> • 1871-CTO, 13x, 15x, 16x, 17x, 1Gx, 1Hx, 4Bx, F1x • 1873-4Ax • 1874-4Ax • 1875-CTO, D6x, DKx, DLx, E5x, F1x 	91P8682	N
	Ultrabay guide rail assembly (15.0-in.) <ul style="list-style-type: none"> • 1871-CTO, 22x, 23x, 26x, 27x • 1875-CTO, D3x, D9x, EAx, ECx • 1876-CTO, DBx, EEx 	13R2920	N
	Ultrabay guide rail assembly (15.0-in., fingerprint reader) <ul style="list-style-type: none"> • 1871-CTO, 24x, 25x, 86x, F4x • 1875-CTO, DAx, DCx, DMx, EBx, EDx, F4x • 1876-CTO, EFx 	91P8683	N

(continued)

No.	FRU	P/N	CRU ID	
4	DVD drive 8x OP <ul style="list-style-type: none"> • 1871-CTO, 11x, 18x, 48x • 1875-CTO, D1x, D3x 			
	HLDS	92P6579	*	
	TEAC	92P5991	*	
	DVD/CD-RW combo drive OP <ul style="list-style-type: none"> • 1871-CTO, 12x, 13x, 15x, 16x, 19x, 1Gx, 22x, 23x, 24x, 25x, 27x, 4Ax, 4Bx, 4Cx, 86x, C1x, F1x, F4x • 1872-CTO, 12x, 4Ax, C1x • 1873-4Ax • 1874-4Ax • 1875-CTO, D2x, D6x, D9x, DAx, DCx, DKx, DLx, DMx, F1x, F4x • 1876-CTO, DBx 			
	PCC	39T2505	*	
	HLDS	13N6769	*	
	DVD-RAM/RW drive (PCC) OP <ul style="list-style-type: none"> • 1871-CTO, 14x, 17x, 1Hx 	39T2507	*	
	Travel cover <ul style="list-style-type: none"> • 1875-CTO, xxE, xxJ, xxU • 1876-CTO, xxE, xxJ, xxU 	13N5108	*	
	For optional Ultrabay devices, see "Optional FRUs" on page 209.			
	5	Hard disk drive, 30 GB, 9.5 mm, 4,200 rpm <ul style="list-style-type: none"> • Supported by CTO 		
		Fujitsu	13N6903	*
		HGST	13N6883	*
Hard disk drive, 40 GB, 9.5 mm, 4,200 rpm <ul style="list-style-type: none"> • Supported by CTO 				
Fujitsu		13N6885	*	
HGST		13N6905	*	
Hard disk drive, 40 GB, 9.5 mm, 5,400 rpm <ul style="list-style-type: none"> • 1871-CTO, 11x, 12x, 13x, 14x, 15x, 16x, 17x, 18x, 1Gx, 1Hx, 22x, 23x, 24x, 48x, 4Ax, 4Bx, 4Cx, 86x, C1x, F1x, F4x • 1872-CTO, 12x, 4Ax, C1x • 1873-4Ax • 1874-4Ax • 1875-CTO, D1x, D2x, D3x, D6x, D9x, DAx, DCx, DKx, F1x, F4x • 1876-CTO, DBx 				
Fujitsu		13N6913	*	
HGST		39T2521	*	
Toshiba		13N6919	*	

(continued)

Parts list

No.	FRU	P/N	CRU ID
5	Hard disk drive, 60 GB, 9.5 mm, 5,400 rpm • 1871-CTO, 19x • 1875-CTO, DLx, DMx		
	Fujitsu	13N6915	*
	HGST	39T2523	*
	Hard disk drive, 60 GB, 9.5 mm, 7,200 rpm, HGST • Supported by CTO	13N6897	*
	Hard disk drive, 80 GB, 9.5 mm, 5,400 rpm • 1871-CTO, 25x, 26x, 27x		
	Fujitsu HGST	13N6917 39T2525	* *
6	Cover, Hard disk drive (14.1-in.) • 1871-CTO, 1xx, 4xx, C1x, F1x • 1872-CTO, 1xx, 4xx, C1x • 1873-4Ax • 1874-4Ax • 1875-CTO, D1x, D2x, D6x, DKx, DLx, E1x, E5x, F1x	13N5530	*
	Cover, Hard disk drive (15.0-in.) • 1871-CTO, 2xx, 8xx, F4x • 1875-CTO, D3x, D9x, DAx, DCx, DMx, EAx, EBx, ECx, EDx, F4x • 1876-CTO, DBx, EEx EFx	13R2922	*
7	VGA and Ultrabay eject button cable (14.1-in.) • 1871-CTO, 1xx, 4xx, C1x, F1x • 1872-CTO, 1xx, 4xx, C1x • 1873-4Ax • 1874-4Ax • 1875-CTO, D1x, D2x, D6x, DKx, DLx, E1x, E5x, F1x	91P6894	N
	VGA and Ultrabay eject button cable (15.0-in.) • 1871-CTO, 2xx, 8xx, F4x • 1875-CTO, D3x, D9x, DAx, DCx, DMx, EAx, EBx, ECx, EDx, F4x • 1876-CTO, DBx, EEx EFx	91P6895	N

(continued)

No.	FRU	P/N	CRU ID
8	ThinkPad Integrated 56K Modem (MDC-2) <ul style="list-style-type: none"> • 1871-CTO, 11x, 12x, 13x, 15x, 16x, 17x, 18x, 19x, 1Gx, 1Hx, 22x, 23x, 24x, 26x, 27x, 48x, 4Ax, 86x, C1x • 1872-CTO, 12x, 4Ax, C1x • 1873-4Ax • 1874-4Ax • 1875-CTO, D1x, D2x, D3x, D6x, D9x, DAx, DCx, DKx, DLx, DMx, E1x, E5x, EAx, EBx, ECx, EDx • 1876-CTO, DBx, EEx, EFx 	93P4212	**
	IBM Integrated <i>Bluetooth</i> IV with 56K Modem (BMDC-3) <ul style="list-style-type: none"> • 1871-CTO, 14x, 25x, 4Bx, 4Cx, Fxx • 1875-CTO, Fxx 	39T0022	**
9	256-MB DDR2-533 SDRAM SO-DIMM (PC2-4200) card OP <ul style="list-style-type: none"> • 1871-CTO, 11x, 12x, 13x, 16x, 22x, 24x • 1872-CTO, 12x 	73P3841	*
	512-MB DDR2-533 SDRAM SO-DIMM (PC2-4200) card OP <ul style="list-style-type: none"> • 1871-CTO, 14x, 15x, 17x, 18x, 19x, 1Gx, 1Hx, 23x, 25x, 26x, 27x, 48x, 4Ax, 4Bx, 4Cx, 8xx, Cxx, Fxx • 1872-CTO, 4Ax, Cxx • 1873-4Ax • 1874-4Ax • 1875-CTO, DKx, DLx, DMx, Fxx 	73P3843	*
	1-GB DDR2-533 SDRAM SO-DIMM (PC2-4200) card OP <ul style="list-style-type: none"> • 1875-CTO, D1x, D2x, D3x, D6x, D9x, DAx, DCx • 1876-CTO, DBx 	73P3845	*
	2-GB DDR2-533 SDRAM SO-DIMM (PC2-4200) card OP <ul style="list-style-type: none"> • Supported by CTO 	73P3847	*

(continued)

Parts list

No.	FRU	P/N	CRU ID	
10	Battery pack, Li-ion (6 cell) 4.8 Ah OP <ul style="list-style-type: none"> • 1871-CTO, 1xx, 2xx, 4xx, 8xx, Cxx, Fxx • 1872-CTO, 1xx, Cxx • 1873-4Ax • 1874-4Ax • 1875-CTO, Dxx, Fxx • 1876-CTO, Dxx 			
	Sanyo	92P1087	*	
	Sony	92P1089	*	
	Panasonic	92P1091	*	
	Battery pack, Li-ion (9 cell) 7.2 Ah OP <ul style="list-style-type: none"> • Supported by CTO 			
	Sanyo	92P1077	*	
	Sony	92P1073	*	
	Panasonic	92P1069	*	
	Dummy battery pack <ul style="list-style-type: none"> • Supported by CTO 	91P9719	*	
	For optional battery packs, see "Optional FRUs" on page 209.			
	11	Base cover assembly 1871 (14.1-in.) <ul style="list-style-type: none"> • 1871-CTO, 1xx, 4xx, C1x, F1x 	26R8971	N
		Base cover assembly 1871 (15.0-in.) <ul style="list-style-type: none"> • 1871-CTO, 2xx, 8xx, F4x 	26R8975	N
Base cover assembly 1872 (14.1-in.) <ul style="list-style-type: none"> • 1872-CTO, 1xx, 4xx, C1x 		26R8972	N	
Base cover assembly 1872 (15.0-in.) <ul style="list-style-type: none"> • 1872-CTO 		26R8976	N	
Base cover assembly 1873 (14.1-in.) <ul style="list-style-type: none"> • 1873-4Ax 		26R9190	N	
Base cover assembly 1874 (14.1-in.) <ul style="list-style-type: none"> • 1874-4Ax 		26R9191	N	
Base cover assembly 1875 (14.1-in.) <ul style="list-style-type: none"> • 1875-CTO, D1x, D2x, D6x, DKx, DLx, E1x, E5x, F1x 		26R8973	N	
Base cover assembly 1875 (15.0-in.) <ul style="list-style-type: none"> • 1875-CTO, D3x, D9x, DAx, DCx, DMx, EAx, EBx, ECx, EDx, F4x 		26R8977	N	
Base cover assembly 1876 (15.0-in.) <ul style="list-style-type: none"> • 1876-CTO, DBx, EEx, EFx 		26R8974	N	

(continued)

No.	FRU	P/N	CRU ID
12	Cover, DIMM slot	13N5667	*
13	Speaker (14.1-in.) <ul style="list-style-type: none"> • 1871-CTO, 1xx, 4xx, C1x, F1x • 1872-CTO, 1xx, 4xx, C1x • 1873-4Ax • 1874-4Ax • 1875-CTO, D1x, D2x, D6x, DKx, DLx, E1x, E5x, F1x 	39T0797	N
	Speaker (15.0-in.) <ul style="list-style-type: none"> • 1871-CTO, 2xx, 8xx, F4x • 1875-CTO, D3x, D9x, DAx, DCx, DMx, EAx, EBx, ECx, EDx, F4x • 1876-CTO, DBx, EEx, EFx 	39T0800	N
14	Intel PRO Wireless 2200BG Mini-PCI Adapter		
	US <ul style="list-style-type: none"> • 1871-CTO, 1xU, 22U, 24U, 4AU • 1872-CTO, 1xU, 4AU • 1873-4Ax for xxF, xxU, xxV • 1874-4Ax for xxF, xxU, xxV • 1875-CTO, DKU, DLU, DMU 	93P3483	** (*1)
	ROW <ul style="list-style-type: none"> • 1871-CTO, 1xx except 1xU, 23x, 25x, 26x, 27x, 4Ax except 4AU • 1872-CTO, 1xx except 1xU, 4Ax except 4AU • 1873-4Ax for xxA, xxB, xxG, xxL, xxM, xxP, xxQ, xxS, xxY • 1874-4Ax for xxA, xxB, xxG, xxL, xxM, xxP, xxQ, xxS, xxY • 1875-CTO, D1U, D3U, DKF, DLF, DMF 	93P3485	** (*1)
*1: These Mini PCI Adapters are only CRUs in the 14.1-in. LCD models. They are not CRUs in the 15.0-in. LCD models.			

(continued)

Parts list

No.	FRU	P/N	CRU ID
14	Intel PRO Wireless 2915ABG Mini-PCI Adapter		
	US • 1871-CTO, 48U, 4BU, 4CU, 86U, C1U • 1872-CTO, C1U • 1875-CTO, D2U, D6U, D9U, DAU, DCU • 1876-CTO, DBU	93P4235	** (*1)
	EU • 1871-CTO, 25x, FxG • 1875-CTO, FxG	93P4237	** (*1)
	HB • 1871-CTO, 25x, FxG • 1875-CTO, FxG	93P4241	** (*1)
	JP • 1871-CTO, xxE, xxJ • 1875-CTO, xxE, xxJ	93P4239	** (*1)
*1: These Mini PCI Adapters are only CRUs in the 14.1-in. LCD models. They are not CRUs in the 15.0-in. LCD models.			
15	System board assembly, Intel 915GM, Gigabit Ethernet with security chip/fingerprint reader • 1871-CTO, 11x, 12x, 13x, 14x, 15x, 16x, 17x, 18x, 19x, 1Gx, 1Hx, 22x, 23x, 24x, 25x, 26x, 27x, 48x, 4Ax, 4Bx, 4Cx, 86x, C1x • 1872-CTO, 12x, 4Ax, C1x • 1873-4Ax • 1874-4Ax • 1875-CTO, D1x, D2x, D3x, D6x, D9x, DAx, DCx, DKx, DLx, DMx, E1x, E5x, EAx, EBx, ECx, EDx, F1x • 1876-CTO, DBx, EEx, EFx	39T0324	N
16	PC Card/ExpressCard slots	91P8833	N
17	CPU assembly, Intel Pentium M processor 730 (1.6 GHz) • 1871-CTO, 1xx, 22x, 23x, 24x, 27x • 1872-CTO, 1xx • 1875-CTO, D3x, DKx, E1x, E5x, EAx, EBx	39T0045	N
	CPU assembly, Intel Pentium M processor 740 (1.73 GHz) • 1875-CTO, D1x, D2x, D6x, D9x, DAx, DCx, DLx, DMx • 1876-CTO, DBx	39T0046	N

(continued)

No.	FRU	P/N	CRU ID
17	CPU assembly, Intel Pentium M processor 750 (1.86 GHz) <ul style="list-style-type: none"> • 1871-CTO, 25x, 26x, 4xx, 8xx, C1x, Fxx • 1872-CTO, C1x • 1873-4Ax • 1874-4Ax • 1875-CTO, ECx, EDx, Fxx • 1876-CTO, EEx, EFx 	39T0047	N
	CPU assembly, Intel Pentium M processor 760 (2.0 GHz) <ul style="list-style-type: none"> • Supported by CTO 	39T0048	N
	CPU assembly, Intel Pentium M processor 770 (2.13 GHz) <ul style="list-style-type: none"> • Supported by CTO 	39T0049	N
18	Fan assembly	26R8197	N
19	Backup battery	02K6572	**
	Note: This FRU is only a CRU in the 14.1-in. LCD models. It is not a CRU in the 15.0-in. LCD models.		
20	Palm rest assembly with touch pad (14.1-in.) <ul style="list-style-type: none"> • 1871-CTO, 22x, 23x, 26x, 27x • 1873-4Ax • 1874-4Ax • 1875-CTO, D3x, D9x, EAx, ECx • 1876-CTO, DBx, EEx 	91P8734	**
	Palm rest assembly without touch pad (14.1-in.) <ul style="list-style-type: none"> • Supported by CTO 	91P8399	**
	Palm rest assembly with touch pad, fingerprint reader (14.1-in.) <ul style="list-style-type: none"> • 1871-CTO, 24x, 25x, 86x, F4x • 1875-CTO, DAx, DCx, DMx, EBx, EDx, F4x • 1876-CTO, EFx 	26R8410 91P8684	**
21	Keyboard (see “Keyboard” on page 199.)		**
22	Track point stick caps	91P9642	*
23	Interposer card <ul style="list-style-type: none"> • 1871-CTO, 2xx, 8xx, F4x • 1875-CTO, D3x, D9x, DAx, DCx, DMx, EAx, EBx, ECx, EDx, F4x • 1876-CTO, DBx, EEx, EFx 	39T0030	N
—	Telephone cable (SAN TAI)	91P6839	*
—	Thermal grease	46L4855	N

14.1-in. LCD FRUs

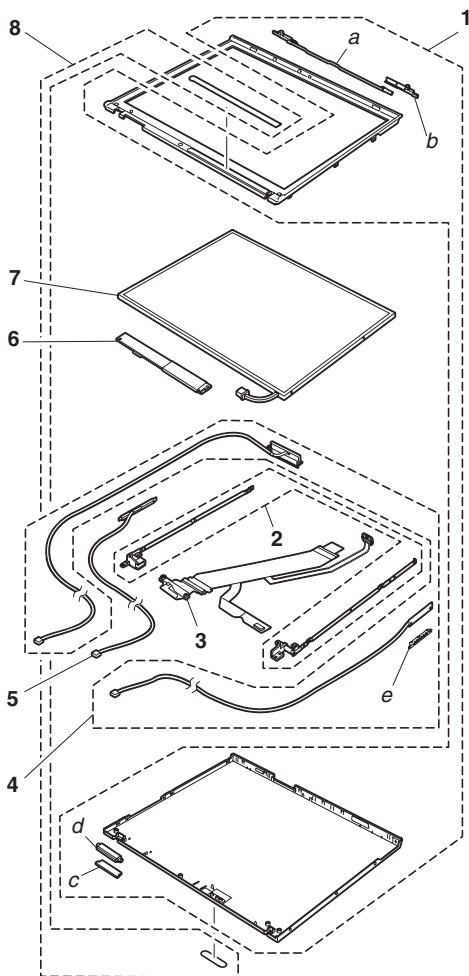

14.1-in. XGA TFT

No.	FRU	P/N	CRU ID
<i>a-d</i>	See "Miscellaneous parts" on page 205.		
1	LCD cover kit (WW) <ul style="list-style-type: none"> • 1871-CTO, 1xx, 4xx, C1x, F1x • 1872-CTO, 1xx, 4xx, C1x • 1873-4Ax • 1874-4Ax • 1875-CTO, D1x, D2x, D6x, DKx, DLx, E1x, E5x, F1x 	13R2569	N
2	Hinges, 14.1-in. <ul style="list-style-type: none"> • 1871-CTO, 1xx, 4xx, C1x, F1x • 1872-CTO, 1xx, 4xx, C1x • 1873-4Ax • 1874-4Ax • 1875-CTO, D1x, D2x, D6x, DKx, DLx, E1x, E5x, F1x 	91P8388	N
3	LCD cable assembly, 14.1-in. XGA <ul style="list-style-type: none"> • 1871-CTO, 1xx, 4xx, C1x, F1x • 1872-CTO, 1xx, 4xx, C1x • 1873-4Ax • 1874-4Ax • 1875-CTO, D1x, D2x, D6x, DKx, DLx, E1x, E5x, F1x 	91P6889	N
4	Wireless antenna assembly, 14.1-in. <ul style="list-style-type: none"> • 1871-CTO, 1xx, 4xx, C1x, F1x • 1872-CTO, 1xx, 4xx, C1x • 1873-4Ax • 1874-4Ax • 1875-CTO, D1x, D2x, D6x, DKx, DLx, E1x, E5x, F1x 	91P6896	N
5	<i>Bluetooth</i> wireless antenna assembly, 14.1-in. <ul style="list-style-type: none"> • 1871-CTO, 14x, 4Bx, 4Cx, F1x • 1875-CTO, F1x 	91P6897	N
6	Inverter card, 14.1-in. <ul style="list-style-type: none"> • 1871-CTO, 1xx, 4xx, C1x, F1x • 1872-CTO, 1xx, 4xx, C1x • 1873-4Ax • 1874-4Ax • 1875-CTO, D1x, D2x, D6x, DKx, DLx, E1x, E5x, F1x 	27K9972	N
7	LCD panel, 14.1-in. XGA <ul style="list-style-type: none"> • 1871-CTO, 1xx, 4xx, C1x, F1x • 1872-CTO, 1xx, 4xx, C1x • 1873-4Ax • 1874-4Ax • 1875-CTO, D1x, D2x, D6x, DKx, DLx, E1x, E5x, F1x 		
	HYDIS	92P6733	N
	LG	92P6726	N
	Samsung	92P6759	N
8	Clear plate	26R8409	N

15.0-in. LCD FRUs

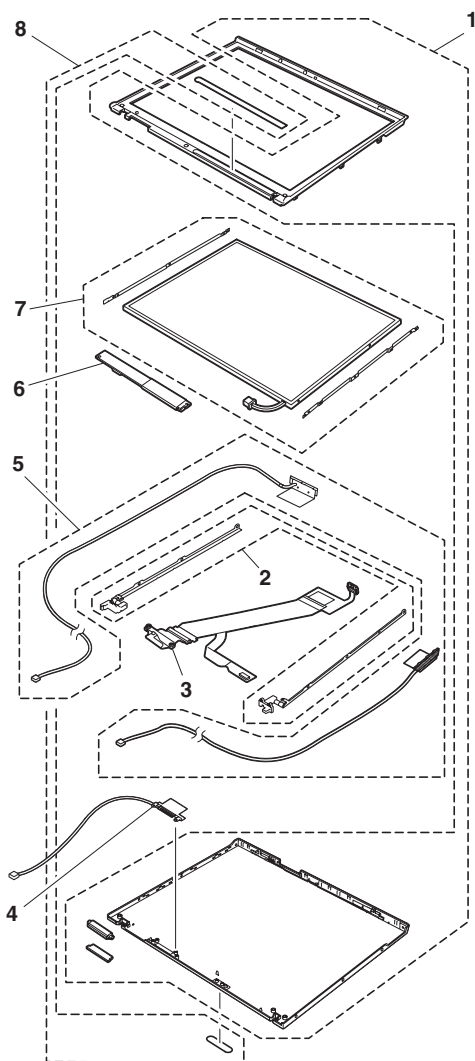

15.0-in. XGA TFT

No.	FRU	P/N	CRU ID
1	LCD cover kit, 15.0-in. (WW) <ul style="list-style-type: none"> • 1871-CTO, 22x, 23x, 24x, 25x, 26x, 27x, 86x • 1875-CTO, F4x, D3x, D9x, DAx, DCx, DMx, EAx, EBx, ECx, EDx • 1876-CTO, DBx, EEx, EFx 	13R2917	N
2	Hinges, 15.0-in. <ul style="list-style-type: none"> • 1871-CTO, 22x, 23x, 24x, 25x, 26x, 27x, 86x • 1875-CTO, F4x, D3x, D9x, DAx, DCx, DMx, EAx, EBx, ECx, EDx • 1876-CTO, DBx, EEx, EFx 	13R2918	N
3	LCD cable assembly, 15.0-in. XGA <ul style="list-style-type: none"> • 1871-CTO, 22x, 23x, 24x, 25x, 26x, 27x, 86x • 1875-CTO, F4x, D3x, D9x, DAx, DCx, DMx, EAx, EBx, ECx, EDx • 1876-CTO, DBx, EEx, EFx 	91P6891	N
4	<i>Bluetooth</i> wireless antenna, 15.0-in. <ul style="list-style-type: none"> • 1871-CTO, 22x, 23x, 24x, 25x, 26x, 27x, 86x • 1875-CTO, F4x, D3x, D9x, DAx, DCx, DMx, EAx, EBx, ECx, EDx • 1876-CTO, DBx, EEx, EFx 	91P6860	N
5	Antenna, 15.0-in. <ul style="list-style-type: none"> • 1871-CTO, 22x, 23x, 24x, 25x, 26x, 27x, 86x • 1875-CTO, F4x, D3x, D9x, DAx, DCx, DMx, EAx, EBx, ECx, EDx • 1876-CTO, DBx, EEx, EFx 	91P6859	N
6	Inverter card, 15.0-in. XGA <ul style="list-style-type: none"> • 1871-CTO, 22x, 23x, 24x, 25x, 26x, 27x, 86x • 1875-CTO, F4x, D3x, D9x, DAx, DCx, DMx, EAx, EBx, ECx, EDx • 1876-CTO, DBx, EEx, EFx 	27K9974	N
7	LCD panel, 15.0-in. XGA <ul style="list-style-type: none"> • 1871-CTO, 22x, 23x, 24x, 25x, 26x, 27x, 86x • 1875-CTO, F4x, D3x, D9x, DAx, DCx, DMx, EAx, EBx, ECx, EDx • 1876-CTO, DBx, EEx, EFx 		
	LG	92P6699	N
	Samsung	92P6701	N
8	Clear plate	26R8409	N

15.0-in. SXGA+ IPS TFT

Note: Only supported by CTO.

No.	FRU	P/N	CRU ID
1	LCD cover kit, 15.0-in. (WW)	13R2917	N
2	Hinges, 15.0-in.	13R2918	N
3	LCD cable assembly, 15.0-in. SXGA+	91P6892	N
4	<i>Bluetooth</i> wireless antenna, 15.0-in.	91P6860	N
5	Antenna, 15.0-in.	91P6859	N
6	Inverter card, 15.0-in. IPS	27K9976	N
7	LCD panel, 15.0 SXGA+		
	ID TECH	92P6680	N
	LG	92P6761	N
8	Clear plate	26R8409	N

Keyboard

Keyboards for 15.0-in. LCD models

Language	P/N (NMB)	P/N (ALPS)	P/N (Chicony)	CRU ID
Arabic	39T0664	39T0725	39T0786	**
	93P4801	93P4861	13N9914	
Belgian	39T0659	39T0720	39T0781	
	93P4796	93P4856	13N9909	
Chinese, Traditional	39T0661	39T0722	39T0783	
	93P4798	93P4858	13N9911	
Czech	39T0665	39T0726	39T0787	
	93P4802	93P4862	13N9915	
Danish	39T0652	39T0713	39T0774	
	93P4789	93P4849	13N9902	
Dutch	39T0649	39T0710	39T0771	
	93P4786	93P4846	13N9899	
English, U.K.	39T0645	39T0706	39T0767	
	93P4782	93P4842	13N9895	
English, U.S.	39T0643	39T0704	39T0765	
	93P4780	93P4840	13N9893	
English, U.S. (International)	39T0672	—	—	
	91P9248	—	—	
French, Canadian	39T0646	39T0707	39T0768	
	93P4783	93P4843	13N9896	
French, Canadian (058)	39T0673	39T0733	39T0795	
	93P4809	93P4869	13N9923	
French, European	39T0648	39T0709	39T0770	
	93P4785	93P4845	13N9898	
German	39T0647	39T0708	39T0769	
	93P4784	93P4844	13N9897	
Greek	39T0667	39T0728	39T0789	
	93P4804	93P4864	13N9917	
Hungarian	39T0666	39T0727	39T0788	
	93P4803	93P4863	13N9916	
Hebrew	39T0663	39T0724	39T0785	
	93P4800	93P4860	13N9913	
Italian	39T0653	39T0714	39T0775	
	93P4790	93P4850	13N9903	

(continued)

Parts list

Language	P/N (NMB)	P/N (ALPS)	P/N (Chicony)	CRU ID
Japanese	39T0644	39T0705	39T0766	**
	93P4781	93P4841	13N9894	
Korean	39T0658	39T0719	39T0780	
	93P4795	93P4855	13N9908	
Norwegian	39T0651	39T0712	39T0773	
	93P4788	93P4848	13N9901	
Polish	39T0669	39T0730	39T0791	
	93P4806	93P4866	13N9919	
Portuguese	39T0656	39T0717	39T0778	
	93P4793	93P4853	13N9906	
Russian	39T0662	39T0723	39T0784	
	93P4799	93P4859	13N9912	
Slovak	39T0668	39T0729	39T0790	
	93P4805	93P4865	13N9918	
Slovenian	39T0670	39T0731	39T0792	
	93P4807	93P4867	13N9920	
Spanish, European	39T0654	39T0715	39T0776	
	93P4791	93P4851	13N9904	
Spanish, Latin American	39T0657	39T0718	39T0779	
	93P4794	93P4854	13N9907	
Swedish or Finnish	39T0650	39T0711	39T0772	
	93P4787	93P4847	13N9900	
Swiss	39T0655	39T0716	39T0777	
	93P4792	93P4852	13N9905	
Thai	39T0671	39T0732	39T0793	
	93P4808	93P4868	13N9921	
Turkish	39T0660	39T0721	39T0782	
	93P4797	93P4857	13N9910	

Keyboards for 14.1-in. LCD models

Language	P/N (NMB)	P/N (ALPS)	P/N (Chicony)	CRU ID
Arabic	39T0540	13N9978	39T0602	**
	08K5065	—	13N9852	
Belgian	39T0535	13N9973	39T0597	
	08K5060	—	13N9847	
Chinese, Traditional	39T0537	13N9975	39T0599	
	08K5062	—	13N9849	
Czech	39T0541	13N9979	39T0603	
	08K5066	—	13N9853	
Danish	39T0528	13N9966	39T0590	
	08K5053	—	13N9840	
Dutch	39T0525	13N9963	39T0587	
	08K5050	—	13N9837	
English, U.K.	39T0521	13N9959	39T0583	
	08K5046	—	13N9833	
English, U.S.	39T0519	13N9957	39T0581	
	08K5044	—	13N9831	
English, U.S. (International)	39T0548	—	—	
	93P4719	—	—	
French, Canadian	39T0522	13N9960	39T0584	
	08K5047	—	13N9834	
French, Canadian (058)	39T0549	13N9987	39T0611	
	93P4744	—	13N9861	
French, European	39T0524	13N9962	39T0586	
	08K5049	—	13N9836	
German	39T0523	13N9961	39T0585	
	08K5048	—	13N9835	
Greek	39T0543	13N9981	39T0605	
	08K5068	—	13N9855	
Hungarian	39T0542	13N9980	39T0604	
	08K5067	—	13N9854	
Hebrew	39T0539	13N9977	39T0601	
	93P4711	—	13N9851	
Italian	39T0529	13N9967	39T0591	
	08K5054	—	13N9841	
Japanese	39T0520	13N9958	39T0582	
	08K5045	—	13N9832	

(continued)

Parts list

Language	P/N (NMB)	P/N (ALPS)	P/N (Chicony)	CRU ID
Korean	39T0534	13N9972	39T0596	**
	08K5059	—	13N9846	
Norwegian	39T0527	13N9965	39T0589	
	08K5052	—	13N9839	
Polish	39T0545	13N9983	39T0607	
	08K5070	—	13N9857	
Portuguese	39T0532	13N9970	39T0594	
	08K5057	—	13N9844	
Russian	39T0538	13N9976	39T0600	
	08K5063	—	13N9850	
Slovak	39T0544	13N9982	39T0606	
	08K5069	—	13N9856	
Slovenian	39T0546	13N9984	39T0608	
	08K5071	—	13N9858	
Spanish, European	39T0530	13N9968	39T0592	
	08K5055	—	13N9842	
Spanish, Latin American	39T0533	13N9971	39T0595	
	08K5058	—	13N9845	
Swedish or Finnish	39T0526	13N9964	39T0588	
	08K5051	—	13N9838	
Swiss	39T0531	13N9969	39T0593	
	08K5056	—	13N9843	
Thai	39T0547	13N9985	39T0609	
	08K5072	—	13N9859	
Turkish	39T0536	13N9974	39T0598	
	08K5061	—	13N9848	

Recovery CDs

Windows XP Professional

Windows XP Professional is preinstalled as the operating system in the following models:

- 1871-1xx except 13x, 2xx, 4xx, 8xx, Cxx, Fxx
- 1872-1xx, 4xx, Cxx
- 1873-4Ax
- 1874-4Ax
- 1875-Dxx, Fxx

Language	P/N	CRU ID
Arabic	39K7811	*
Chinese, Simplified	39K7803	
Chinese, Traditional	39K7804	
Chinese, Traditional (Hong Kong S.A.R.)	39K7805	
Czech	39K7810	
Danish	39K7799	
Dutch	39K7802	
English, U.K.	39K7792	
English, U.S.	39K7791	
Finnish	39K7800	
French	39K7793	
German	39K7794	
Greek	39K7815	
Hebrew	39K7808	
Hungarian	39K7814	
Italian	39K7796	
Japanese	39K7806	
Korean	39K7807	
Norwegian	39K7801	
Polish	39K7809	
Portuguese, Brazilian	39K7797	
Russian	39K7812	
Spanish	39K7795	
Swedish	39K7798	
Turkish	39K7813	

Windows XP Home Edition

Windows XP Home Edition is preinstalled as the operating system in the following models:

- 1871-13x

Language	P/N	CRU ID
Arabic	39K8011	*
Chinese, Simplified	39K8003	
Chinese, Traditional	39K8004	
Chinese, Traditional (Hong Kong S.A.R.)	39K8005	
Czech	39K8010	
Danish	39K7999	
Dutch	39K8002	
English, U.K.	39K7992	
English, U.S.	39K7991	
Finnish	39K8000	
French	39K7993	
German	39K7994	
Greek	39K8015	
Hebrew	39K8008	
Hungarian	39K8014	
Italian	39K7996	
Japanese	39K8006	
Korean	39K8007	
Norwegian	39K8001	
Polish	39K8009	
Portuguese, Brazilian	39K7997	
Russian	39K8012	
Spanish	39K7995	
Swedish	39K7998	
Turkish	39K8013	

Miscellaneous parts

FRU	P/N	CRU ID
Screw kit (including nylon-coated screws): <ul style="list-style-type: none"> • M2 × 2.7 mm (silver), small head (10) • M2 × 3 mm (silver), small head (20) • M2 × 3 mm (from outside), pan head (10) • M2 × 4 mm (black), bind head (30) • M2 × 4 mm (black), small head (10) • M2 × 5 mm (gold), bind head (2) • M2 × 5 mm (black), flat head (20) • M2 × 10 mm (black), flat head (30) • M2 × 12 mm (black), flat head (5) • M2 × 14 mm (black), bind head (10) • M2 × 14 mm (black), TR7 (5) • M2 × 14.9 mm for drive bay (5) • M2 × 19 mm (black), bind head (5) • M2.5 × 3 mm (gold), flat head (5) • M2.5 × 4.8 mm (black), bind head (10) • M3 × 3 mm (PHILLIPS/slotted) (2) • Hex stud (5) • Security screw (1) • Screw caps (square, thin) • Screw caps (oval, not painted) • Screw caps (not painted) • Screw caps (square) • Tape on <i>Bluetooth</i> wireless antenna 	13R2916	N
Base miscellaneous parts (14.1-in. LCD models): <ul style="list-style-type: none"> • Cover, PC Card slot • Spacer, PC Card slot • Spring, PC Card slot cover • Rubber foot (rear) • Rubber foot (front) • Insulation sheet • Battery lock knob L • Battery lock latch L • Battery lock knob R • Battery lock latch R • Spring, battery lock • Slide lever • Slide lever spring • Pull lever • Pull lever spring • Puller • Rubber, shock absorber • Insulation, bottom • Foam under fan • Cu tape under fan • Cu tape • Insulation, louver • Screw caps (square, thin) 	26R8406	N

(continued)

Parts list

FRU	P/N	CRU ID
<p>Base miscellaneous parts (15.0-in. LCD models):</p> <ul style="list-style-type: none"> • Cover, PC Card slot • Spring, PC Card slot cover • Rubber foot (rear) • Rubber foot (front) • Battery lock knob L • Battery lock latch L • Battery lock knob R • Link, battery lock • Spring, battery lock • Slide lever • Slide lever spring • Pull lever • Pull lever spring • Puller • Rubber, shock absorber • Insulation sheet • Insulation, bottom • Foam under fan • Foam under system board, front • Foam under system board, rear • Cu plate, video • Insulation, louver • Screw caps (square, thin) 	26R8407	N
<p>System miscellaneous parts (14.1-in. LCD models):</p> <ul style="list-style-type: none"> • Cable, RJ11-docking connector on system board • DC in cable • <i>(c)</i> Hard disk drive guide rail • Spacer for DSP connector • <i>(e)</i> I/O plate bracket • <i>(f)</i> Support structure • Harness (left) • <i>(b)</i> Antenna cable guide • Bracket holder, LCD cable • <i>(d)</i> EMI spring, CDC • Connector bag • Screw cap (square, thin) <p>Note: Italicized letters in parentheses are references to the exploded view on page 185.</p>	26R8408	N

(continued)

FRU	P/N	CRU ID
System miscellaneous parts (15.0-in. LCD models): <ul style="list-style-type: none"> • Cable, RJ11-docking connector on system board • DC in cable • (c) Hard disk drive guide rail • Sheet for DSP connector • (e) I/O plate bracket • (f) Support structure • Harness (left) • (b) Antenna cable guide • Bracket holder, LCD cable • (d) EMI spring, CDC • Connector bag <p>Note: Italicized letters in parentheses are references to the exploded view on page 185.</p>	13R2915	N
System board miscellaneous parts: <ul style="list-style-type: none"> • Insulator, PC Card slot • Insulator, louver • Insulator, docking latch • Insulator, security chip • Insulator, docking connector • Insulator, fan • Insulator, Mg • S-video gasket • Form on system board • Insulator, louver, hard disk drive • Mic rubber • Stud, triangle • Audio connector bracket • Security chip spacer • Stud, system board • Screw cap (square, thin) 	26R8405	N

(continued)

FRU	P/N	CRU ID
LCD miscellaneous parts (14.1-in. LCD models): <ul style="list-style-type: none"> • Tape, LCD FPC • Tape on <i>Bluetooth</i> wireless antenna • (a) LCD latch R • (b) LCD latch L assembly • (c) Cable bushing (lower) • (d) Cable bushing (upper) • LED lens • Cable clip • Spiral tube • Screw caps (square, thin) • Screw caps (oval, not painted) • Screw caps (not painted) • Screw caps (square) <p>Note: Italicized letters in parentheses are references to the exploded view on page 194.</p>	13R2449	N

AC adapters

FRU	P/N	CRU ID
3-pin (72W) slim adapter for PFC model (models CTO, xxA, xxB, xxC, xxG, xxH, xxK, xxM, xxQ, xxV)		
ASTECC OP	92P1015	*
	08K8203	*
DELTA OP	92P1019	*
	08K8207	*
SANKEN OP	92P1023	*
	08K8211	*
2-pin (72W) slim adapter for non-PFC model (models CTO, xxE, xxF, xxJ, xxL, xxP, xxS, xxU, xxY)		
ASTECC OP	92P1017	*
	08K8205	*
DELTA OP	92P1021	*
	08K8209	*
SANKEN OP	92P1025	*
	08K8213	*

Optional FRUs

FRU	P/N	CRU ID
Hard disk drive, 80 GB, 9.5 mm, 4200 rpm, IBM STD	08K9863	*
Ultrabay Slim hard disk drive adapter	62P4553	*
Ultrabay Slim Li Polymer battery (2nd bay battery), Sanyo (WW)	08K8191	*
ThinkPad Dock II	67P9010	*
Top cover and screw kit for ThinkPad Dock II	46P3085	**
PCI cover for ThinkPad Dock II	46P3086	*
ThinkPad Mini Dock	67P9011	*
AC adapter (2 pin, 120 W), DELTA for ThinkPad Mini Dock	02K7086	*
AC adapter (2 pin, 120 W), LITEON for ThinkPad Mini Dock	02K7092	*
AC adapter (3 pin, 120 W), LITEON for ThinkPad Mini Dock	02K7094	*
AC adapter (3 pin, 120 W), LITEON for ThinkPad Mini Dock	02K7096	*
ThinkPad Port Replicator II	74P6735	*
ThinkPad Slim Drive Adapter for Ultrabay 2000	62P4556	*
Multiple battery charger	02K6642	*
Diskette drive cable	27L0525	*
Diskette drive (TEAC)	08K9606	*
Diskette drive (Sony)	08K9607	*

Common parts list

Tools

Tool	P/N
Triconnector wrap plug	72X8546
PC test card	35G4703
Audio wrap cable	66G5180
USB parallel test cable	05K2580
Screwdriver kit	95F3598
Mini PC tool set	00P7033
1/4" drive spinner handle	1650840
1/4" Sq. to 1/4" hex torx adapter	93F2838
TR7-TR-10 tamper resistant torx bits	00P6967
Removal tool antenna RF connector	08K7159
PCI-Express/USB wrap card	27K9813
USB floppy disk drive for maintenance diskette	05K9283
ThinkPad Hardware Maintenance Diskette Version 1.73 or later Note: Download the file from the following Web site: http://www.lenovo.com/think/spm	—

Power cords (system)

An IBM power cord for a specific country or region is usually available only in that country or region:

For 2-pin power cords:

Region	P/N	CRU ID
Canada, U.S. • models -CTO, xxF, xxL, xxS, xxU	13H5264	*
Japan • models -Exx, Jxx	74P4331	
Argentina • models -CTO, xxY	36L8870	
Brazil • models -CTO, xxP	49P2095	

For 3-pin power cords:

Region	P/N	CRU ID
Australia, New Zealand • models -CTO, xxG, xxM	76H3514	*
Taiwan, Thailand • models -CTO, xxV	76H3516	
Italy • models -CTO, xxG	76H3530	
Denmark • models -CTO, xxG	76H3520	
U.K., China (Hong Kong S.A.R.) • models -CTO, xxB, xxG, xxH	76H3524	
European countries • models -CTO, xxG	76H3518	
India, South Africa • models -CTO, xxG	76H3522	
Israel • models -CTO, xxG	76H3532	
Korea • models -xxK	76H3535	
China (P.R.C.) (other than Hong Kong S.A.R.) • models -xxC	02K0539	
Switzerland • models -CTO, xxG	76H3528	

Power cords (ThinkPad Dock II)

A ThinkPad power cord for a specific country or region is usually available only in that country or region:

For 3-pin power cords:

Region	P/N	CRU ID
Argentina	36L8868	*
Australia, New Zealand	75H8988	
Brazil	49P2101	
Canada, Thailand, U.S.	75H8989	
Denmark	75H8992	
European countries	75H8990	
India, South Africa	75H8993	
Israel	75H8999	
Italy	75H8998	
Japan	75H8996	
Korea	76H3536	
China (P.R.C.) (other than Hong Kong S.A.R)	02K0540	
Switzerland	75H8997	
U.K.	75H8994	

Notices

Lenovo may not offer the products, services, or features discussed in this document in all countries. Consult your local Lenovo representative for information on the products and services currently available in your area. Any reference to a Lenovo product, program, or service is not intended to state or imply that only that Lenovo product, program, or service may be used. Any functionally equivalent product, program, or service that does not infringe any Lenovo intellectual property right may be used instead. However, it is the user's responsibility to evaluate and verify the operation of any other product, program, or service.

Lenovo may have patents or pending patent applications covering subject matter described in this document. The furnishing of this document does not give you any license to these patents. You can send license inquiries, in writing, to:

*Lenovo (United States), Inc.
500 Park Offices Drive, Hwy. 54
Research Triangle Park, NC 27709
U.S.A.
Attention: Lenovo Director of Licensing*

LENOVO GROUP LTD. PROVIDES THIS PUBLICATION "AS IS" WITHOUT WARRANTY OF ANY KIND, EITHER EXPRESS OR IMPLIED, INCLUDING, BUT NOT LIMITED TO, THE IMPLIED WARRANTIES OF NON-INFRINGEMENT, MERCHANTABILITY OR FITNESS FOR A PARTICULAR PURPOSE. Some jurisdictions do not allow disclaimer of express or implied warranties in certain transactions, therefore, this statement may not apply to you.

This information could include technical inaccuracies or typographical errors. Changes are periodically made to the information herein; these changes will be incorporated in new editions of the publication. Lenovo may make improvements and/or changes in the product(s) and/or the program(s) described in this publication at any time without notice.

The products described in this document are not intended for use in implantation or other life support applications where malfunction may result in injury or death to persons. The information contained in this document does not affect or change Lenovo product specifications or warranties. Nothing in this document shall operate as an express or implied license or indemnity under the intellectual property rights of Lenovo or third parties. All information contained in this document was obtained in specific environments

Notices

and is presented as an illustration. The result obtained in other operating environments may vary.

Lenovo may use or distribute any of the information you supply in any way it believes appropriate without incurring any obligation to you.

Any references in this publication to non-Lenovo Web sites are provided for convenience only and do not in any manner serve as an endorsement of those Web sites. The materials at those Web sites are not part of the materials for this Lenovo product, and use of those Web sites is at your own risk.

Any performance data contained herein was determined in a controlled environment. Therefore, the result obtained in other operating environments may vary significantly. Some measurements may have been made on development-level systems and there is no guarantee that these measurements will be the same on generally available systems. Furthermore, some measurements may have been estimated through extrapolation. Actual results may vary. Users of this document should verify the applicable data for their specific environment.

Trademarks

The following terms are trademarks of Lenovo in the United States, other countries or both:

- Lenovo
- Rescue and Recovery
- ThinkLight
- ThinkPad
- ThinkPad Dock II
- ThinkPad Mini Dock
- ThinkPad Port Replicator
- ThinkPad Port Replicator II
- TrackPoint
- Ultrabay
- Ultrabay 2000
- Ultrabay Plus
- UltraNav

The following terms are trademarks of the International Business Machines Corporation in the United States, other countries, or both:

- IBM (used under license)
- OS/2

Microsoft, Windows, and Windows NT are trademarks of Microsoft Corporation in the United States, other countries, or both.

Intel and Pentium are trademarks or registered trademarks of Intel Corporation or its subsidiaries in the United States and other countries.

Other company, product, or service names may be the trademarks or service marks of others.

Part Number: 39T6193

(1P) P/N: 39T6193

