 QUANTA COMPUTER		
Title: Schematic Block Diagram2		
Size: JMZ	Document Number:	Rev: 1A
Date: Monday, January 06, 2003	Sheet: 2	of 49

INDEX

Pg#	Description	DNI LIST
1	Schematic Block Diagram 1	
2	Schematic Block Diagram 2	
3	FRONTPAGE	
4-5	Banias	
6-8	Odem MCH-M	
9-11	ICH4	
12-13	DDR SO-DIMM(200P)	
14	CLOCK GENERATOR	
15-17	M7/M9 Graphics	
18-19	LCD CONN,CY25245 & CRT CONN	
20	IDE (HDD&CD_ROM)	
21	PAD& SCREW	
22	O2_OZ711E1&CONN	
23-24	MINI-PCI & MDC CONN	
25-26	SIO	
27-28	SERIAL & PARALLEL	
29	FLASH	
30-31	TOUCH PAD & SWITCH&LED	
32	FAN & THERMAL	
33-34	AC97 CODEC & connector	
35-36	LAN(KENAI32-LAVON) & JACK	
37	FIR	
38-39	DOCKING Buffer and connector	
40	Reset circuit	
41	RTC BATTERY	
42-43	Battery Selector & Charger	
44	CPU Power	
45	1.2V,1.5V,1.8VS.2.5VS	
46	D/D Power	
47	RUN POWER SW	
48	VGA DC/DC	
49	DCIN,Batt	
50	CPU I/O Power	

Power & Ground

Label	Pg#	Description	Control Signal
DC_IN+		AC ADAPTER (20V)	
PBATT+		MAIN BATTERY +(10-17V)	
PWR_SRC		MAIN POWER (10-20V)	
RTC_PWR3_3V		RTC & PCL POWER (3_3V)	
+12V		+12V	DRUNPWROK
VHCORE		CPU CORE POWER (1.25/1.15V)	RUNPWROK
V1_2RUN		AGTL+ POWER (1.2V)	RUNPWROK
+3VRUN		SLP_S3# CTRLD POWER	RUN_ON
+3VSUS		SLP_S5# CTRLD POWER	SUS_ON
+5VALW		8051 POWER (5V)	
+5VRUN		SLP_S3# CTRLD POWER	RUN_ON
+5VSUS		SLP_S5# CTRLD POWER	SUS_ON
+5VHDD		HDD POWER (5V)	HDDC_EN#
+5VMOD		MODULE POWER (5V)	MODC_EN#
STRB#5V		EXTERNAL FDD POWER (5V)	FDD/LPT#
+5VFAN1, +5VFAN2		FAN POWER (5V)	FAN_OFF/ON#
VDDA		AUDIO ANALOG POWER (5V)	RUN_ON
1_8VSUS		RESUME WELL IN ICH	
1_8VRUN		SLP_S3# CTRLD POWER	
+3VALW		8051 POWER (3V)	
V1_5RUN		AGP I/O POWER	
 GND	ALL PAGES	DIGITAL GROUND	
 AGND		AUDIO GND	
 GNDP		CPU POWER GND	
 CGNDP		CHARGER GND	
 DGNDP		DC/DC POWER GND	
 LANGND		COMBO CONN GND	

 **QUANTA
COMPUTER**

Title: Index, DNI, Power & Ground

Size: Document Number JMZ Rev 1A

Date: Monday, January 06, 2003 Sheet 3 of 49

R867 should be close to ICH4

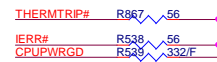
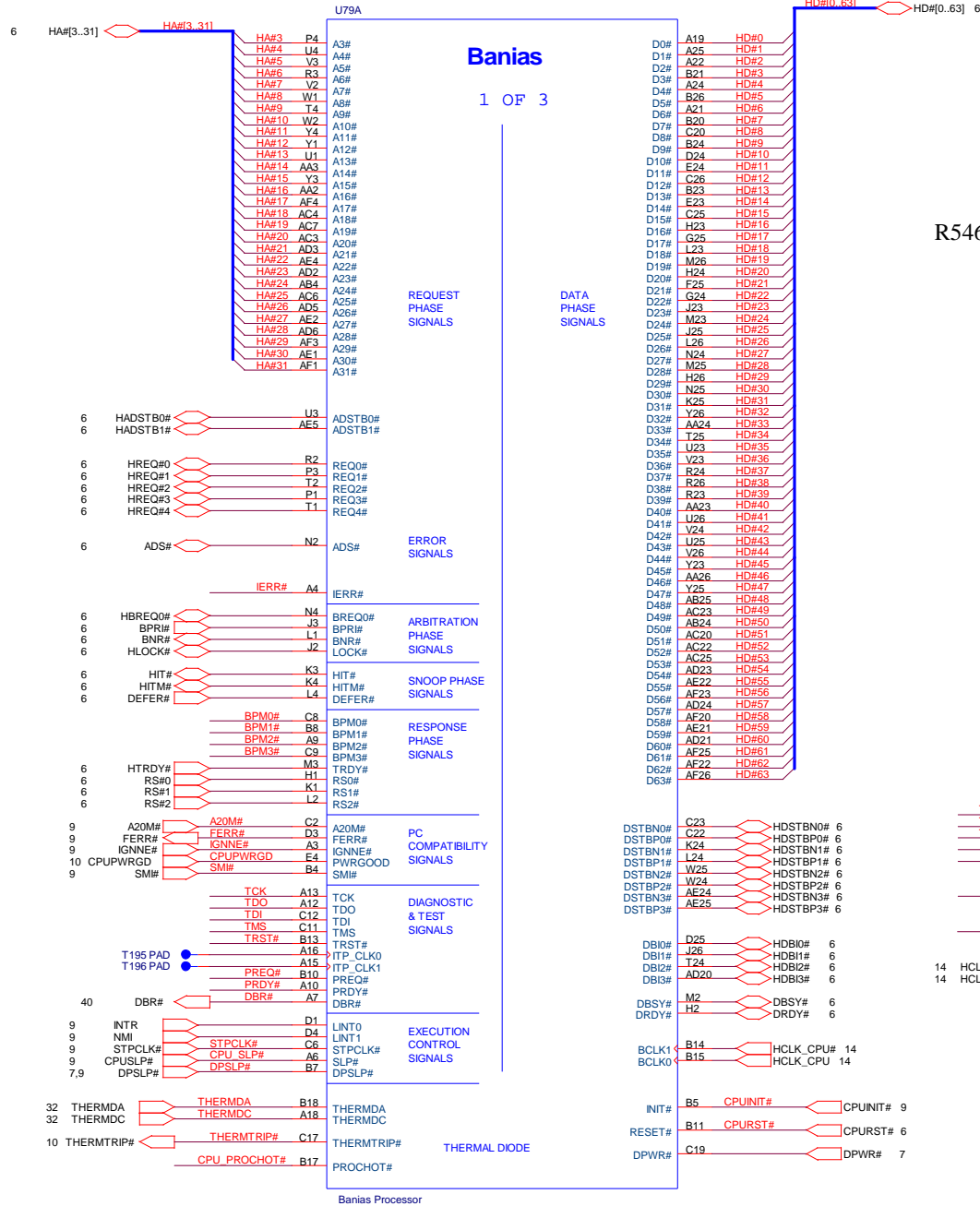

R546 should be place within 2" of the processor ; others place near ITP

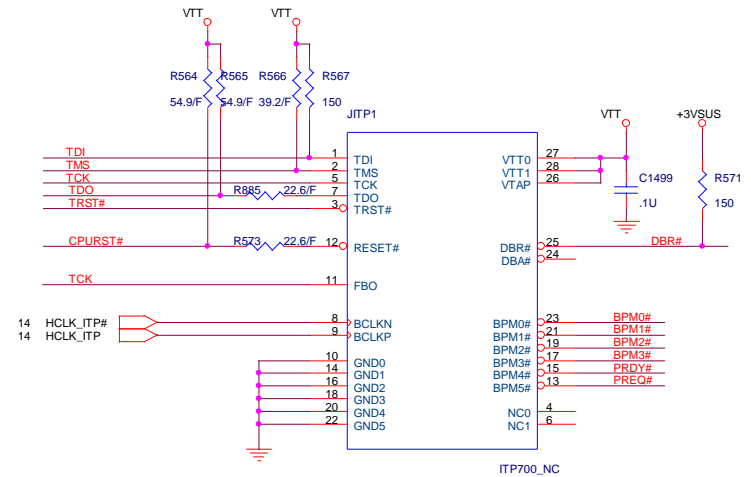
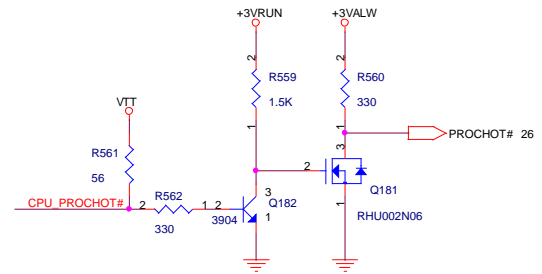

QUANTA COMPUTER

Title: Banias Processor (HOST)

Size: Document Number JM2

Date: Monday, January 06, 2003

Sheet 4 of 49

Rev 1A

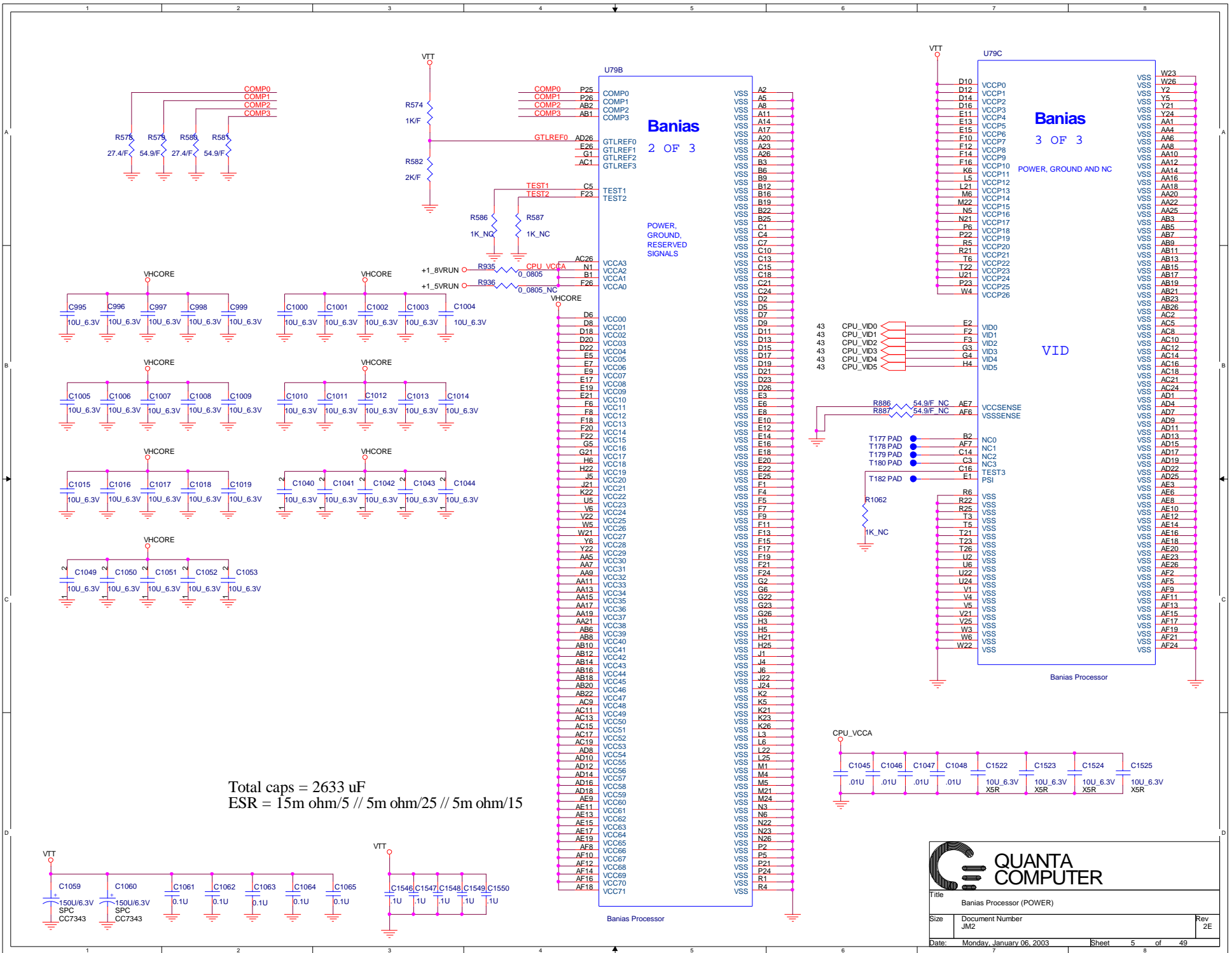

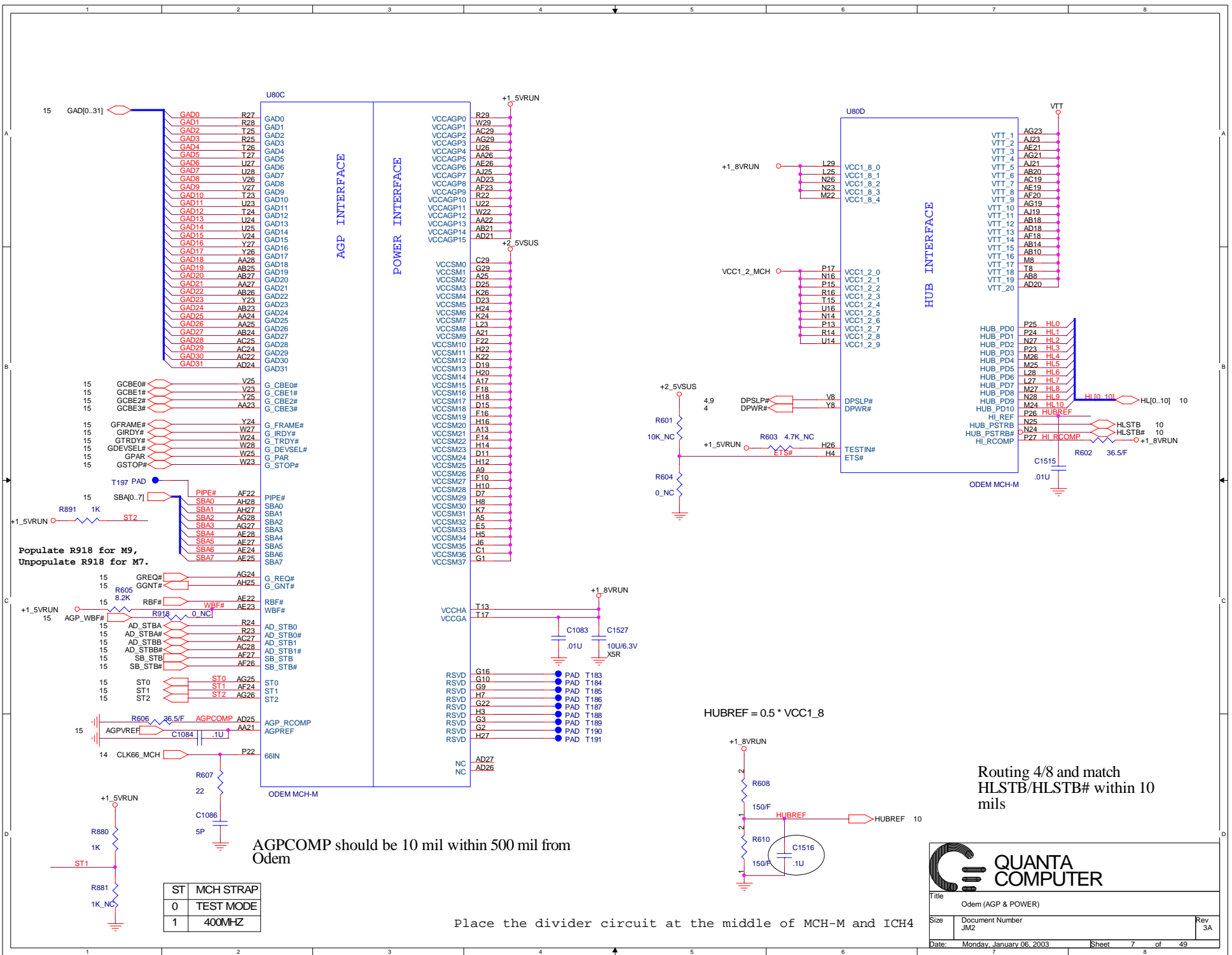

QUANTA COMPUTER

Title: Odem (AGP & POWER)

Size: Document Number JM2

Date: Monday, January 06, 2003

Sheet: 7 of 49

Rev: 3A

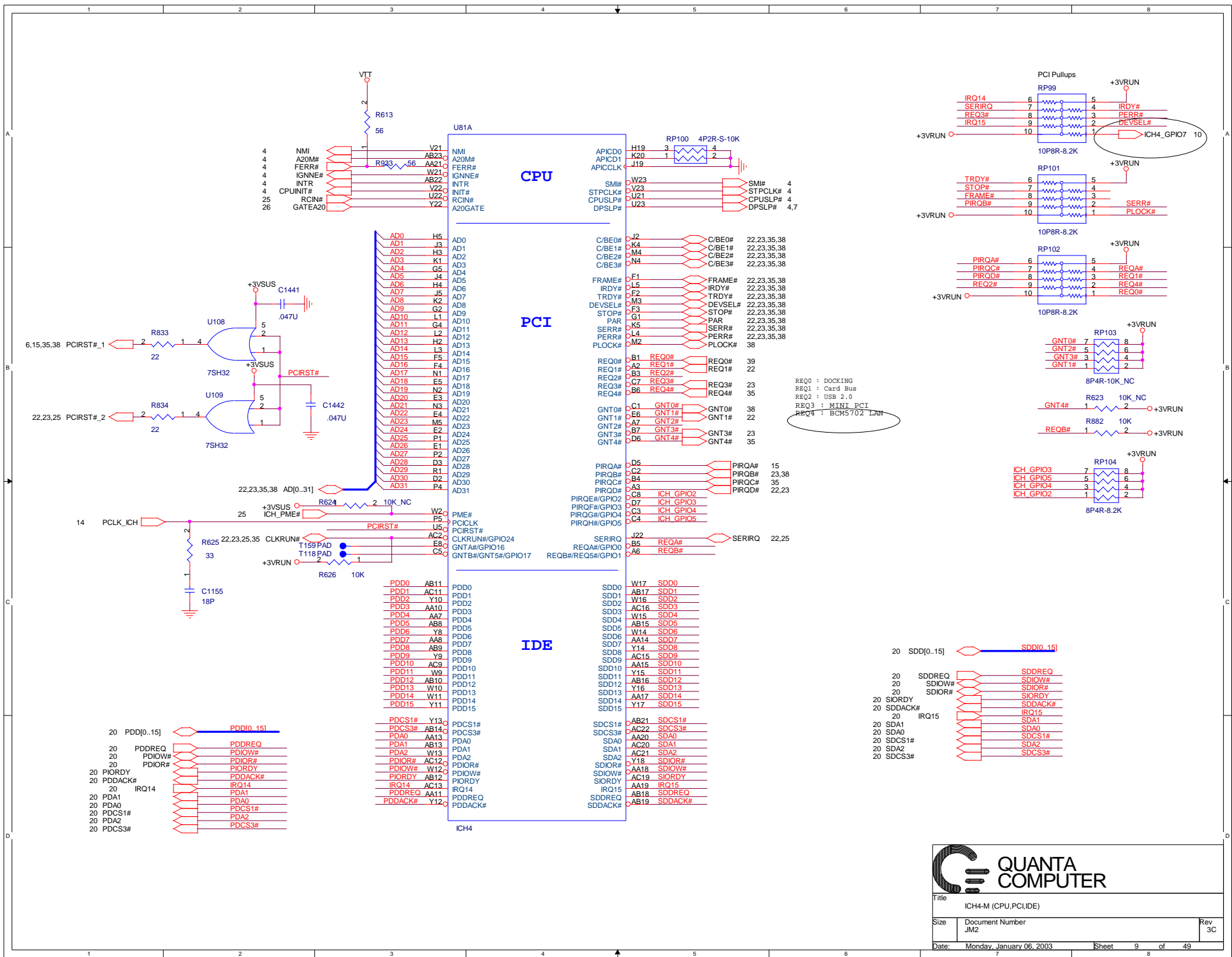

QUANTA COMPUTER

Title: ICH4-M (CPU,PCLIDE)

Size: Document Number JM2 Rev 3C

Date: Monday, January 06, 2003 Sheet 9 of 49

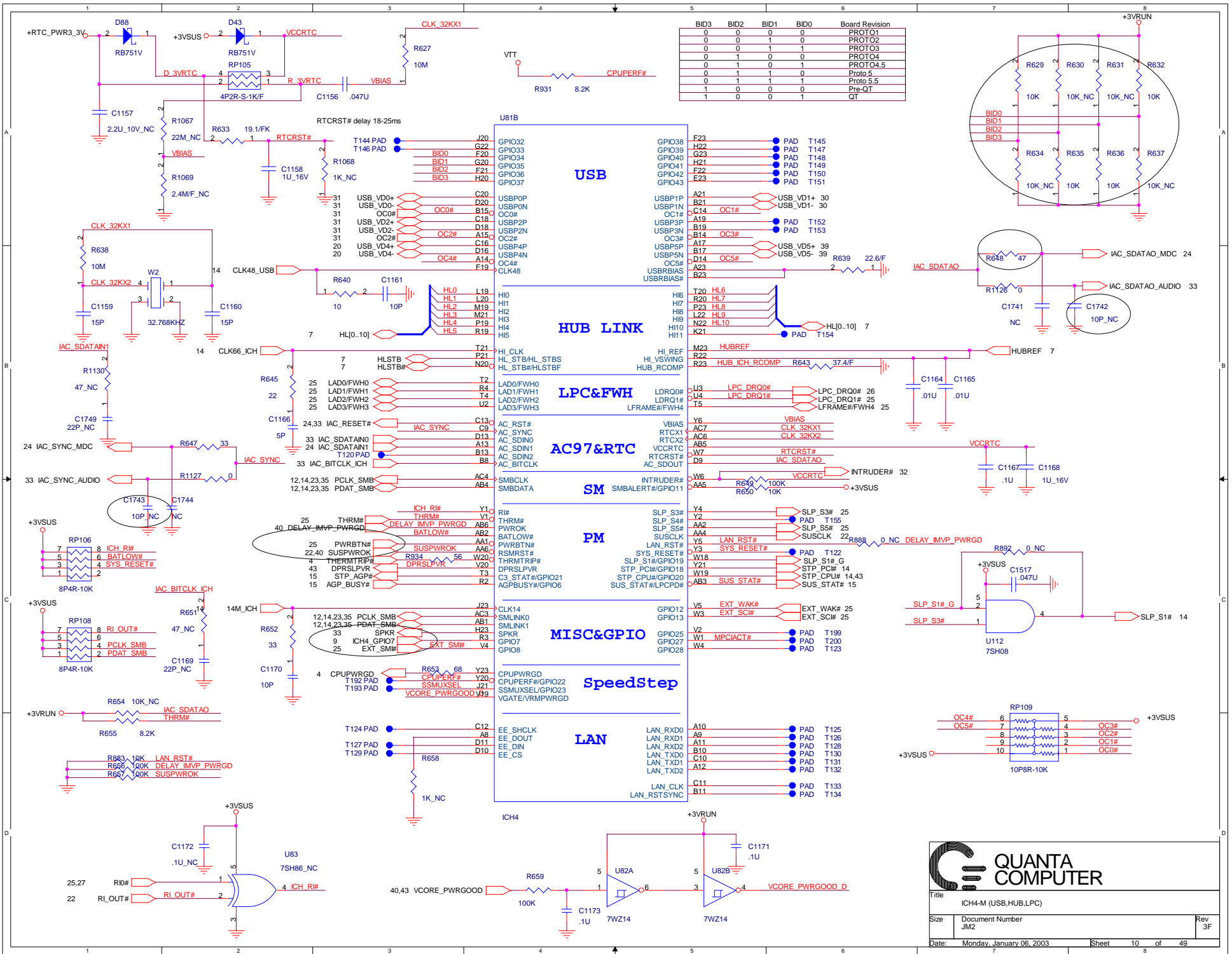

QUANTA COMPUTER

Title: ICH4-M (USB,HUB,LPC)

Size: Document Number JM2

Date: Monday, January 06, 2003

Sheet 10 of 49

Rev 3F

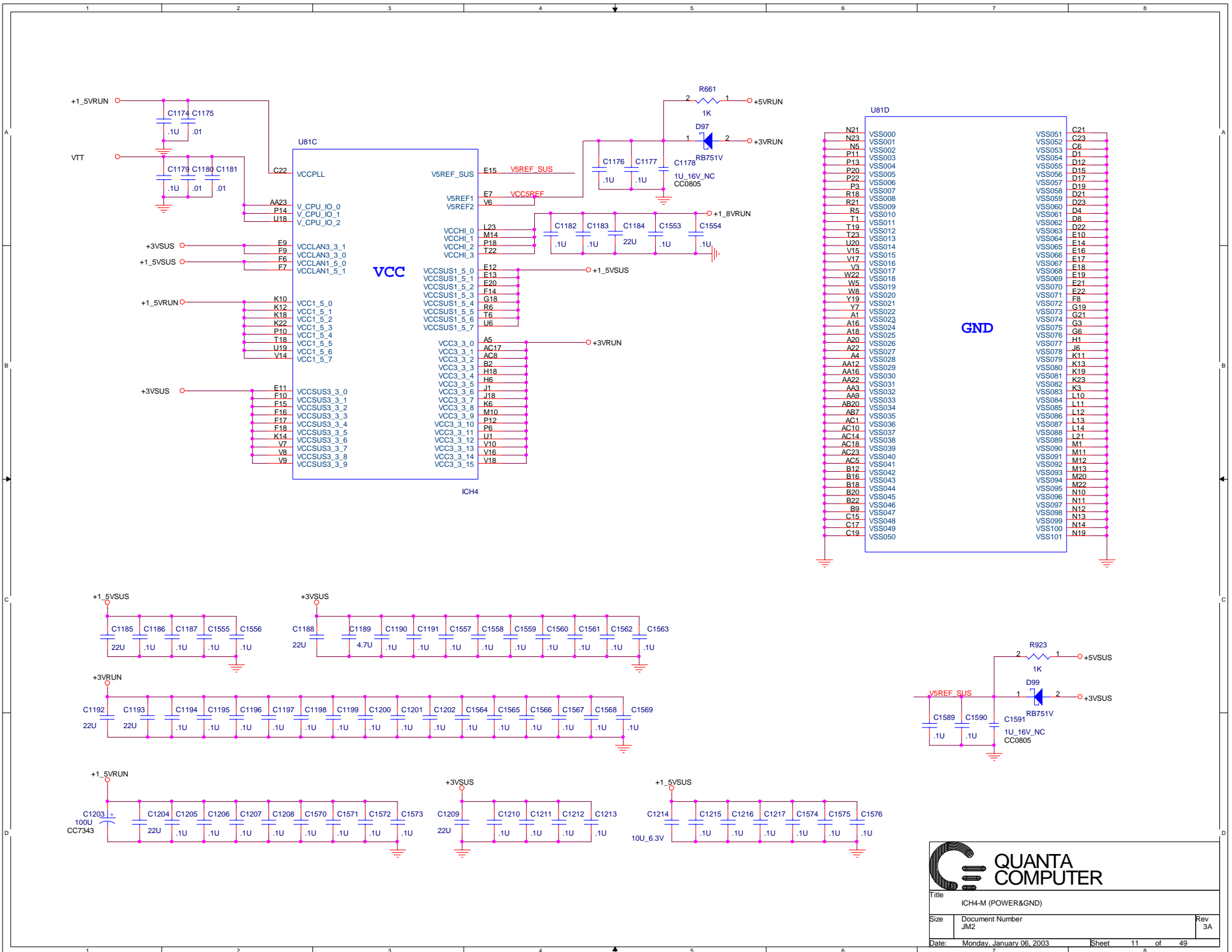

QUANTA COMPUTER

Title: ICH4-M (POWER&GND)

Size: JM2 | Document Number: | Rev: 3A

Date: Monday, January 06, 2003 | Sheet: 11 of 49

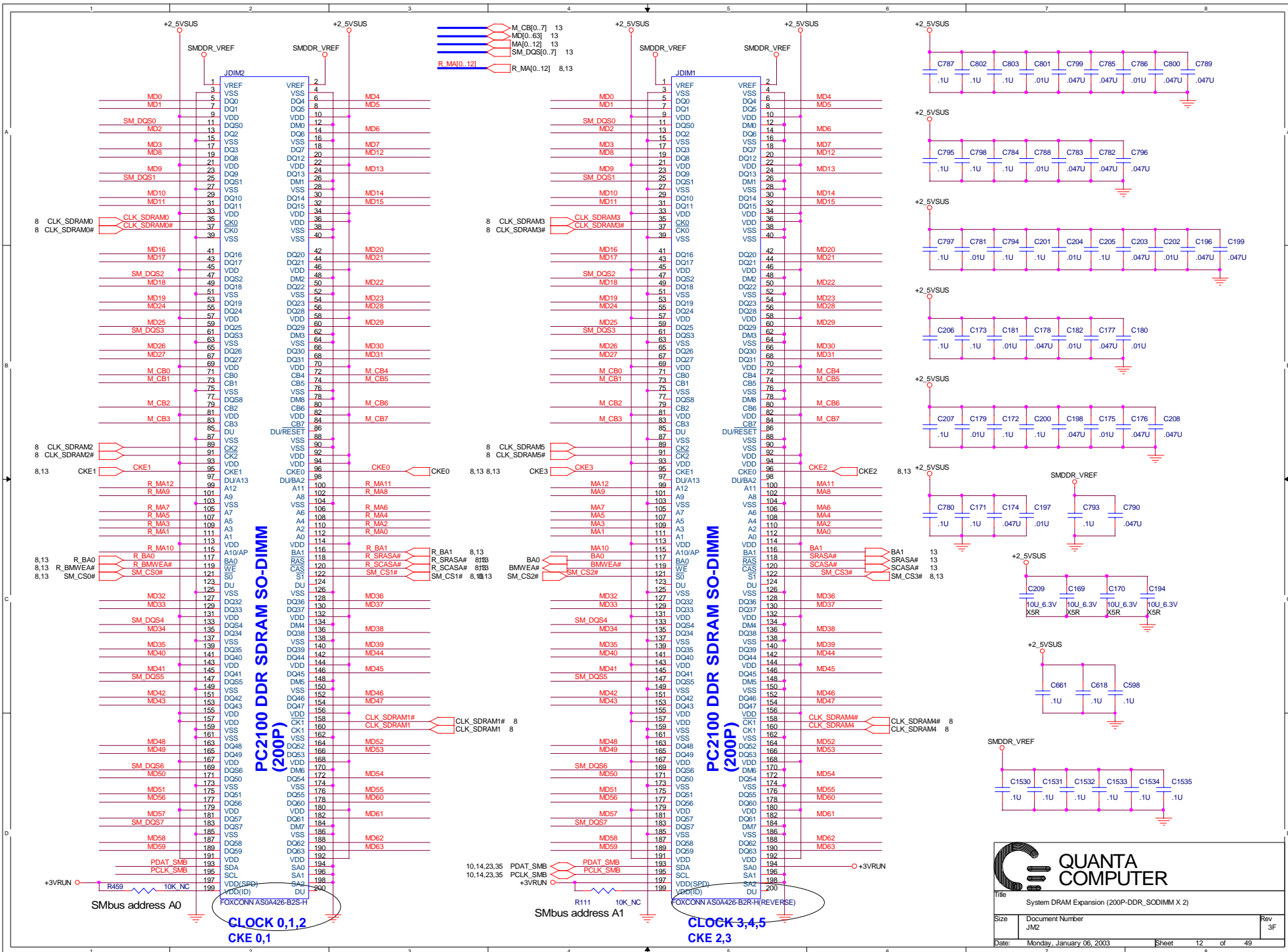

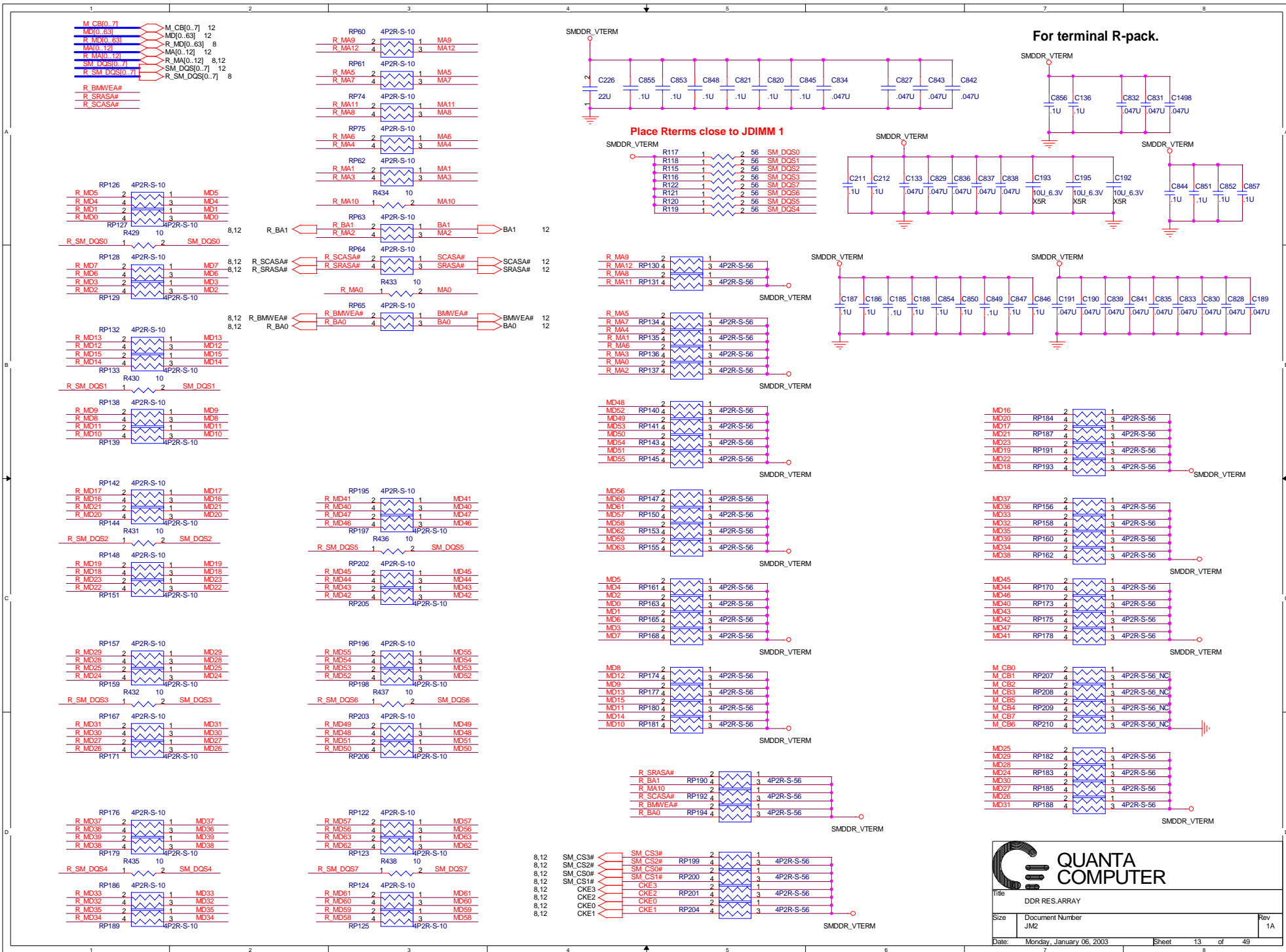

S2	S1	S0	CPU	3V66[0..4]	3V66_5/66IN
1	0	0	66	66IN	66 Input
1	0	1	100	66IN	66 Input
1	1	0	200	66IN	66 Input
1	1	1	133	66IN	66 Input
0	0	0	66	66	66 Input
0	0	1	100	66	66 Input
0	1	0	200	66	66 Input
0	1	1	133	66	66 Input

Place these termination to close CK408.

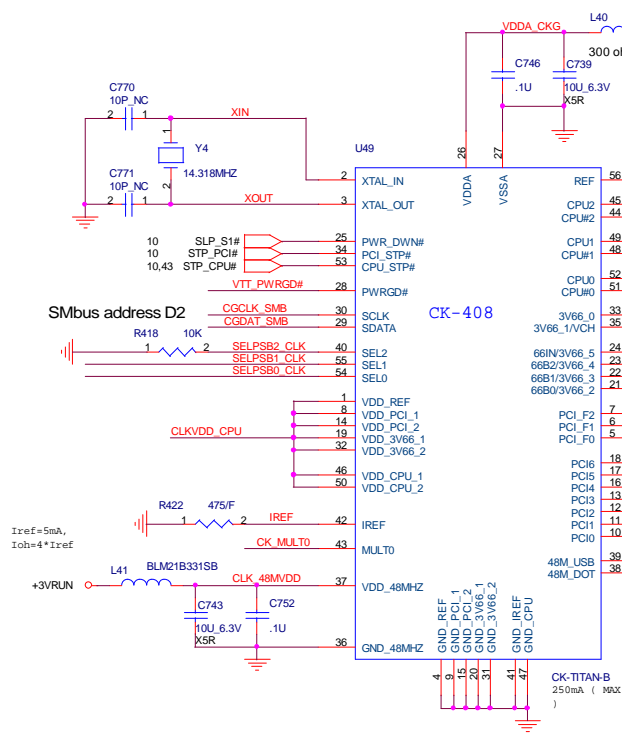
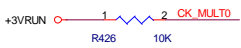
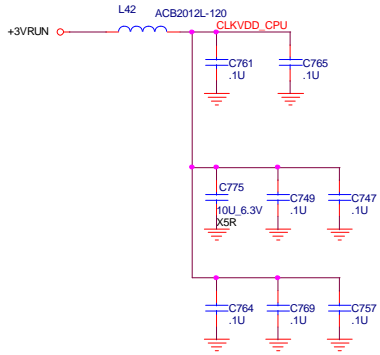

SMbus address D2

$I_{ref}=5mA$,
 $I_{ob}=4*I_{ref}$

These are for backdrive issue

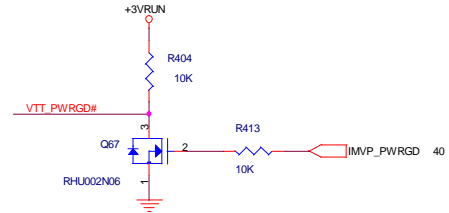

QUANTA COMPUTER

Title: CLOCK GENERATOR

Size: Document Number JMZ Rev 1A

Date: Monday, January 06, 2003 Sheet 14 of 49

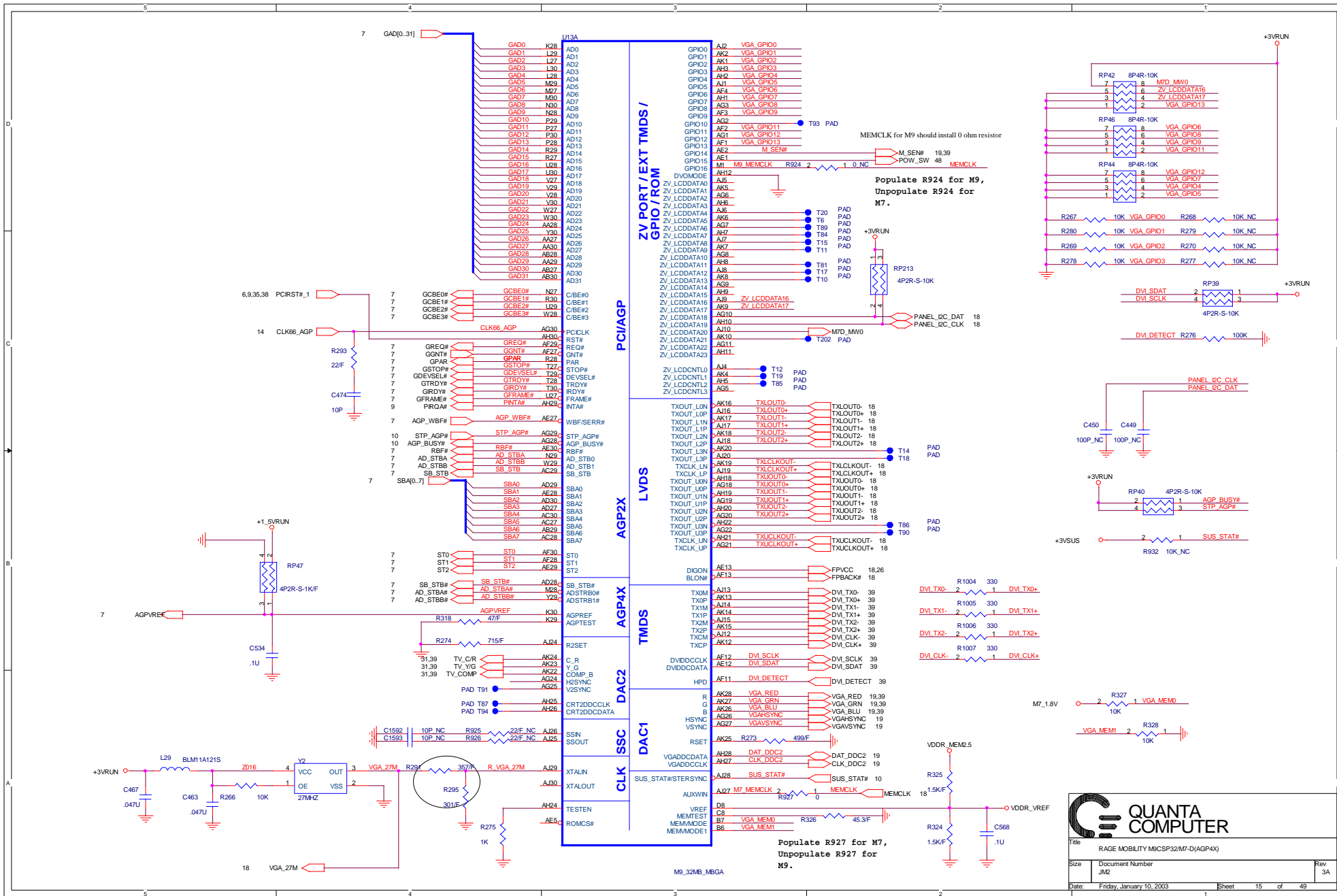

QUANTA COMPUTER

Title: RAGE MOBILITY M9CS32/M7-D(AGP4X)

Size: Document Number

Date: Friday, January 10, 2003

Sheet 15 of 49

Rev 3A

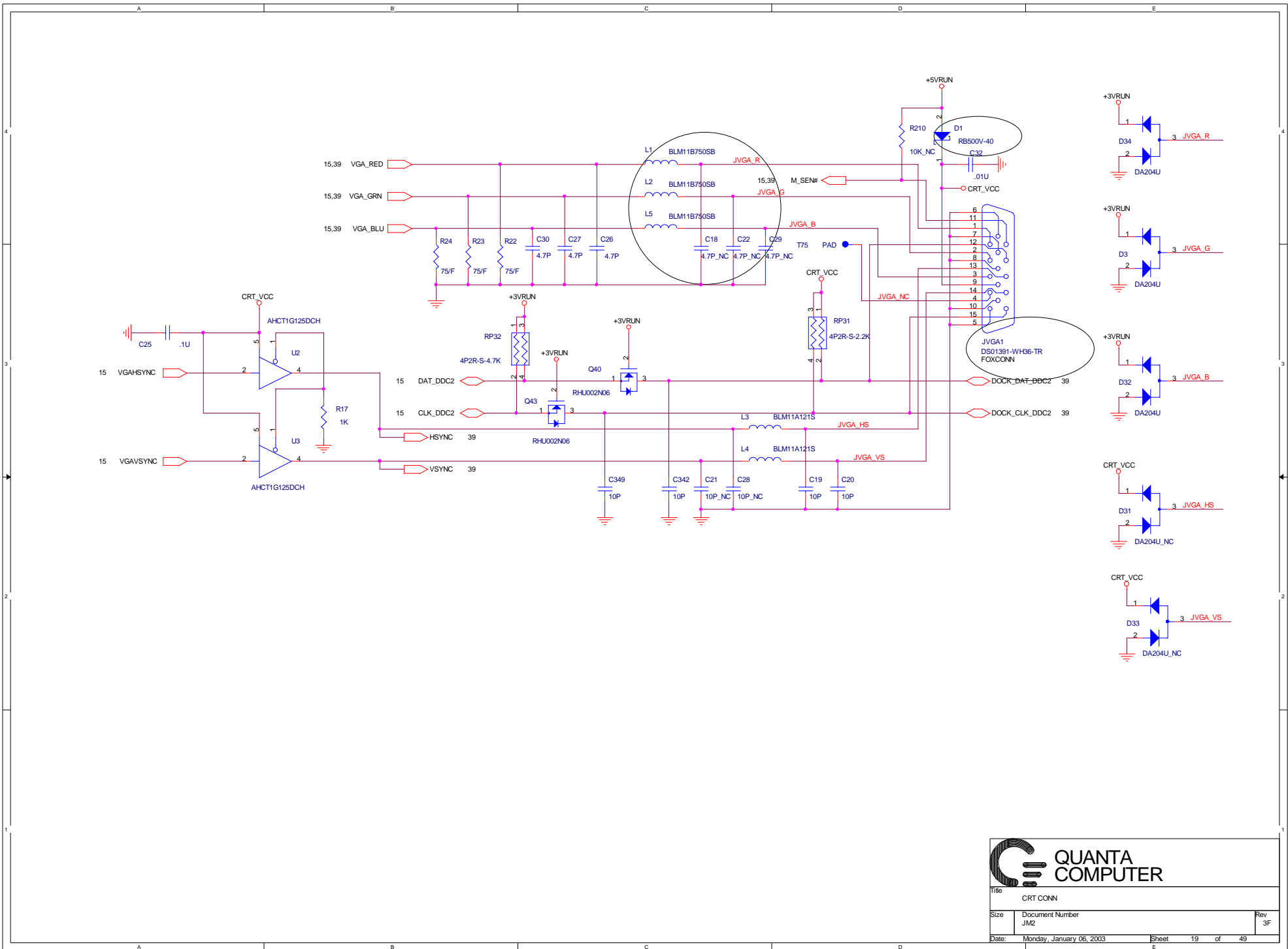

QUANTA COMPUTER

Title: CRT CONN

Size: Document Number JM2 Rev: 3F

Date: Monday, January 06, 2003 Sheet: 19 of 49

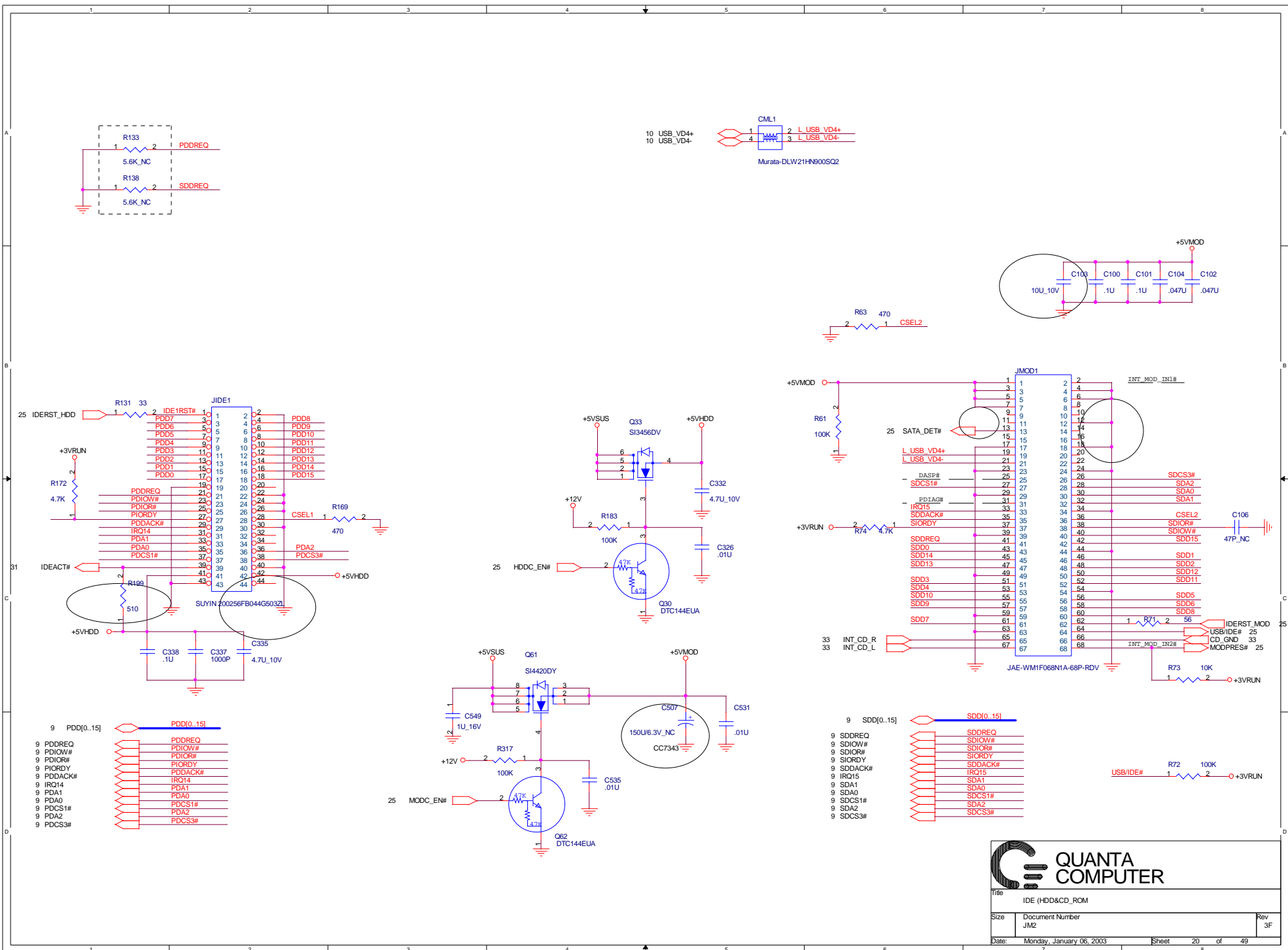

QUANTA COMPUTER

Title: IDE (HDD&CD_ROM)

Size	Document Number	Rev
	JM2	3F

Date: Monday, January 06, 2003 Sheet 20 of 49

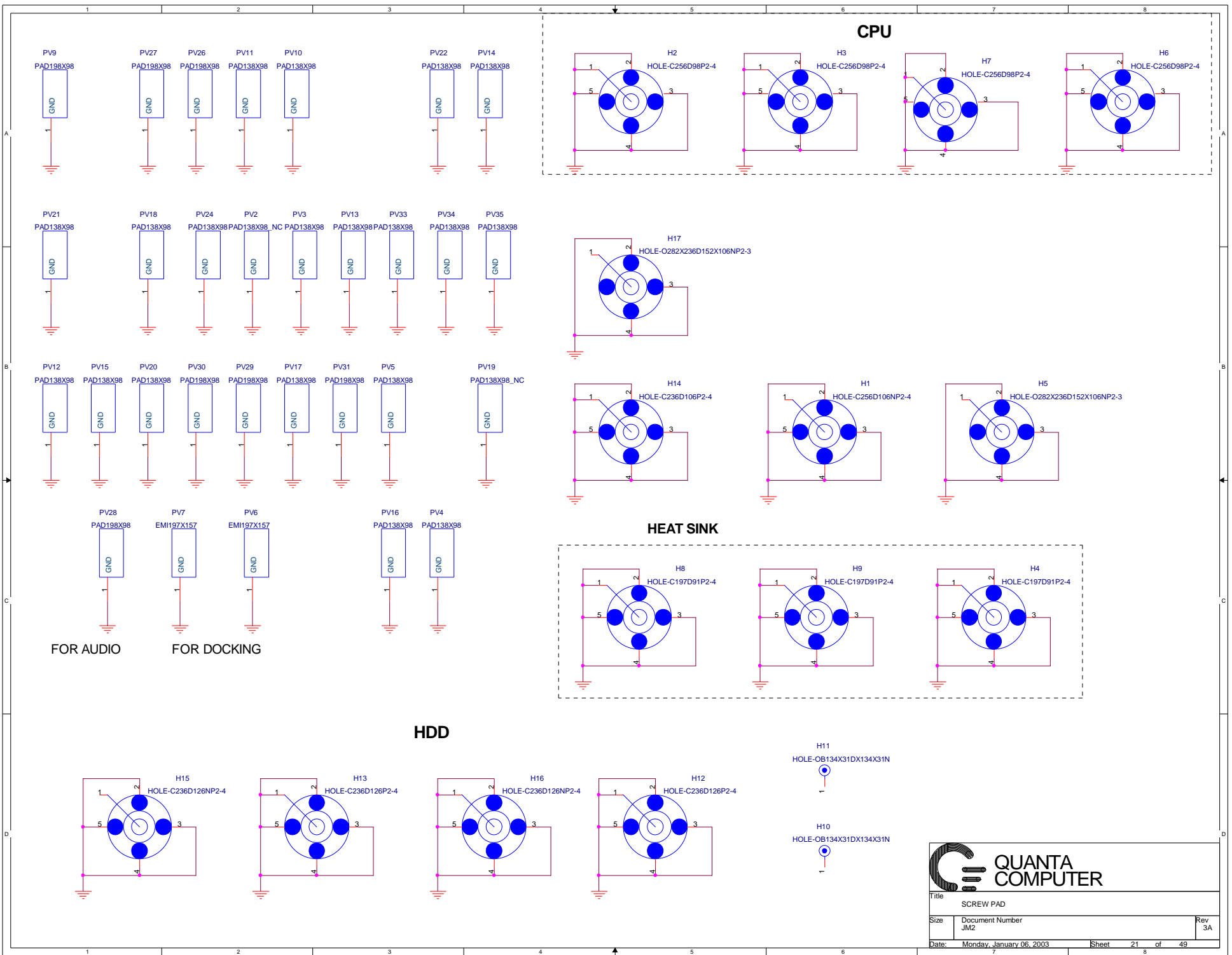

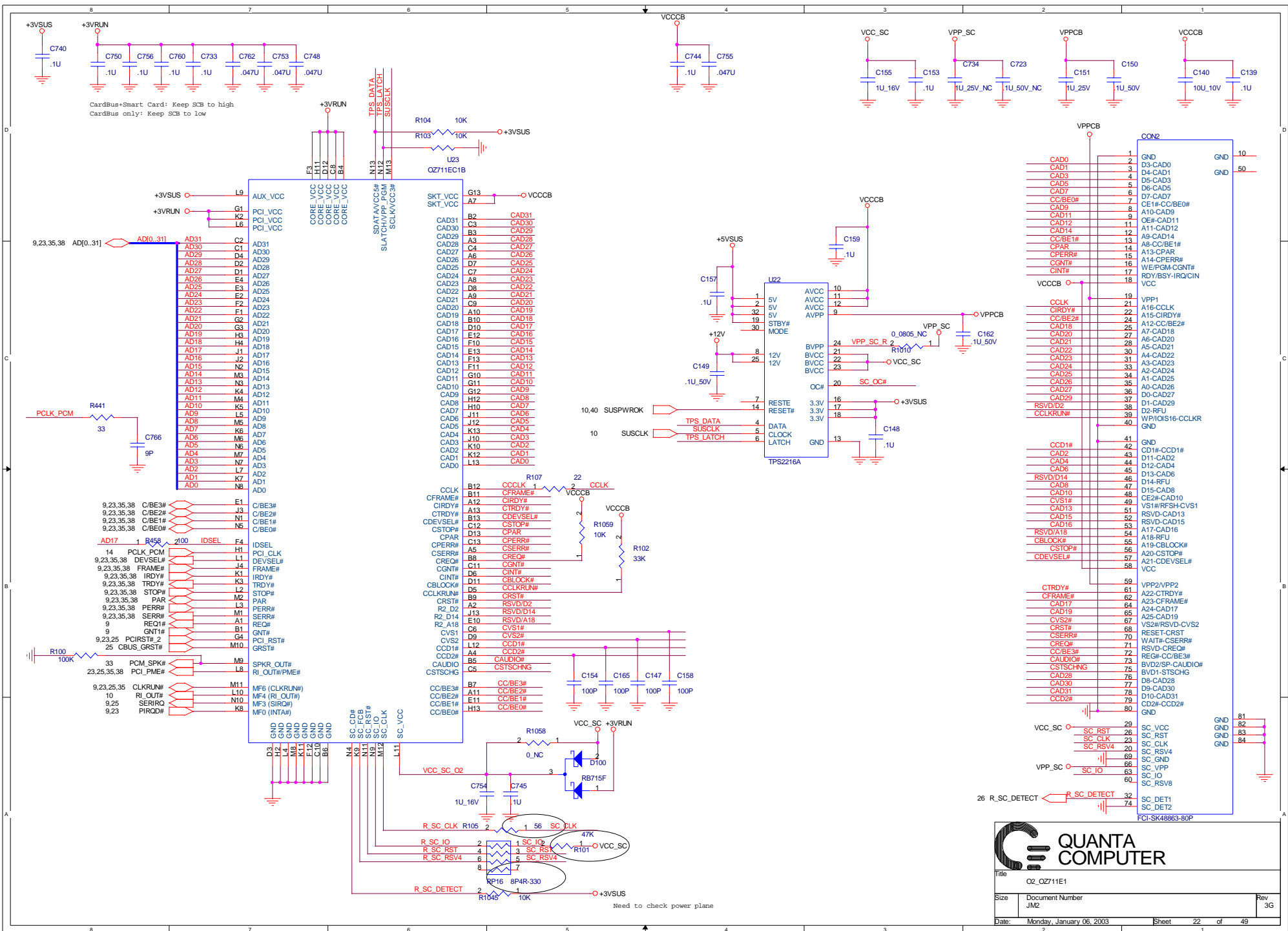

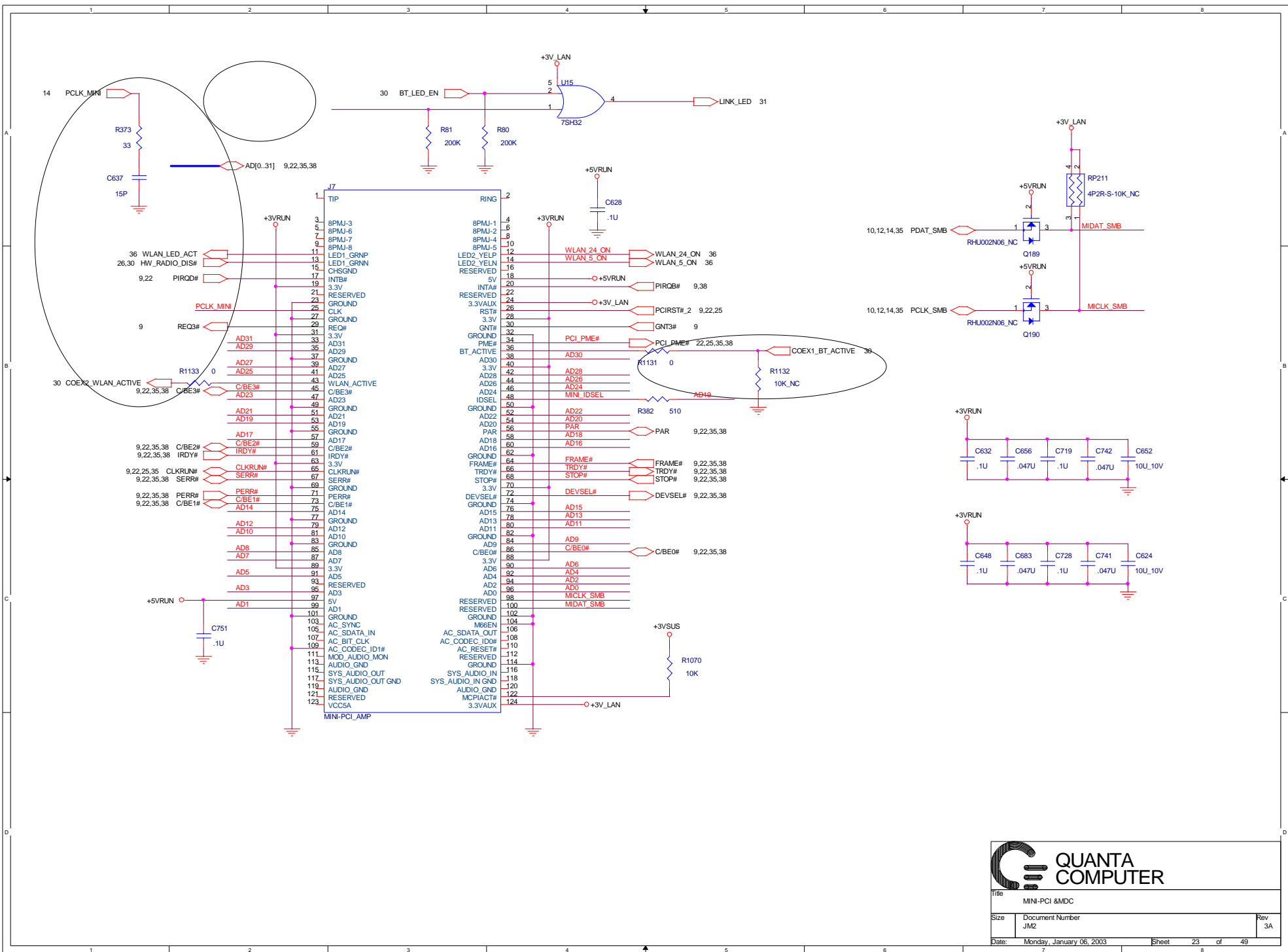

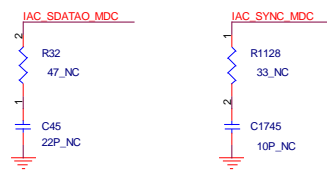
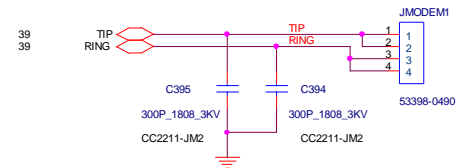
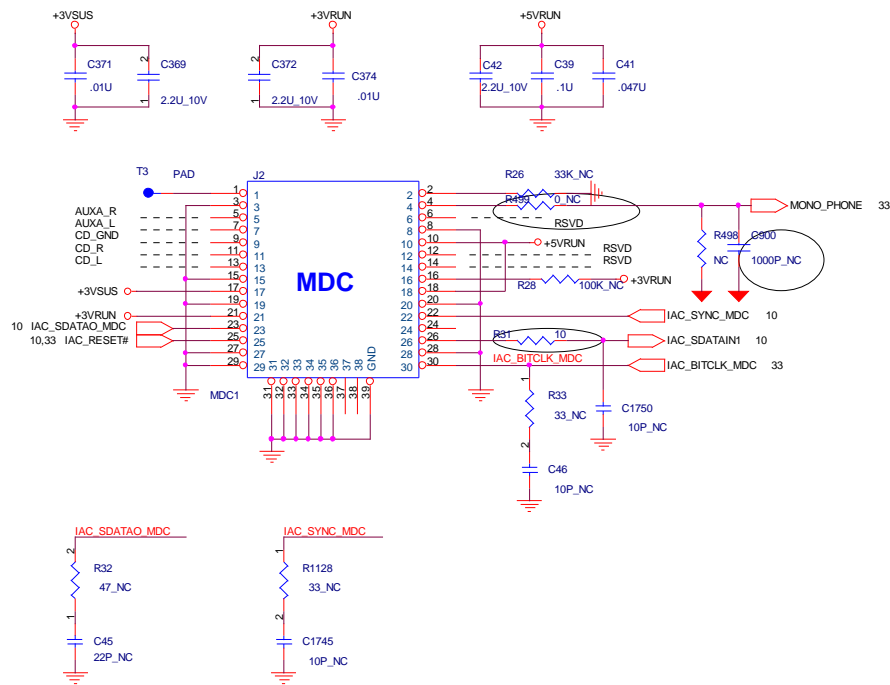

QUANTA COMPUTER

Title: MDC CONN.

Size: JM2	Document Number: JM2	Rev: 3A
-----------	----------------------	---------

Date: Monday, January 06, 2003 Sheet: 24 of 49

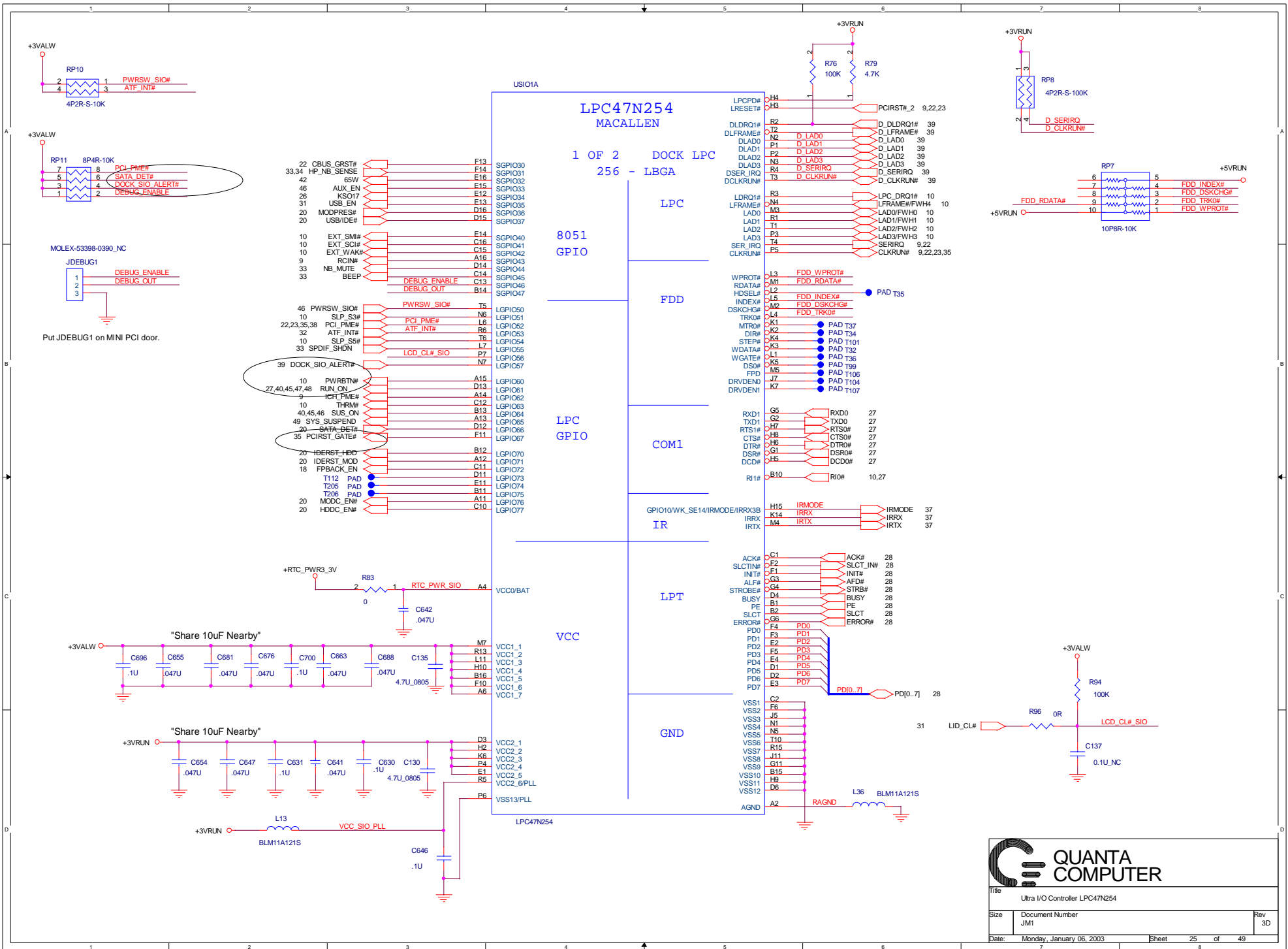

QUANTA COMPUTER

Title: Ultra I/O Controller LPC47N254

Size	Document Number	Rev
	JM1	3D

Date: Monday, January 06, 2003 Sheet 25 of 49

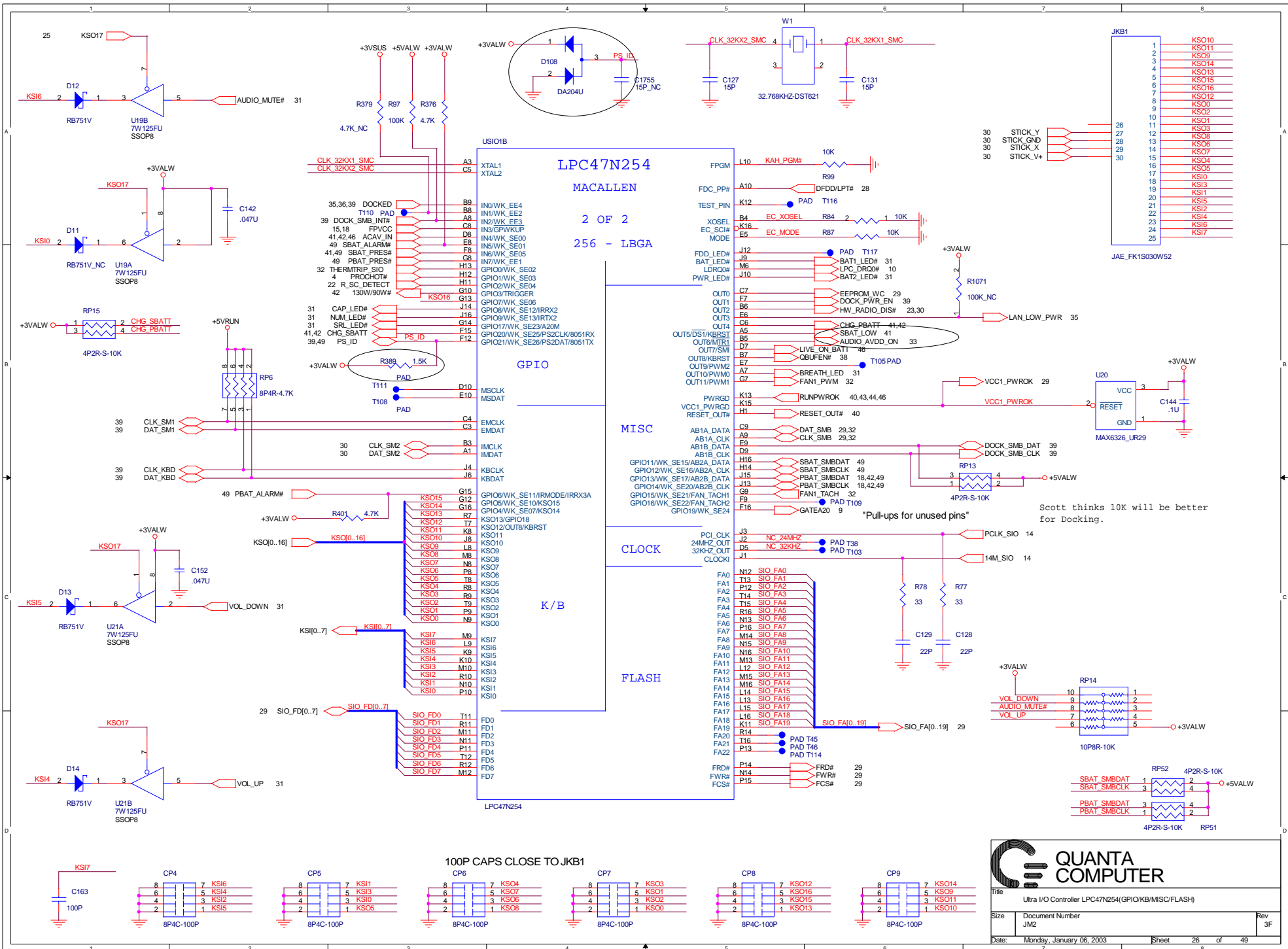

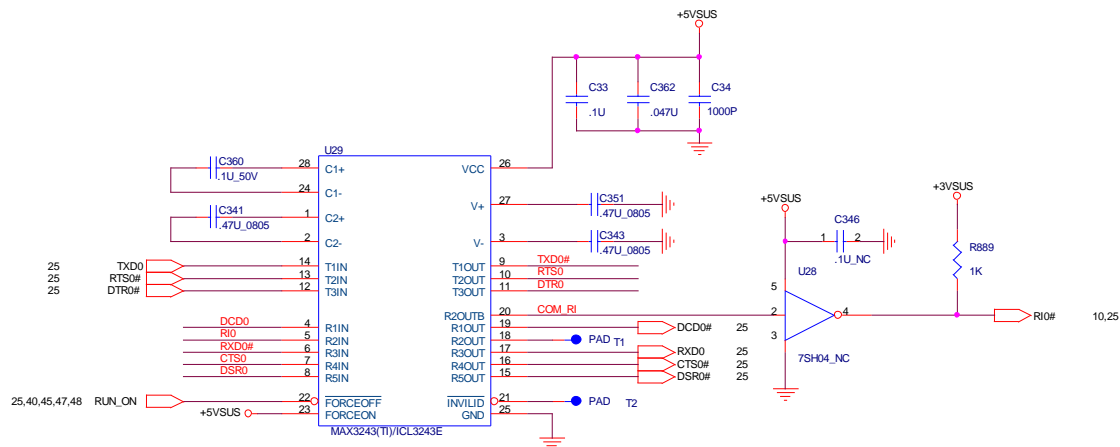

If MAX3243 pin 22 tied to RUN_ON, then it can not support Ring Out

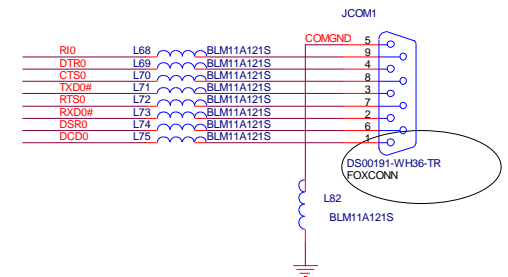

Place these beads close to JCOM1 as soon as possible

QUANTA COMPUTER

Title: SERIAL PORT

Size: Document Number JM2 Rev: 3F

Date: Monday, January 06, 2003 Sheet: 27 of 49

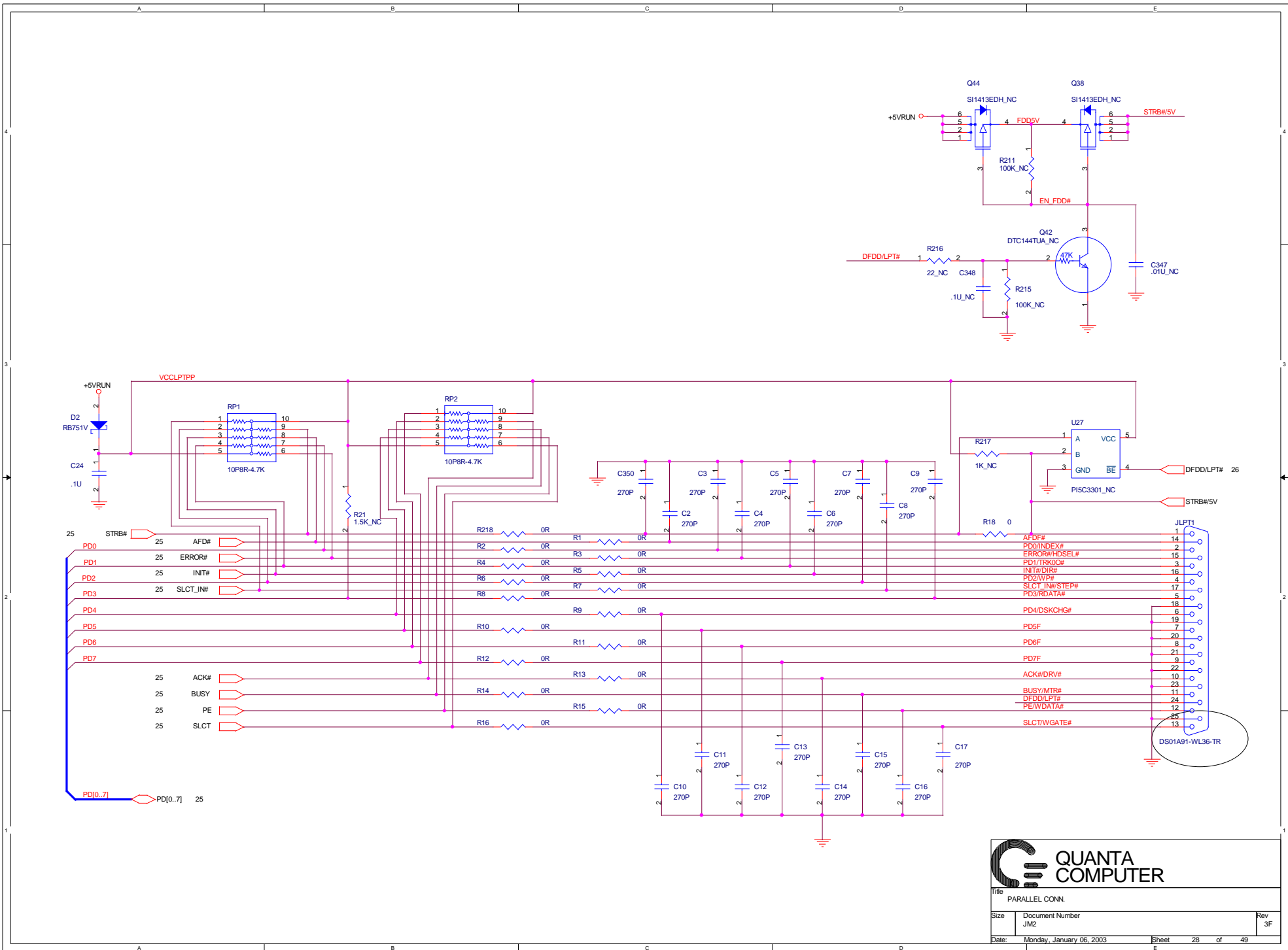

QUANTA COMPUTER

Title: PARALLEL CONN.

Size	Document Number	Rev
	JM2	3F
Date:	Monday, January 06, 2003	Sheet 28 of 49

8Mbit (1M Byte),NO PLCC TYPE

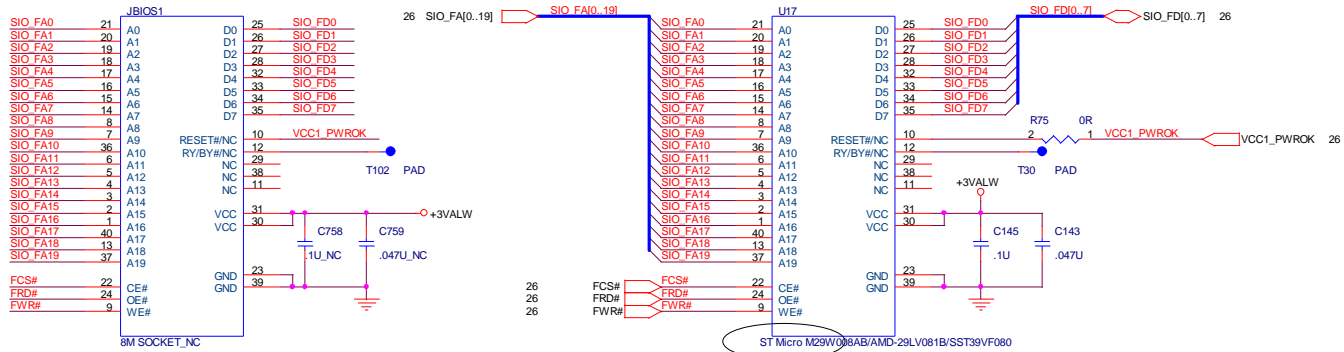

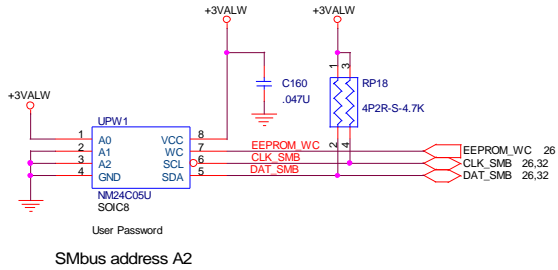

AMD :Pin 10 is RESET# ; Pin12 is RY/BY#
SST :Pin10,12 are NC

- 1.AMD-29LV081B require MAX 500nS Tready for it's hardware reset.And MAX6326_UR29 has >100mS reset timing.So we can tie it's reset# pin to +3VALW directly.
- 2.SIO has internal 20 mS delay of VCC1_PWROK

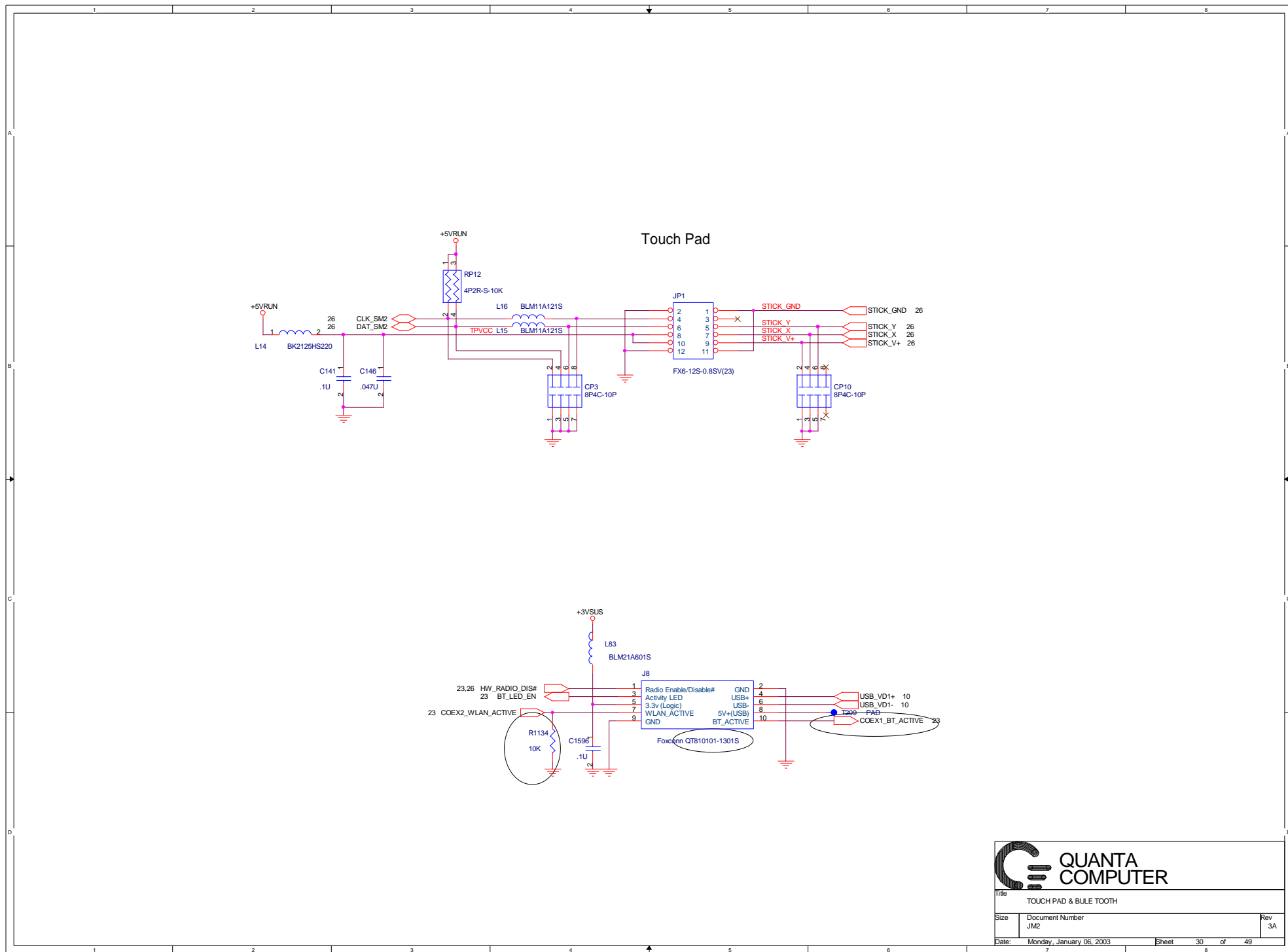

		Rev
		3A
Title	FLASH	
Size	Document Number	Rev
	JM2	
Date:	Monday, January 06, 2003	Sheet 29 of 49



 QUANTA COMPUTER		Title	
		TOUCH PAD & BLUE TOOTH	
Size	Document Number	Rev	
	JM2	3A	
Date:	Monday, January 06, 2003	Sheet	30 of 49

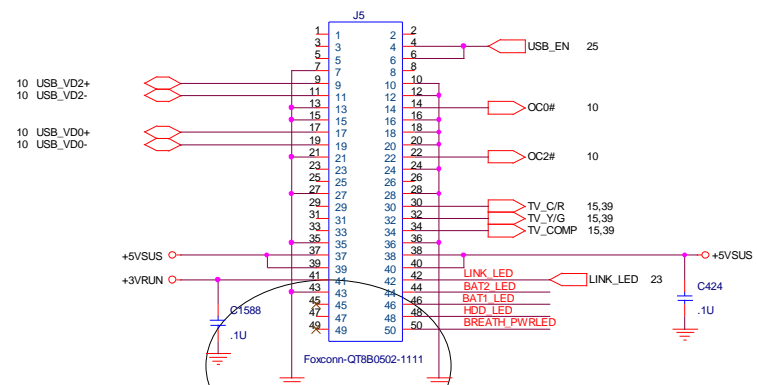
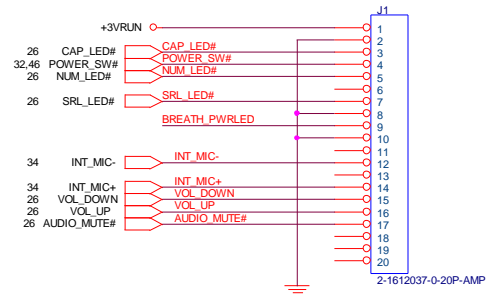
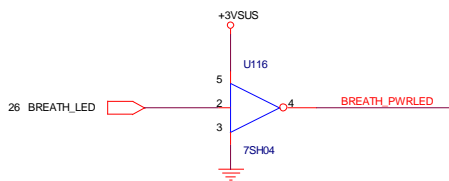
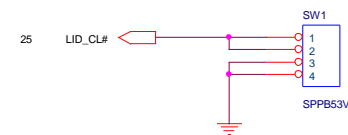
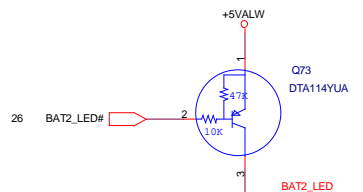
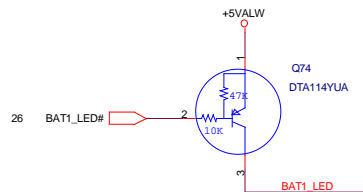
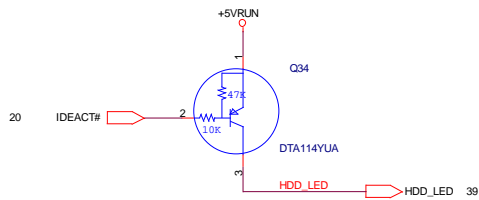

Title SWITCH & LED		
Size JM2	Document Number	Rev 3G
Date: Monday, January 06, 2003	Sheet 31	of 49

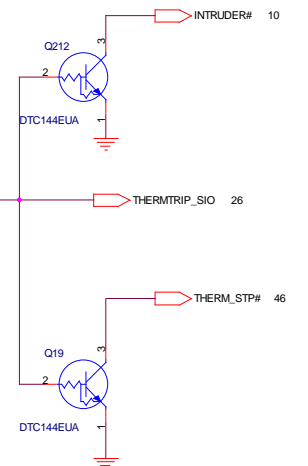
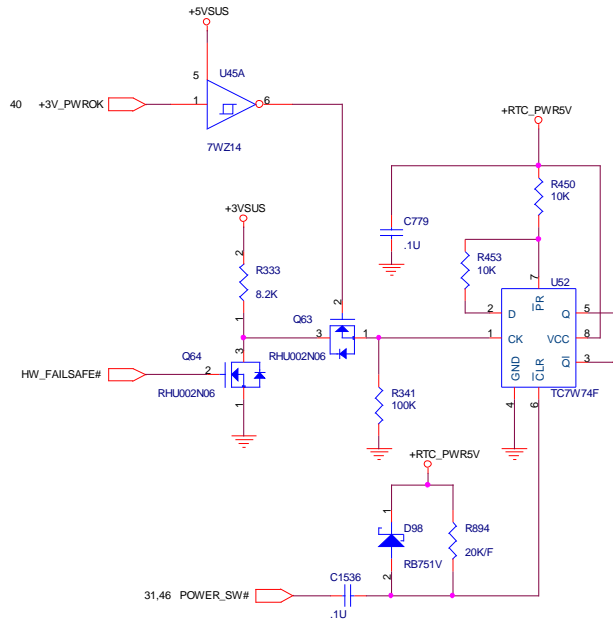
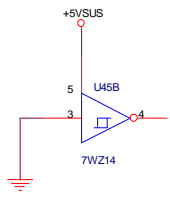
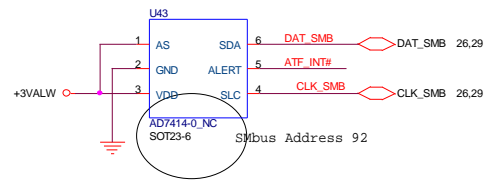
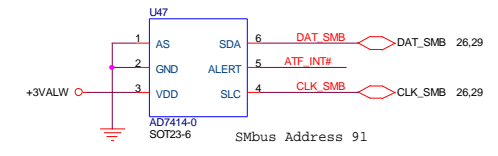
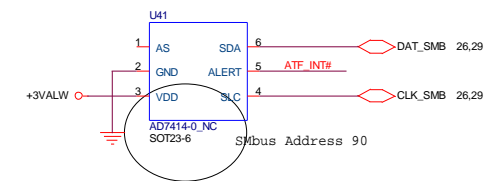
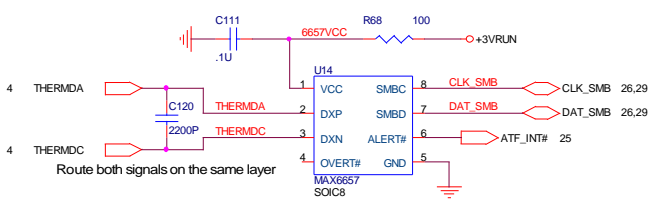
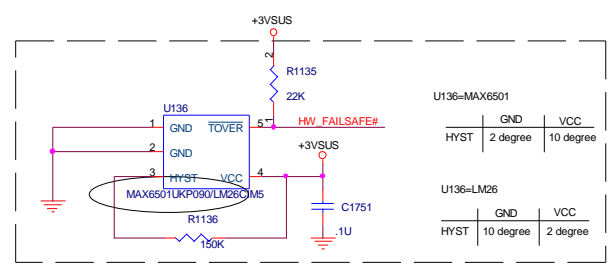
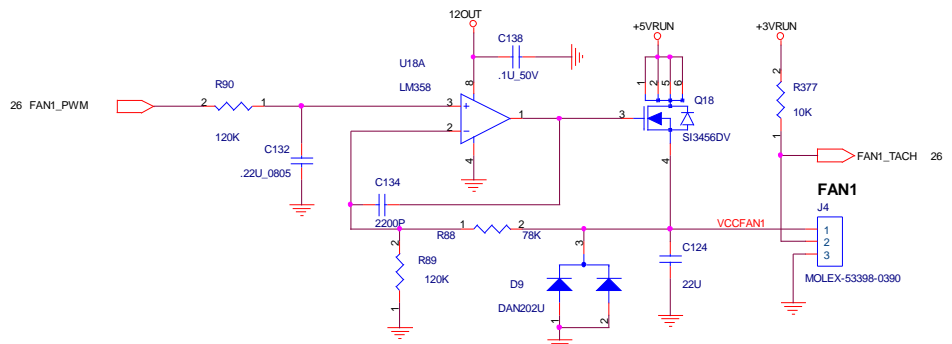

QUANTA COMPUTER

Title: FAN & THERMAL

Size: Document Number JM2 Rev: 3A

Date: Monday, January 06, 2003 Sheet: 32 of 49

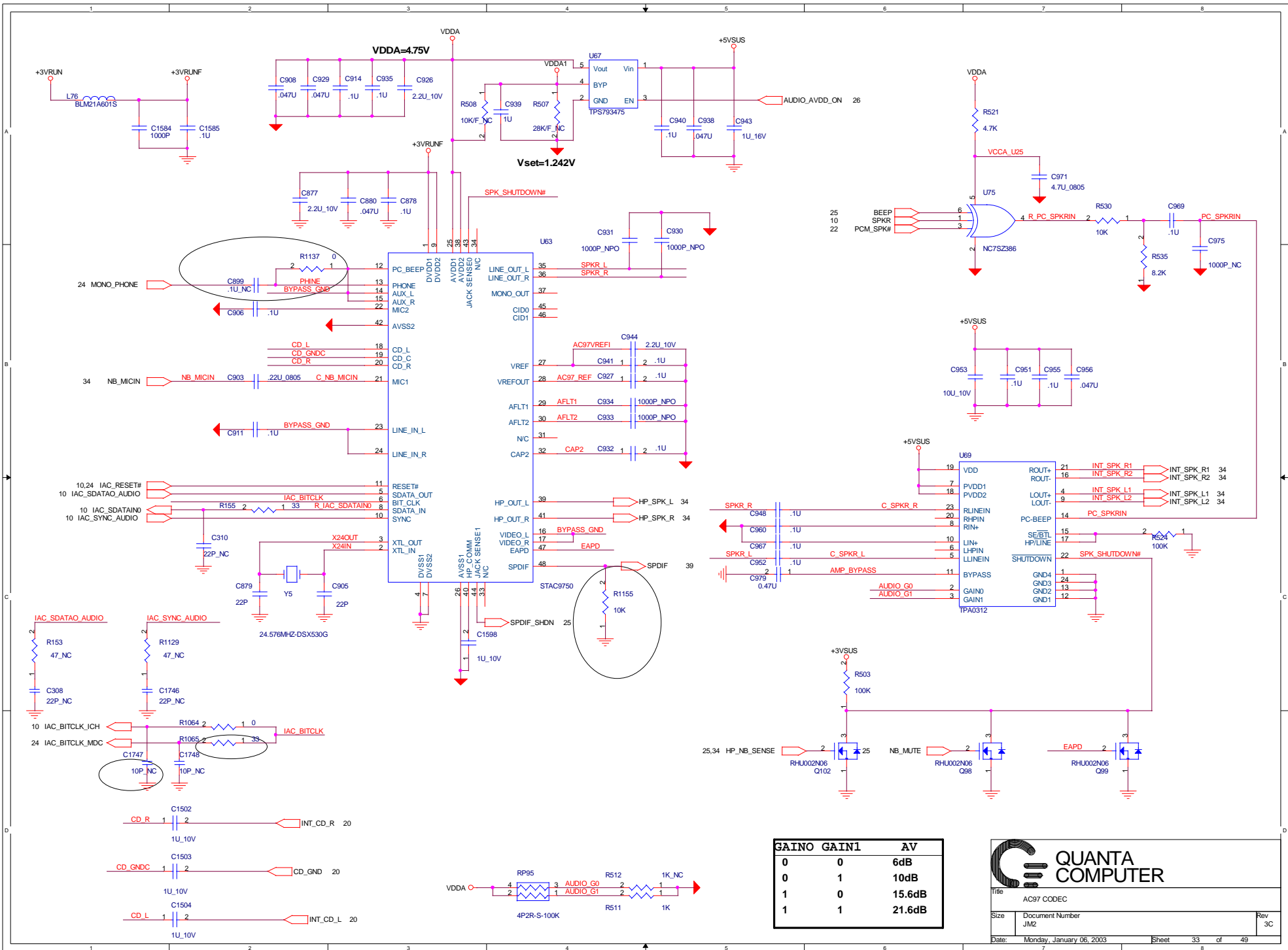

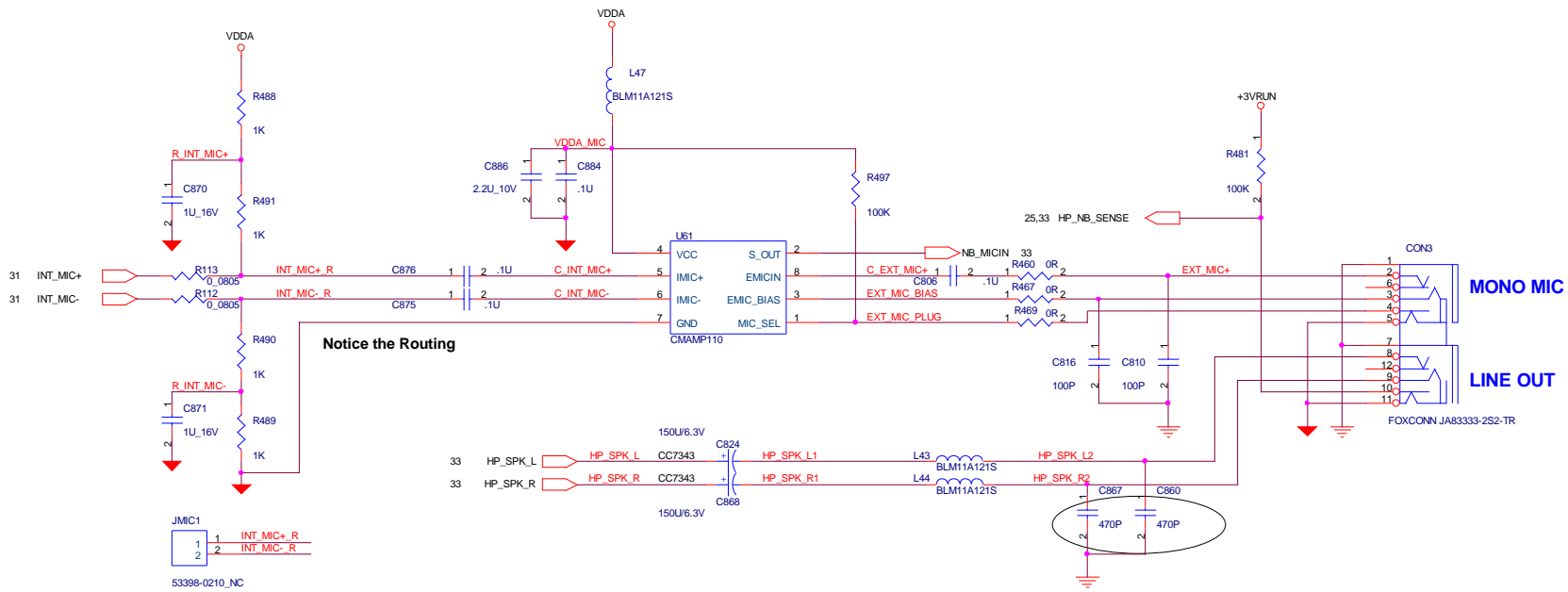

Notice the Routing

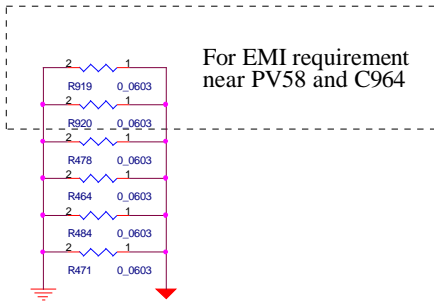
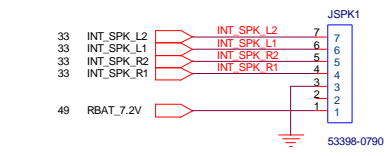
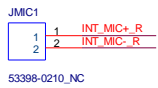

QUANTA COMPUTER

Title: AUDIO CONN

Size: Document Number JM2 Rev: 3F

Date: Monday, January 06, 2003 Sheet: 34 of 49

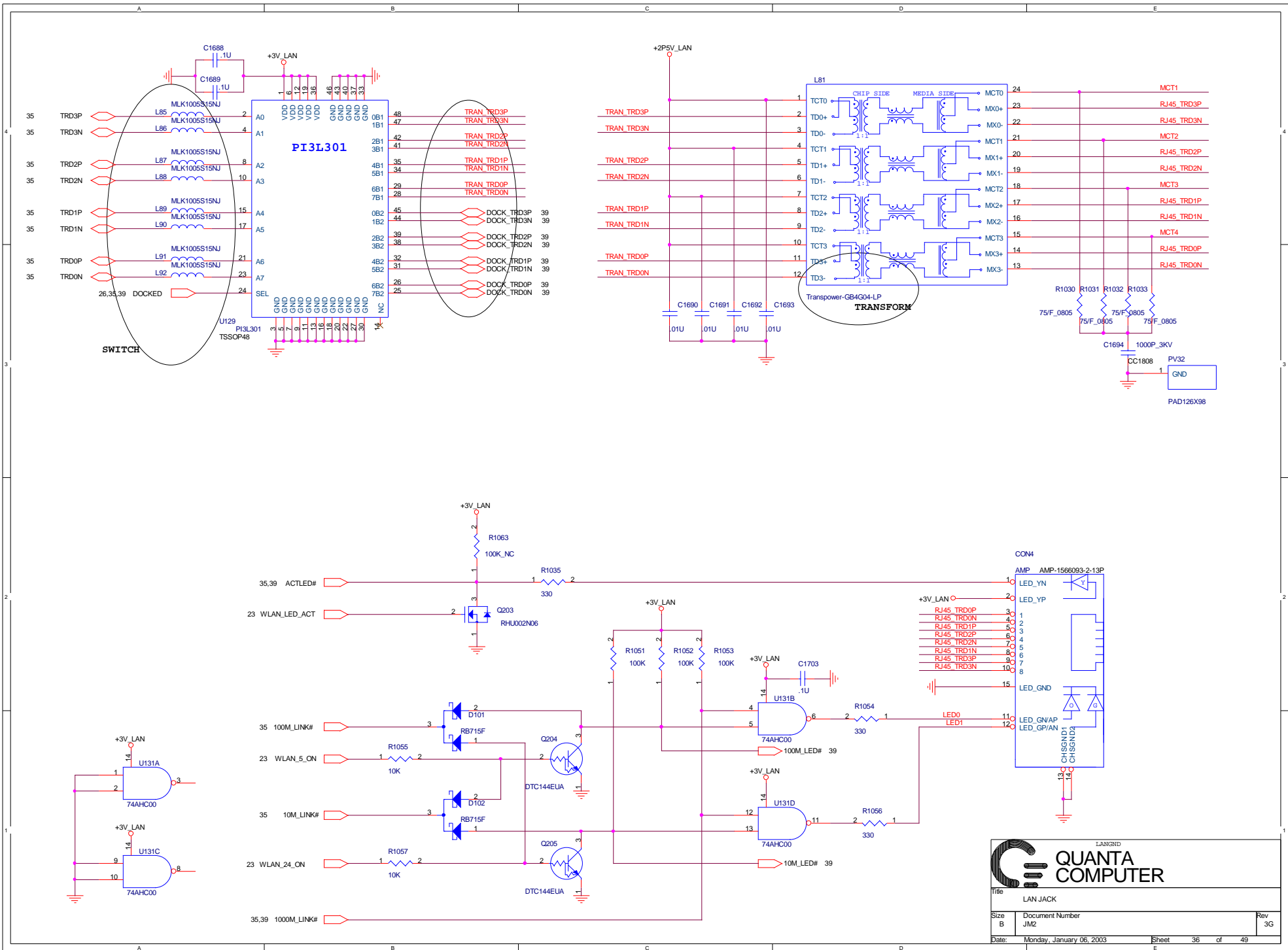

LAN3ND
QUANTA COMPUTER

Title: LAN JACK

Size: B	Document Number: JM2	Rev: 3G
Date: Monday, January 06, 2003	Sheet: 36 of 49	

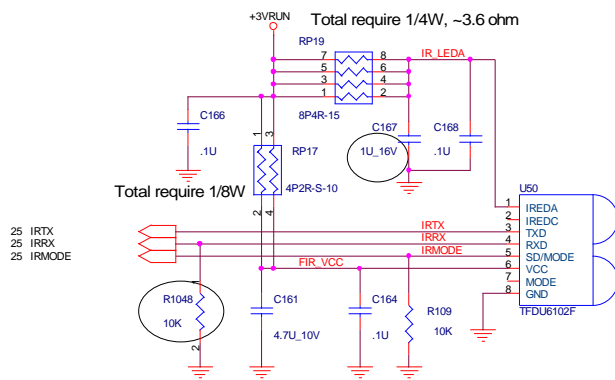

 QUANTA COMPUTER		Title	
		FIR	
Size	Document Number	Rev	
	JM2	3G	
Date:	Monday, January 06, 2003	Sheet	37 of 49
	7		8

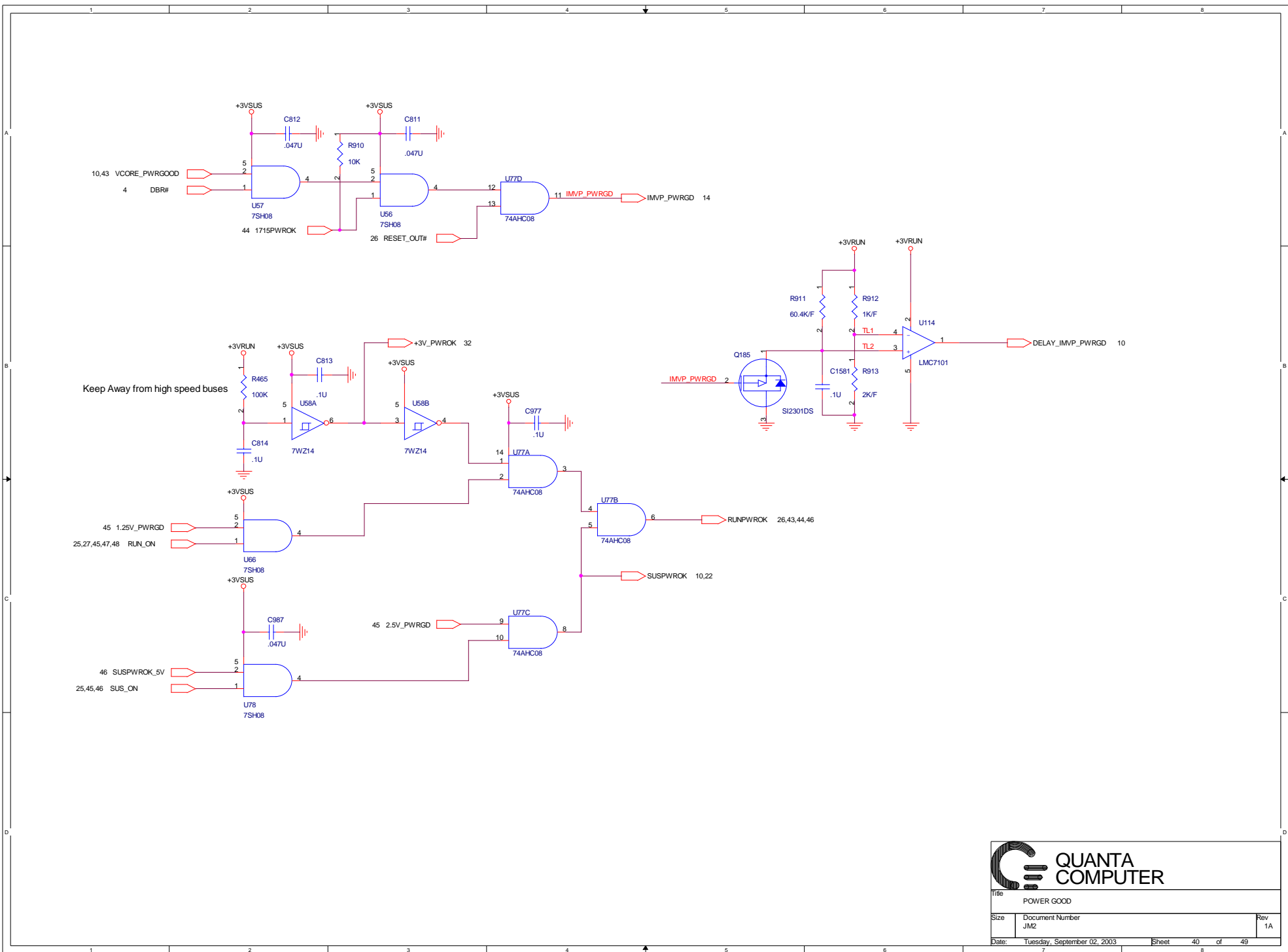

 QUANTA COMPUTER		Title	
		POWER GOOD	
Size	Document Number	Rev	
	JM2	1A	
Date:	Tuesday, September 02, 2003	Sheet	40 of 49

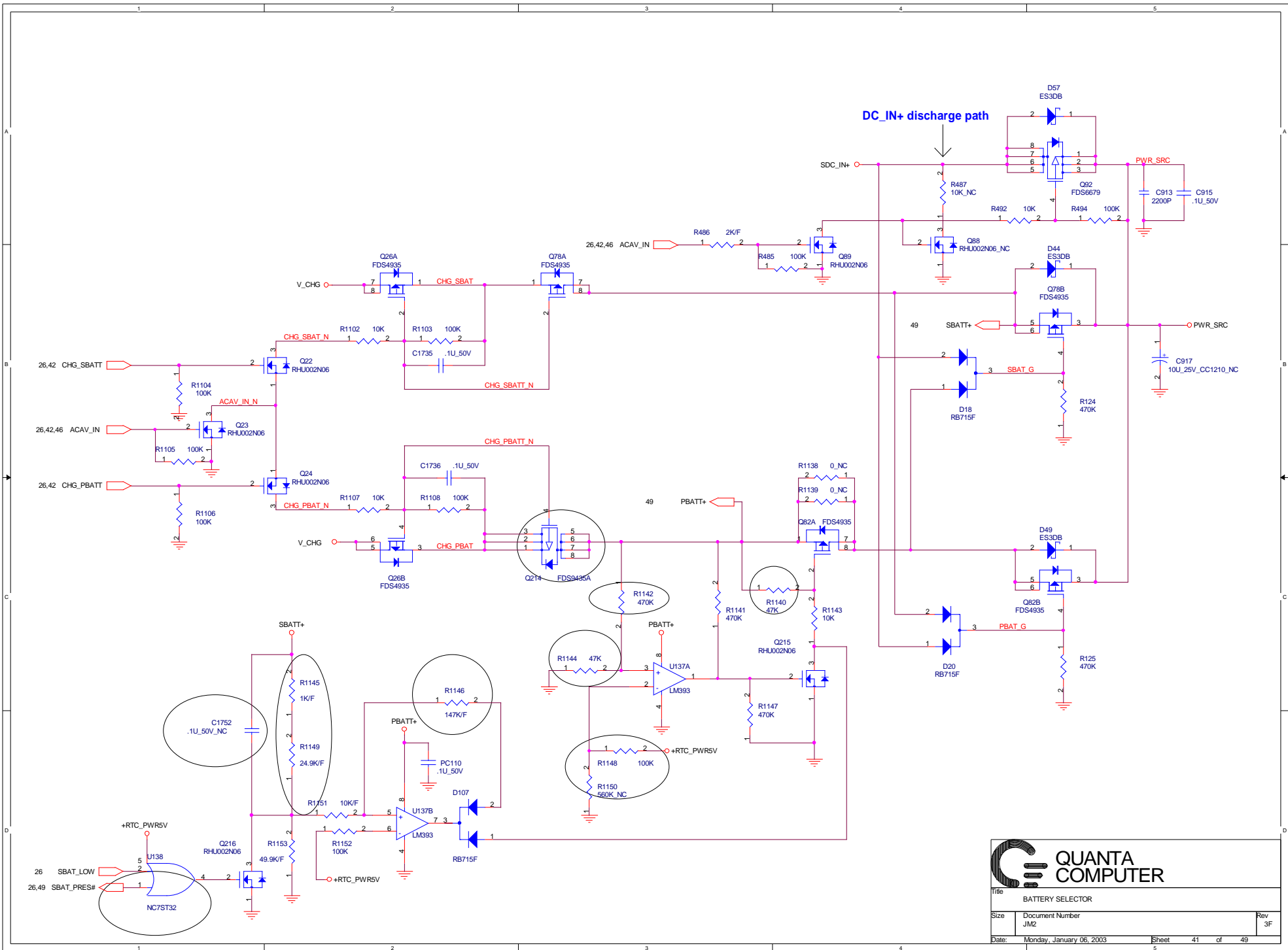

QUANTA COMPUTER

Title: BATTERY SELECTOR

Size	Document Number	Rev
	JM2	3F
Date:	Monday, January 06, 2003	Sheet 41 of 49

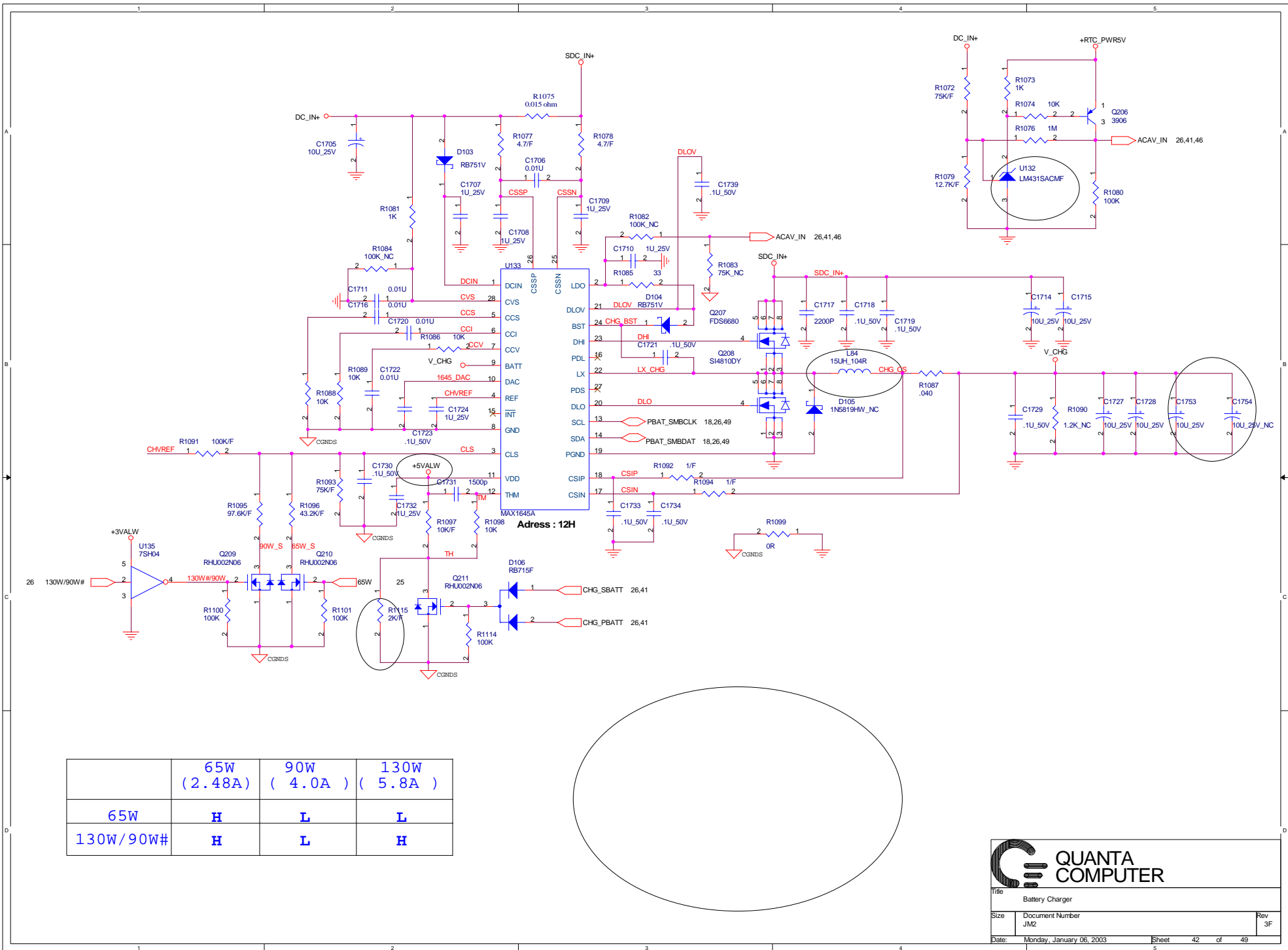

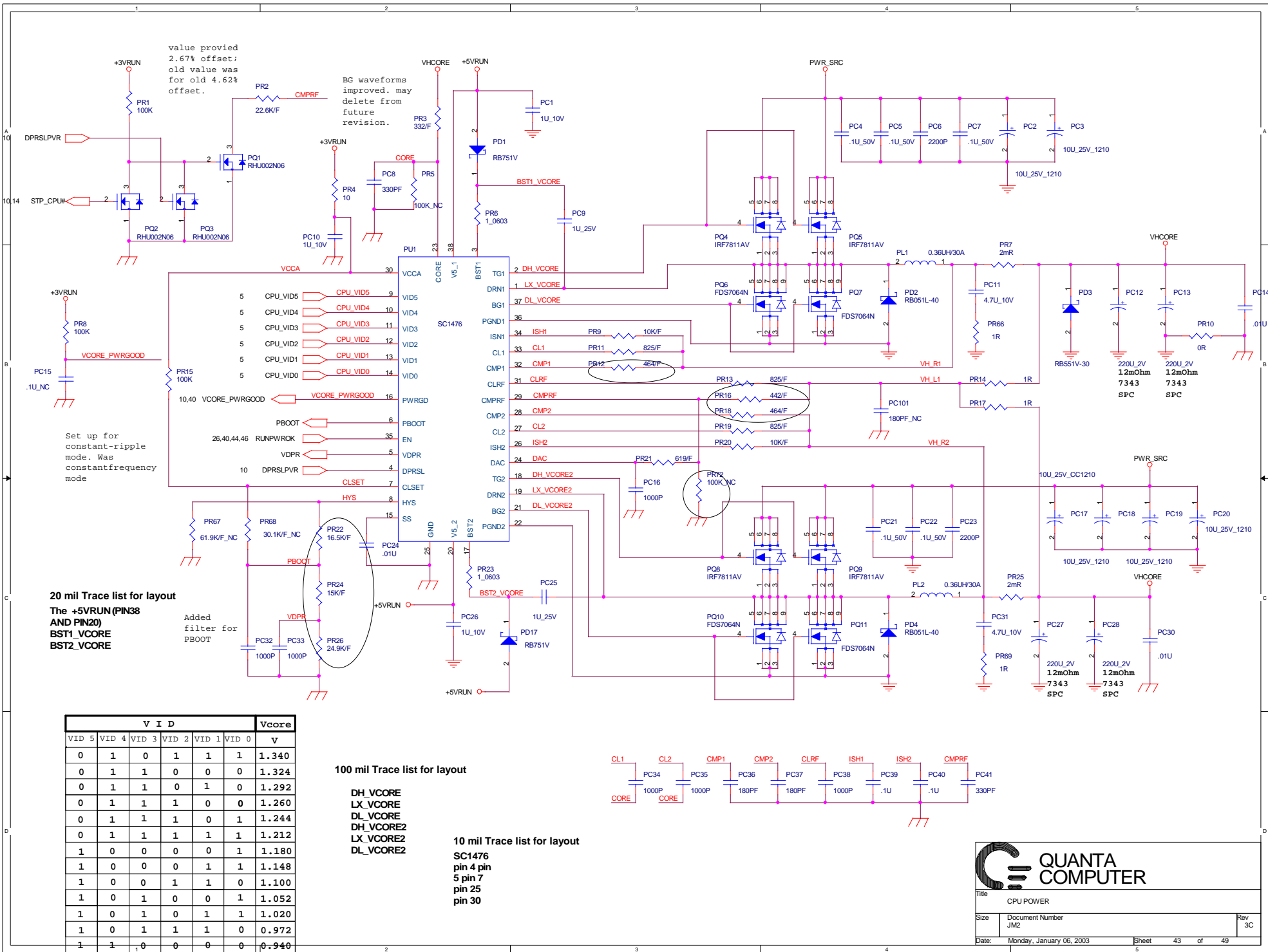

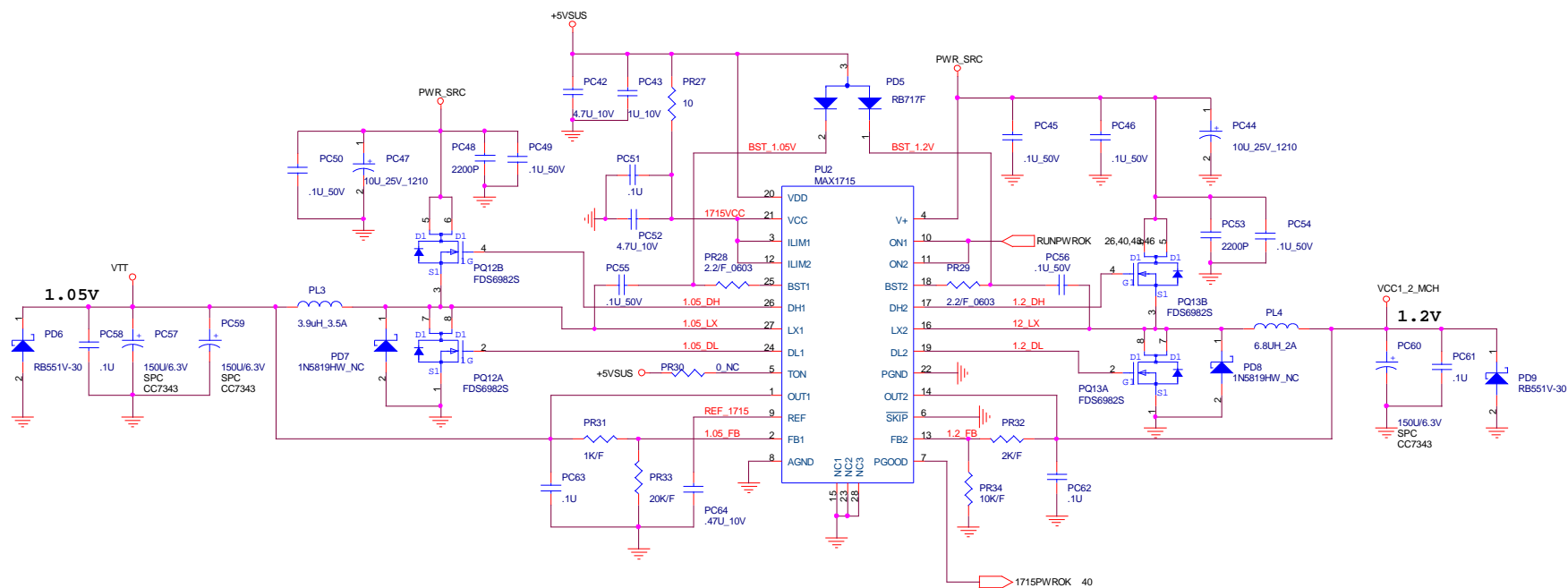

Title		
VTT_1.05V,VCC1_2_MCH		
Size	Document Number	Rev
JM2		1A
Date:	Monday, January 06, 2003	Sheet 44 of 49

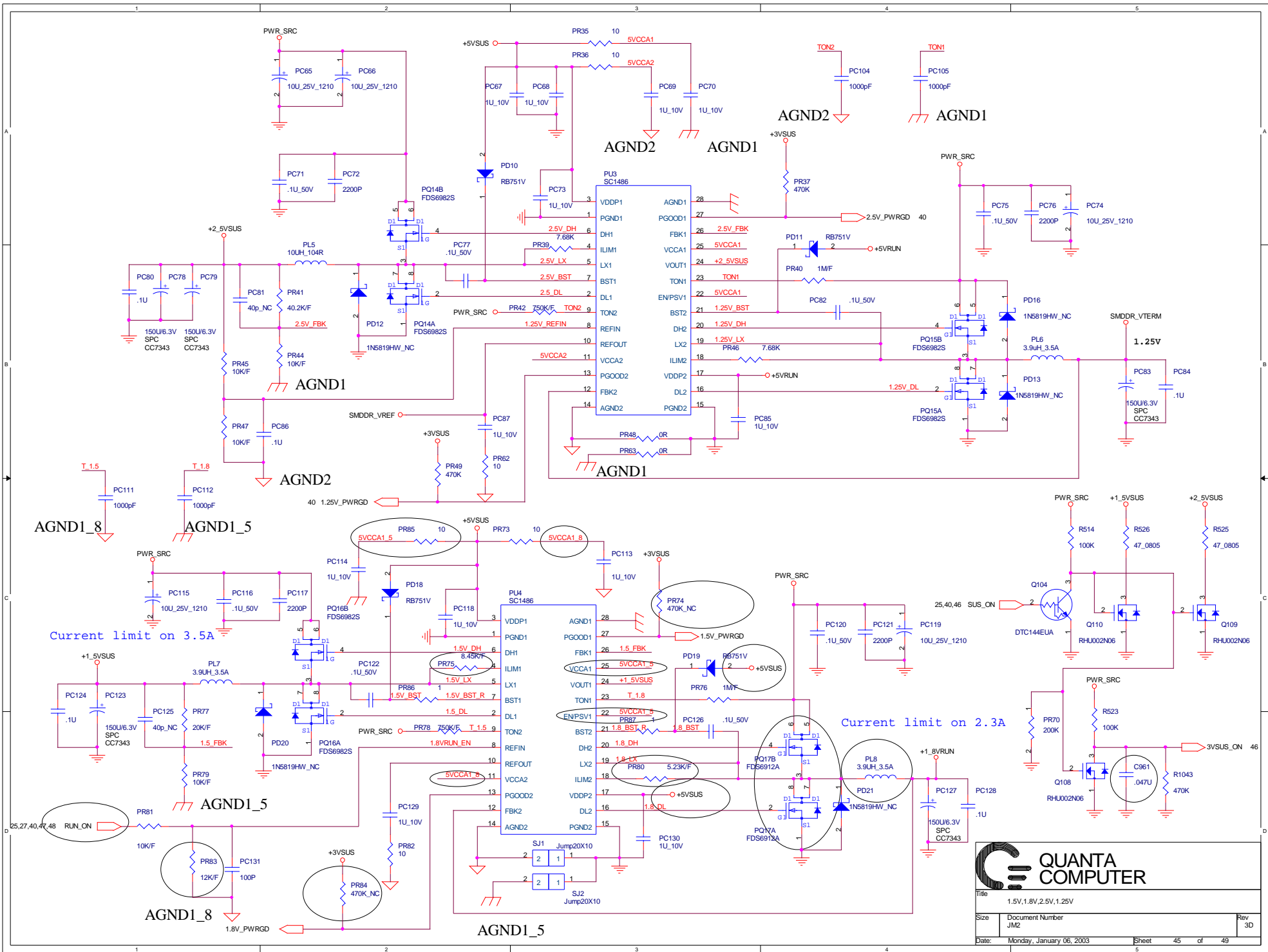

QUANTA COMPUTER

Title: 1.5V, 1.8V, 2.5V, 1.25V

Size: Document Number JM2

Date: Monday, January 06, 2003

Sheet: 45 of 49

Rev: 3D

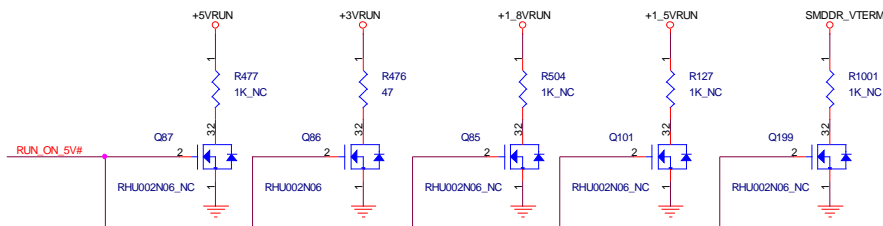
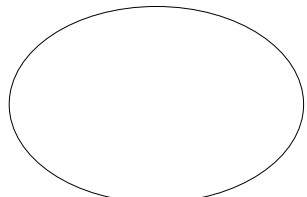
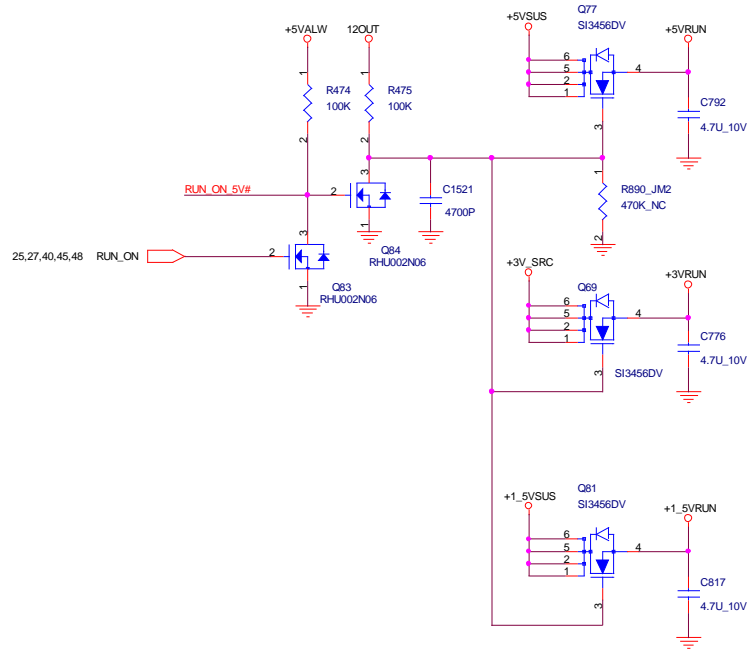

Reserve discharge path

 QUANTA COMPUTER		
Title: RUN POWER SW		
Size: JM2	Document Number:	Rev: 3C
Date: Monday, January 06, 2003	Sheet: 47	of 49

POW_SW	M7D/M9 CSP 16 32
0	1.5V
1	1.25V

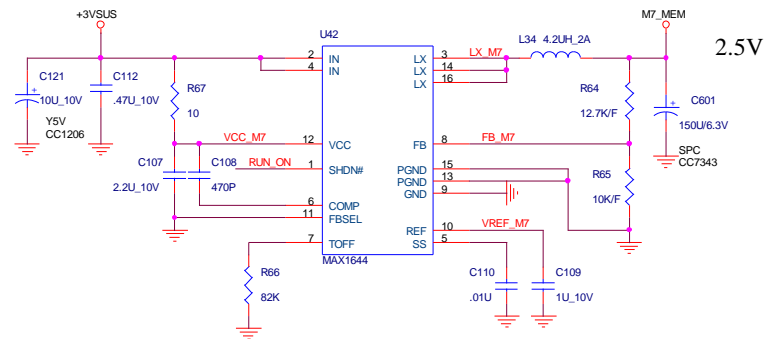
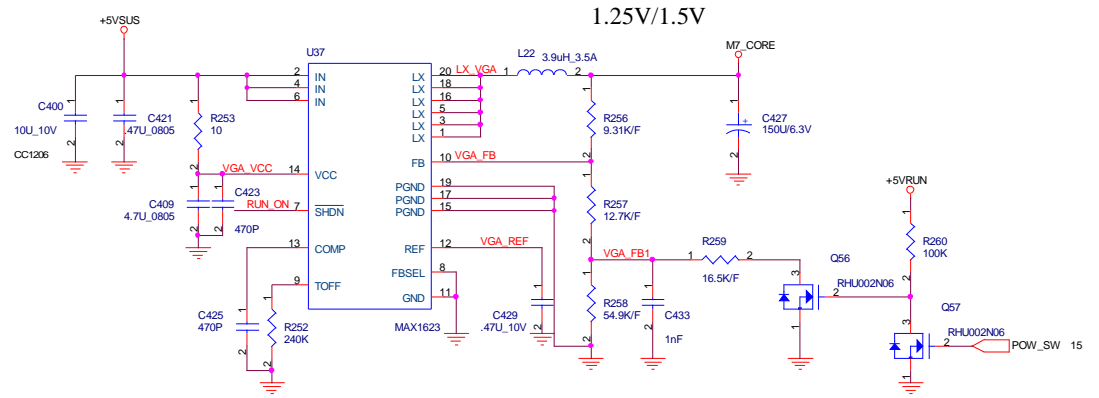
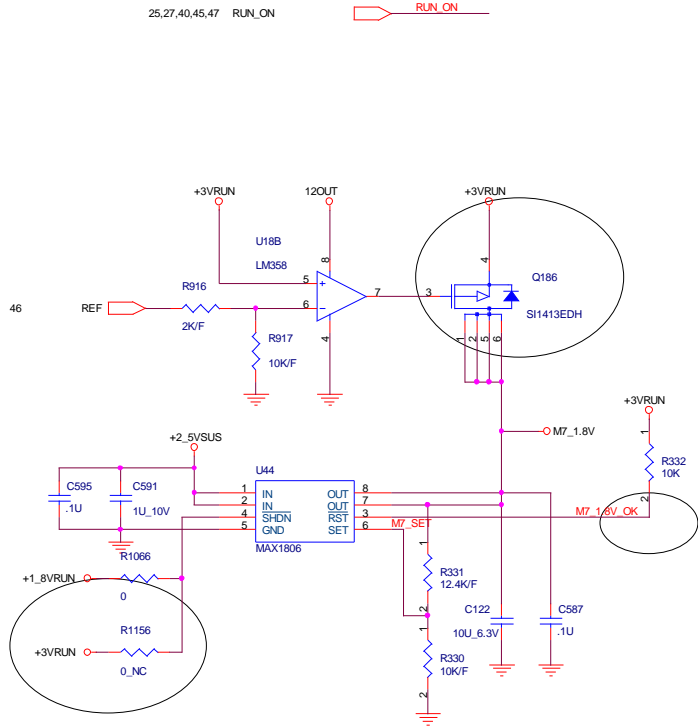

Title		VGA DC/DC
Size	Document Number	Rev
	JM2	3F
Date:	Friday, January 17, 2003	Sheet 48 of 49

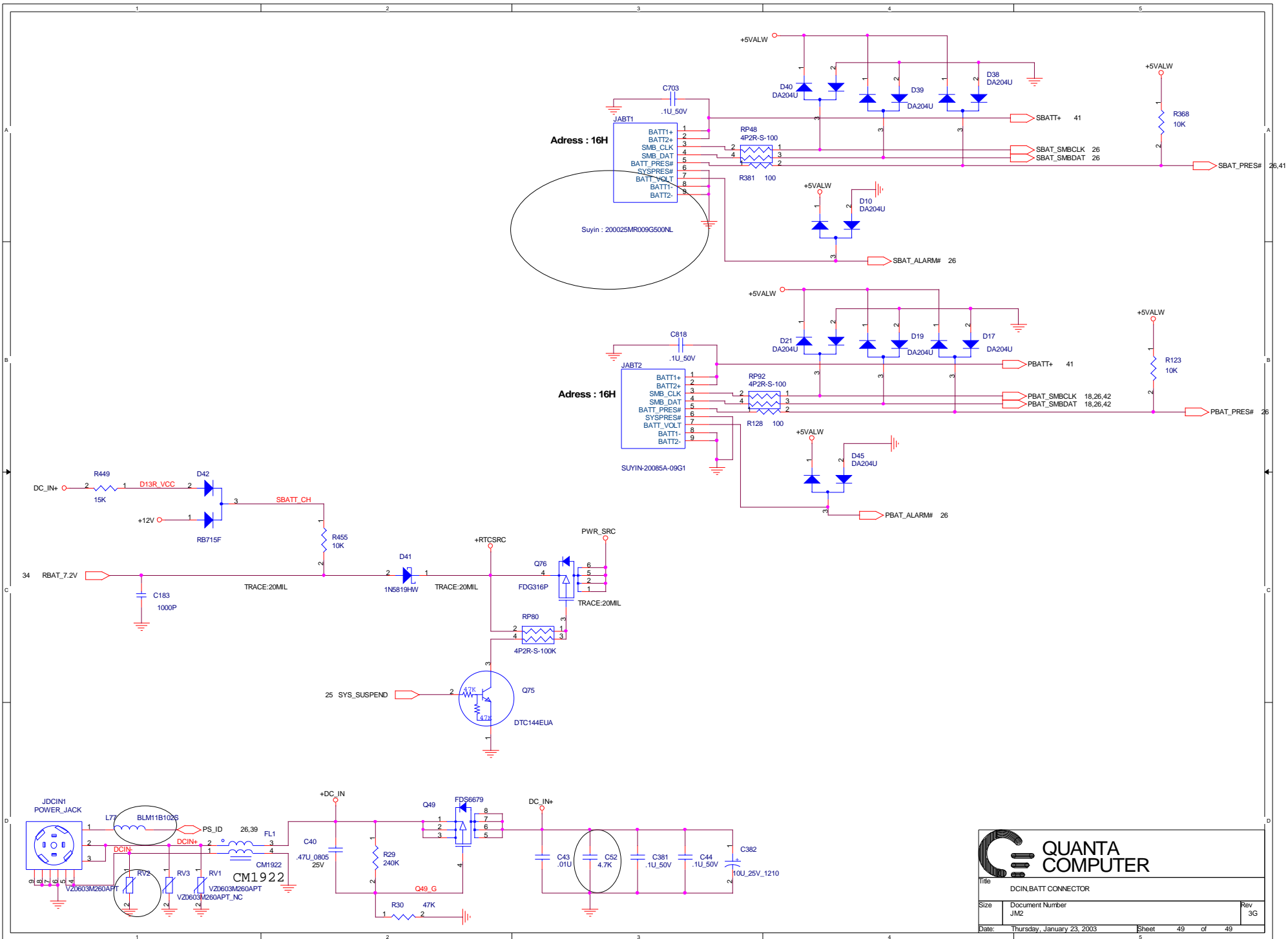

QUANTA COMPUTER

Title: DCIN.BATT CONNECTOR

Size: Document Number JM2 Rev: 3G

Date: Thursday, January 23, 2003 Sheet: 49 of 49