

DAYTONA

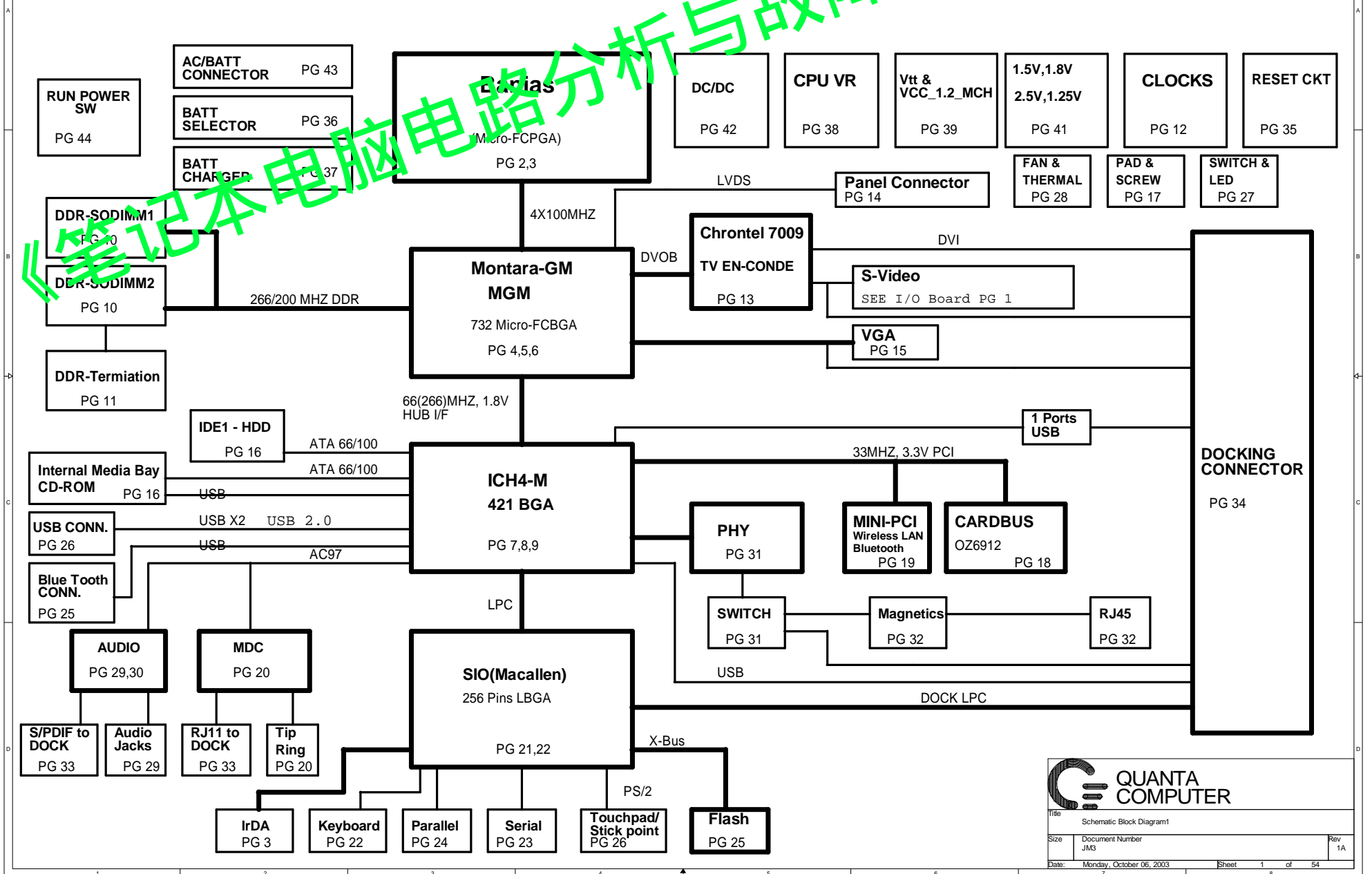

QUANTA COMPUTER

Title	Schematic Block Diagram1		Rev	1A
Size	Document Number	JMS		
Date:	Monday, October 06, 2003	Sheet	1	of 54

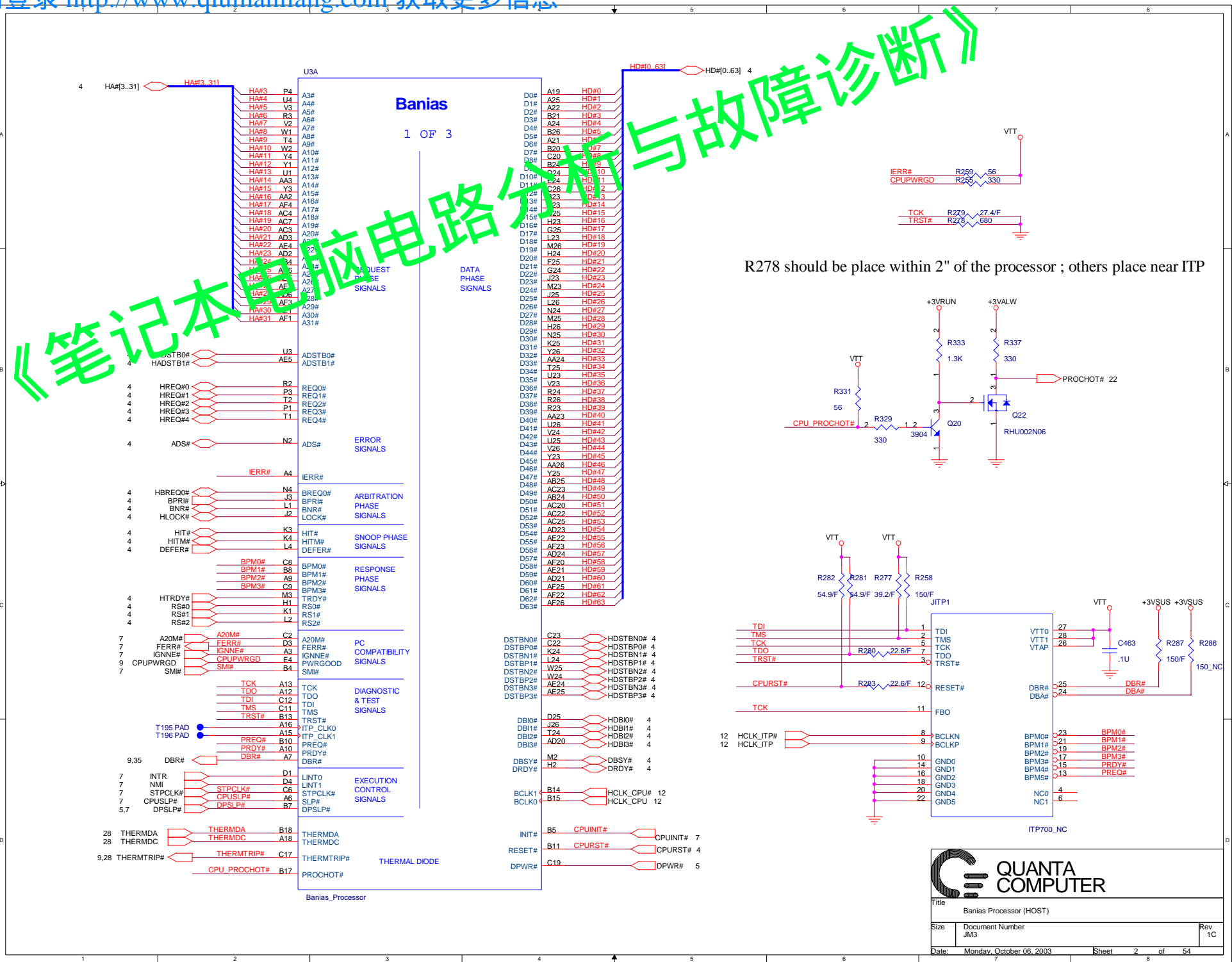

These 4 Resistors need to place with 0.5" of CPU.
Comp0,2 trace need to be $z=27.4\ \Omega$,
comp1,3 traces need to be $z=55\ \Omega$.

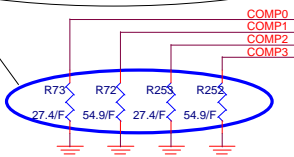

A0 CPU install R256 R254

A1 CPU not install R256 R254

1.5V option is not used. It is ok to leave in there.

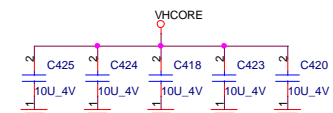
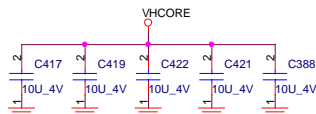
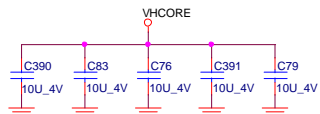
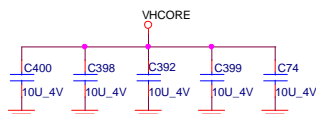
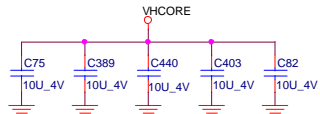
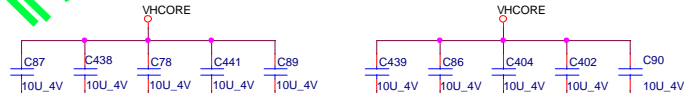

10U/25V Total caps
35 PCS=350UF

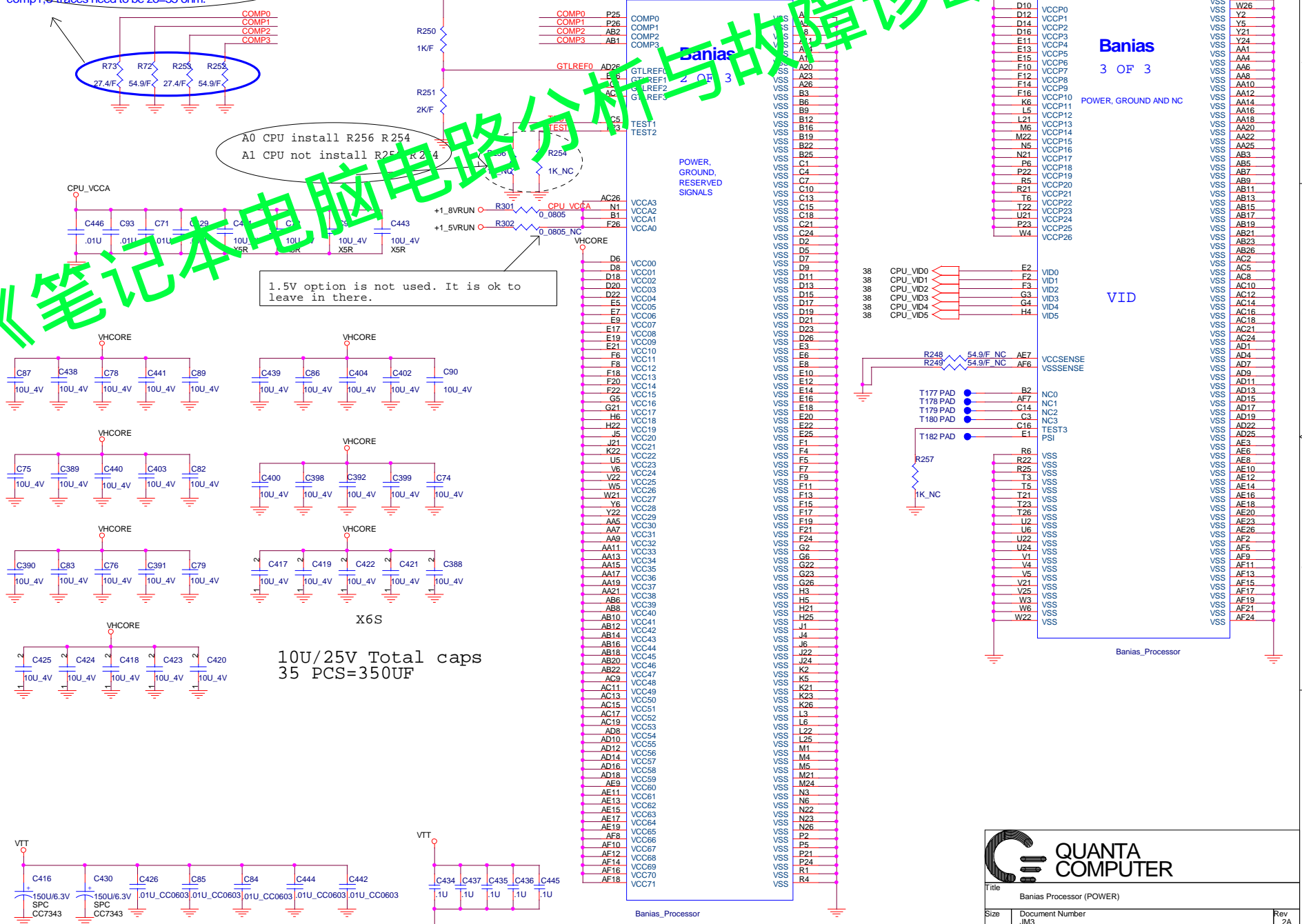
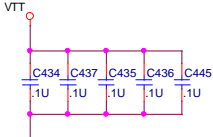
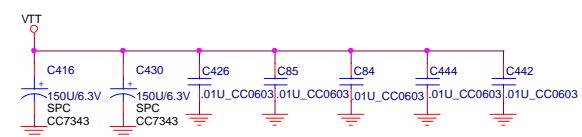

《笔记本电脑电路分析与故障诊断》



QUANTA COMPUTER

Title: Banias Processor (POWER)

Size	Document Number	Rev
	JM3	2A

Date: Monday, October 06, 2003 Sheet 3 of 54

《笔记本电脑电路分析与故障诊断》

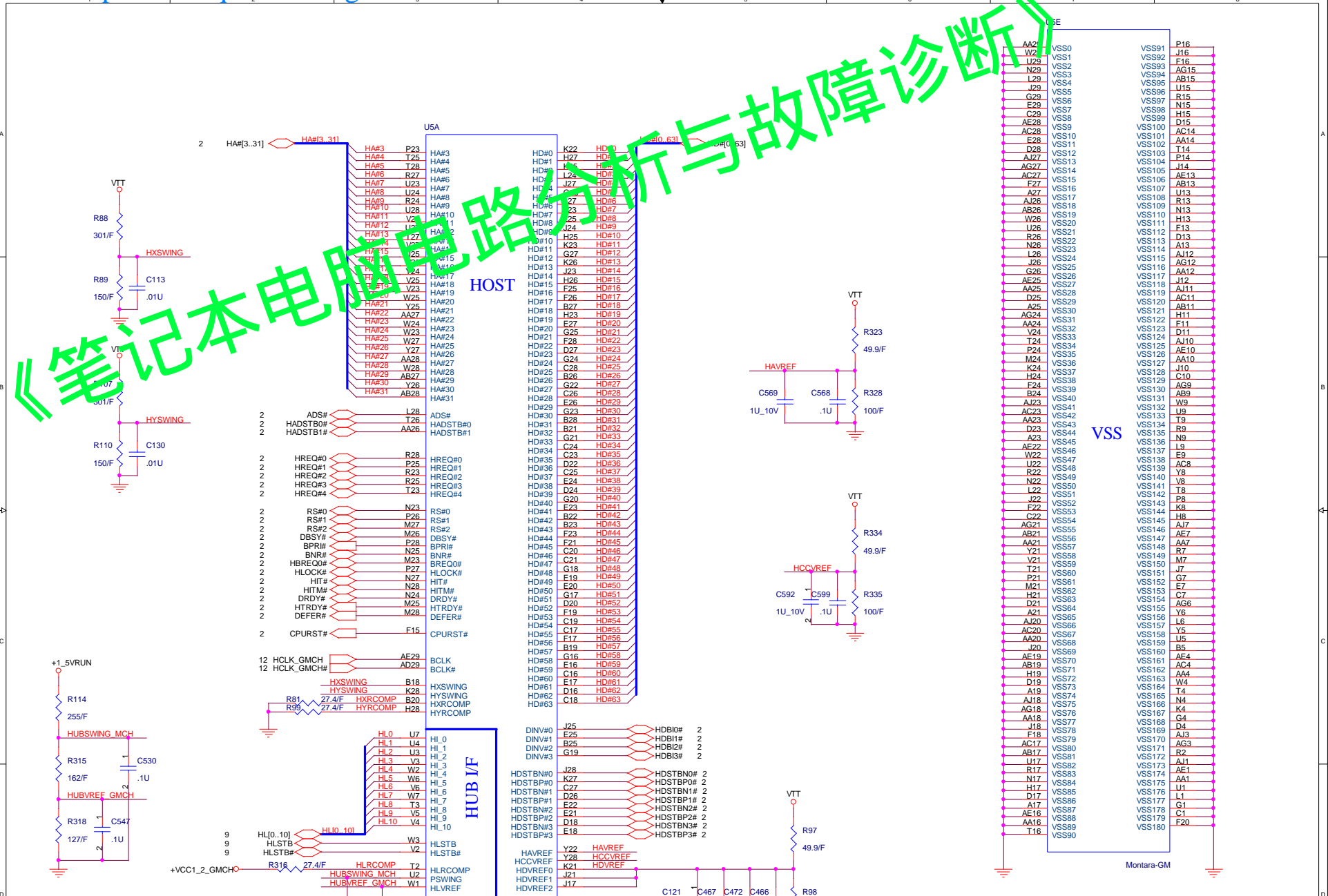

QUANTA COMPUTER

Title: Montara - GM (HOST)

Size:	Document Number	Rev
	JM3	1A

Date: Monday, October 06, 2003 | Sheet 4 of 54

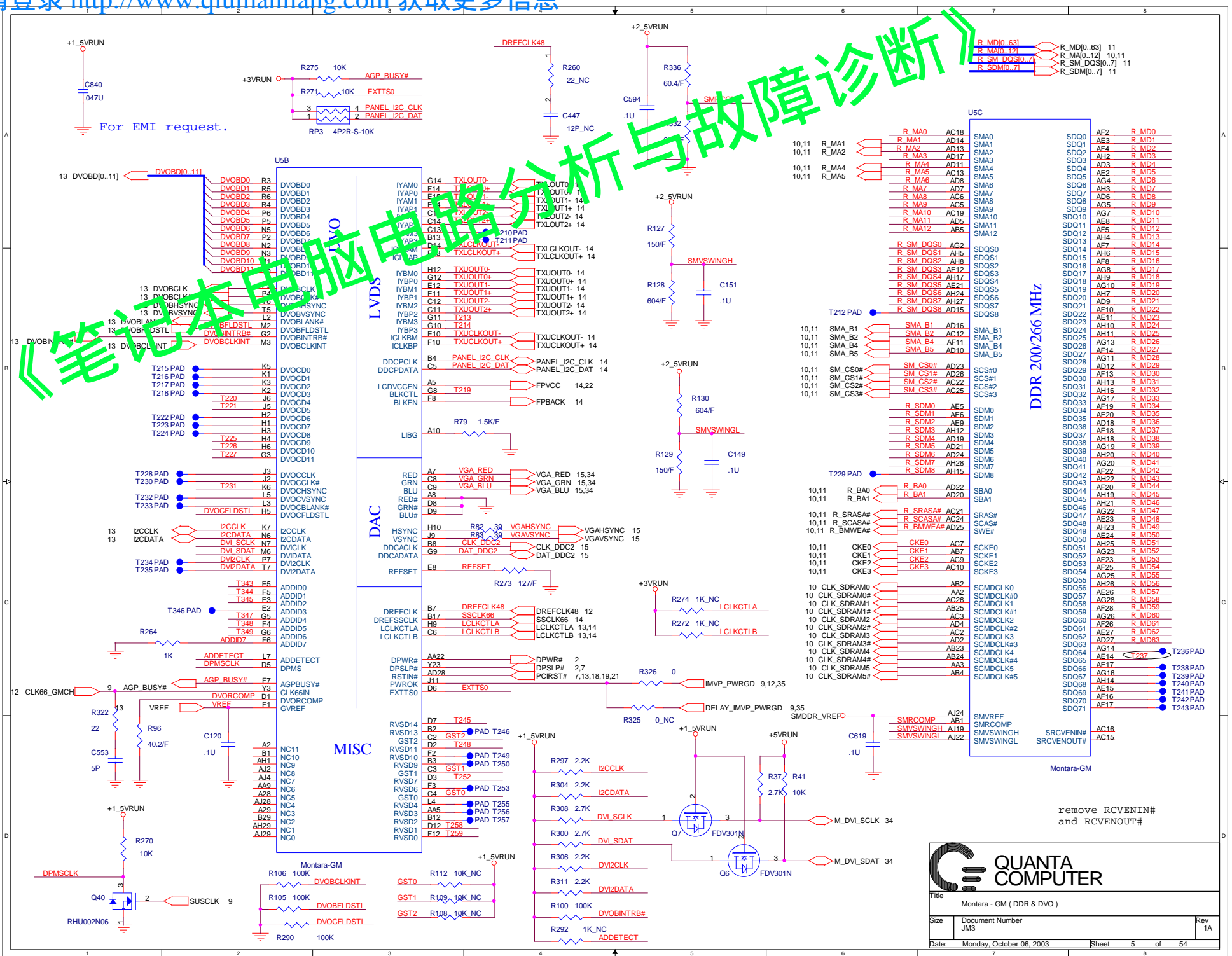

Title: Montara - GM (DDR & DVO)		
Size:	Document Number: JM3	Rev: 1A
Date:	Monday, October 06, 2003	Sheet: 5 of 54

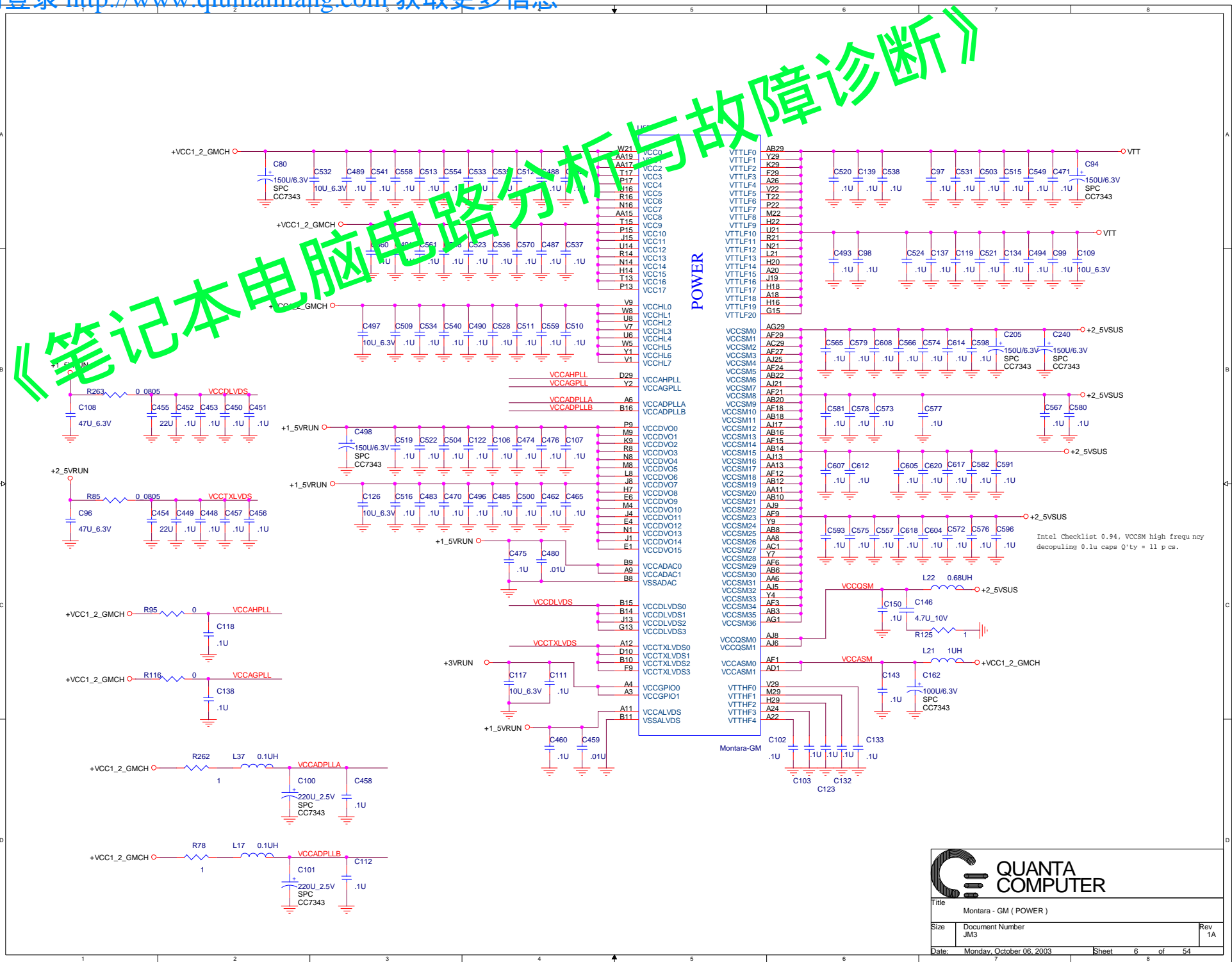

QUANTA COMPUTER

Title: Montara - GM (POWER)

Size	Document Number	Rev
	JM3	1A

Date: Monday, October 06, 2003 Sheet 6 of 54

《笔记本电脑电路分析与故障诊断》

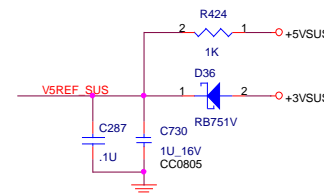
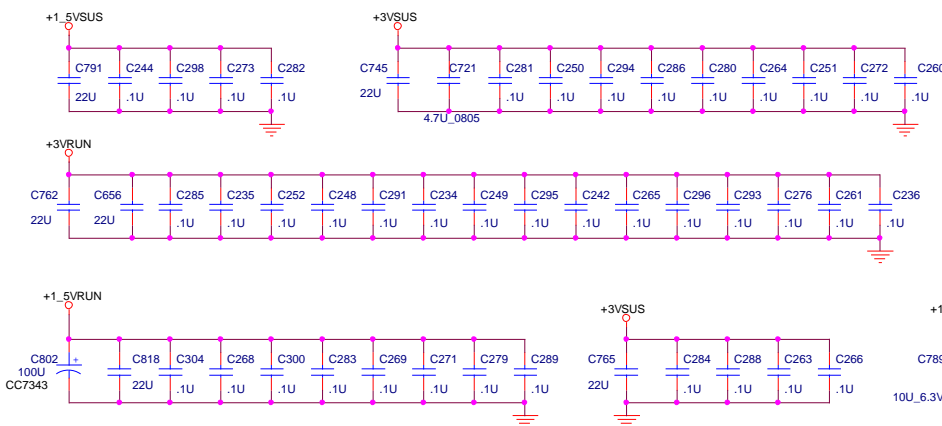
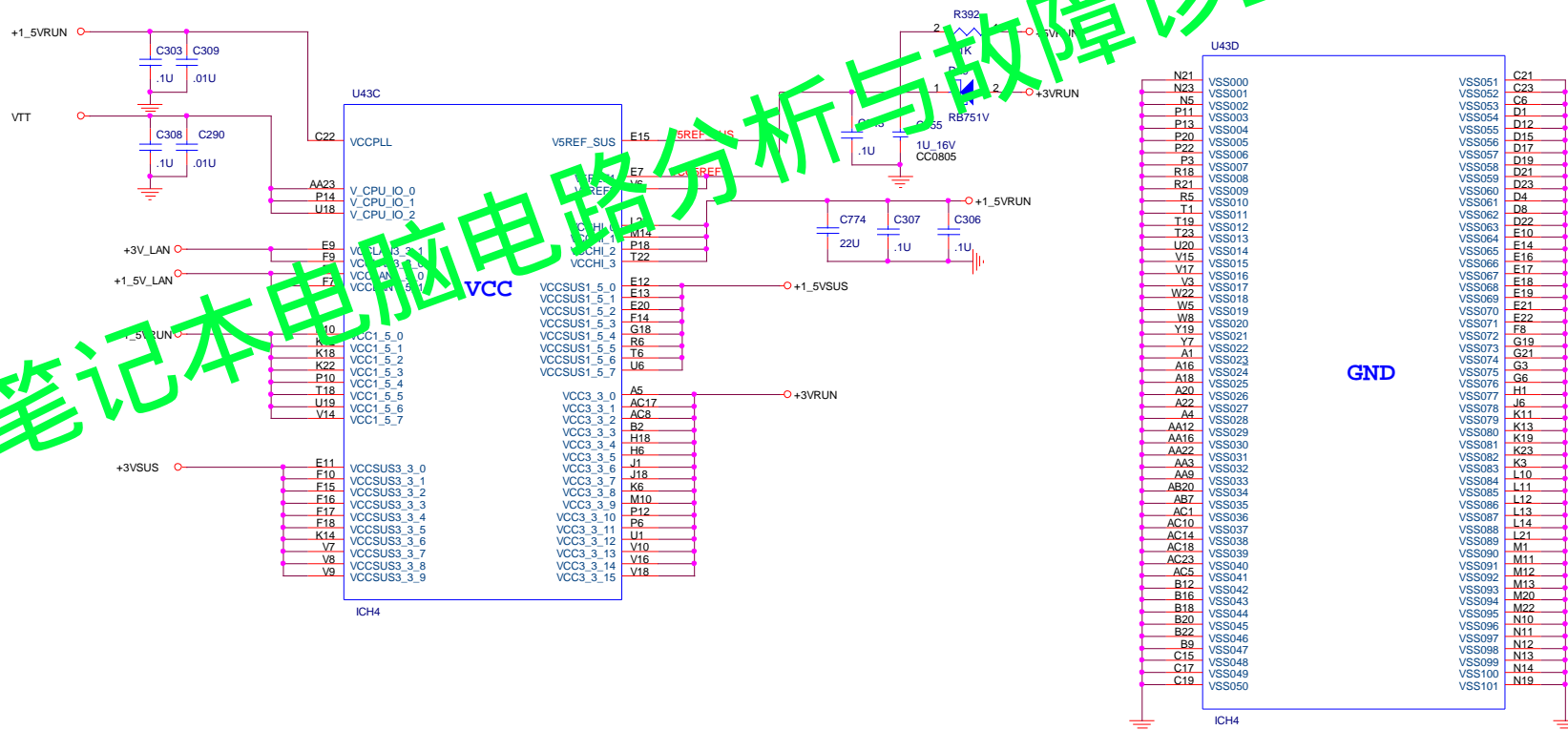

Title: ICH4-M (POWER&GND)		
Size: JM3	Document Number:	Rev: 1A
Date: Monday, October 06, 2003	Sheet: 8	of 54

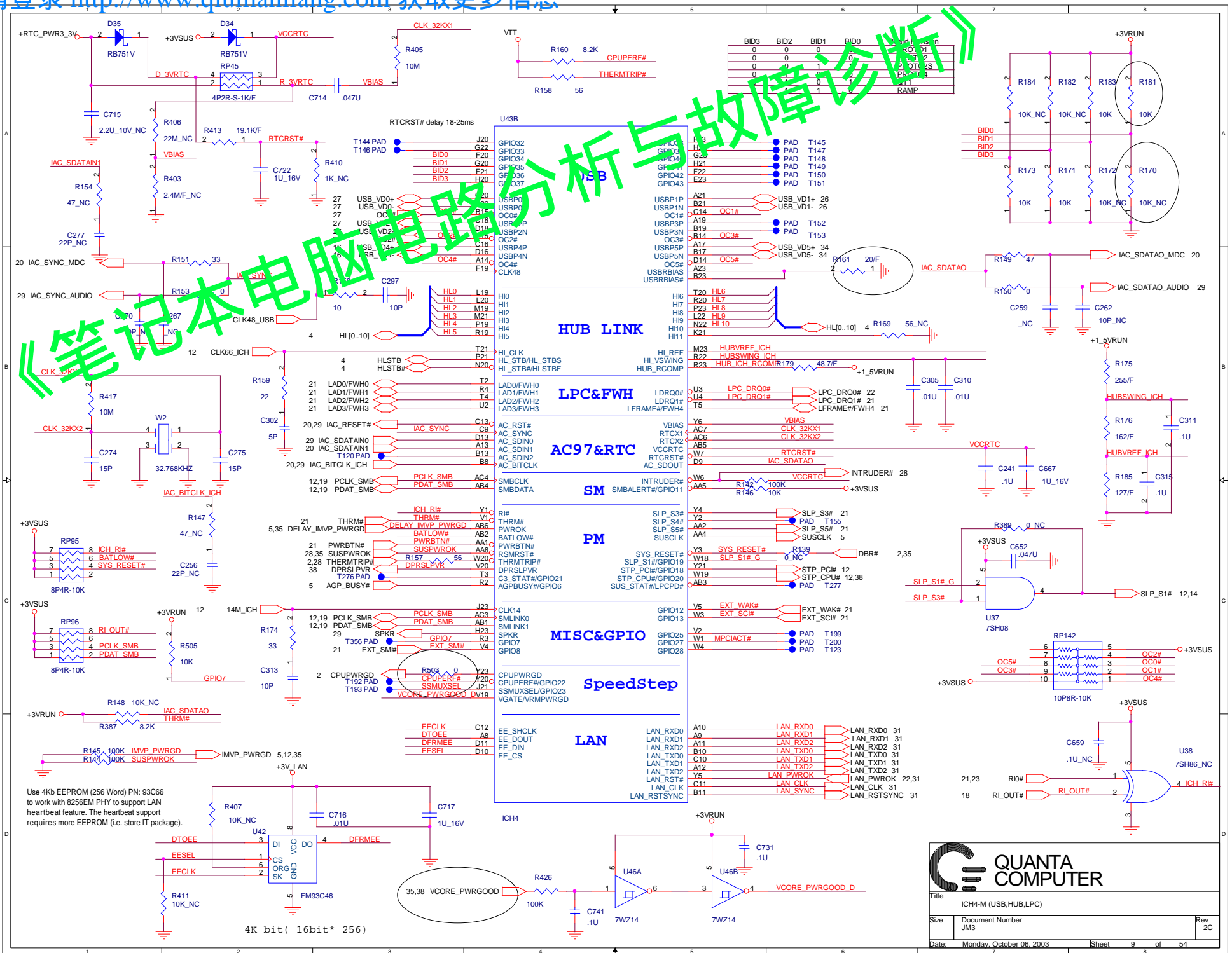

QUANTA COMPUTER

Title: ICH4-M (USB,HUB,LPC)

Size: Document Number JM3 Rev 2C

Date: Monday, October 06, 2003 Sheet 9 of 54

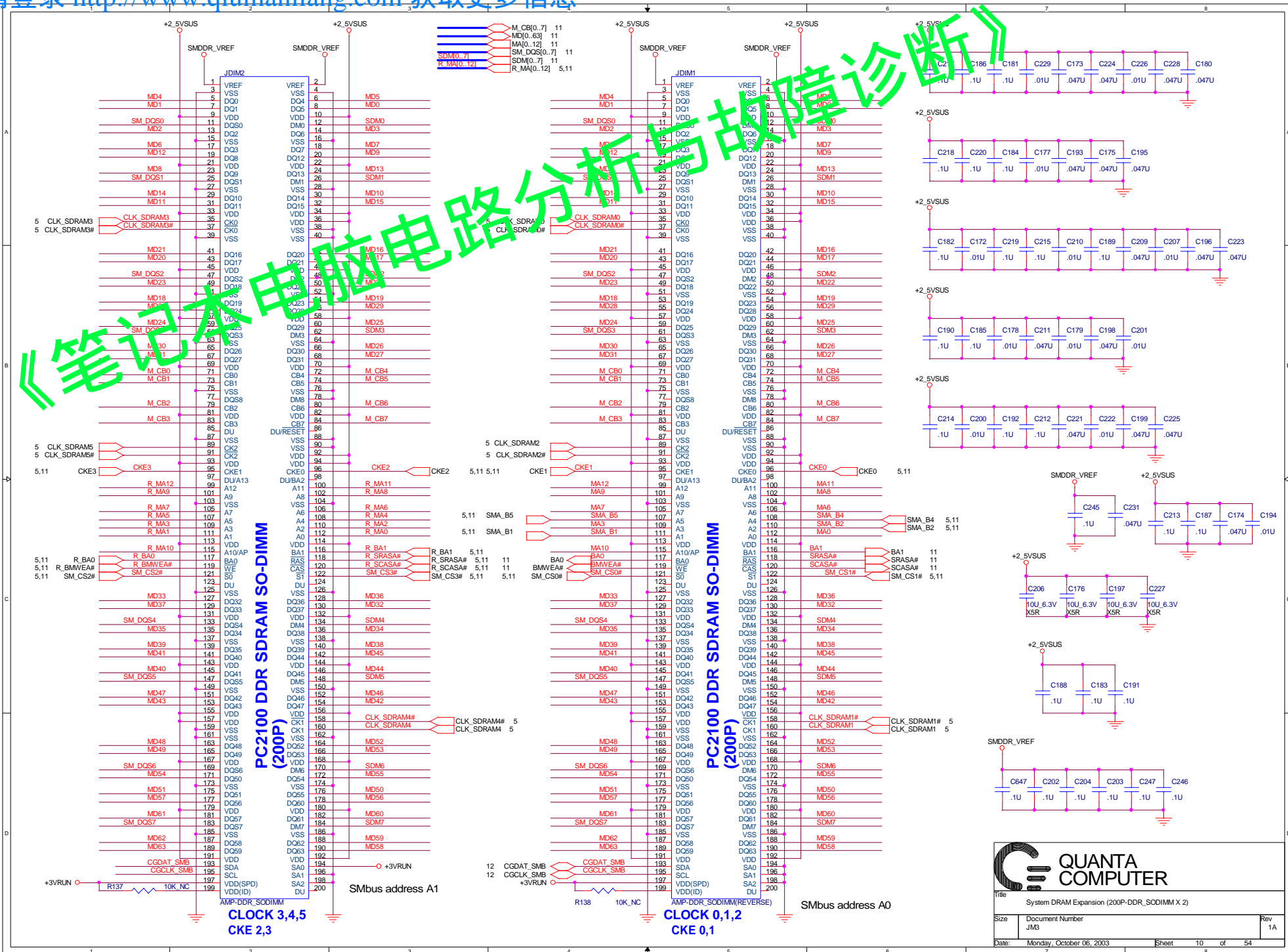



S2	S1	S0	CPU	3V66[0..4]	3V66_5/66IN	
1	0	0	66	66IN	66	Input
1	0	1	100	66IN	66	Input
1	1	0	200	66IN	66	Input
1	1	1	133	66IN	66	Input
0	0	0	66	66	66	Input
0	0	1	100	66	66	Input
0	1	0	200	66	66	Input
0	1	1	133	66	66	Input

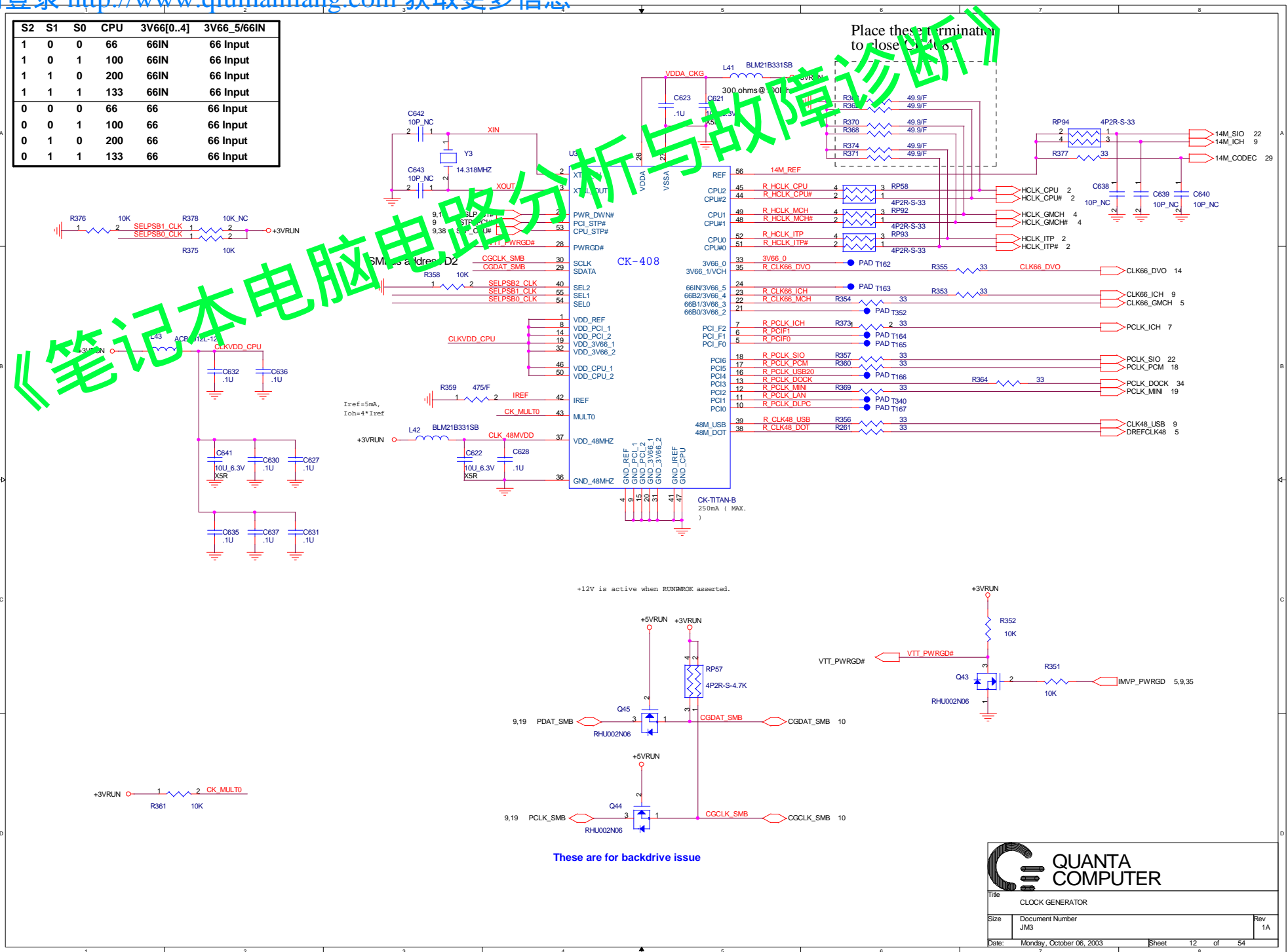

QUANTA COMPUTER

Title: CLOCK GENERATOR

Size: Document Number JMS Rev: 1A

Date: Monday, October 06, 2003 Sheet: 12 of 54

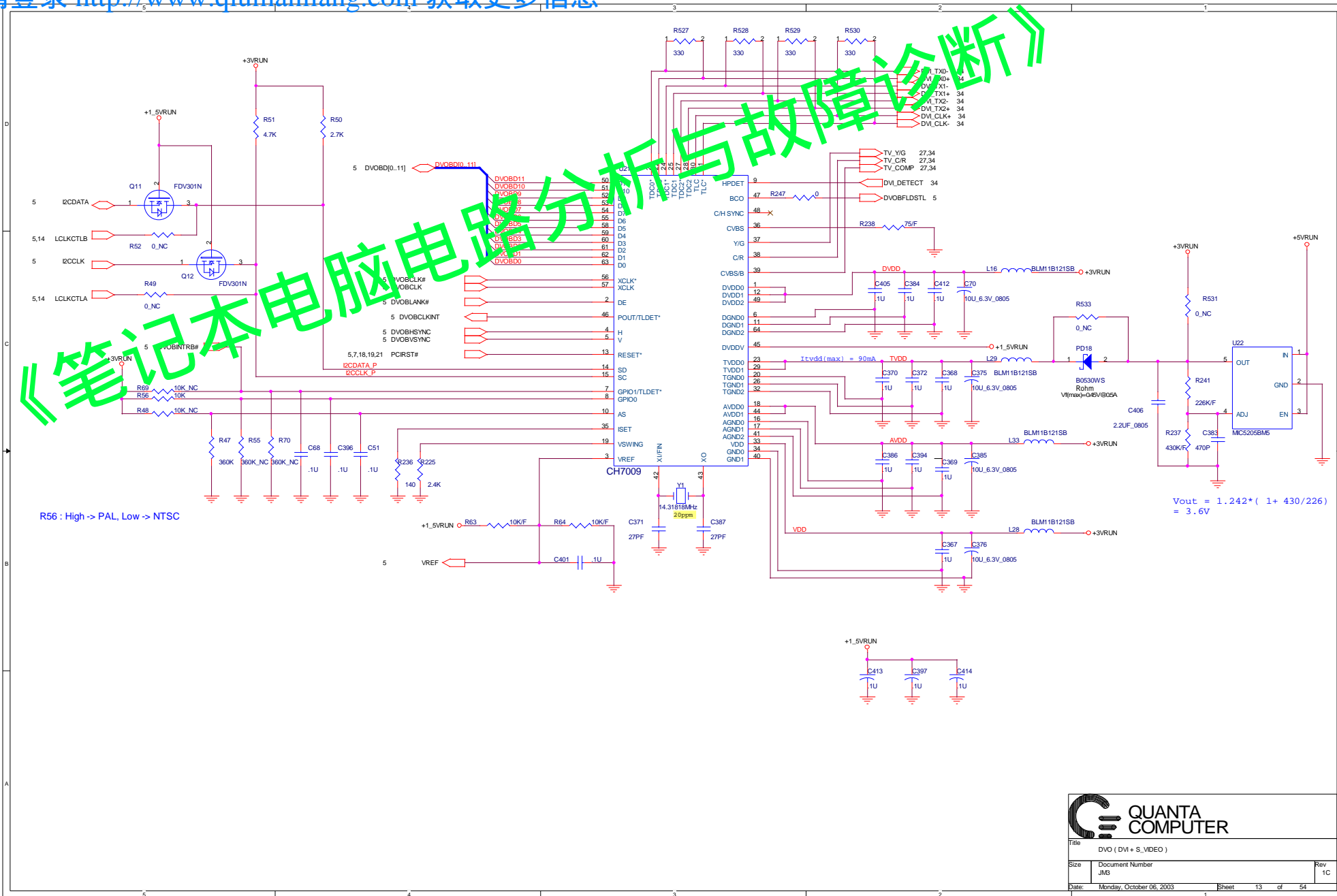

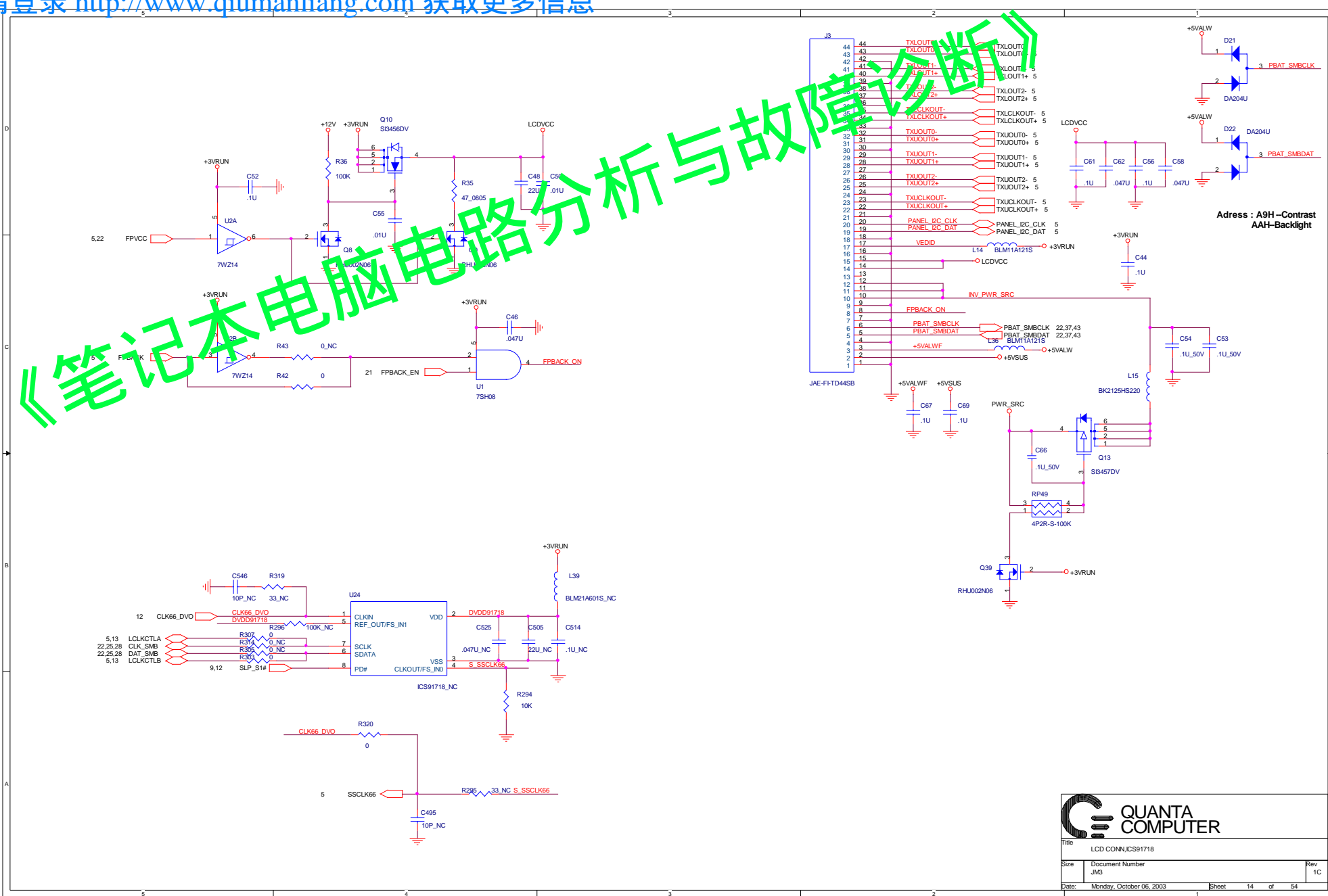

《笔记本电脑电路分析与故障诊断》

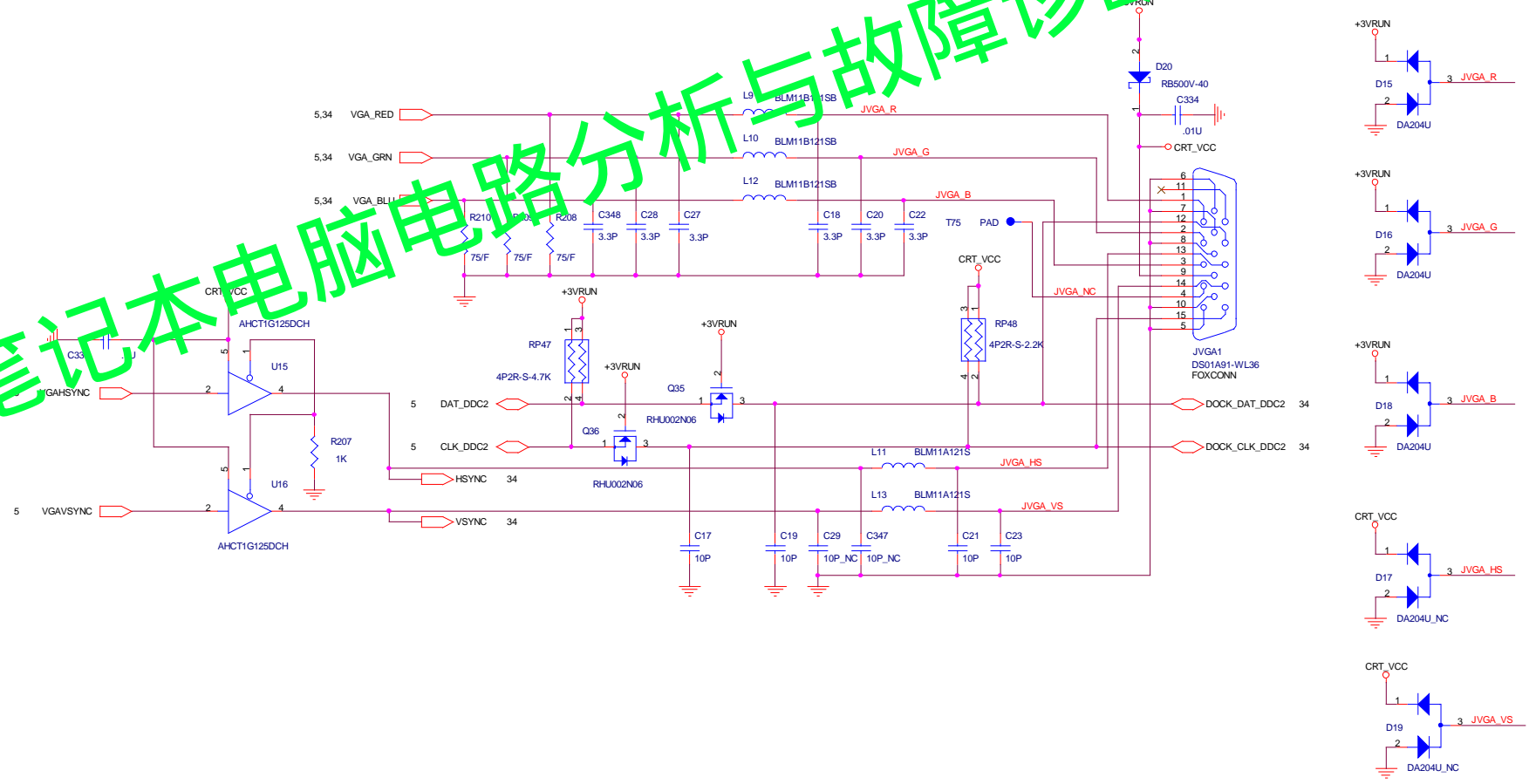

QUANTA COMPUTER

Title: CRT CONN		
Size: JMS	Document Number: JMS	Rev: 1D
Date: Monday, October 06, 2003	Sheet: 15	of 54

《笔记本电脑电路分析与故障诊断》

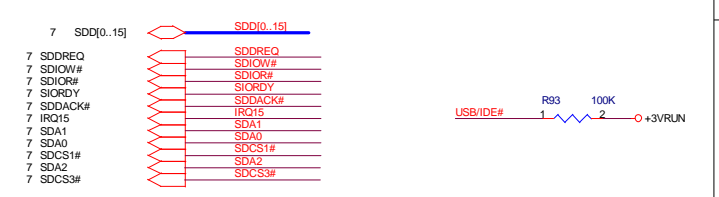
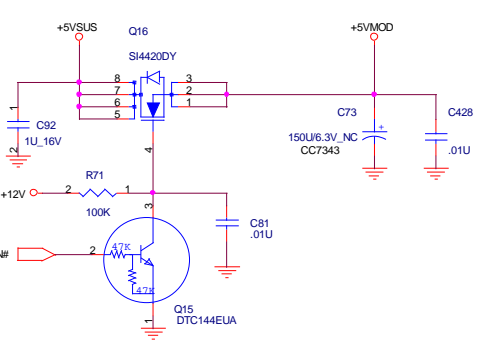
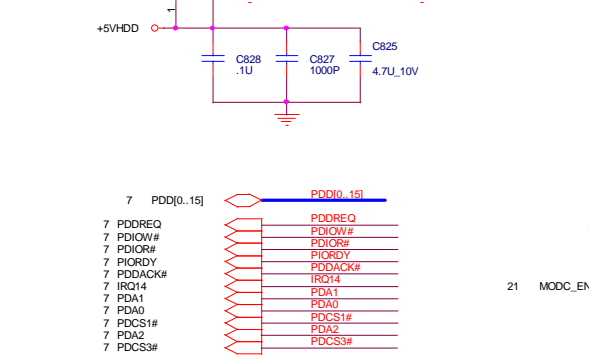
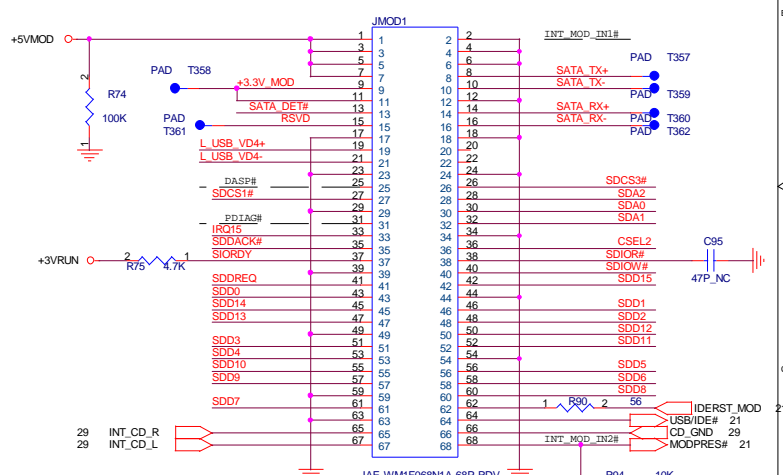
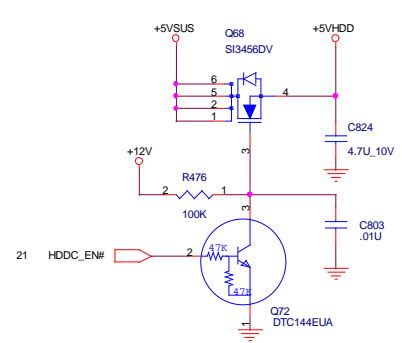
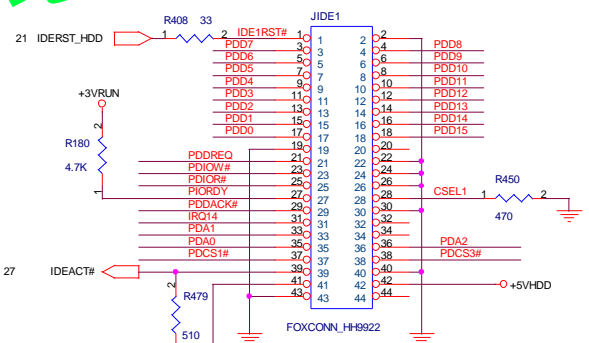
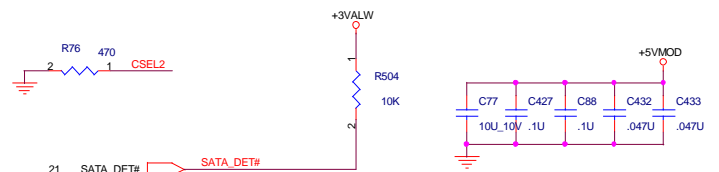
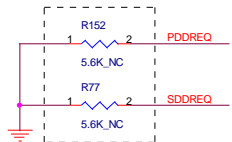

QUANTA COMPUTER

Title: IDE (HDD&CD_ROM)

Size	Document Number	Rev
	JMS	2A

Date: Monday, October 06, 2003 Sheet 16 of 54

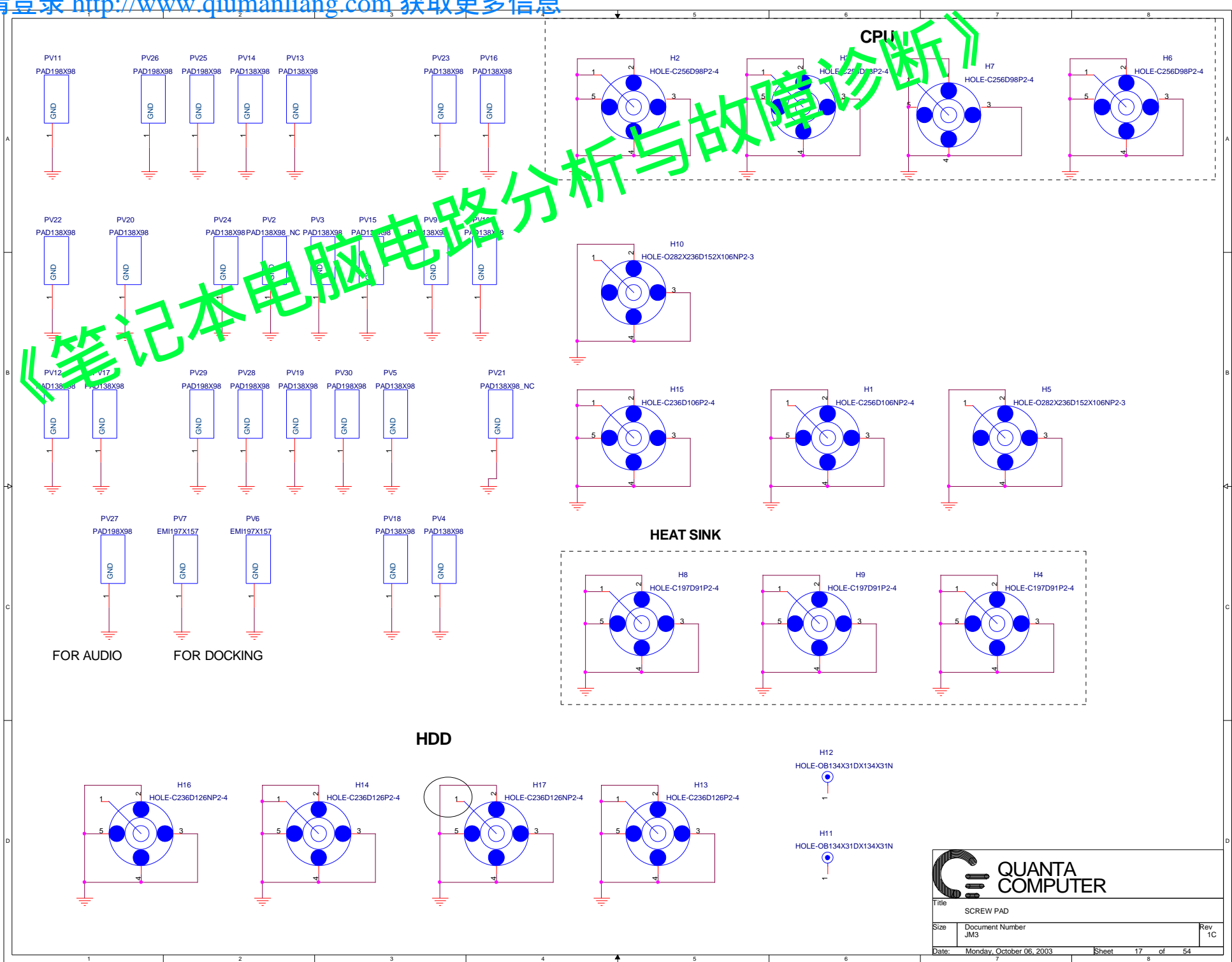

Title: SCREW PAD		
Size: JM3	Document Number:	Rev: 1C
Date: Monday, October 06, 2003	Sheet: 17	of 54

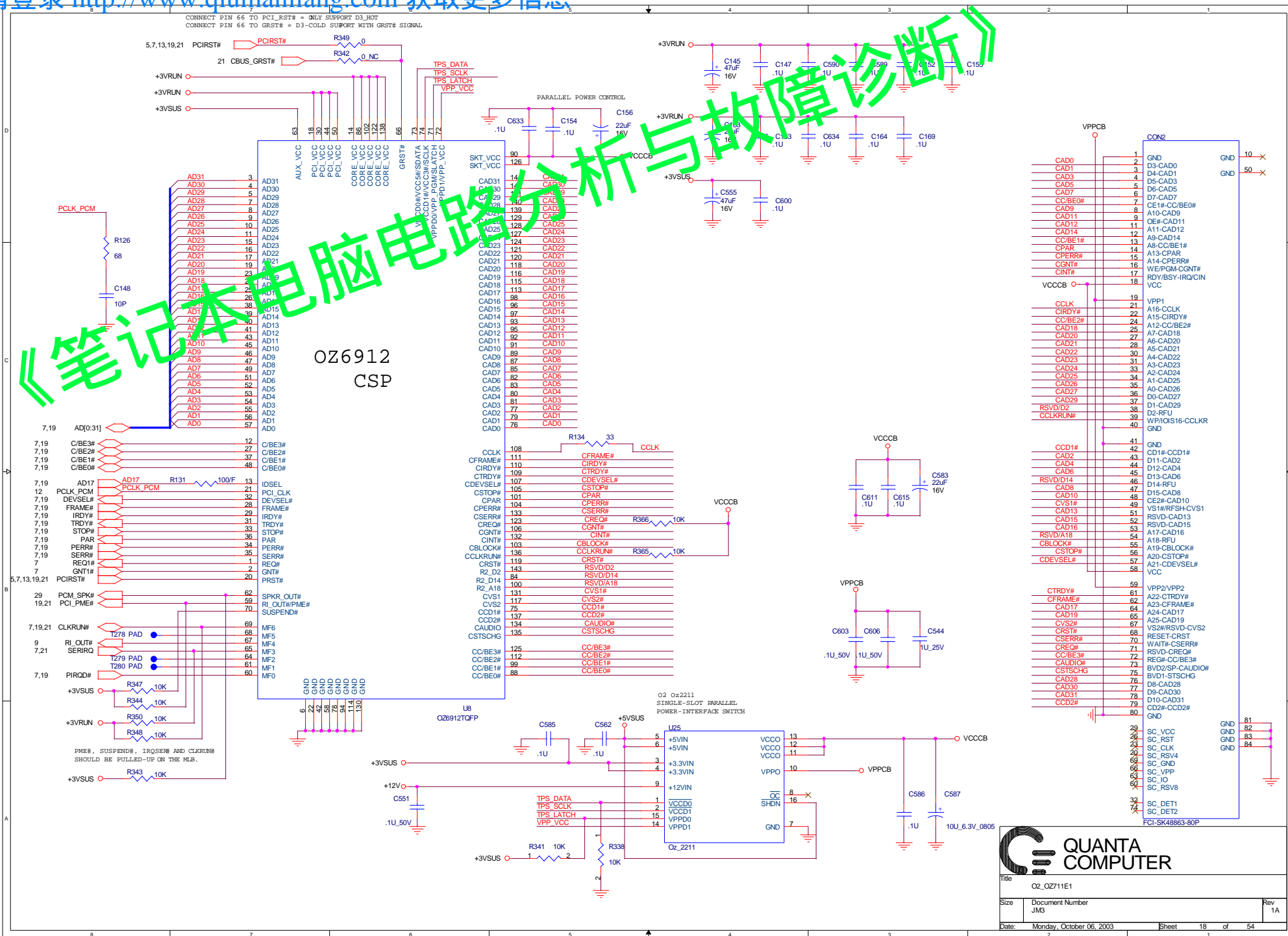

QUANTA COMPUTER

Title: OZ_0Z711E1

Size	Document Number	Rev
JM3		1A

Date: Monday, October 06, 2003 Sheet 18 of 54

《笔记本电脑电路分析与故障诊断》

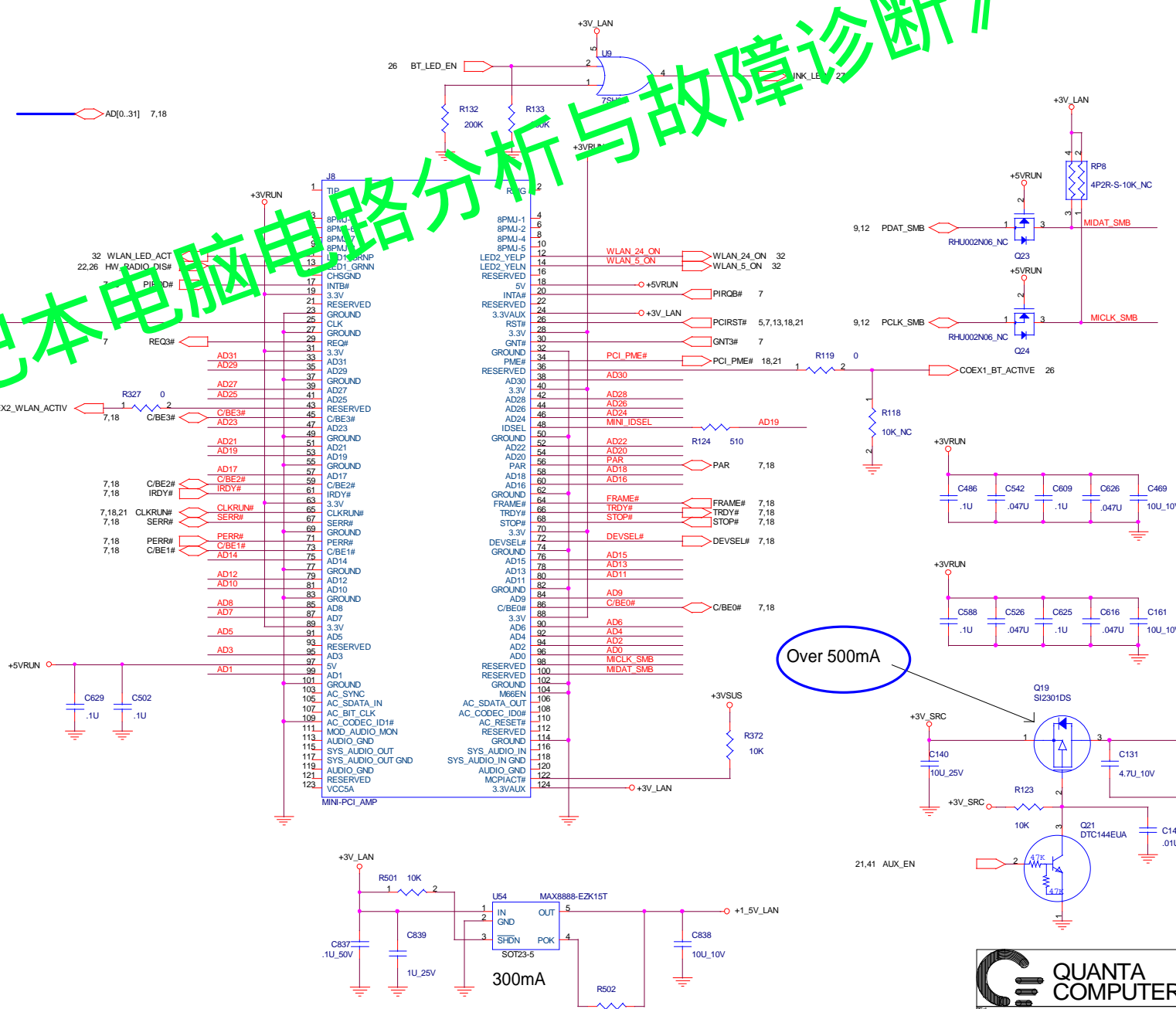

Over 500mA



Title: MINI-PCI &MDC		
Size: Document Number	Rev: 2A	
Date: Monday, October 06, 2003		
Sheet: 19		of 54

《笔记本电脑电路分析与故障诊断》

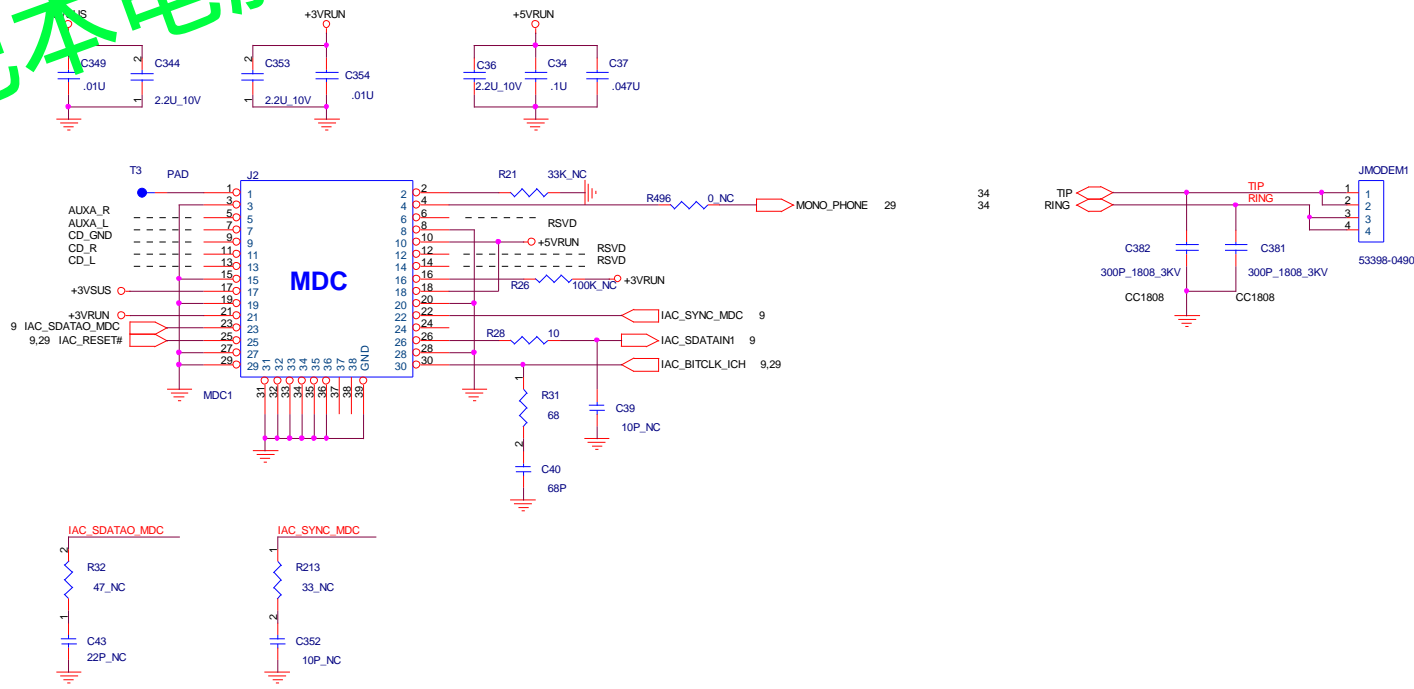

Title		MDC CONN.
Size	Document Number	Rev
	JMS	2C
Date:	Monday, October 06, 2003	Sheet 20 of 54

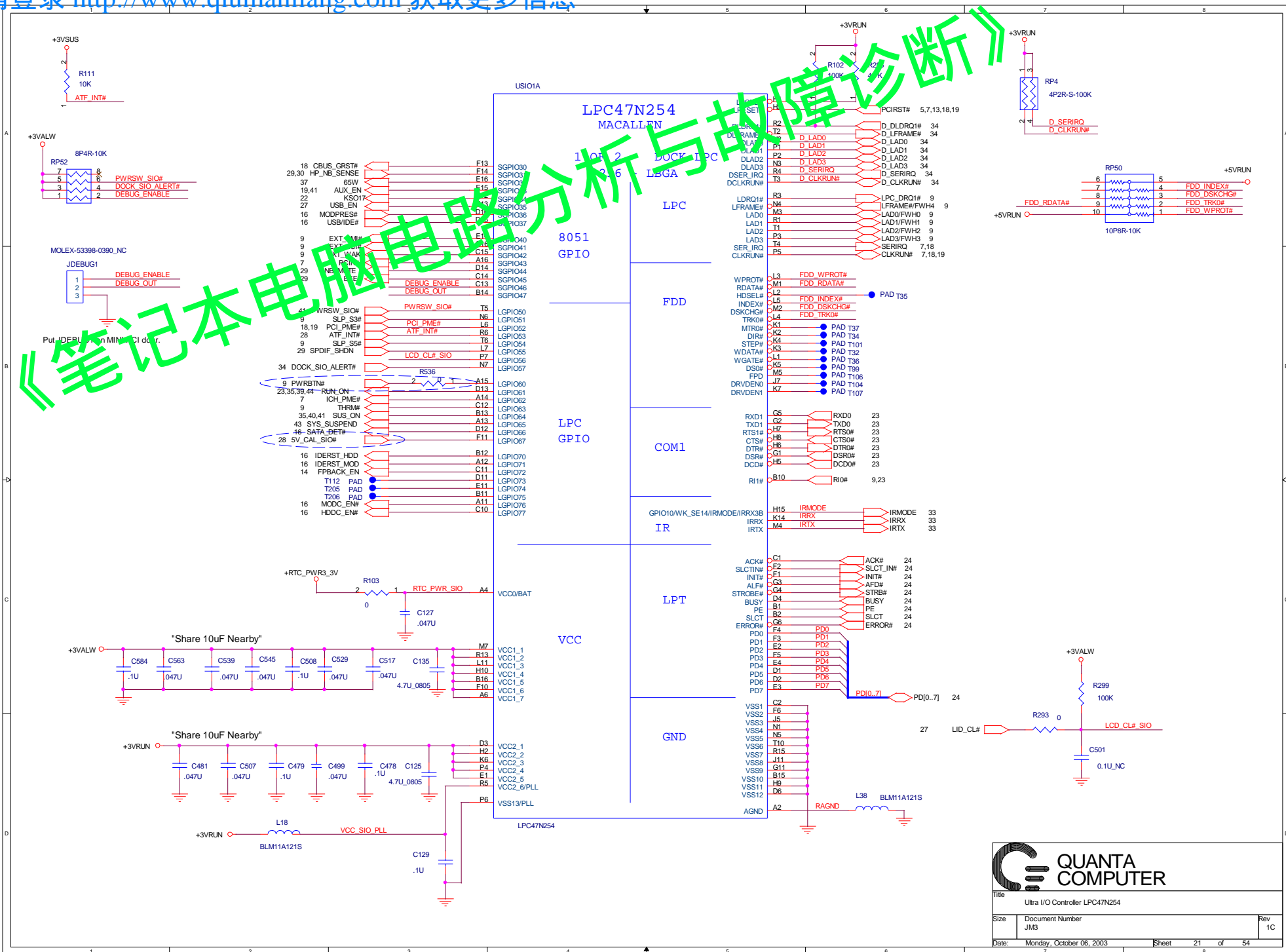

QUANTA COMPUTER

Title: Ultra I/O Controller LPC47N254

Size	Document Number	Rev
	JMS	1C

Date: Monday, October 06, 2003 Sheet 21 of 54

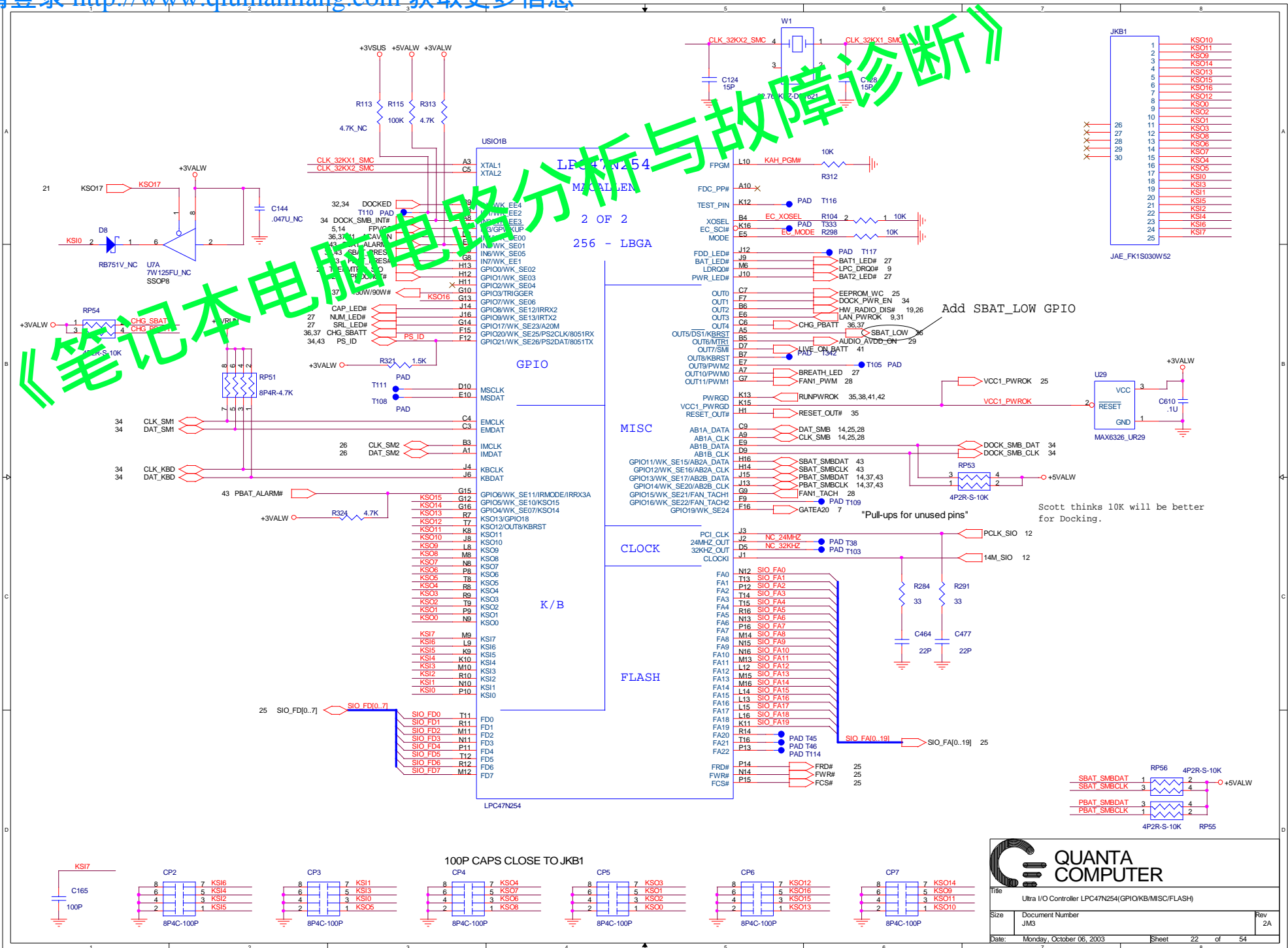

QUANTA COMPUTER

Title: Ultra I/O Controller LPC47N254(GPIO/KB/MISC/FLASH)

Size: Document Number JMS Rev 2A

Date: Monday, October 06, 2003 Sheet 22 of 54

《笔记本电脑电路分析与故障诊断》

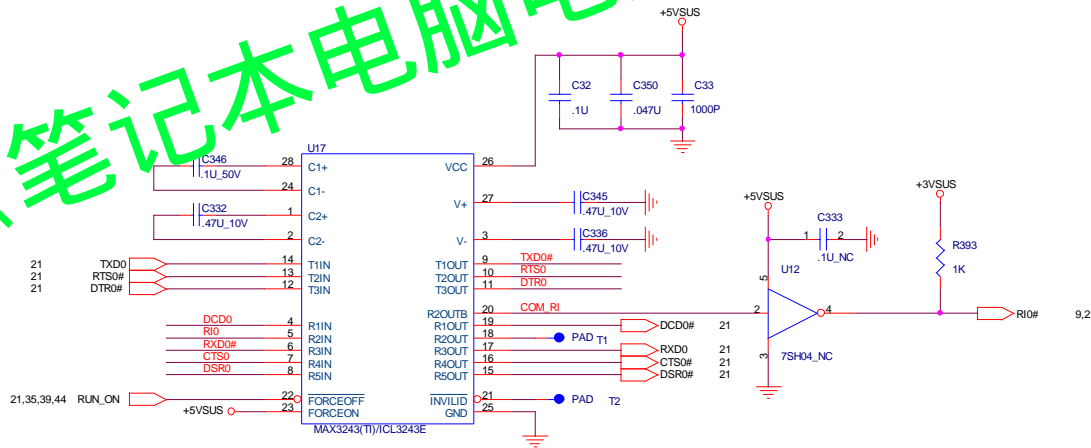

If MAX3243 pin 22 tied to RUN_ON, then it can not support Ring Out

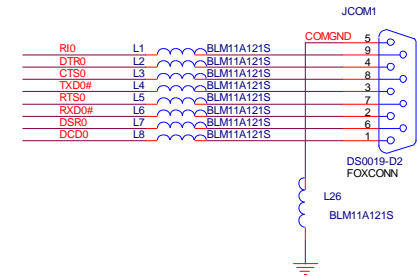

Place these beads to JCOM1 as close as possible



Title		SERIAL PORT	
Size	Document Number	Rev	
	JMS	1C	
Date:	Monday, October 06, 2003	Sheet	23 of 54

《笔记本电脑电路分析与故障诊断》

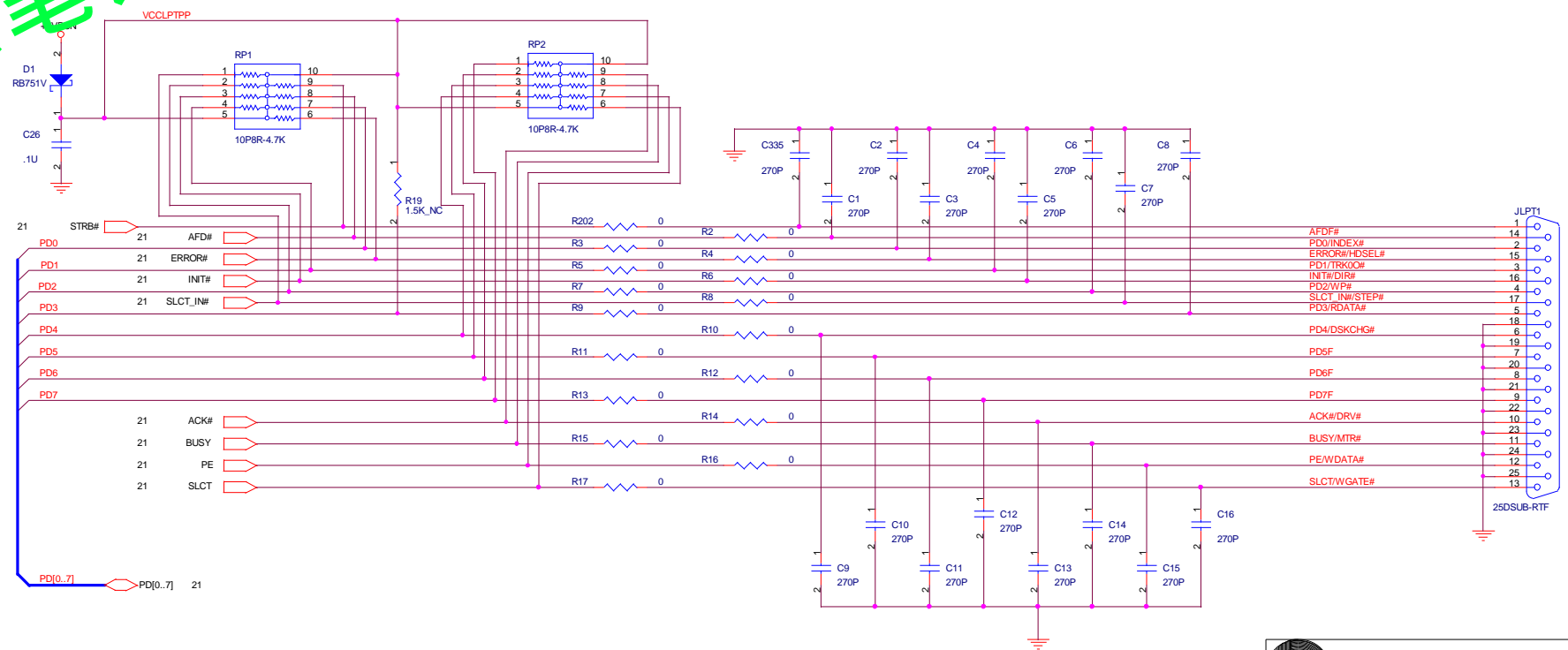

QUANTA COMPUTER

Title: PARALLEL CONN.

Size	Document Number	Rev
	JMS	1C

Date: Monday, October 06, 2003 Sheet 24 of 54

DA0JM2MBCA1

《笔记本电脑电路分析与故障诊断》

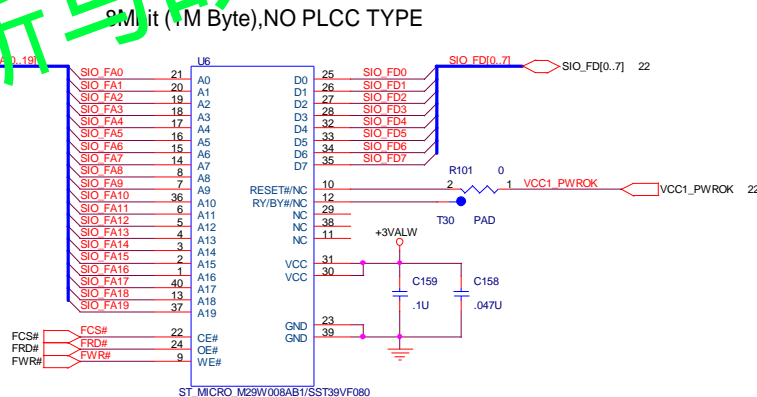
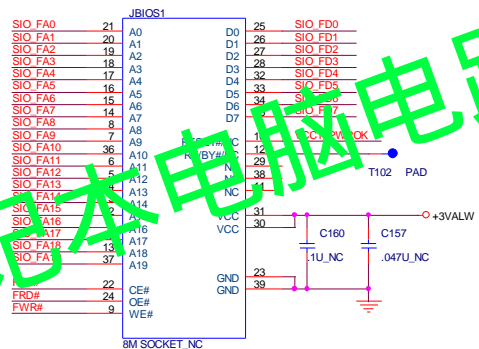

SST :Pin10,12 are NC

- 1.MAX6326_UR29 has >100ms reset timing.So we can tie its reset# pin to +3VALW directly.
- 2.SIO has internal 20 mS delay of VCC1_PWROK

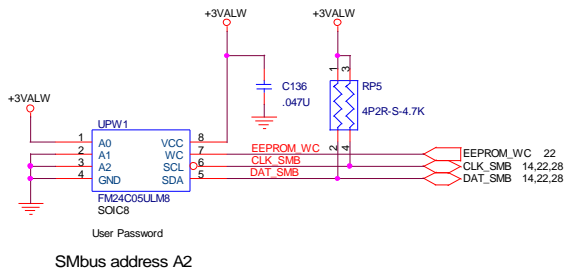

QUANTA COMPUTER

Title: FLASH

Size	Document Number	Rev
	JMS	1C

Date: Monday, October 06, 2003 Sheet 25 of 54

《笔记本电脑电路分析与故障诊断》

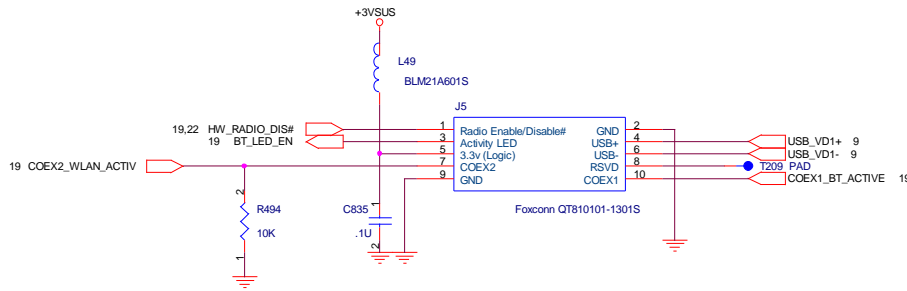
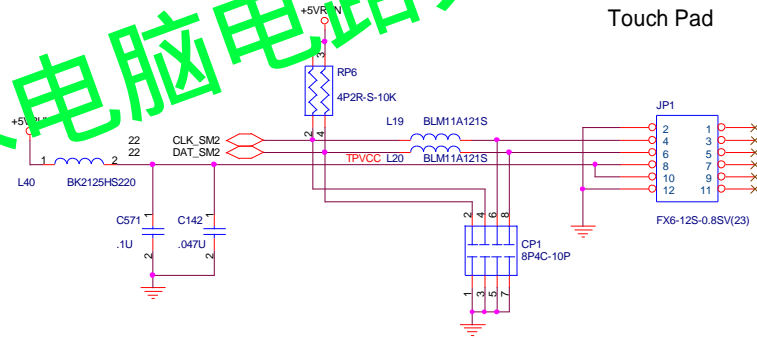

Title		TOUCH PAD & BULE TOOTH
Size	Document Number	Rev
	JMS	1C
Date:	Monday, October 06, 2003	Sheet 26 of 54

《笔记本电脑电路分析与故障诊断》

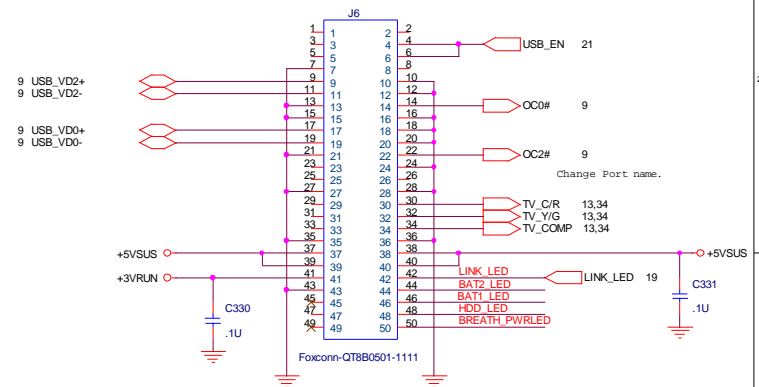
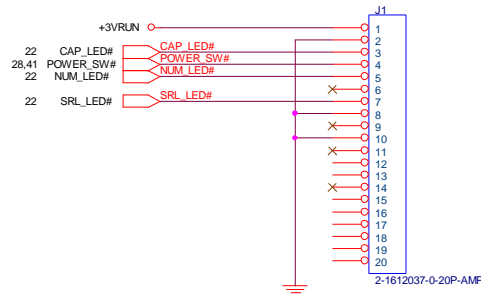
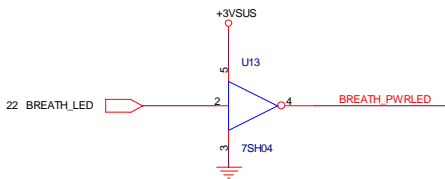
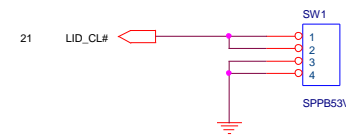
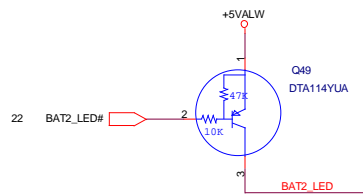
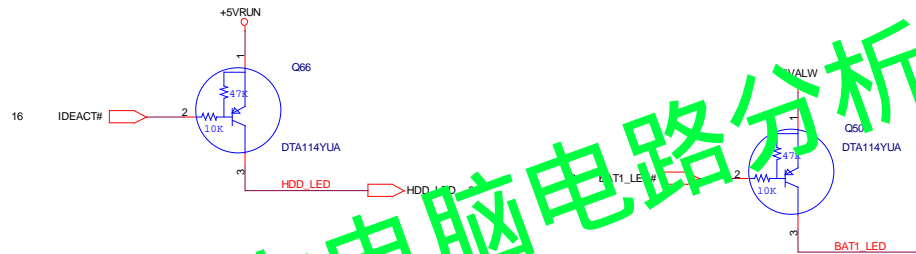

Title		SWITCH & LED	
Size	Document Number	Rev	
	JMS	1C	
Date:	Monday, October 06, 2003	Sheet	27 of 54

《笔记本电脑电路分析与故障诊断》

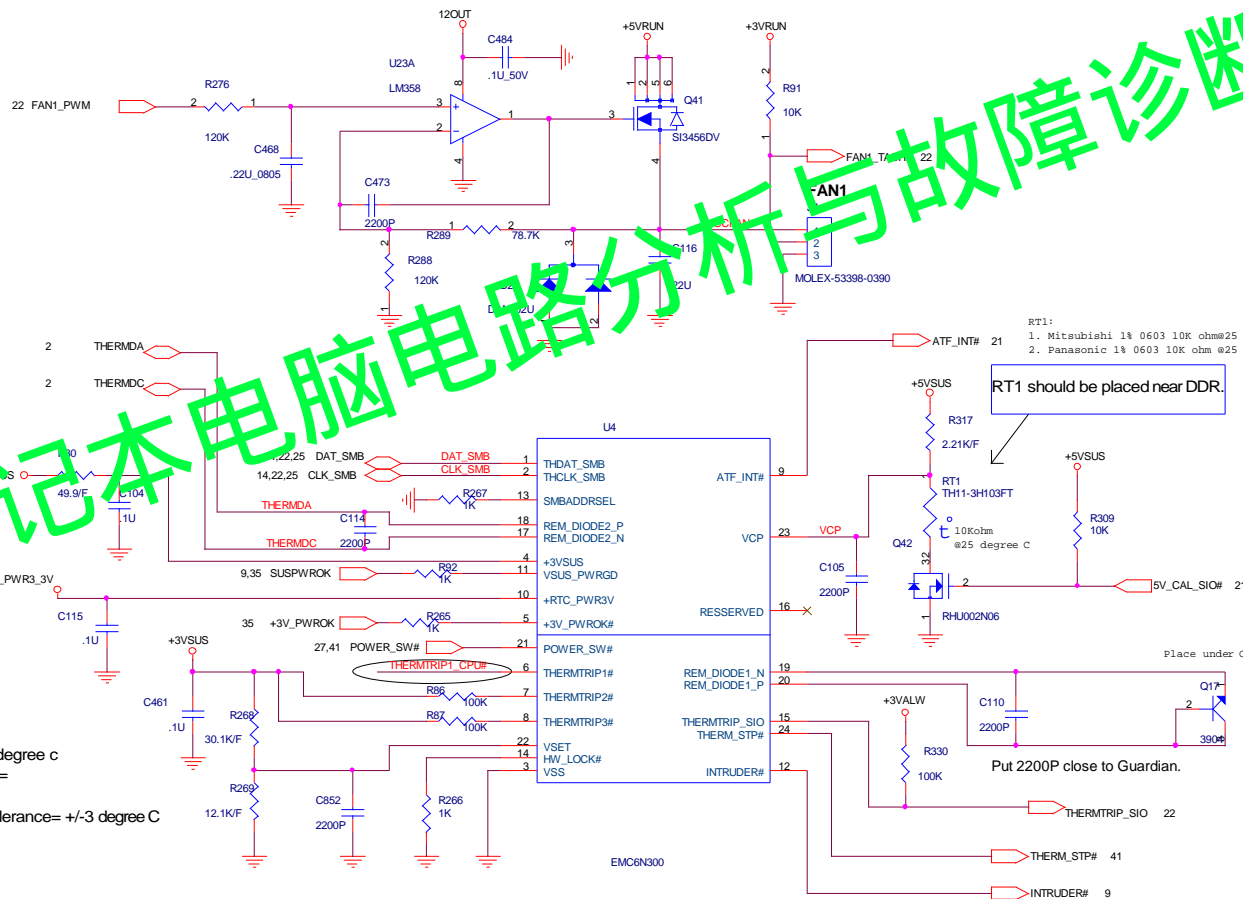

Notes:
 $V_{set} = (T_p - 75) / 16$
 Where $T_p = 75$ to 106 degree C
 Set trip point = 90 degree C
 $V_{set} = (90 - 75) / 16 = 0.9375$ V
 Guardian temp-tolerance = ± 3 degree C

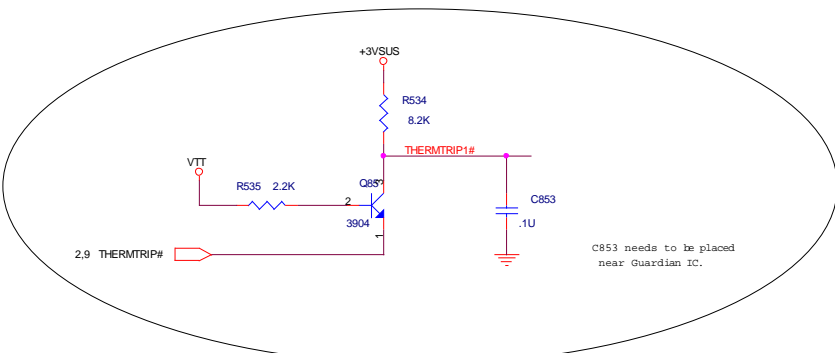

QUANTA COMPUTER

Title: FAN & THERMAL

Size: Document Number JMS Rev 1C

Date: Monday, October 06, 2003 Sheet 28 of 54

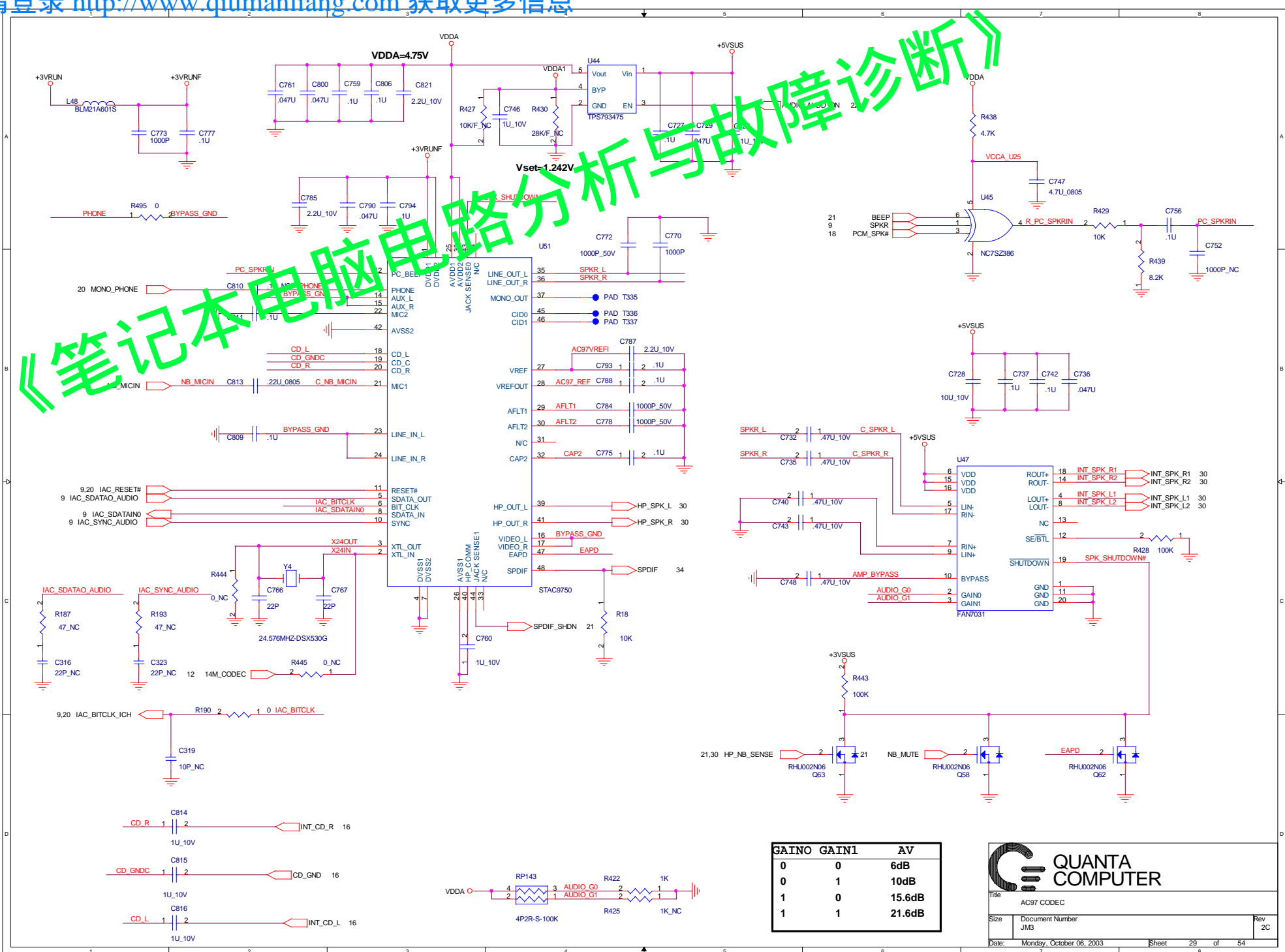

《笔记本电脑电路分析与故障诊断》

GAIN	GAIN1	AV
0	0	6dB
0	1	10dB
1	0	15.6dB
1	1	21.6dB

QUANTA COMPUTER

Title: AC97 CODEC

Size: Document Number JMS

Date: Monday, October 06, 2003

Sheet: 29 of 54

Rev: 2C

《笔记本电脑电路分析与故障诊断》

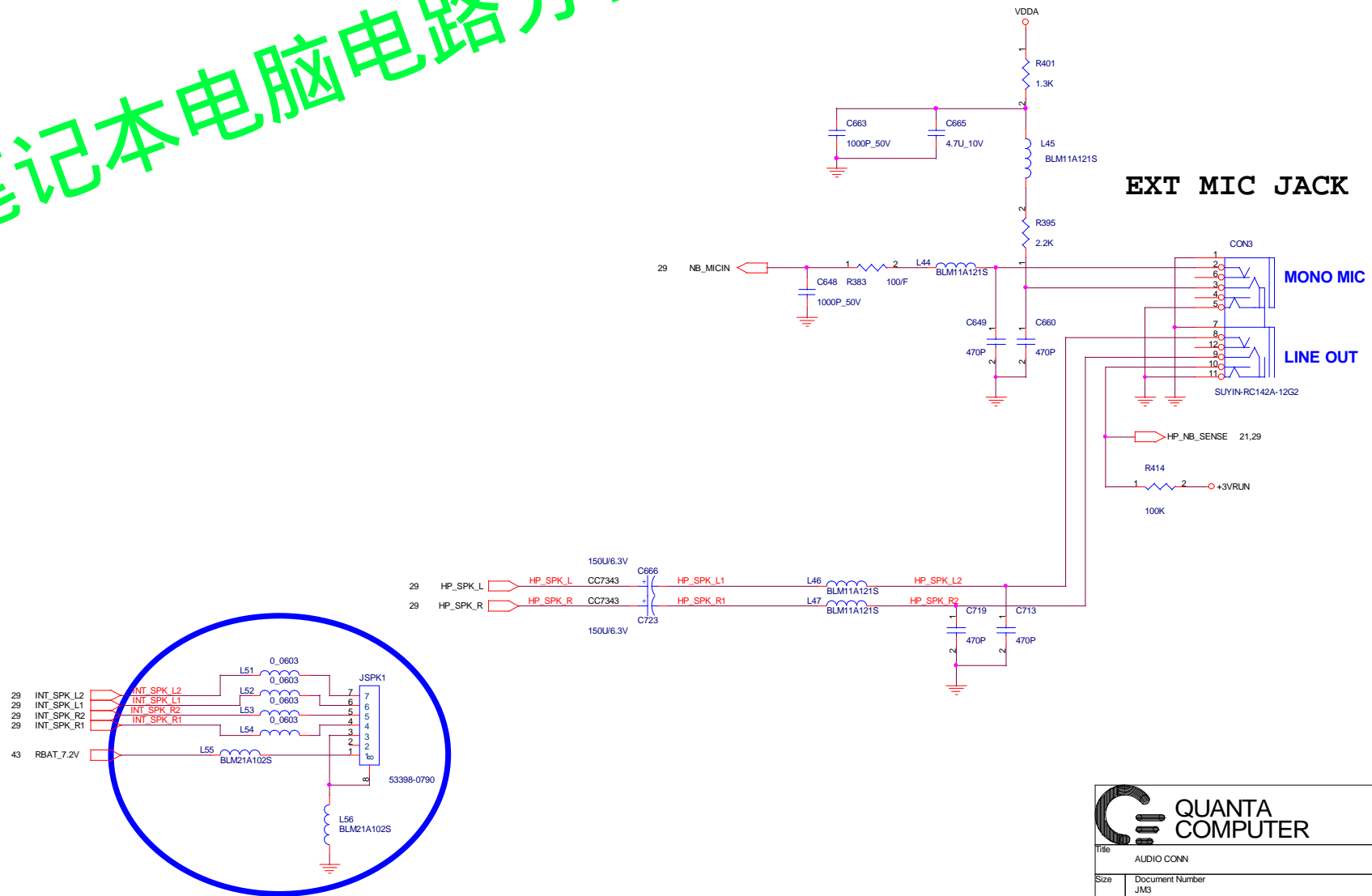

QUANTA COMPUTER

Title: AUDIO CONN

Size	Document Number	Rev
	JMS	1C

Date: Monday, October 06, 2003 Sheet 30 of 54

《笔记本电脑电路分析与故障诊断》

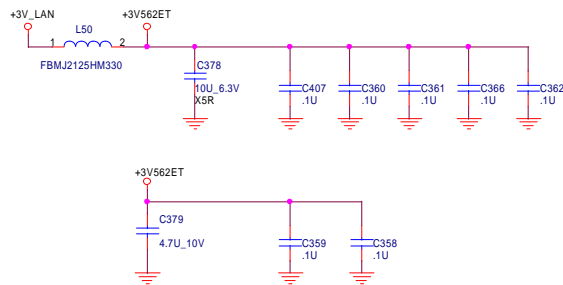
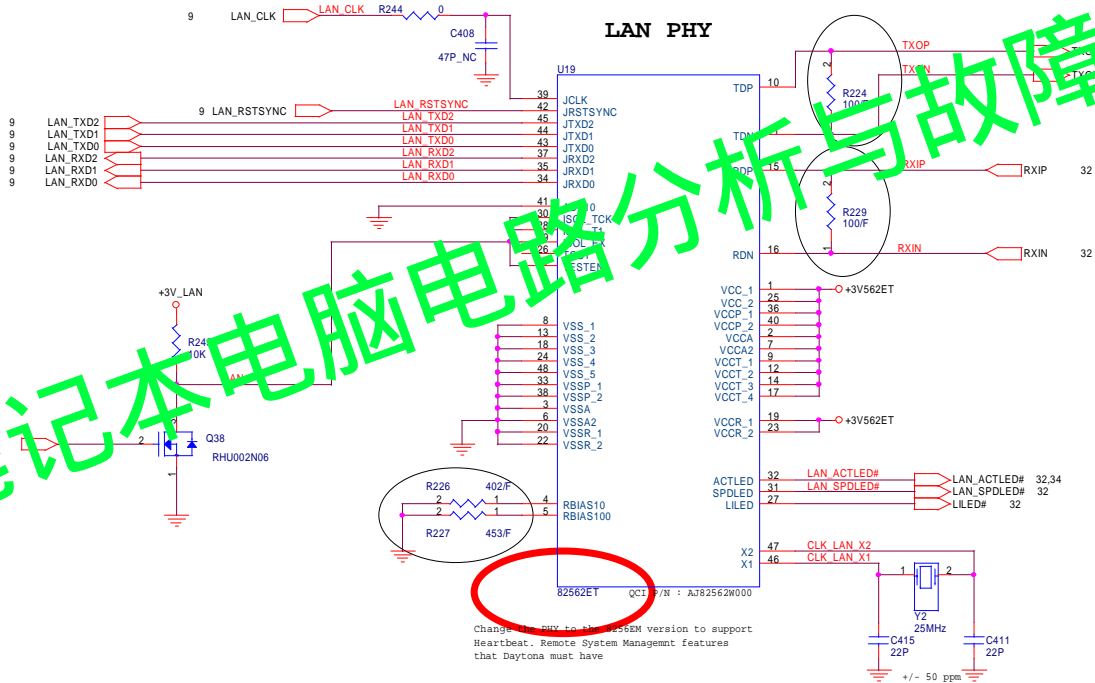

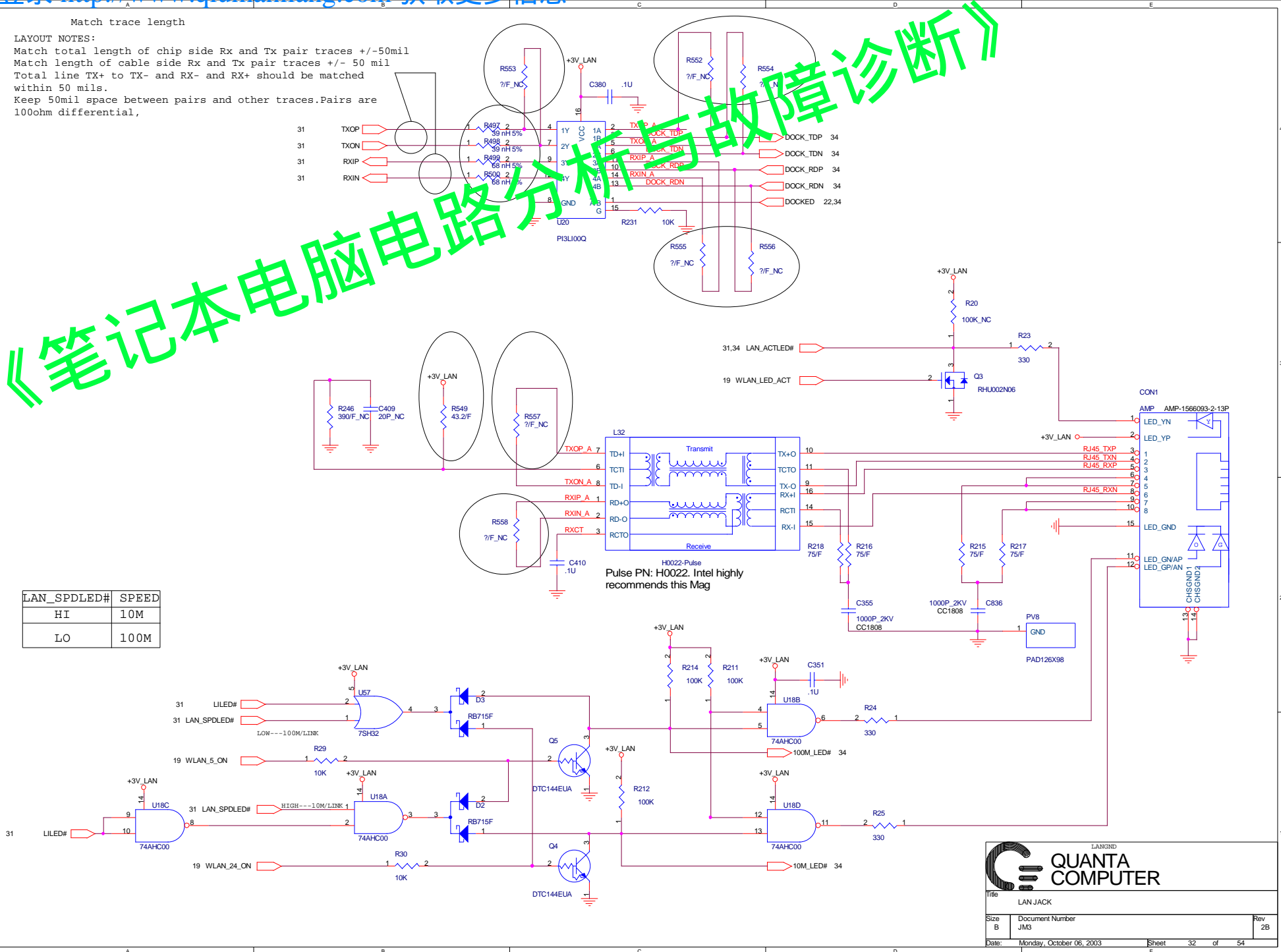

 QUANTA COMPUTER		
Title: LAN INTERFACE		
Size: Custom	Document Number: JM3	Rev: 2B
Date: Monday, October 06, 2003	Sheet: 31	of 54

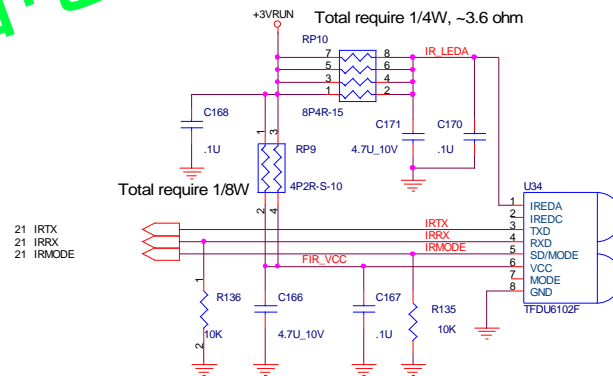

《笔记本电脑电路分析与故障诊断》

《笔记本电脑电路分析与故障诊断》



 **QUANTA
COMPUTER**

Title: FIR

Size	Document Number JMS	Rev 1C
------	------------------------	-----------

Date: Monday, October 06, 2003 Sheet 33 of 54

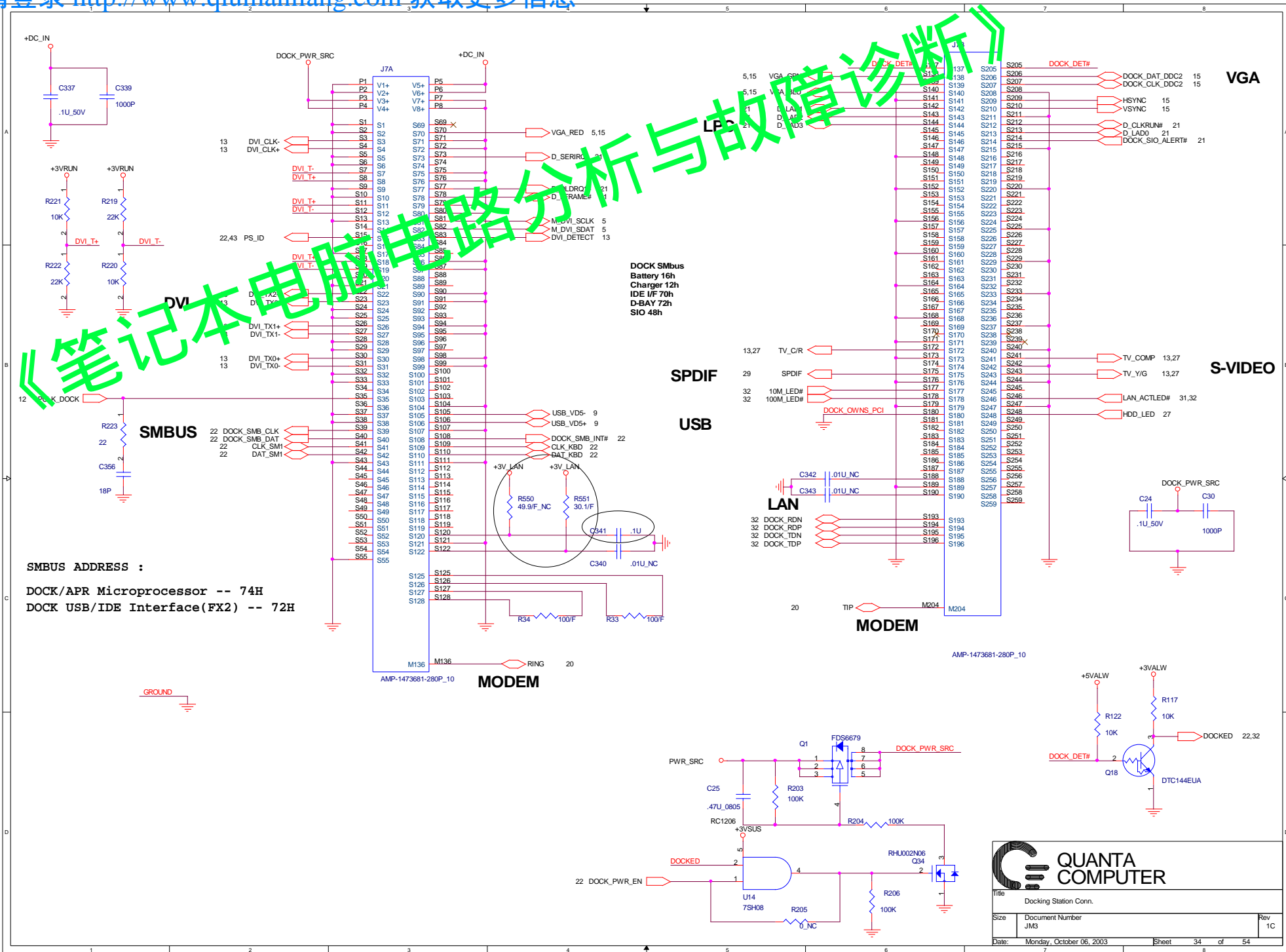

《笔记本电脑电路分析与故障诊断》

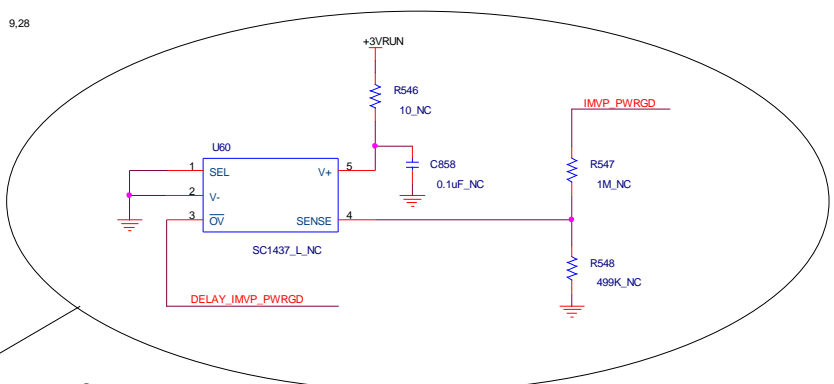
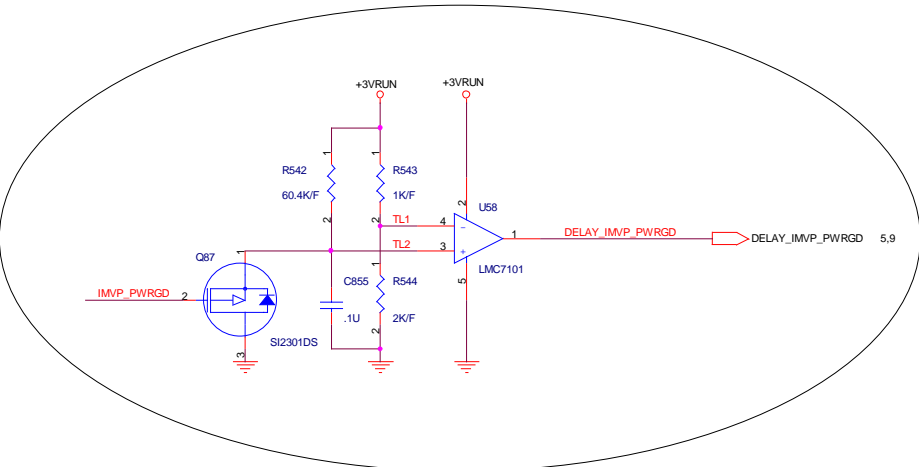
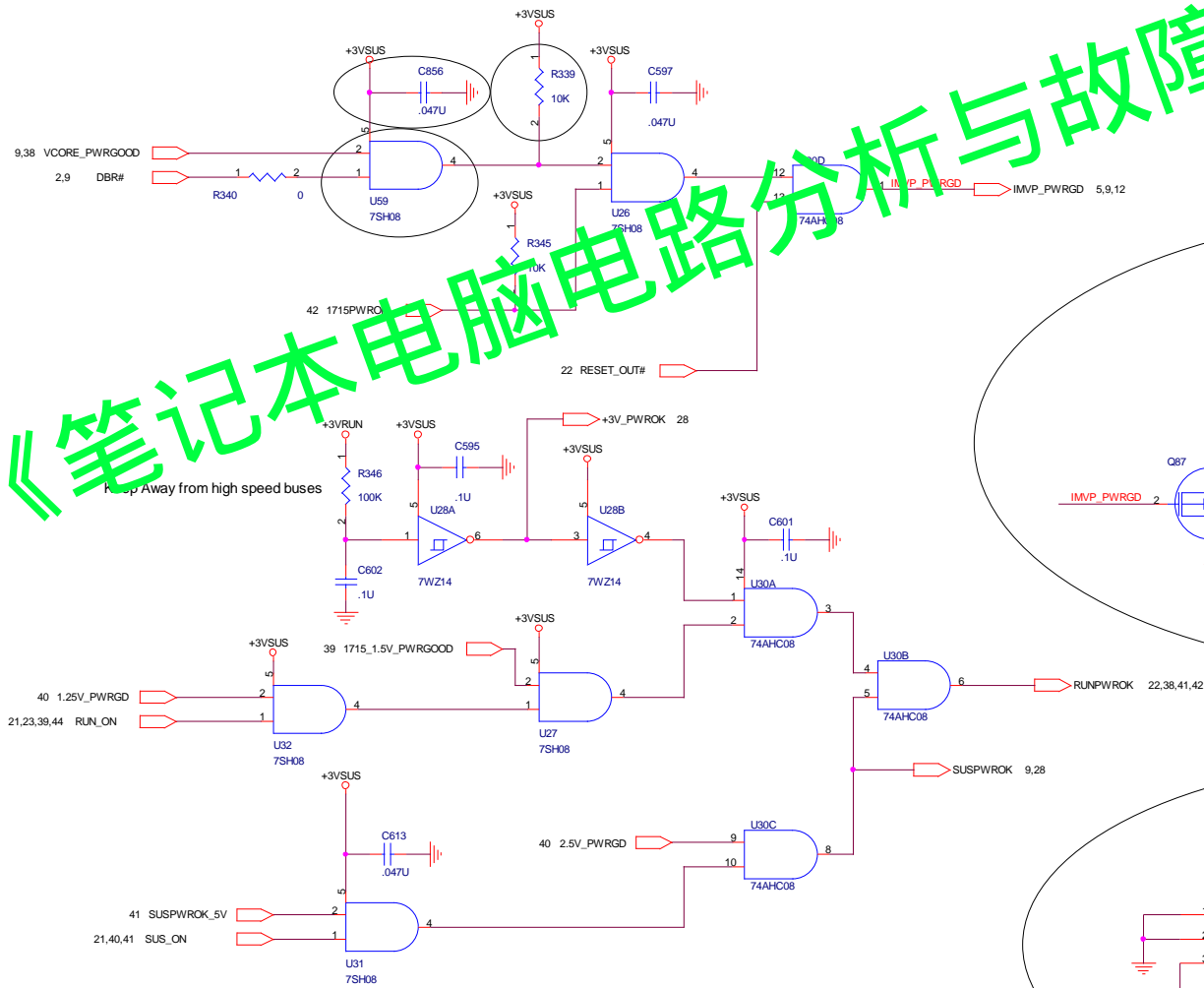

Delay IMVP PWRGR 0~40mS for cost down



Title			POWER GOOD
Size	Document Number	Rev	
	JMS	1C	
Date:	Monday, October 06, 2003	Sheet	35 of 54

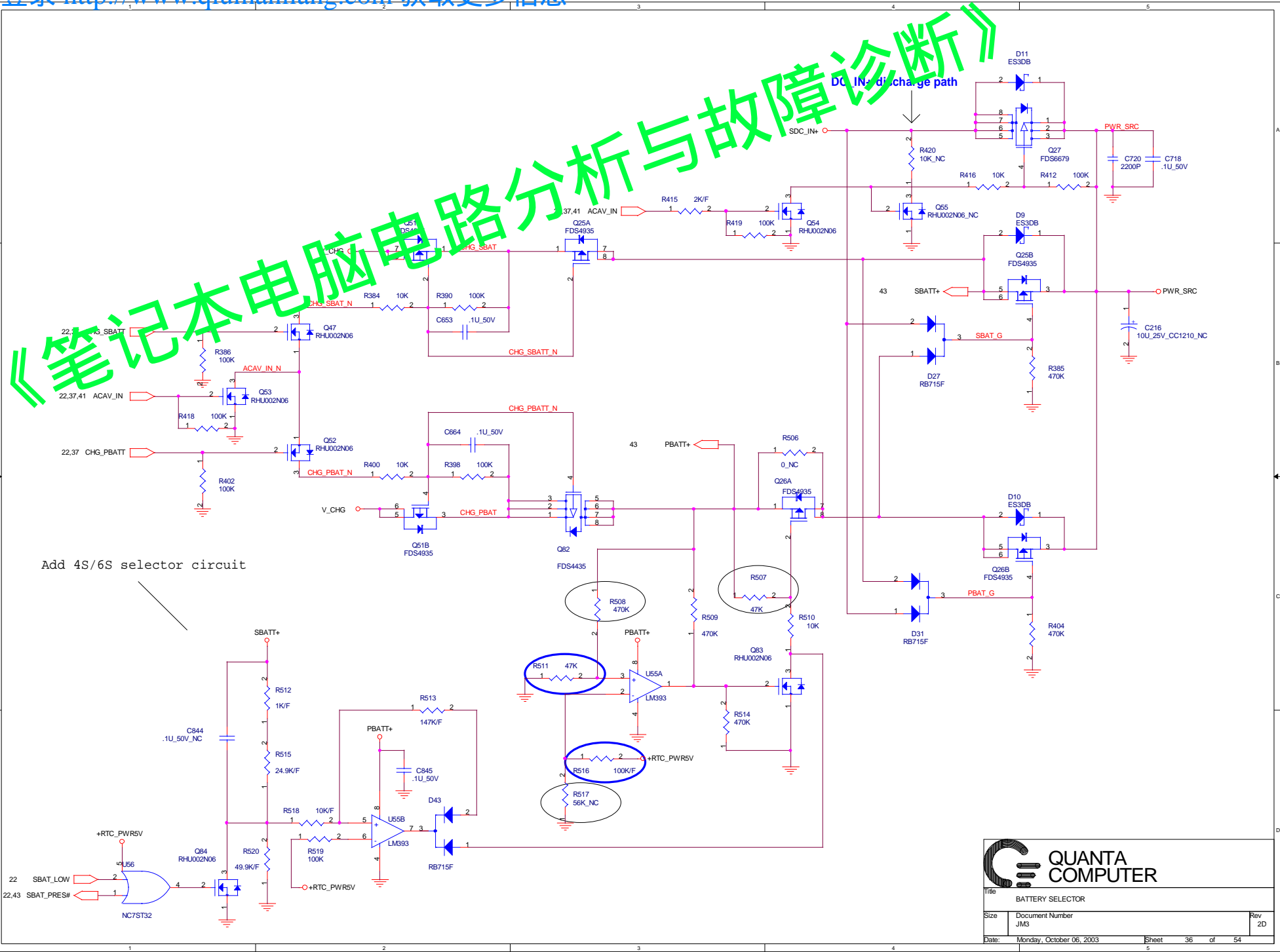

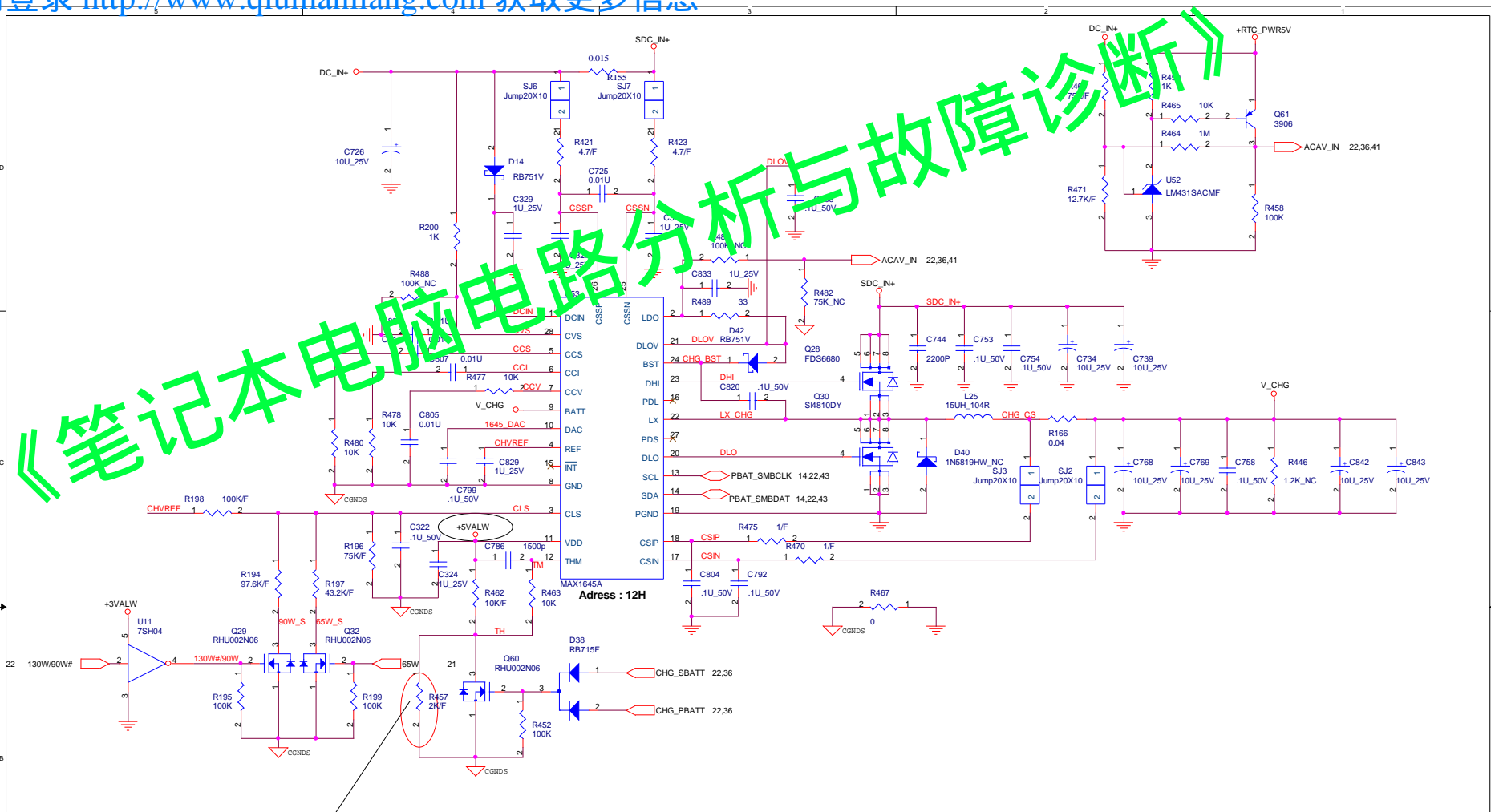

The value as Bonid, will check with Maxim again.

	65W (2.93A)	90W (4.0A)	130W (5.8A)
65W	H	L	L
130W/90W#	H	L	H

Change to 2.93A

QUANTA COMPUTER

Title: Battery Charger

Size: Document Number JMS Rev 2D

Date: Monday, October 06, 2003 Sheet 37 of 54

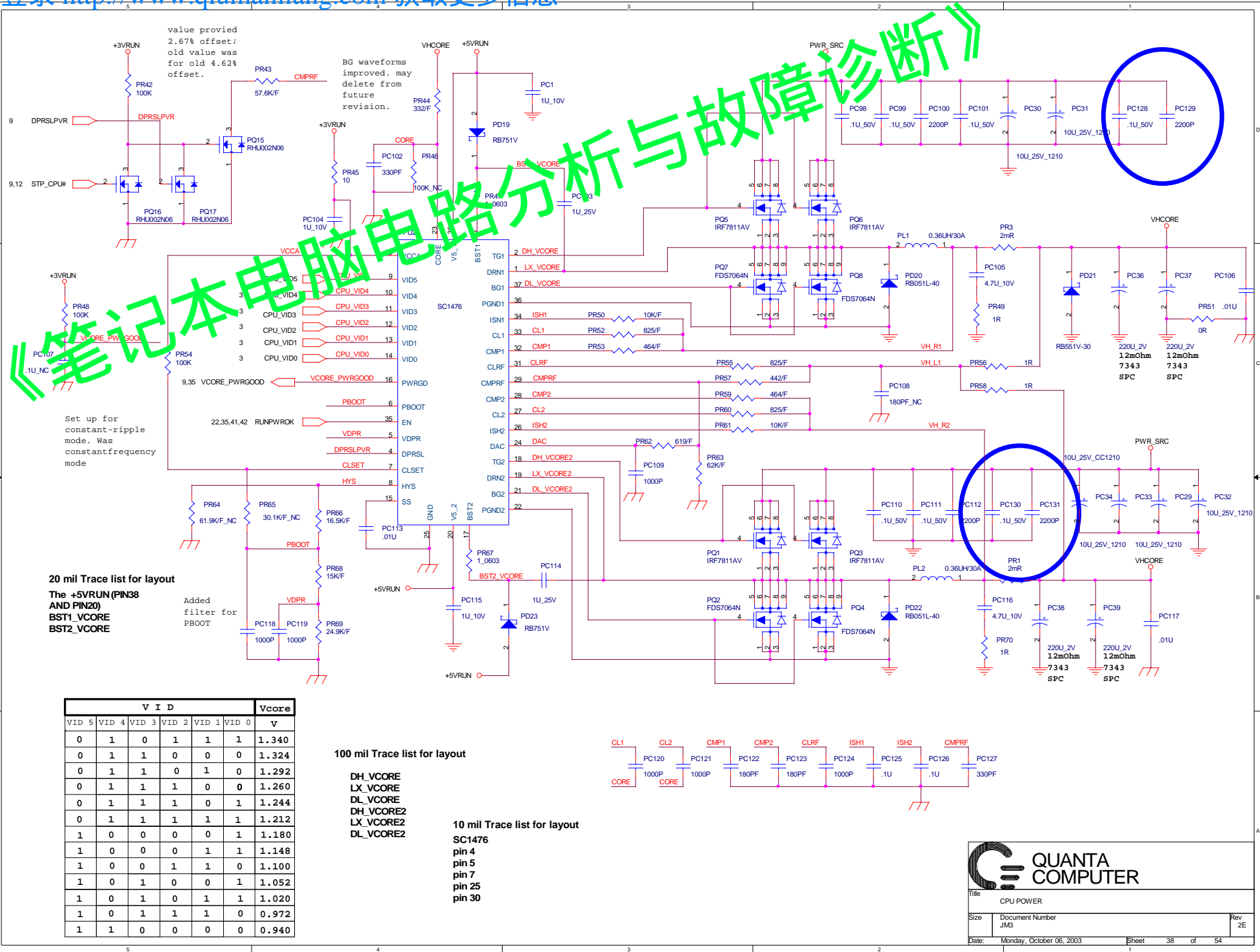

value provided
2.67% offset;
old value was
for old 4.62%
offset.

BG waveforms
improved. may
delete from
future
revision.

20 mil Trace list for layout
The +5VRUN (PIN38
AND PIN20)
BST1_VCORE
BST2_VCORE

V I D							Vcore
VID 5	VID 4	VID 3	VID 2	VID 1	VID 0	ψ	ψ
0	1	0	1	1	1	1	1.340
0	1	1	0	0	0	0	1.324
0	1	1	0	1	0	0	1.292
0	1	1	1	0	0	0	1.260
0	1	1	1	0	1	1	1.244
0	1	1	1	1	1	1	1.212
1	0	0	0	0	1	1	1.180
1	0	0	0	1	1	1	1.148
1	0	0	1	1	0	0	1.100
1	0	1	0	0	0	1	1.052
1	0	1	0	1	1	1	1.020
1	0	1	1	1	0	0	0.972
1	1	0	0	0	0	0	0.940

100 mil Trace list for layout

DH_VCORE
LX_VCORE
DL_VCORE
DH_VCORE2
LX_VCORE2
DL_VCORE2

10 mil Trace list for layout

SC1476
pin 4
pin 5
pin 7
pin 25
pin 30

QUANTA COMPUTER

Title: CPU POWER

Size: Document Number JMS Rev: 2E

Date: Monday, October 06, 2003 Sheet: 38 of 54

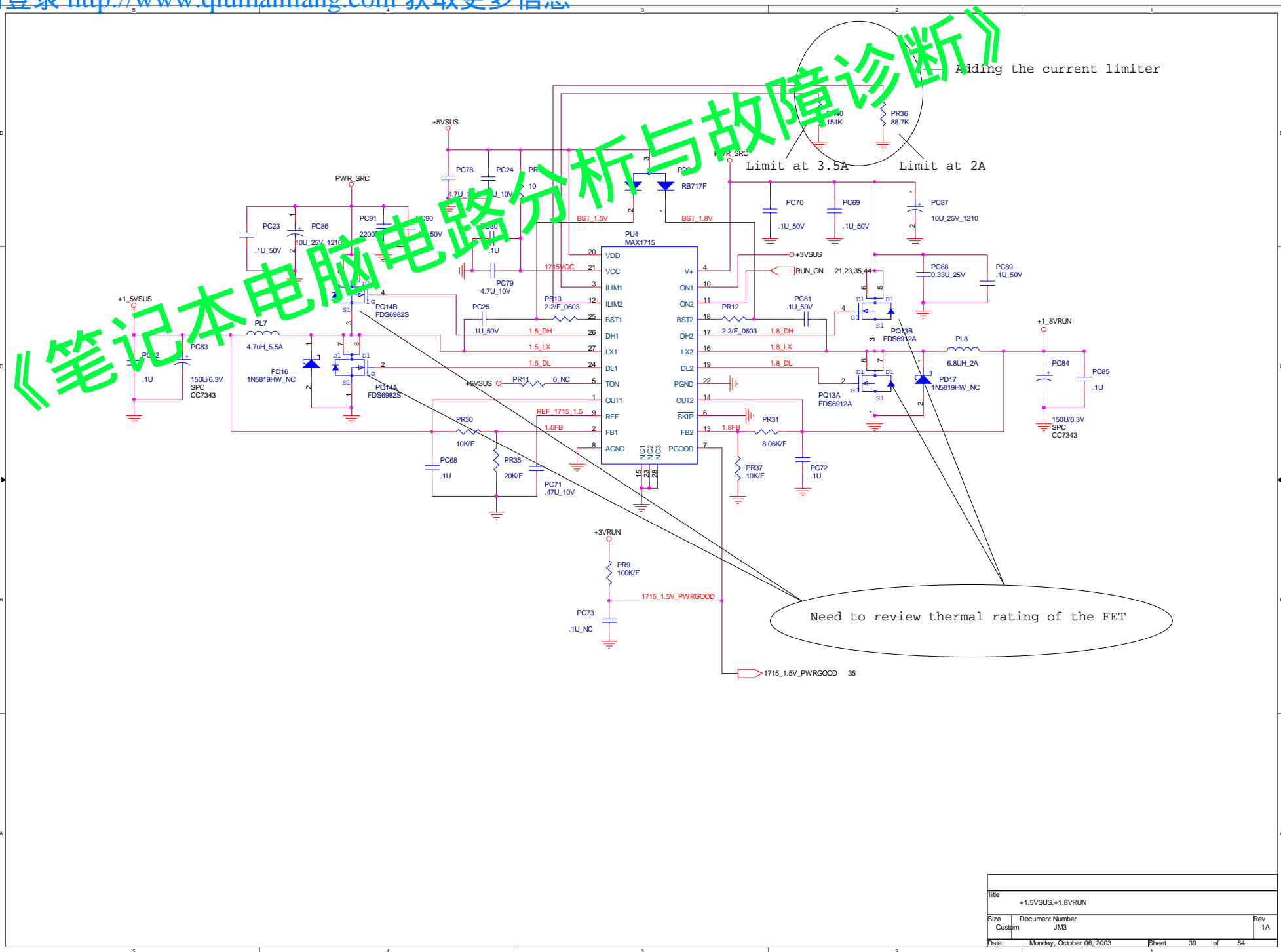

《笔记本电路分析与故障诊断》

Title		
+1.5VSUS,+1.8VRUN		
Size	Document Number	Rev
Custom	JMS	1A
Date:	Monday, October 06, 2003	Sheet 39 of 54

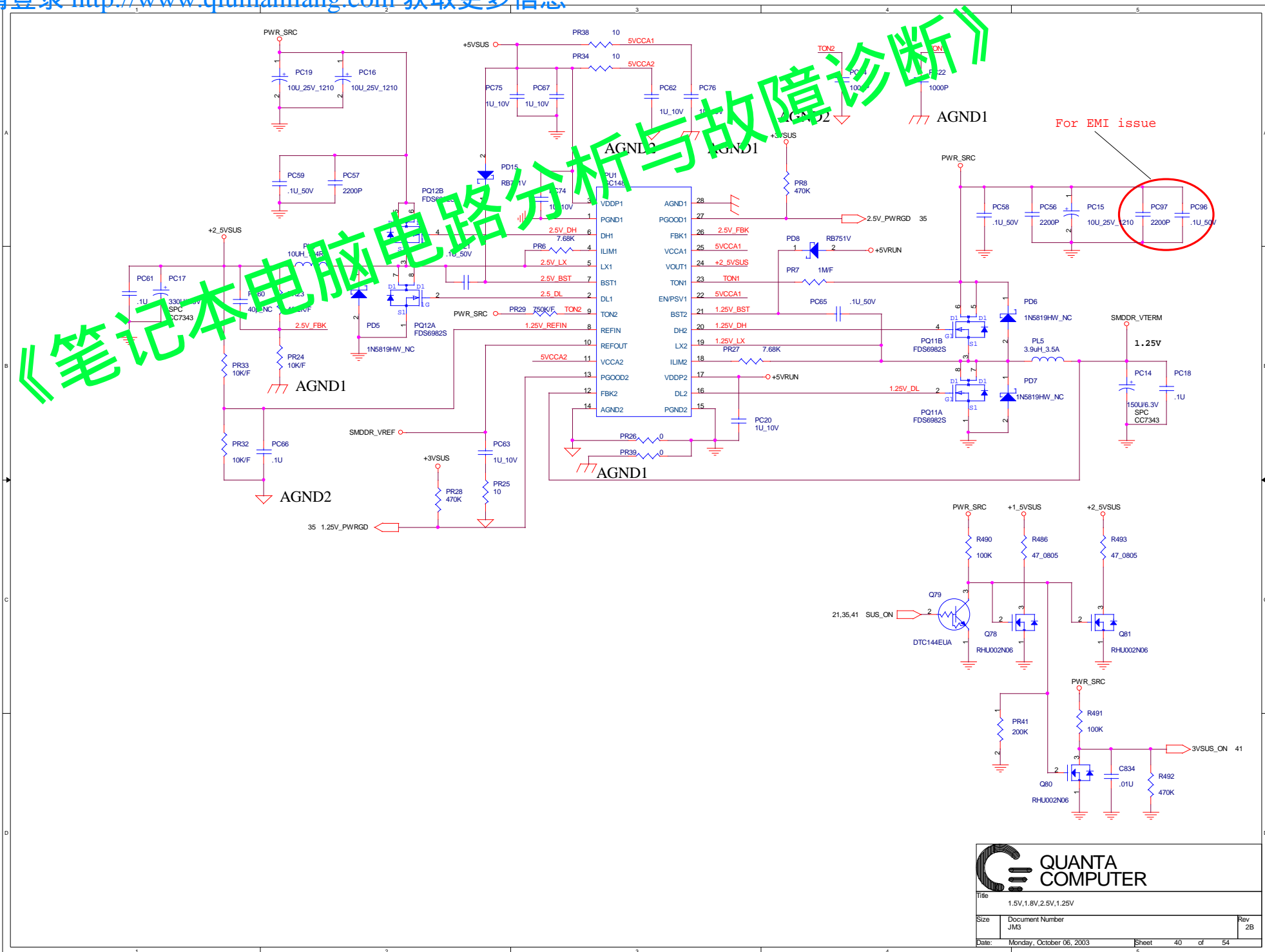

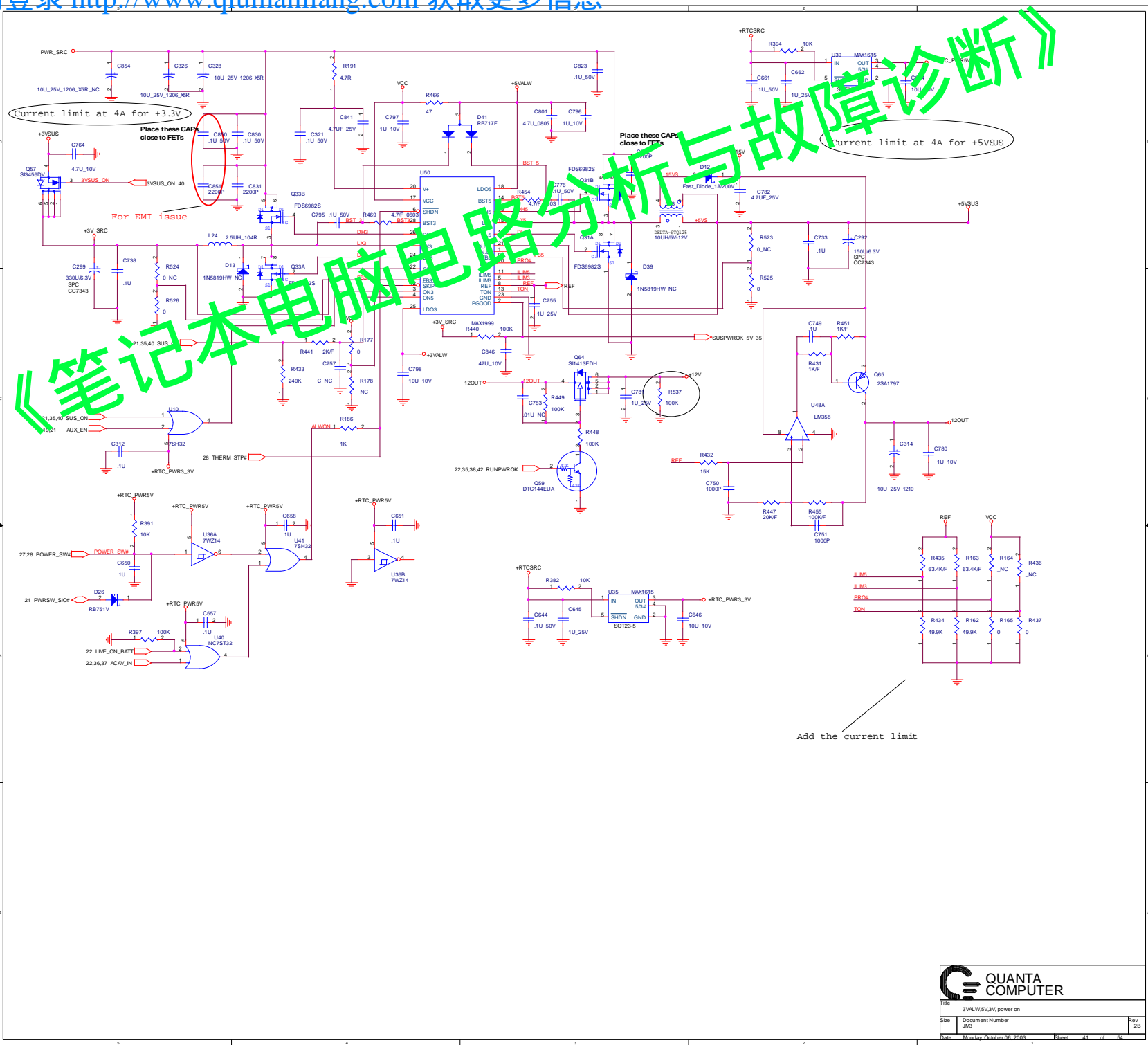

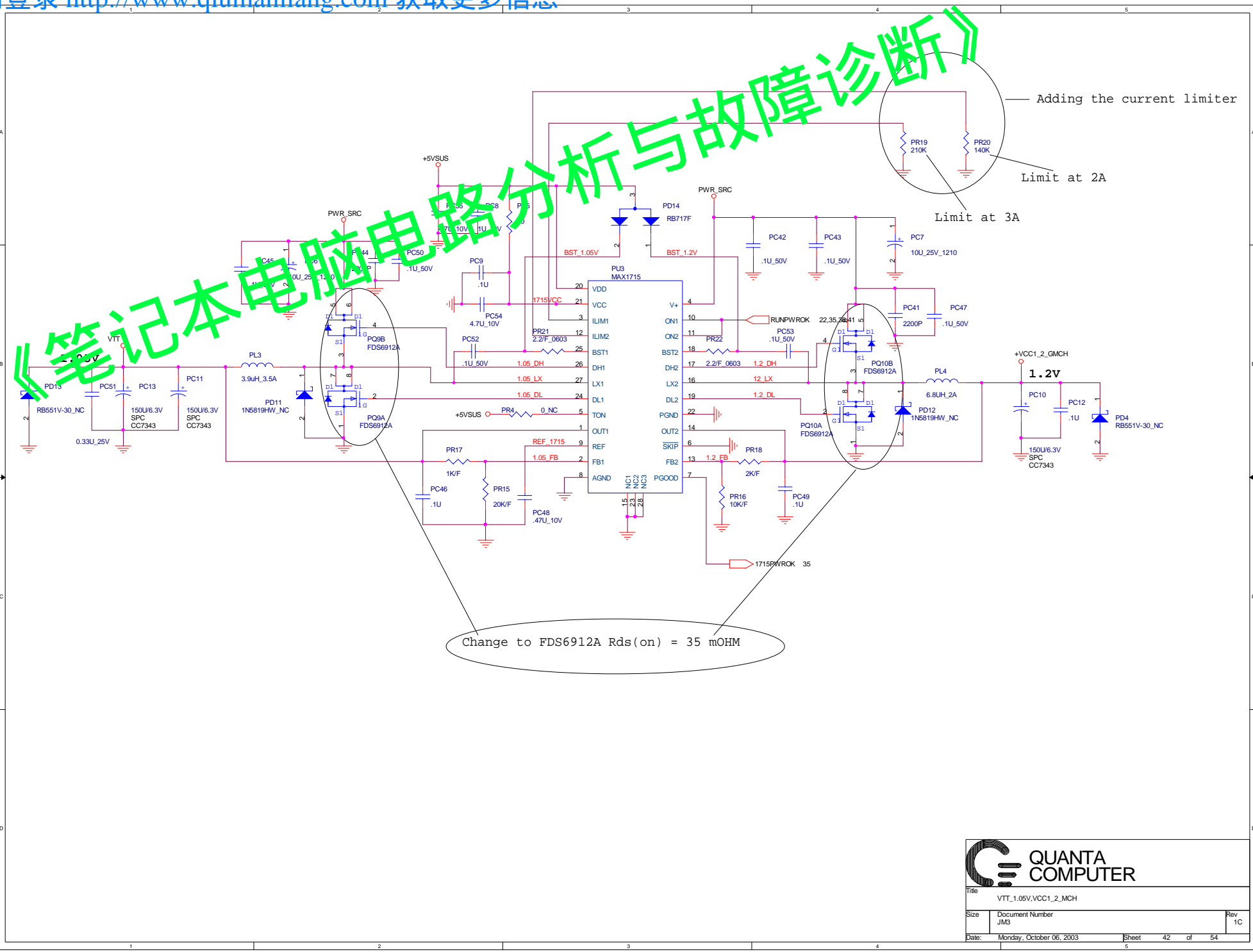

QUANTA COMPUTER

Title		
VTT_1.05V_VCC1_2_MCH		
Size	Document Number	Rev
JM3		1C
Date:	Monday, October 06, 2003	Sheet 42 of 54

《笔记本电脑电路分析与故障诊断》

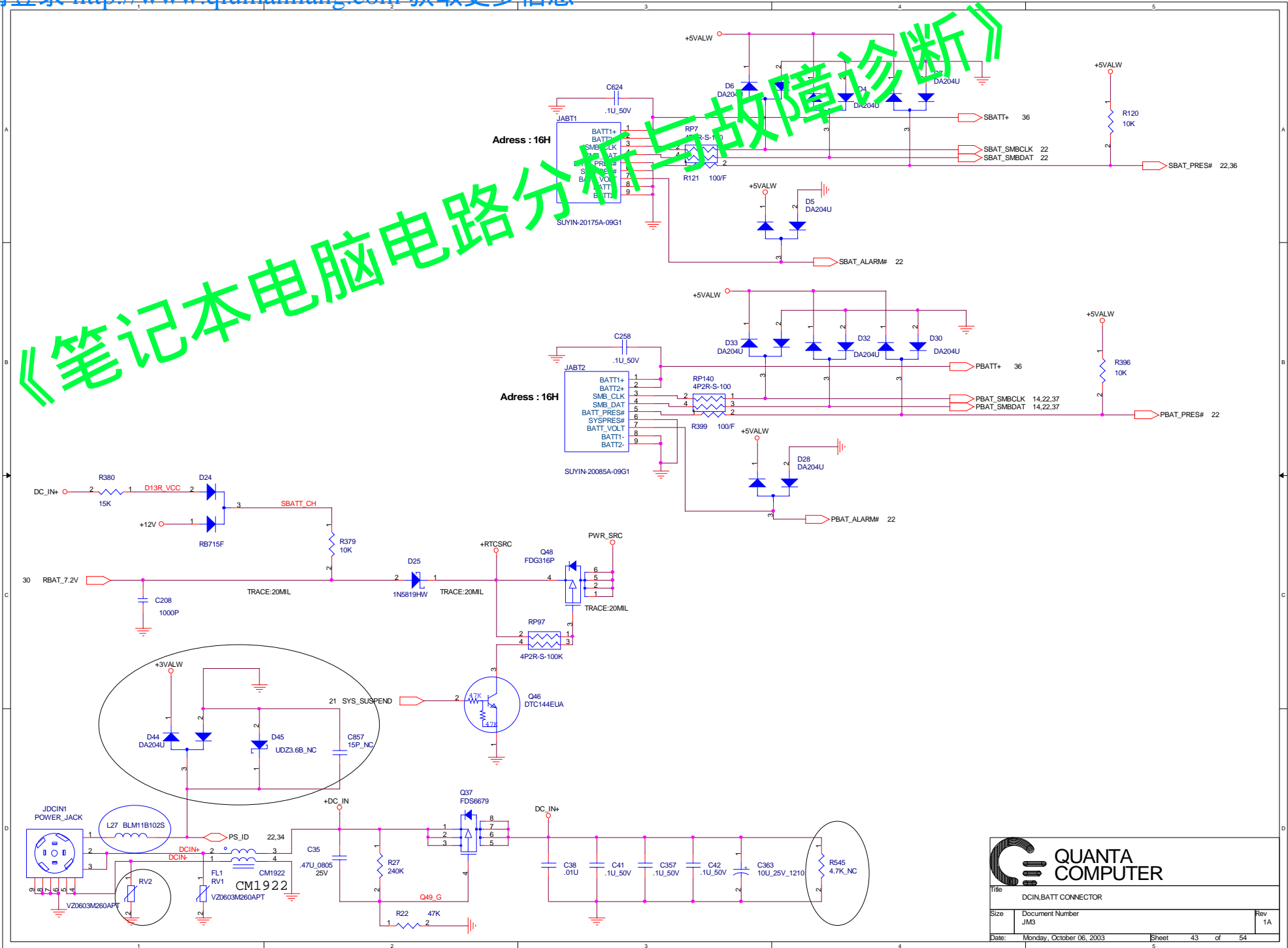

Title: DCIN,BATT CONNECTOR	
Size: JMS	Document Number: JMS
Date: Monday, October 06, 2003	Sheet: 43 of 54
Rev: 1A	

《笔记本电脑电路分析与故障诊断》

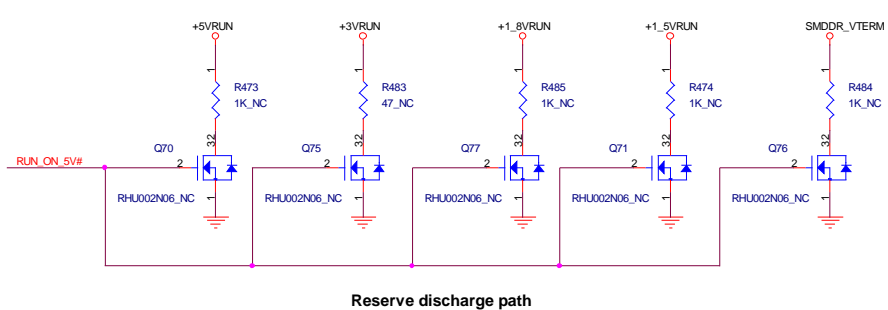
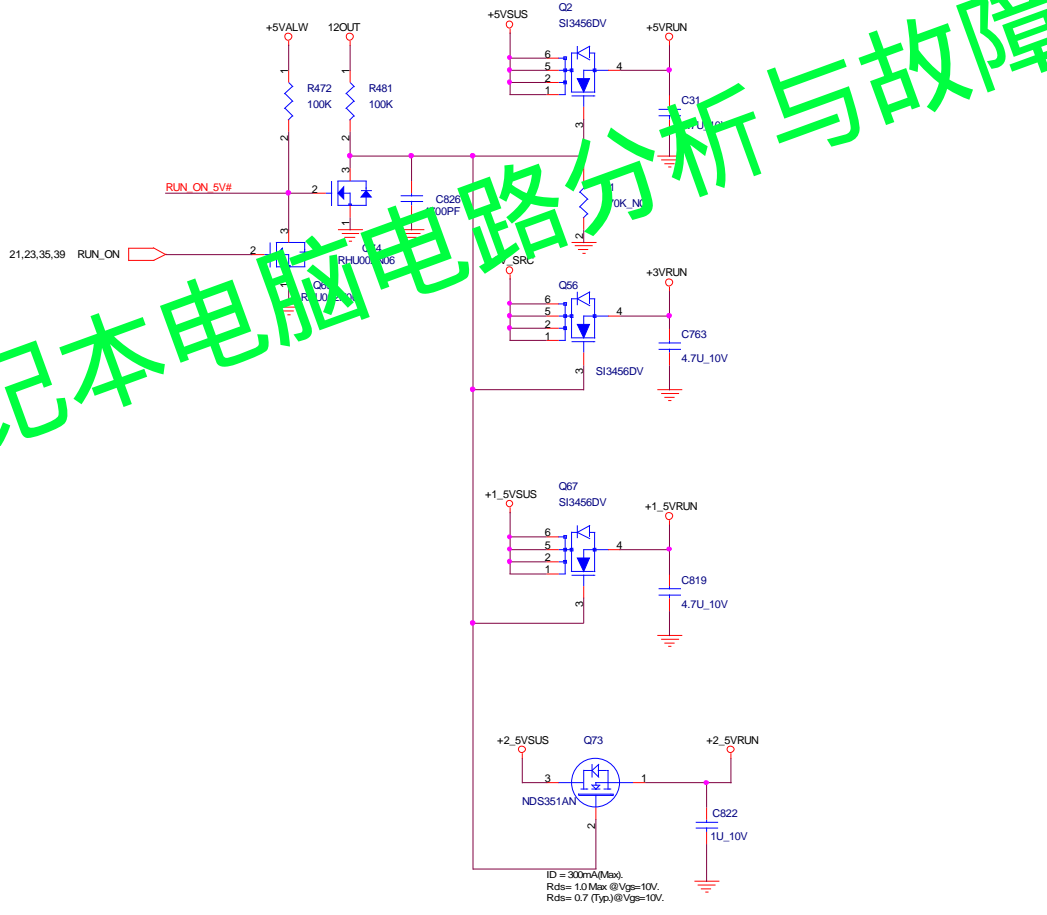

Title		RUN POWER SW	
Size	Document Number	Rev	
	JMS	2B	
Date:	Monday, October 06, 2003	Sheet	44 of 54