



# LaserWriter Pro 600/630

---

LaserWriter Pro 600, LaserWriter Pro 630





## Basics

---

LaserWriter Pro 600/630





## Product Information

The printers covered in this manual are the LaserWriter Pro 600 and LaserWriter Pro 630. Except for the I/O boards, all parts are identical between the two models.

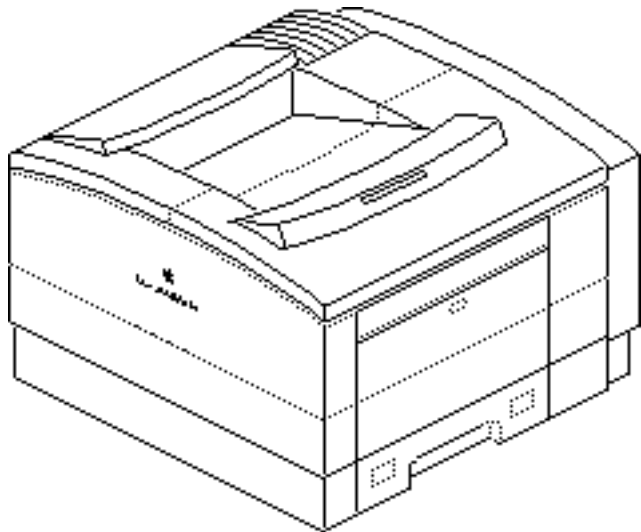



**Note:** Refer to the following chapters in the Envelope Feeder LW Pro-LW 16/6 and Sheet Feeder LW Pro-LW 16/6 manuals for additional information on feeder options.

- Take-Apart
- Additional Procedures
- Adjustments
- Illustrated Parts





# LaserWriter Utility

**Note:** Refer to the user's guide for complete information regarding LaserWriter Utility. This application gives you software control over the LaserWriter Pro that is essential to its operation. Some of features of LaserWriter Utility include:

- Naming the printer
- Setting default printer resolution
- Turning on FinePrint
- Turning on PhotoGrade (if available)
- Setting default paper-handling options
- Setting print density
- Setting communication protocols
- Printing configuration page
- Turning off the startup test page

**Note:** You must use LaserWriter Utility version 7.4 or





later. You can override some default settings through the Print dialog (LaserWriter driver version 7.2 or later).



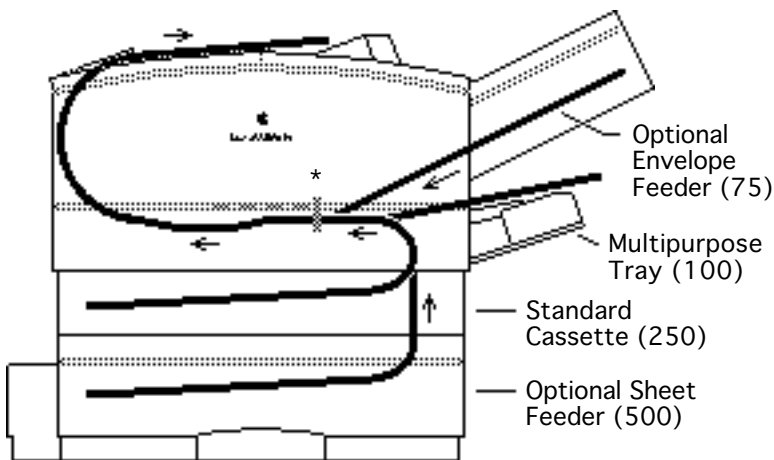

## Paper Path

There are four paper sources and one output tray in a complete system. The number in parenthesis is the capacity of the paper source.

**Note:** The asterisk at the point where the paper paths meet denotes a synchronization pause. See PS602 in “Sensing System Theory” in this chapter.



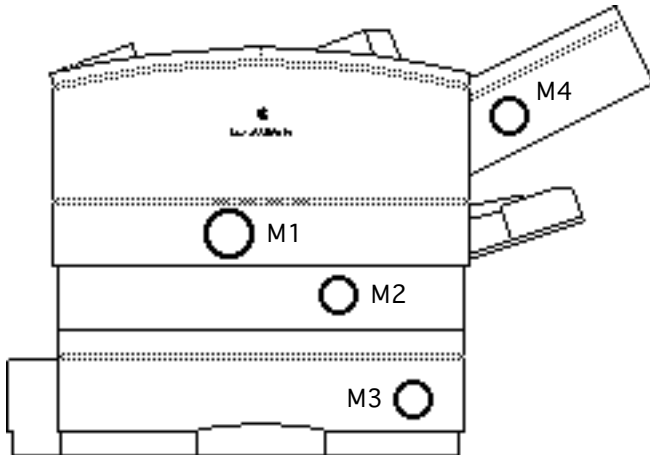

## Mechanical Drive Theory

There are four motors and four separate drive trains in a complete system. Two are in the printer engine and one is in each of the optional feeders.

- M1 Main Motor
- M2 Pickup Block Motor
- M3 Sheet Feeder Motor
- M4 Envelope Feeder Motor





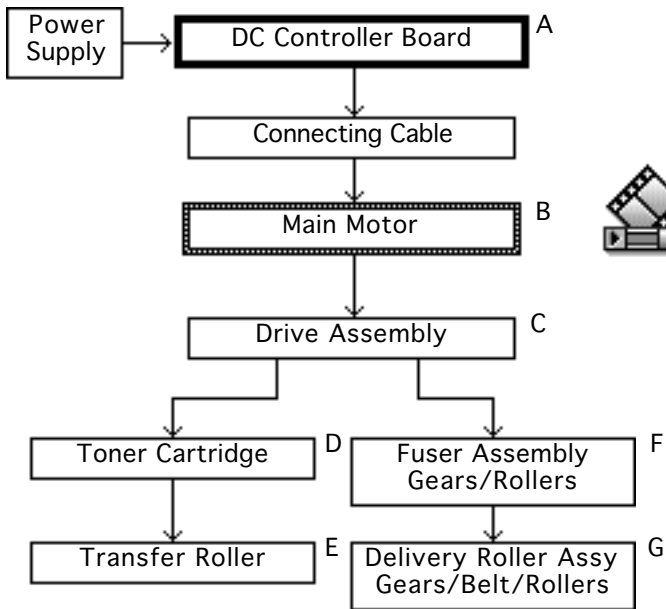

## M1 Main Motor Drive

The main motor powers the system that transports paper from the toner cartridge to the delivery tray on top of the printer.

**Note:** The letters next to the boxes correspond to the labels in the mechanical drive animations that are available on the CD.



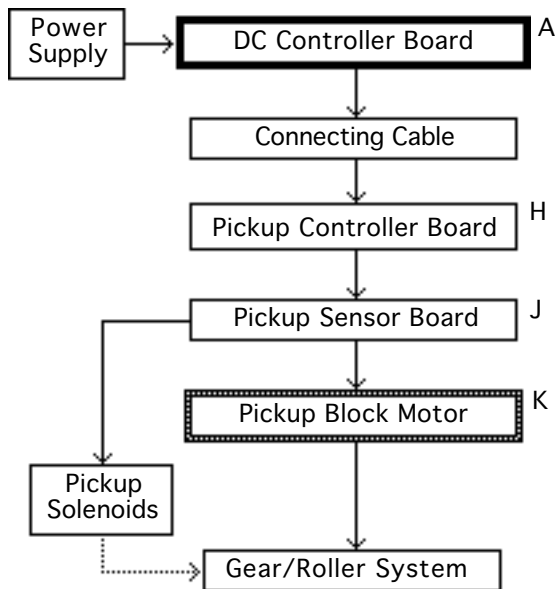

## M2 Pickup Block Motor Drive

The pickup block motor powers the system that transports paper into the engine, through the pickup block, and up to the toner cartridge.

**Note:** The DC controller board does not connect directly to the pickup block motor. Make sure to troubleshoot the three intermediate blocks if there is a failure in pickup block drive.





## M3 Sheet Feeder Motor Drive

The sheet feeder motor powers the system that transports paper from the 500-sheet cassette upward into the printer engine.

**Note:** Once the paper reaches the lower feed roller in the pickup block, engine components supply mechanical drive.

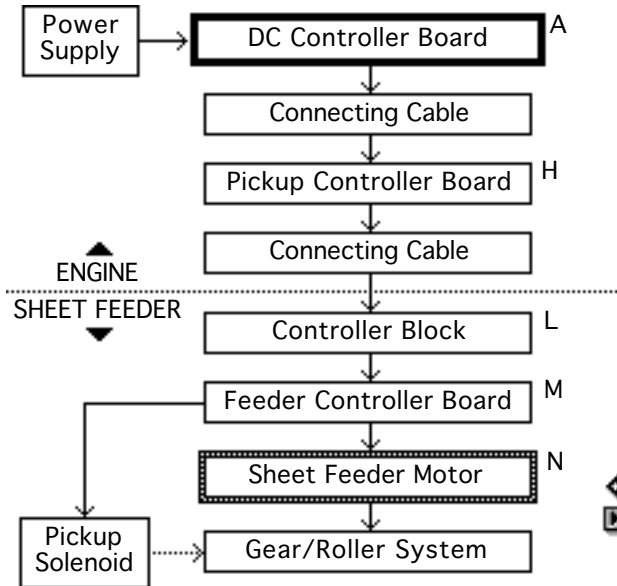

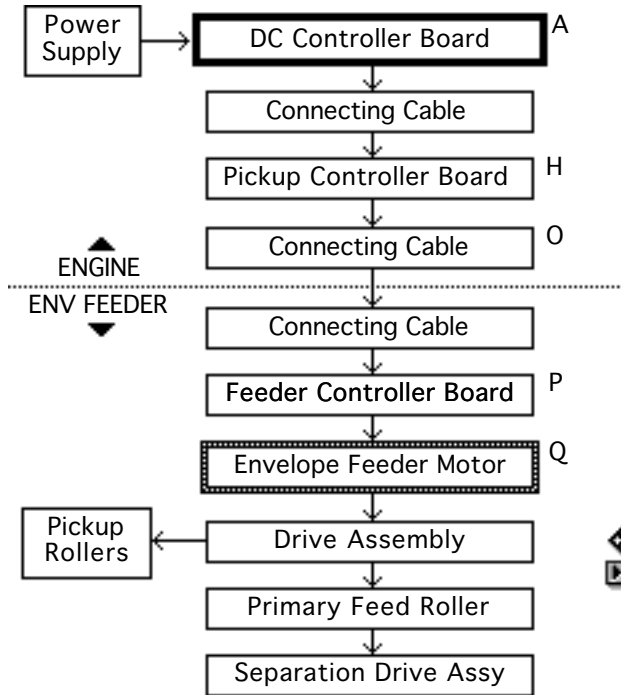

## M4 Envelope Feeder Motor Drive

The envelope feeder motor powers the system that separates envelopes and feeds them into the printer engine.

**Note:** Once an envelope reaches the upper feed rollers in the pickup block, engine components supply mechanical drive.





# Sensing System Theory

There are six paper sensors, one dual-purpose sensor, and seven sensing switches in a LaserWriter Pro 600/630 PS system:

## Paper Sensors

- PS601: Cassette Paper Sensor
- PS602: Registration Paper Sensor
- PS701: Multipurpose Paper-End Sensor
- PS702: Multipurpose Paper-Present Sensor
- PS851: Sheet Feeder Paper-Present Sensor
- PS931: Envelope Paper-Present Sensor
- PS201: Delivery/Interlock Sensor

## Sensing Switches

- SW601: Top Cover Interlock Switch
- SW603: Upper Cassette Size Sensing Switch





- •SW604: Upper Cassette Size Sensing Switch
- •SW605: Upper Cassette Size Sensing Switch
- •SW851: Lower Cassette Size Sensing Switch
- •SW852: Lower Cassette Size Sensing Switch
- •SW853: Lower Cassette Size Sensing Switch



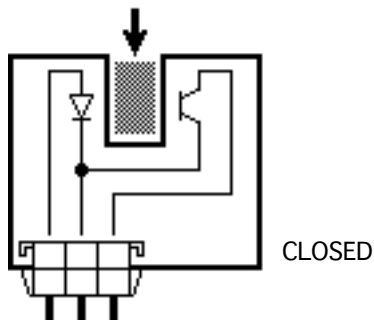
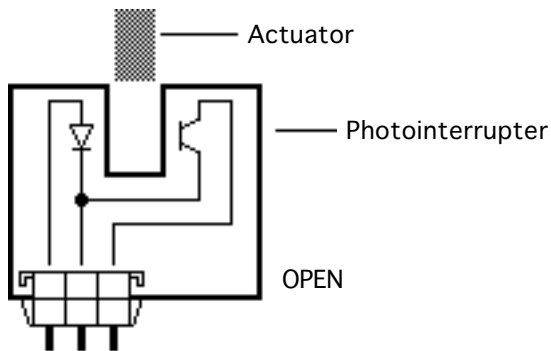

## Paper Sensors

Paper sensors consist of an actuator, a U-shaped photo interrupter, and circuitry. Sensors are tripped as the actuator swings against movement of paper and blocks the gap of the U. An actuator can be passive (governed by gravity) or spring-loaded.

**Note:** Sensor failure can be either mechanical or electrical. When troubleshooting sensors, first confirm that the arm





or lever moves freely without snagging, that any springs are applying correct resistance, and that the actuator is not broken. Then check that all cable connections are secure. If you have eliminated mechanical issues, proceed with electrical troubleshooting.







## PS601

Cassette Paper Sensor

Actuator: A passive lever in the sensor holder assembly is tripped by insertion of a loaded cassette tray.

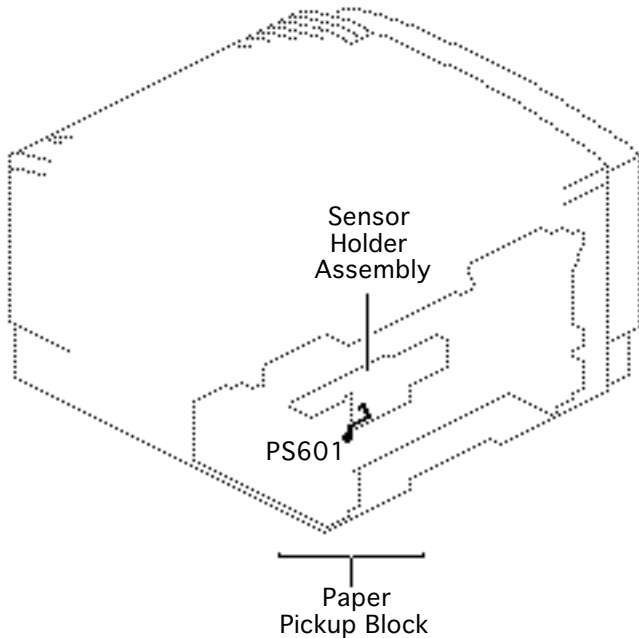



## PS602

### Registration Paper Sensor

Actuator: A spring-loaded lever in the sensor holder assembly is tripped by arriving paper.

All paper stops at PS602 and waits for proper synchronization with drum rotation and mechanical drive.

**Note:** If paper does not reach sensor PS602 within the prescribed time after the pickup signal is issued, a

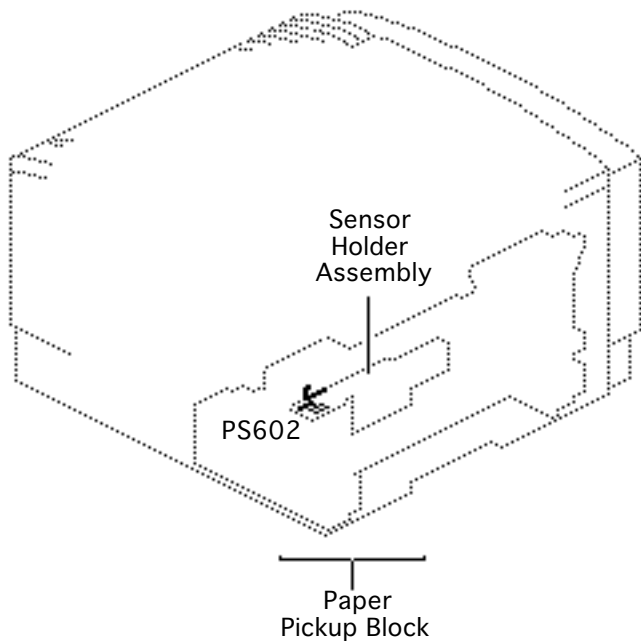



pickup unit delay jam exists and the controller stops printing.

If paper reaches the sensor but does not clear it within the correct time, a pickup unit stationary jam exists. The time allowed for paper to clear is a function of paper size, which is detected by PS701 (for manually fed paper) and by sensing switches (for cassette-fed paper).





## PS702

### Multipurpose Paper-Present Sensor

Actuator: A spring-loaded lever in the paper pickup block is tripped by the leading edge of paper as it is loaded in the multipurpose tray.

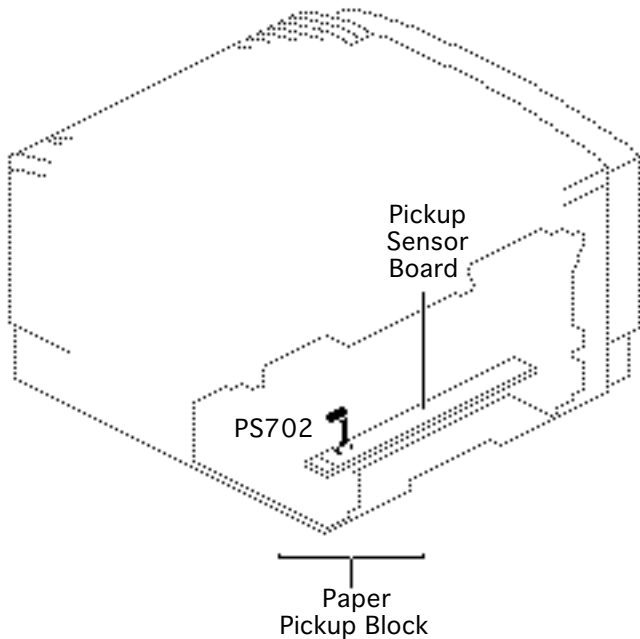

**PS701**Multipurpose Paper-End  
Sensor

Actuator: A passive lever in the paper pickup block is tripped by the trailing edge of paper leaving the multipurpose tray.

Sensor PS701 detects the size of paper fed from the multipurpose tray.

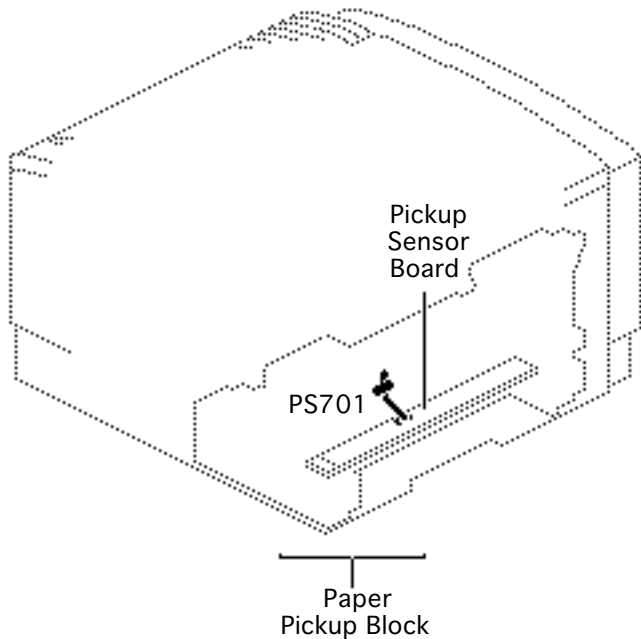



## PS201

### Delivery/Interlock Sensor

Actuator: A plastic tab on the fuser door and a sensing lever in the fuser assembly act independently to trip a photo interrupter.

PS201 detects two things: paper exiting the fuser and closure of the fuser door.

**Note:** If paper does not reach sensor PS201 within 5.2 seconds after it reached registration sensor J602, a delivery unit delay jam

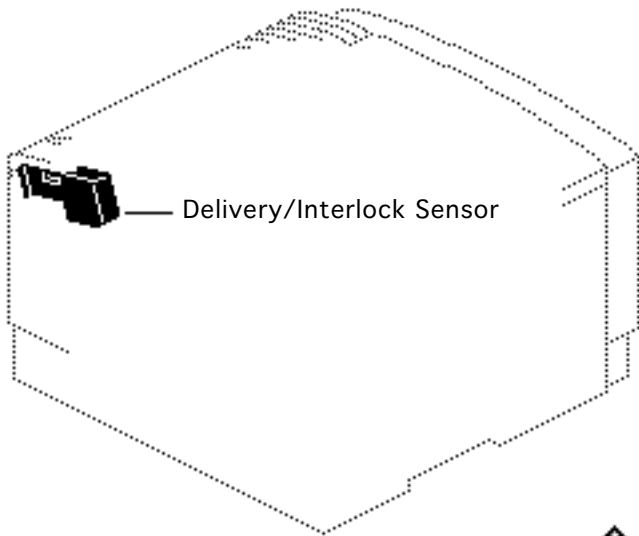



exists and the controller stops printing.

If paper reaches the sensor but does not clear it within the correct time, a delivery unit stationary jam exists. The time allowed for paper to clear is a function of paper size, which is detected by PS701 (for manually fed paper) and by sensing switches (for cassette-fed paper).





## PS851

Sheet Feeder Paper-Present Sensor

Actuator: A passive lever in the controller block is tripped by insertion of a loaded cassette tray.

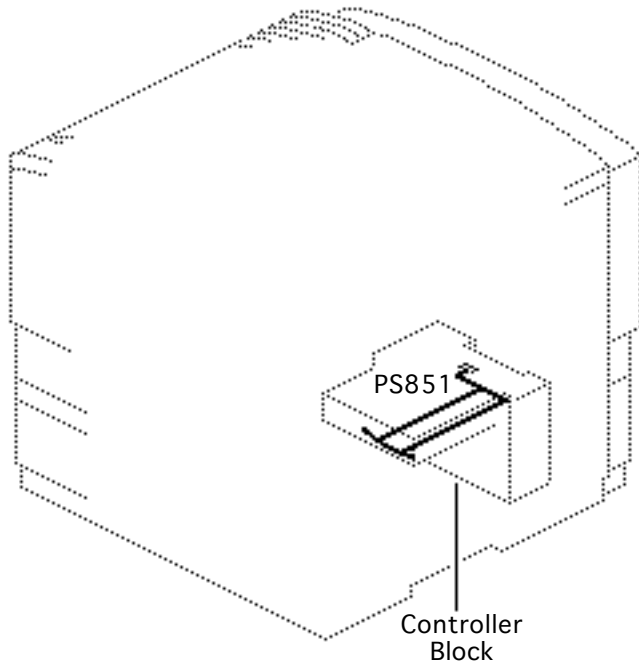





## PS931

Envelope Feeder Paper-Present Sensor

Actuator: A spring-loaded lever is tripped by placement of envelopes into the feeder.

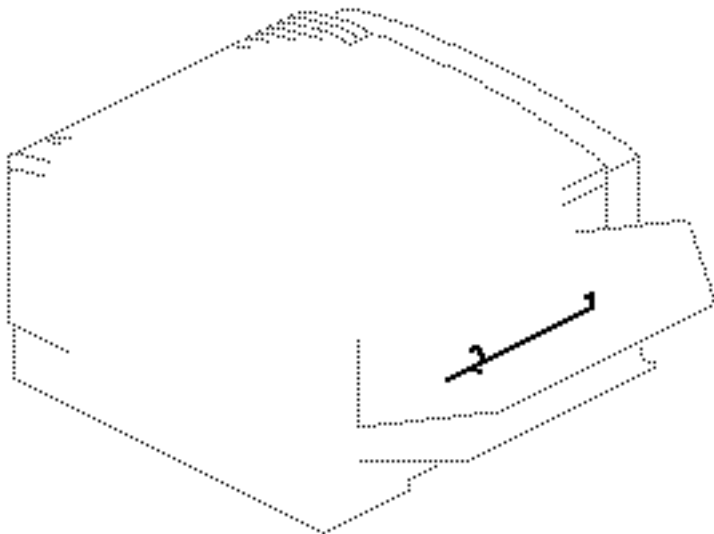

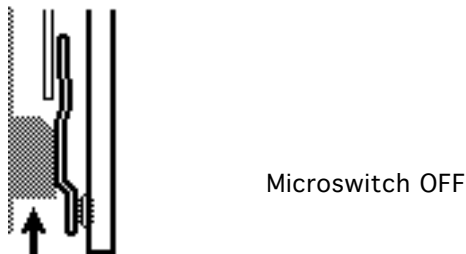
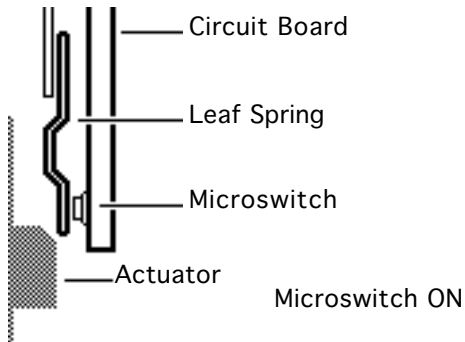

## Sensing Switches

Sensing switches attach to a circuit board and do not use photo interrupters.

Switches are actuated by leaf springs that press inward as you insert a cassette tray or close the top cover.

Failure in sensing switches can be either mechanical or electrical. When troubleshooting switches, first confirm that the actuator has not broken off and then confirm that the leaf springs are not bent or





misshapen. You should be able to press the leaf spring with your finger and hear the clicking of the microswitch.

If you have eliminated mechanical issues, proceed with electrical troubleshooting.





## SW601

### Top Cover Interlock Switch

Actuator: A tab on the top cover actuates a leaf spring and pin, which press the microswitch on the pickup controller board. See “Troubleshooting Tips” in Troubleshooting for information on defeating the top cover interlock switch.

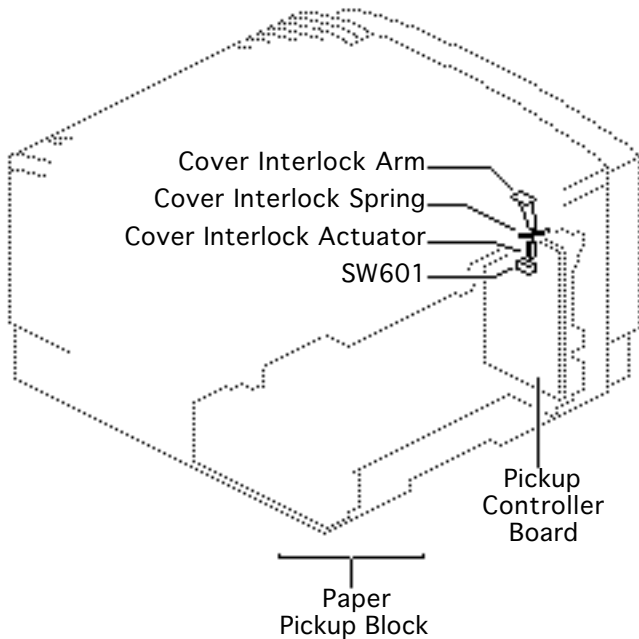



Cassette	SW603	SW604	SW605
(None)	OFF	OFF	OFF
Legal	ON	ON	OFF
Letter	ON	OFF	ON
A4	OFF	OFF	ON
Executive	OFF	ON	ON
B5	OFF	ON	OFF

Pickup  
Controller  
Board

SW603  
SW604  
SW605

Paper  
Pickup  
Block

## SW603/4/5

### Cassette Size Sensing Switches (Upper)

Actuator: Plastic tabs on the side of the cassette trays actuate leaf springs, which press microswitches on the pickup controller board. The tab/switch configurations are as shown.

**Note:** See the next page for a note regarding the 250-sheet universal cassette.





## SW851/2/3

### Cassette Size Sensing Switches (Lower)

Actuator: Plastic tabs on the side of a cassette tray actuate leaf springs, which press microswitches on the sheet feeder controller board.

**Note:** The sheet feeder uses a 500-sheet universal cassette. As with the upper 250-sheet universal cassette, the tabs are set manually by adjusting a selection dial on the cassette.

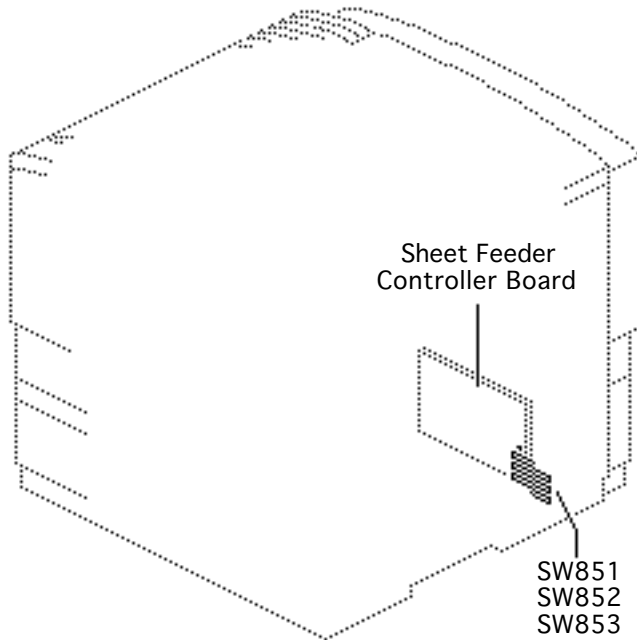



When you are troubleshooting, be aware that human error can be a factor in paper-size sensing for these universal cassettes.





## Hard Drives

**Note:** Refer to the user's guide for initialization requirements for previously used hard drives.

### External Hard Drives

You can connect up to seven external hard drives to the LaserWriter Pro 630. You cannot connect a SCSI device to the LaserWriter Pro 600. The SCSI ID assigned to the LaserWriter Pro 630 is 6. Any SCSI device connected to the printer must have a different number.

**Caution:** The push button switch is for configuring communication parameters. It is not a SCSI ID switch.







## **Internal Hard Drives**

Internal hard drives are currently available only through third-parties. They should come with mounting bracket, data cable, and documentation.

The data cable for an internal hard drive connects into J1 on the LaserWriter Pro 630 I/O board. Connector J1 is a 40 pin connector with non-standard 2 mm pin spacing.





## Test/Configuration Pages

There are three special pages that an operational LaserWriter Pro 600/630 can print. Each indicates information that can isolate problems and/or identify the configuration of the printer.

### Startup Test Page

The printer generates a startup test page 2-3 minutes after you switch on the printer. Successful printing of this page indicates that the I/O board is operational.

**Note:** The startup test page may not print due to software disabling (see “LaserWriter Utility” in Basics).





### Service Test Page

The printer generates a service test page when you press the service test page button. Successful printing of this page indicates that the printer engine is operational.

### Configuration Page

The printer generates a configuration page when you issue the "Print Configuration Page" command with LaserWriter Utility.





# Startup Test Page

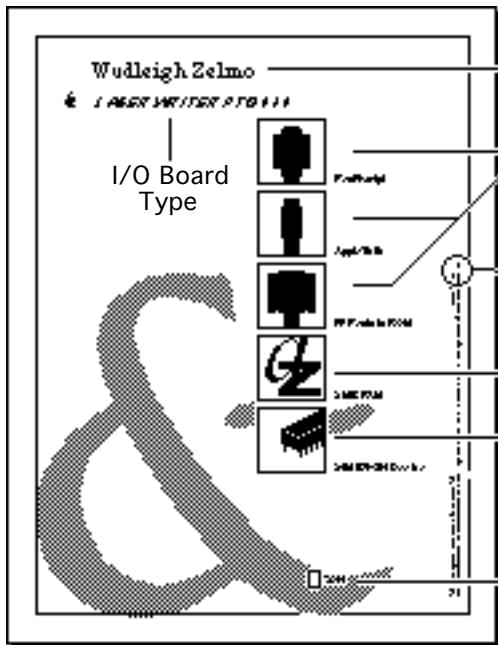

Printer Name

Communication parameters and printer control language selected for an individual printer port

ROM version

Installed RAM

Number of pages the I/O board has produced

Other startup icons



FinePrint enabled



PhotoGrade enabled



Hard Drive on-line



600 dpi enabled



Optional feeders installed





## Service Test Page

To access the service test page button, open the multipurpose tray. The button is located in the upper right corner of the opening. The button is small and difficult to see against the black plastic. Use a paper clip or similar tool to press the button.



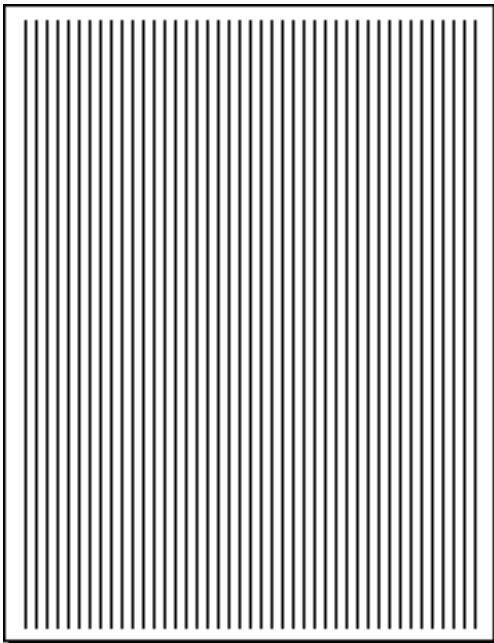

The service test page pattern is a series of vertical lines that cover the imageable area of the page.



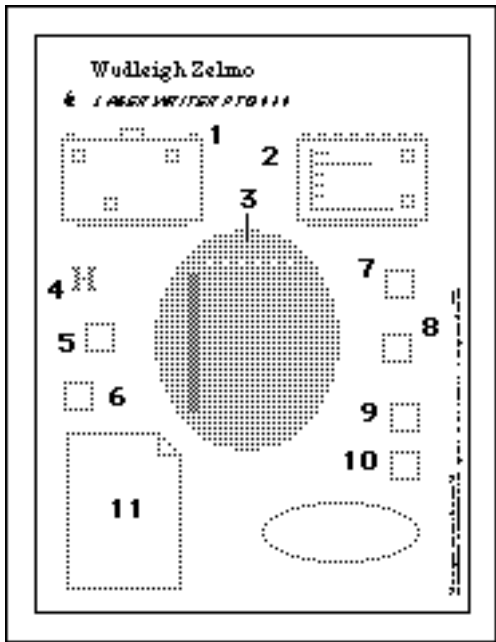

## Configuration Page

This page provides the following information to the service technician.

- Network address settings (1)
- Amount and allocation of RAM memory and readout of EEPROM integrity (2)
- Switch configurations (3)
- HP LaserJet® emulator version (4)
- Startup page setting (on or off) (5)
- LaserWriter serial number (6)





- Timeout settings (7)
- System administrator password (8)
- SCSI ID (LaserWriter Pro 630 only) (9)
- Halftone screen settings (10)
- Default margin offsets (11)

If possible, always print a configuration page before calling Apple Technical Assistance Center.







# Configuration Switch

The communication switch on the I/O board determines the communication configuration for all the available ports.

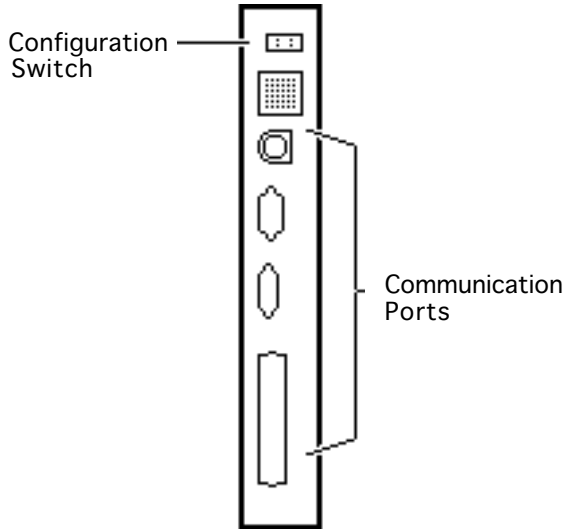



# LaserWriter Safety

## Unplug Printer

LaserWriter printers operate at high voltages. To prevent serious injury, always switch off the printer and unplug the AC power cord before servicing the printer.

## Laser Beam Safety

Never disconnect the beam-detect cabling or laser shutter when the printer is switched on. Also be careful not to place screwdrivers or other shiny objects in the path of the laser beam. The reflected laser beam, though invisible, can permanently damage your eyes.

Never remove the cover of a laser/scanner assembly, whether the printer is powered on or not.

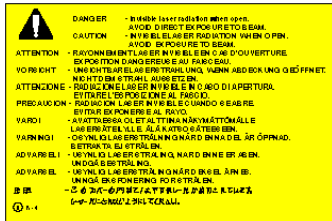



## Fuser Heat

The fuser assembly rollers become very hot during printer operation. Before servicing the fuser assembly, switch off the printer for at least 5 minutes to allow the fuser assembly roller to cool.

## Toner Safety

Toner is a nontoxic substance composed of plastic, iron, and a small amount of pigment. Clean skin and clothing by removing as much toner as possible with a dry tissue, then washing with cold water. Hot water causes toner to jell and permanently fuse into clothing. Toner attacks vinyl materials, so avoid contact with vinyl.

## Weight

LaserWriter printers are heavy. When lifting or moving the printer, be careful not to strain your back.





## Specifications

---

LaserWriter Pro 600/630





## Engine

<b>Engine</b>	Canon LBP-B270 engine
<b>Printing Method</b>	Electrophotography using single-component microfine toner
<b>Optical System</b>	Semiconductor laser and a rotating six-faced prism scanning mirror
<b>Resolution</b>	LaserWriter Pro 600: 600 dpi* LaserWriter Pro 630: 600 dpi (300 dpi when PhotoGrade is enabled)  <b>Note:</b> The LaserWriter Pro 600 requires 8 MB of RAM in order to print in PhotoGrade or to print at 600 dpi.



**Dimensions**

Height: 11.61 in. (295 mm)

Width: 16.69 in. (424 mm)

Depth: 16.37 in. (416 mm)

**Clearance Required**

50.4" x 24.25" x 19.75" high (1282 x 616 x 501 mm)

**Weight**

Printer with cassette: 40.7 lb. (18.5 kg):

Toner cartridge: 3.3 lb. (1.5 kg)

**Operating  
Environment**

Temperature: 50-90.5° F (10-32.5° C)

Humidity: 20-80% relative humidity

Atmospheric Pressure: 570-760 mmHg

**Power Consumption**

Approximately 0.66 kW at 71° F (20° C)





**Printing Speed**

8 pages per minute (letter or A4)  
6 envelopes per minute (optional envelope feeder)

**Duty Cycle**

No limit in pages per month

**Consumables  
Service Life**

Pickup Rollers: 200,000 pages  
Separation Pad: 200,000 pages  
Fuser Assembly: 200,000 pages  
Transfer Roller: 200,000 pages  
Exhaust Fan: 25,000 hours

**Note:** Replace the multipurpose pickup roller and separation pad together. The separation pad is contained in the multipurpose tray guide assembly.





**Macintosh  
Requirement**

System Software 6.0.5 or later

**Printable Area (in  
inches)**

US Letter: 8.11 by 10.79

US Legal: 8.11 by 13.79

A4: 7.89 by 11.44

B5: 6.72 by 9.81







## I/O Board

**CPU** Motorola 68030 (25 MHz)

**RAM** LaserWriter Pro 600: 8 MB, expandable to 32 MB \*  
LaserWriter Pro 630: 8 MB, expandable to 32 MB

**Note:** In early 1993 some LaserWriter Pro 600's shipped with 4 MB of RAM and a free upgrade kit that dealers were instructed to install. No LaserWriter Pro in the marketplace was to have been sold with less than 8 MB of RAM.

**ROM** 2 MB standard

**Expansion** 40-pin processor direct slot (PDS) provided





## **Pinouts**

LaserWriter Pro 600:  
LocalTalk, RS-232, Centronics  
LaserWriter Pro 630:  
LocalTalk, RS-232, Centronics, SCSI, Ethernet

## **Settings**

Use configuration switch or LaserWriter Utility to set communication protocols. The setting of the configuration switch affects the configuration of all the pinouts. See the user's guide for switch settings.

## **Imaging Languages Supported**

QuickDraw, PostScript Level 2, and HP PCL 4





## Sheet Feeder

### Dimensions

Height: 5.19 in. (132 mm)

Width: 16.38 in. (416 mm)

Depth: 18.50 in. (470 mm)

### Weight

12.98 lb. (5.9 kg) with cassette

### Power Consumption

24 VDC

supplied by printer

PAGEBREAK





## Envelope Feeder

**Dimensions**

Height: 5.03 in. (127.8 mm)

Width: 12.04 in. (306.5 mm)

Depth: 11.53 in. (293 mm)

**Weight**

5.72 lb. (2.6 kg)

**Power Consumption**

24 VDC supplied by printer





## Paper

### **Input Sources and Capacities**

Standard cassette (250)  
Multipurpose tray (100)  
Lower cassette (500)  
Envelope feeder (75)

### **Output Source**

Face-down delivery tray

### **Paper Sizes**

Standard Cassette:  
A4, B5, legal, letter, or executive plain paper (16-24 lb.)  
Cassettes available: letter, A4, or universal

Multipurpose Tray  
Plain paper from 7.16 in. by 10.1 in. to 8.5 in. by 14 in. (16-32 lb.), envelopes, and fuser-compatible labels and film





### Lower Cassette

A4, B5, legal, letter, or executive plain paper (16-24 lb.)

Cassette available: universal

### Envelope Feeder

COM-10, DC, Monarch, C5, B5 (recommended envelope); from 3.54 in. by 7.44 in. to 7.0 in. by 10.0 in.

**Note:** Do not use envelopes with clasps, snaps, windows, or synthetic materials. Envelopes with peel-off adhesive strips or double sealable flaps must use fuser-compatible adhesive.





# Troubleshooting

LaserWriter Pro 600/630





## General

Troubleshooting contains quick-reference troubleshooting information for the LaserWriter 600/630. We encourage you to review and print out this chapter before troubleshooting a printer.

At the end of this chapter are troubleshooting flowcharts and tables. If a table name clearly addresses your problem, you can go directly to that table. If not, you should go to the flowchart associated with the version of the printer you are working on.







## Printer Diagnostic

To enable the printer diagnostic, switch off the printer, jumper pins 7 and 9 on the I/O board DB-9 connector, and switch on the printer. Under normal conditions, LEDs should flash during startup for about 15 seconds and then fix on the "diagnostic executing" configuration for about 2 minutes.

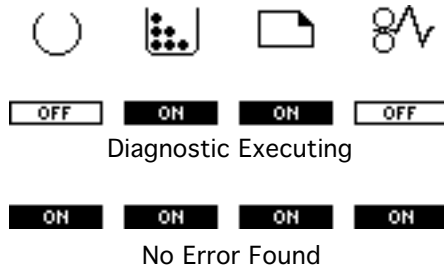
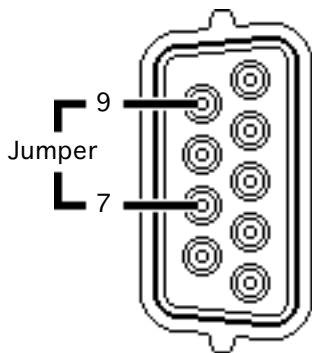



If no error is found, all LEDs come on and two pages print. See next page for "error-found" configurations.

**Note:** If the "diagnostic executing" LEDs persist longer than 3 minutes, an unknown error exists.

An "error-found" configuration could indicate a fault anywhere from the DC controller outward to the module or component. Go to the topic in Flowcharts that corresponds to the error.





ON  OFF  ON  OFF

I/O Board Error

ON  OFF  ON  ON

Fuser Assembly Error

ON  ON  OFF  OFF

Laser/Scanner Error

ON  ON  ON  OFF

Main Motor Error

OFF  OFF  OFF  ON

Fan Error

OFF  ON  OFF  OFF

ROM #1 Error

OFF  ON  OFF  ON

ROM #2 Error

ON  ON  OFF  ON

ROM #3 Error

OFF  ON  ON  ON

ROM #4 Error

ON  OFF  OFF  OFF

SIMM #1 Error

ON  OFF  OFF  ON

SIMM #2 Error





## Maintaining I/O Connectivity

Remove the printer interface cable and temporarily install a Quadra 900/950 floppy drive 20-pin cable between connectors A and B in the diagram on the next page. This cable has the extra length needed for the I/O shield to rest flat on the work surface.

**Note:** Do not disconnect power supply cable J15, the I/O-CPU cabling, or the AC power cable.





Maintaining I/O Connectivity

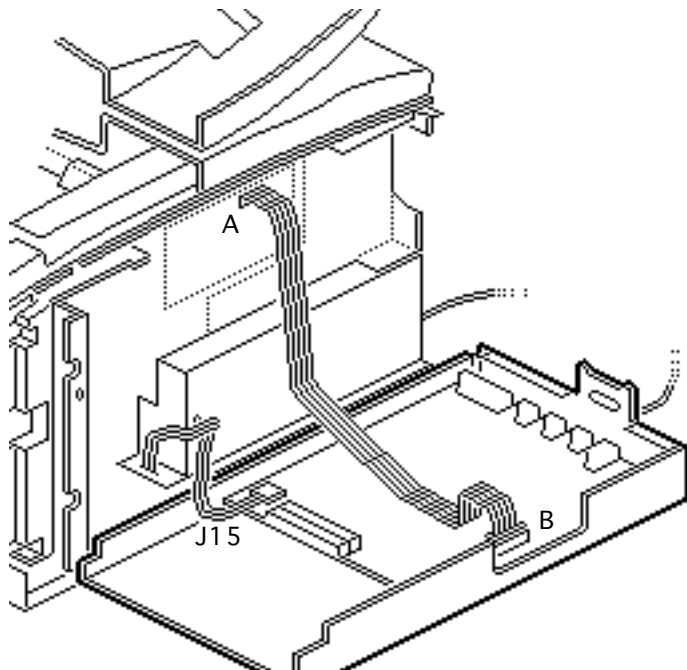



# Troubleshooting Tips

## Multimeter Probes

The connectors within the LaserWriter 600/630 are very small and require sharp needle-point probes to make good contact. Do not use probes that do not make proper contact. To see whether a set of probes works properly, test resistance at connector J210 on the DC controller board in the manner described below (the cable must be connected to the board).

Set your multimeter to resistance and insert the probes at pins 1 and 10. If the reading indicates continuity then the probes are making good contact. If the reading indicates infinite resistance, then the probes do not make contact and should not be used with this printer.





## Forcing a Feed Cycle

If you want to print from anything other than the standard 250-sheet cassette tray, you must be connected to a CPU and select the feed option that you want. It is not possible to print a service test page from any source other than the standard cassette.





## Interrupting a Print Cycle

Interrupting a print cycle and inspecting the photosensitive drum can help isolate the cause of print quality problems. If the image on the surface of the drum exhibits the same problem as the printed page, the fault is before the drum, probably in the imaging system.

If the image on the drum is OK, the fault is after the drum, probably in the fuser assembly, transfer block, or high-voltage power supply. To inspect the drum in this way, run a print and wait until the paper clears the synchronization pause at the registration paper sensor. Open the toner access door, remove the toner cartridge, and pull back the shield to inspect the drum.







## Maintaining Pickup Connectivity

To troubleshoot the paper pickup block, you must temporarily reconfigure the printer's paper path so that the pickup block is exposed. In this reconfigured state, you will be able to take voltage readings from the pickup controller board and observe paper feeding from the cassette.

**Note:** Since paper will jam due to the disruption of the paper path, you must disable the startup test page (see “Printer Utilities” in Basics) before turning the printer back on. Make sure to enable the startup test page before returning the printer to the customer.

To reconfigure the paper path, remove the pickup block, set it at an angle to the printer, and reconnect cables J601 and J603 at the leading edge of the pickup controller board. Insert the cassette tray into the pickup block. Press down the top cover interlock actuator and force the interlock switch closed by wedging in the





hooked end of the green cleaning brush. Reinstall the top cover and cover liner and close the lid.

If you want to test pickup from the multipurpose tray or the envelope feeder, you must maintain I/O connectivity (see previous topic). You cannot run a service test page from any source other than the standard 250-sheet cassette.

**Caution:** Do not let the pickup controller board brush up against the metal chassis when performing this procedure.





## Defeating the Top Cover Interlock

You may occasionally need to defeat the top cover interlock to simulate a “top cover shut” condition. To defeat this sensor, open the toner access cover and wedge a stiff, non-metallic insert into the interlock switch opening. Push the insert down to depress the interlock leaf spring.





## Defeating the Fuser Door Interlock

You may occasionally need to defeat the fuser door interlock to simulate a “fuser door shut” condition (for example if you wanted to observe paper as it exits the fuser rollers). To defeat this sensor, open the fuser access door and wedge the brush end of the green cleaning brush into the delivery/interlock sensor.

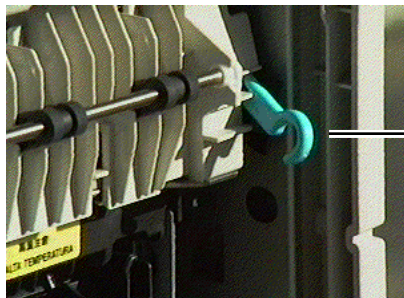

Green Cleaning Brush





**Caution:** Do not insert the brush too far into the sensor. After removing the brush, make sure that the delivery sensing arm moves freely and is not snagged.





## Sheet Feeder Bypass

You can visually troubleshoot a functioning stand-alone sheet feeder by bypassing connector J603 on the printer's pickup controller board.

Disable the startup test page, and remove the top cover, rear panel, and right corner panel from the printer. Disconnect J603 from the exposed edge of the pickup controller board and connect a spare sheet feeder interface cable (P/N 922-0219). Plug the opposite end of the interface cable into the sheet feeder receptacle.





## Observing Envelope Feed

You can visually inspect and/or take multimeter readings from a fully functioning envelope feeder. Remove the covers of the feeder and install it into the printer. The feeder will operate in normal fashion.

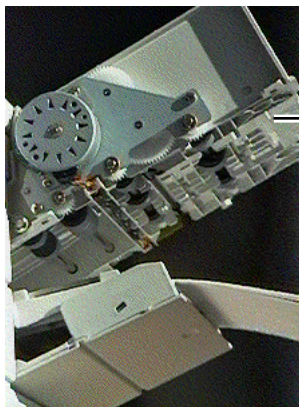

Envelope Feeder  
(without covers)





## **Drum Exposure**

Cover the toner cartridge when you remove it from the printer. Prolonged exposure to light can result in print quality problems.

If this has occurred, store the toner cartridge in a dark place. The drum will return to its normal condition after about 24 hours.







## Capacitor Discharge

When there is a failure of the fusing system, the DC controller board shuts off current to the fuser roller heater and charges capacitor C202 to prevent overheating. If there is a failure of the fusing system, you must turn the power off for about 10 minutes or manually discharge the capacitor before switching power back on.

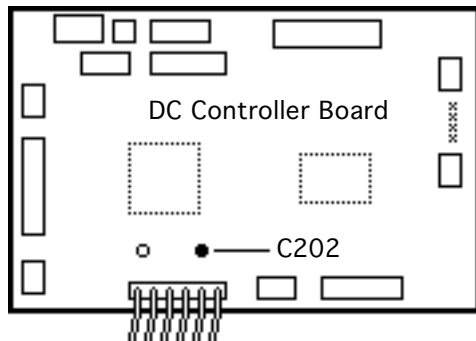



**Caution:** Be sure to switch off power and unplug the printer before performing this procedure.

To discharge capacitor C202, switch off the printer and remove the rear panel and I/O shield. Carefully jumper the two wires at the base of the capacitor using some kind of conductor.

**Note:** There are many different tools that can be used to discharge the capacitor: a flat blade screwdriver, paper clip, or aluminum foil doubled over. The tool illustrated is a length of lead solder. It has the advantage of being ductile and is less apt to damage the controller board.





Discharging  
Capacitor C202

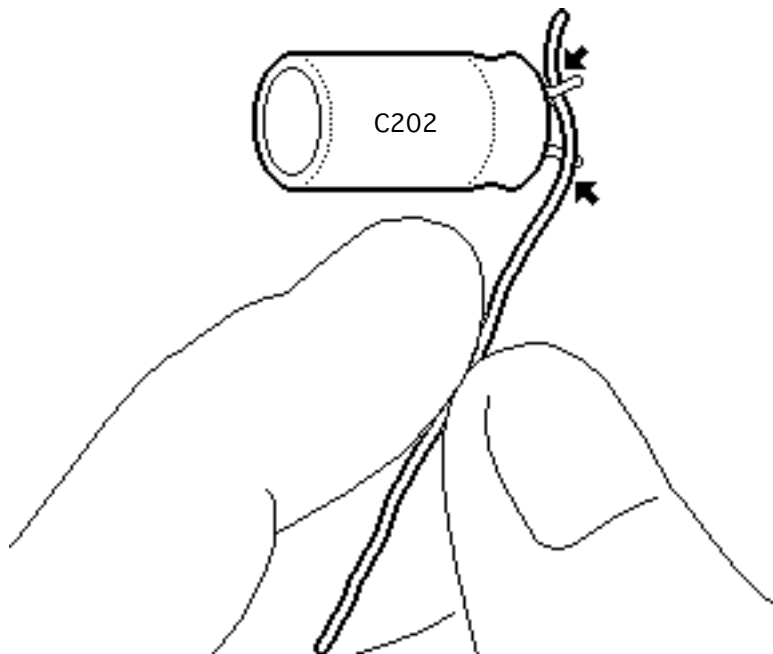



## Fuser Roller Modes

Two small levers at each end of the fuser set the fuser rollers into either print mode or jam-release mode. Apple ships the printer with the rollers in jam-release mode. Failure to set these levers into print mode will cause loose toner or smudging problems.

### Print Mode:

Engage the fuser rollers by setting the two levers in a "DOWN" position.

### Jam-Release Mode:

Disengage the rollers by setting the two levers in an "UP" position.



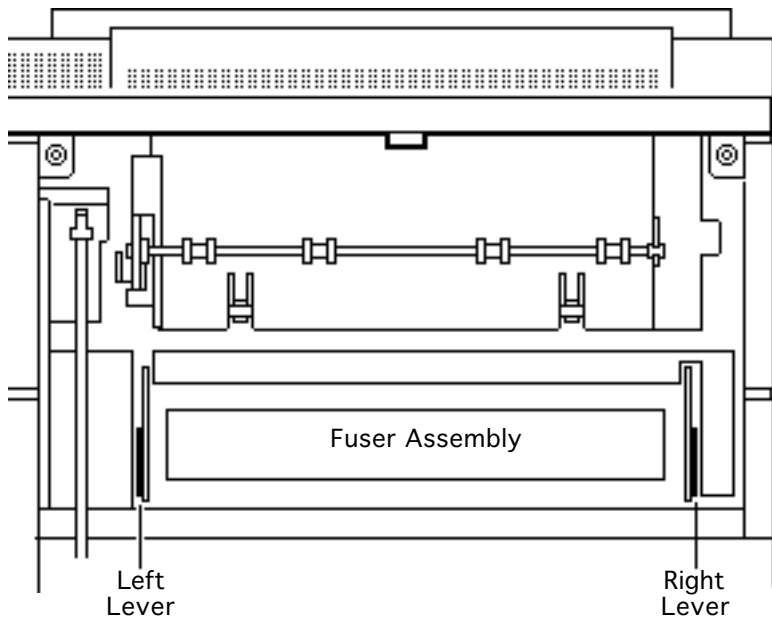



## Expansion Post Connectors

The LaserWriter 600/630 has several cable receptacles that are secured to the printer by finned post connectors. The fins expand when you insert the connector, but once the connector is installed it can be difficult to remove.

If you cannot remove these connectors with your fingers, try small bent-nose pliers, a 5 mm nut driver, or grip-rings forced around the post.

**Caution:** The cable receptacles are keyed. If you install them upside-down, they will not couple properly.



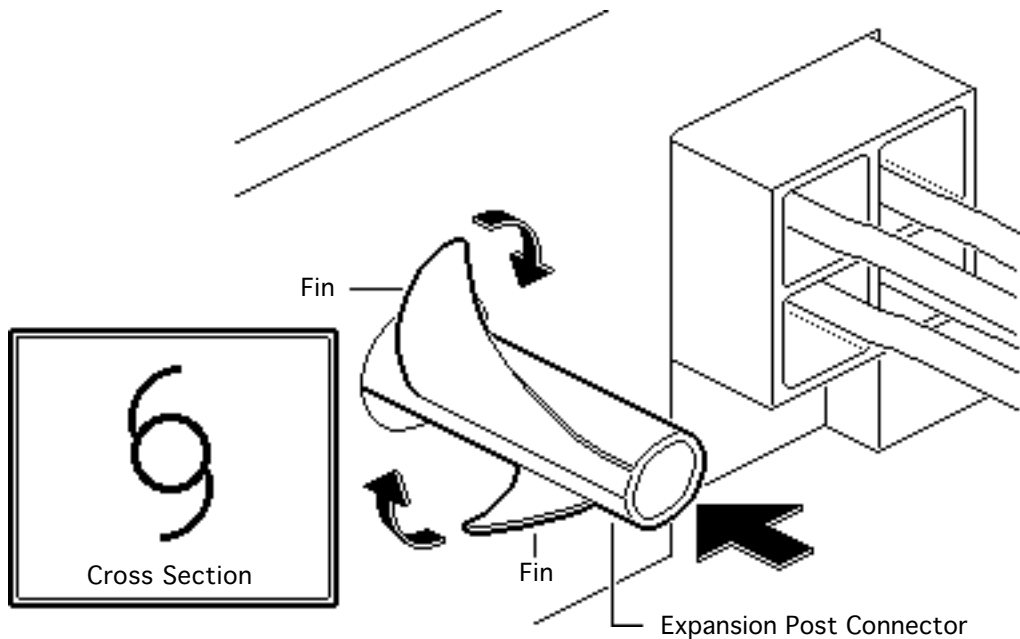



## Circuit Board Diagrams

On the following pages are diagrams of the circuit boards and high-voltage contacts listed below:

- LaserWriter Pro 600 I/O Board
- LaserWriter Pro 630 I/O Board
- DC Controller Board
- Pickup Controller Board
- Pickup Sensor Board
- High-Voltage Power Supply
- Envelope Feeder Controller Board
- Sheet Feeder Controller Board







LW Pro 600 I/O Board

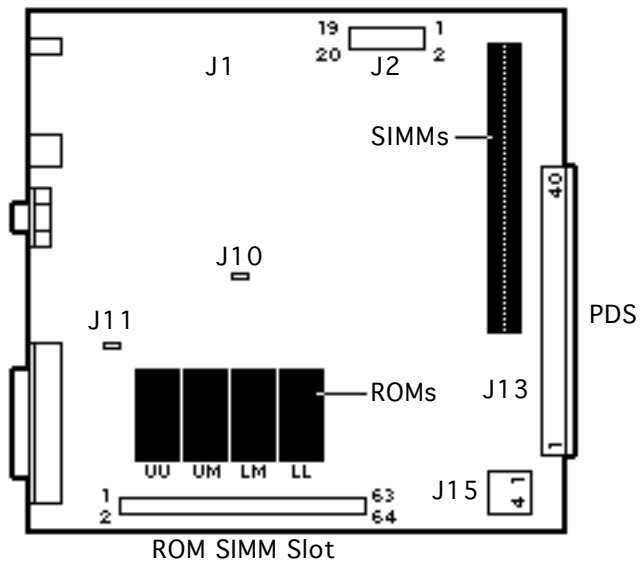
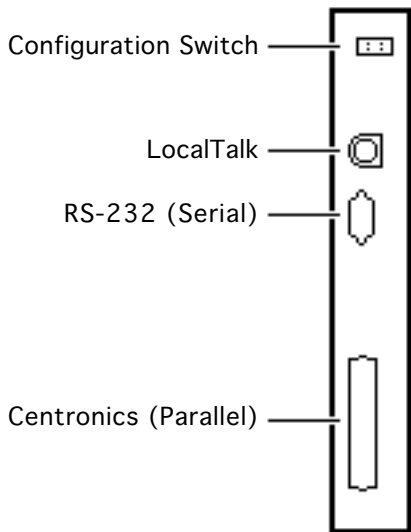



LW Pro 630 I/O Board

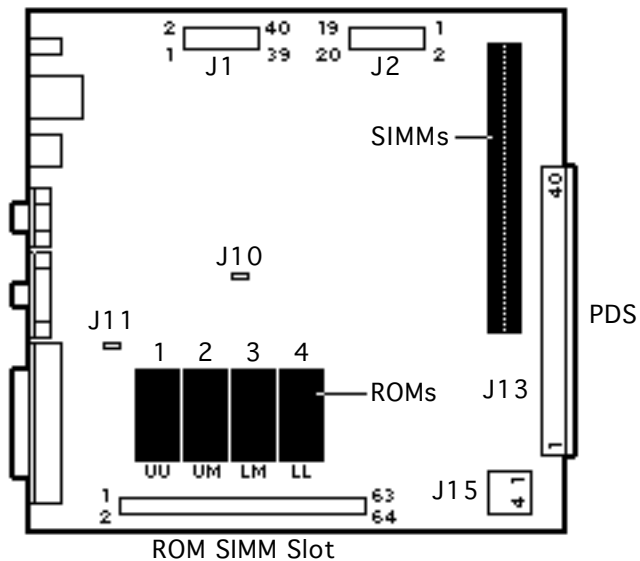
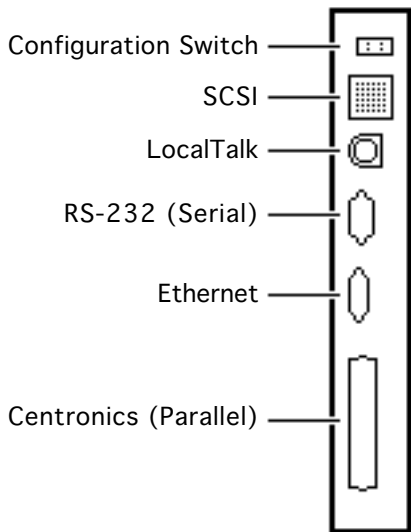



## DC Controller Board

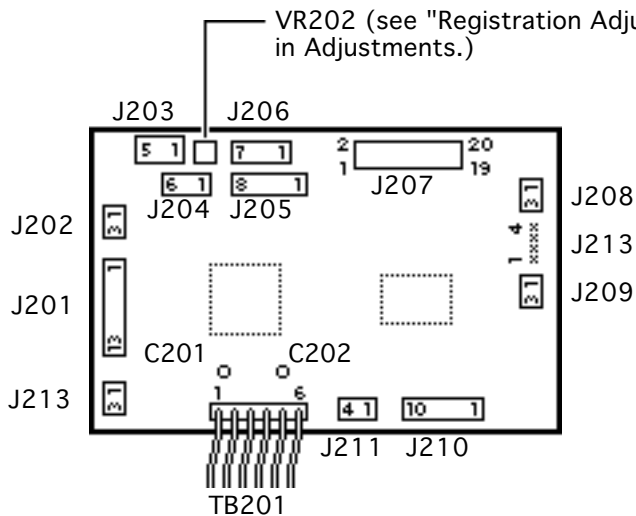

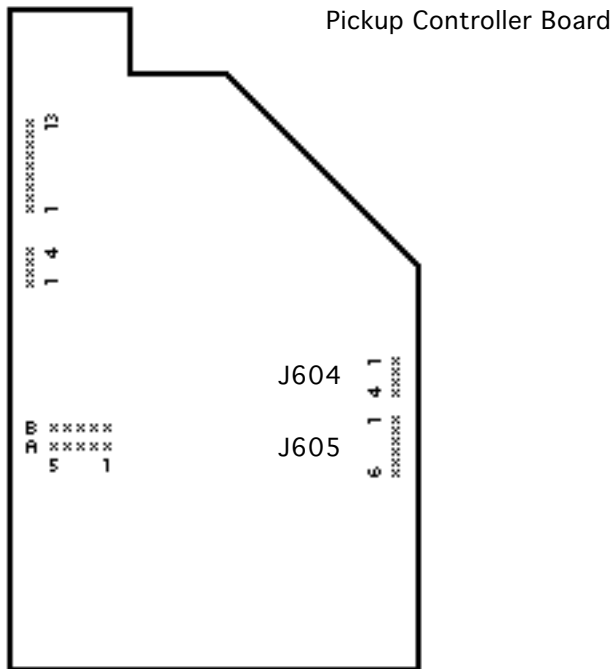
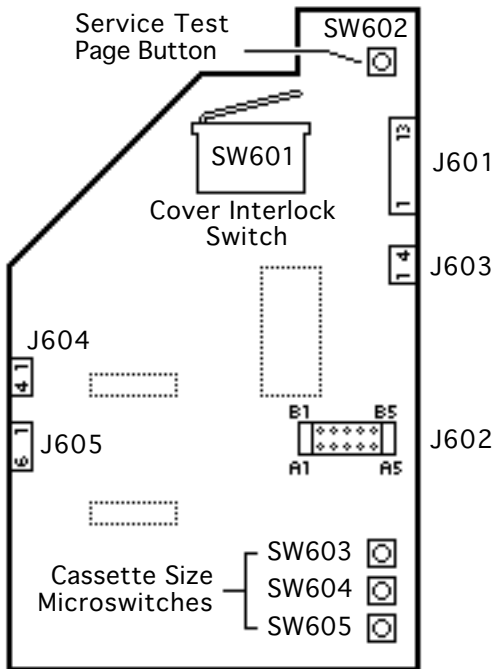



Pickup Sensor Board

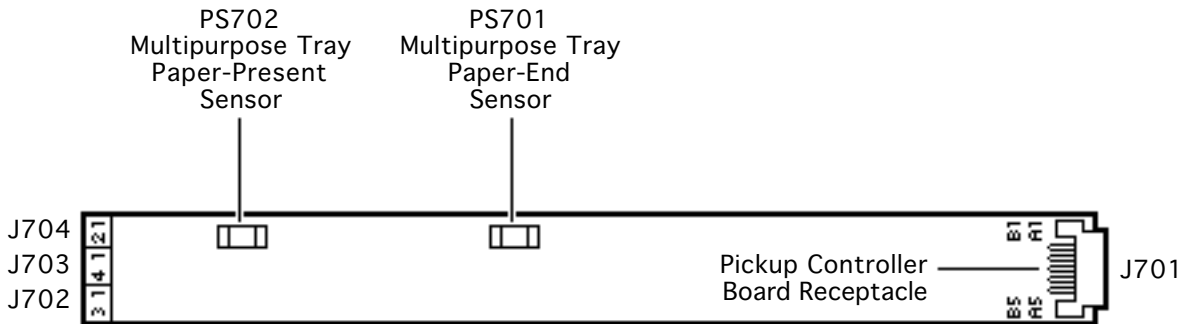



High-Voltage Power Supply

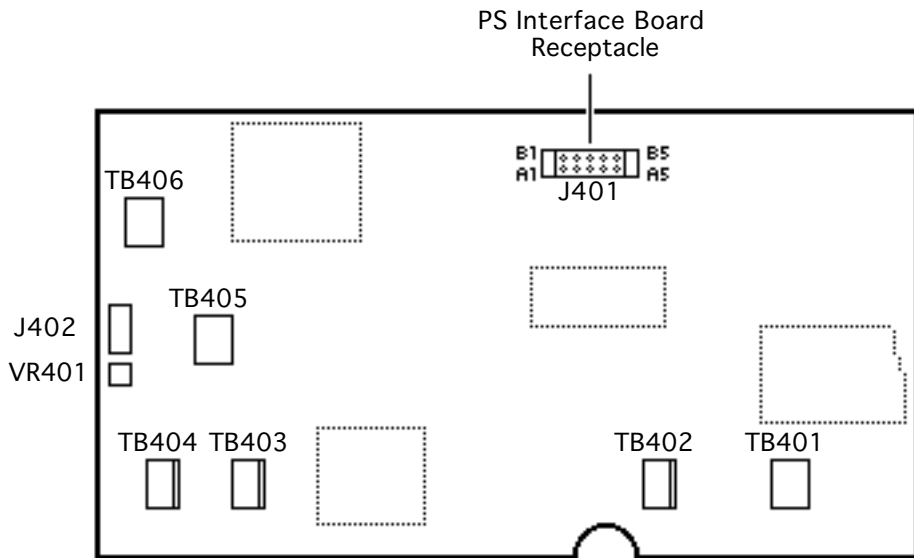



Envelope Feeder  
Controller Board

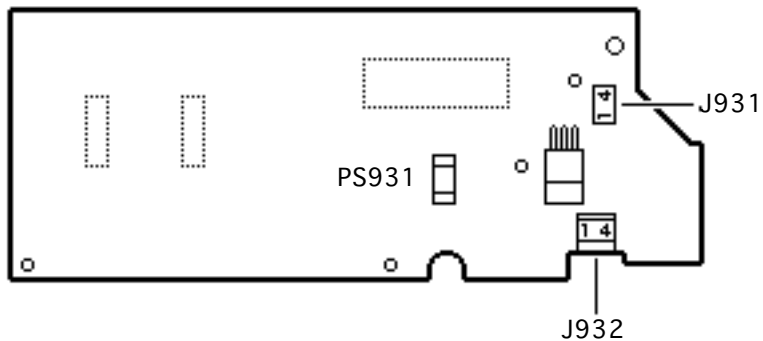



Sheet Feeder  
Controller Board

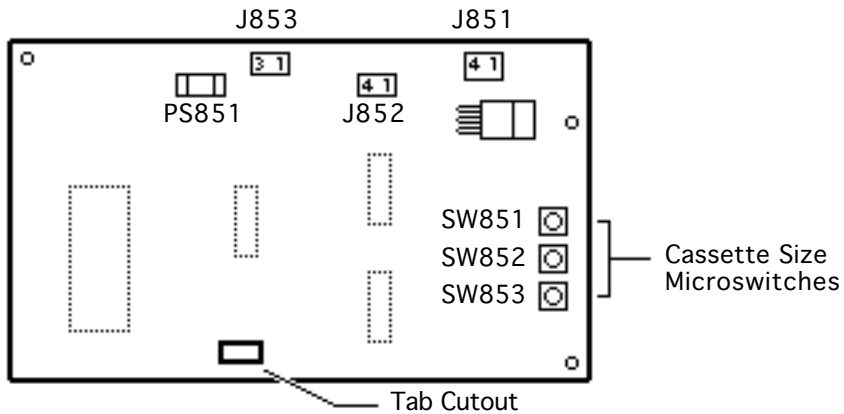





## Wiring Diagram

The LaserWriter 600/630 wiring diagram can be found on the next page. The detail in this document is too small to read easily at 100% view. You should either zoom into the diagram using the zoom tool above, or print the diagram on a laser printer with a resolution of 300 dpi (600 dpi preferred).



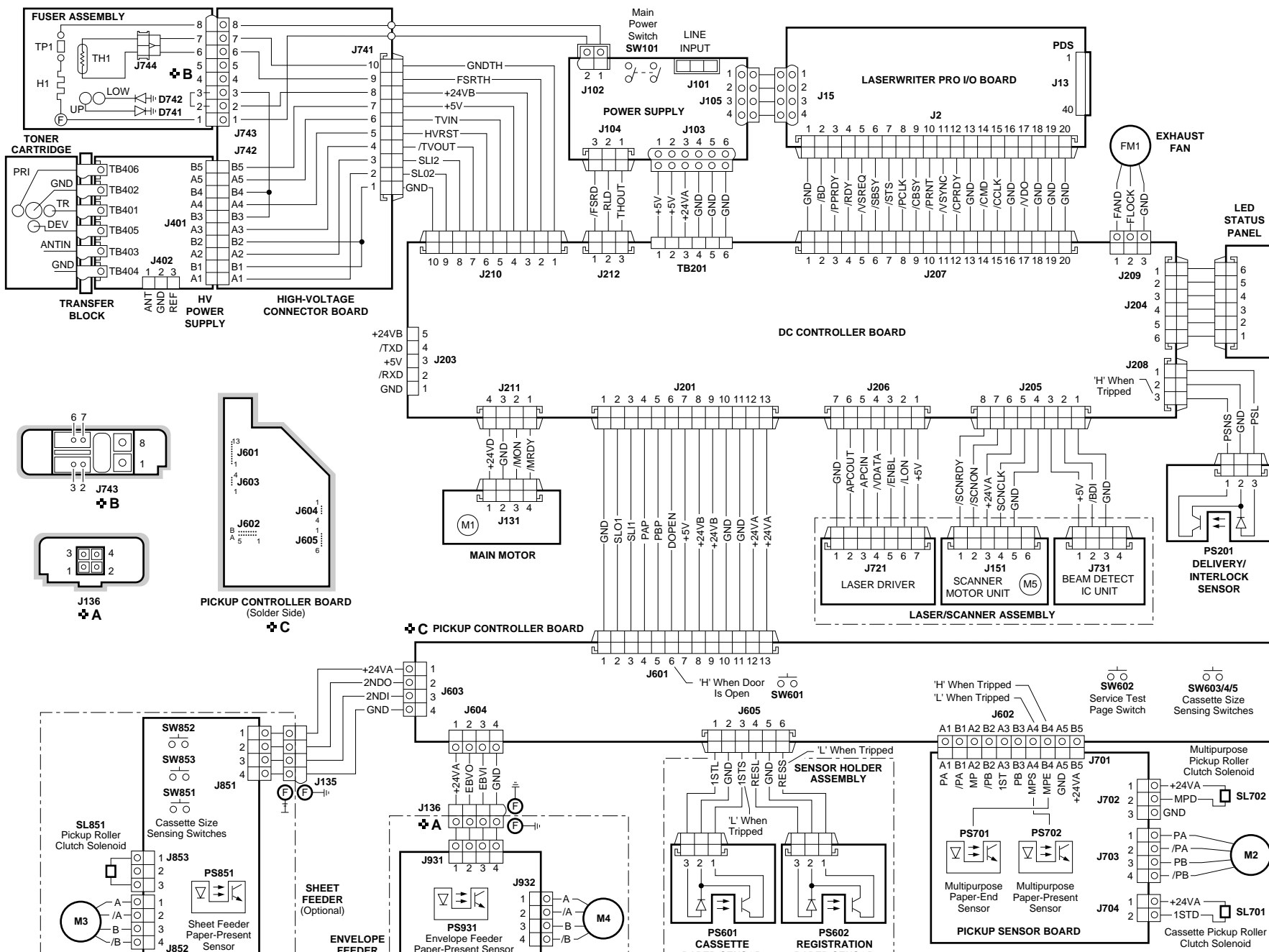

**LaserWriter Pro 600/630  
Wiring Diagram**



## Connector J136 Locator

J136 is the connector that the envelope feeder mates into. To see it, open the multipurpose tray and remove the closure panel. The illustration below shows the connector as it appears from the outside of the printer.

A voltage reading of 24V between pins 1 (+24VA) and 4 (GND) during printer startup indicates that motor power is reaching the envelope feeder.

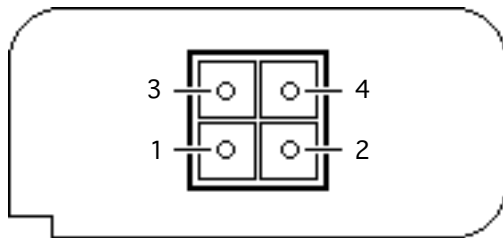



## Connector J743 Locator

J743 connects the fuser assembly to the high-voltage connecting block. A measurement of continuity between pins 1 and 8 indicates that the heater bulb and thermoprotector are intact. A measurement of continuity between pins 6 and 7 indicates that the thermistor is intact.

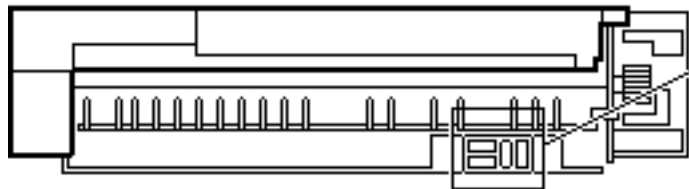

Fuser Assembly

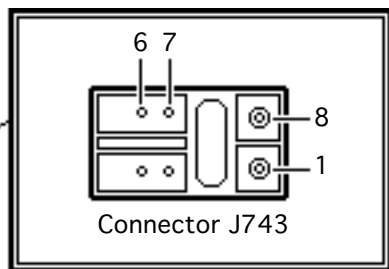



### LaserWriter Pro 600/630 Troubleshooting Flowchart

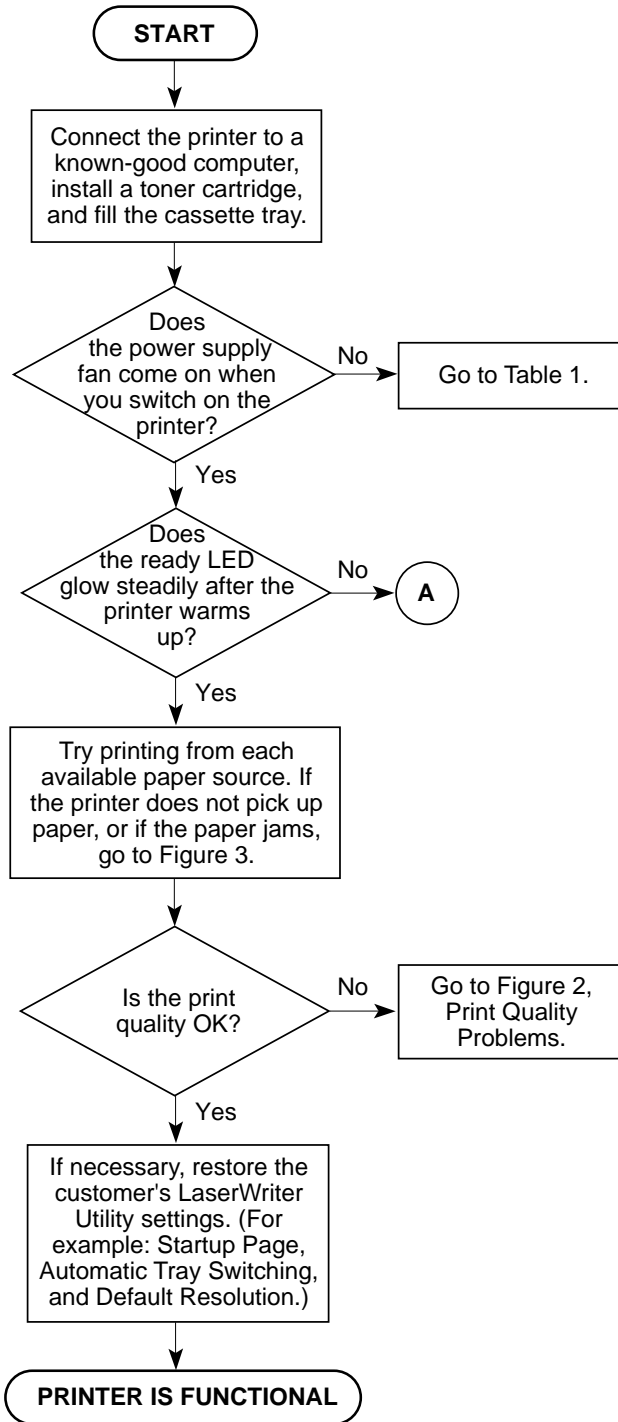

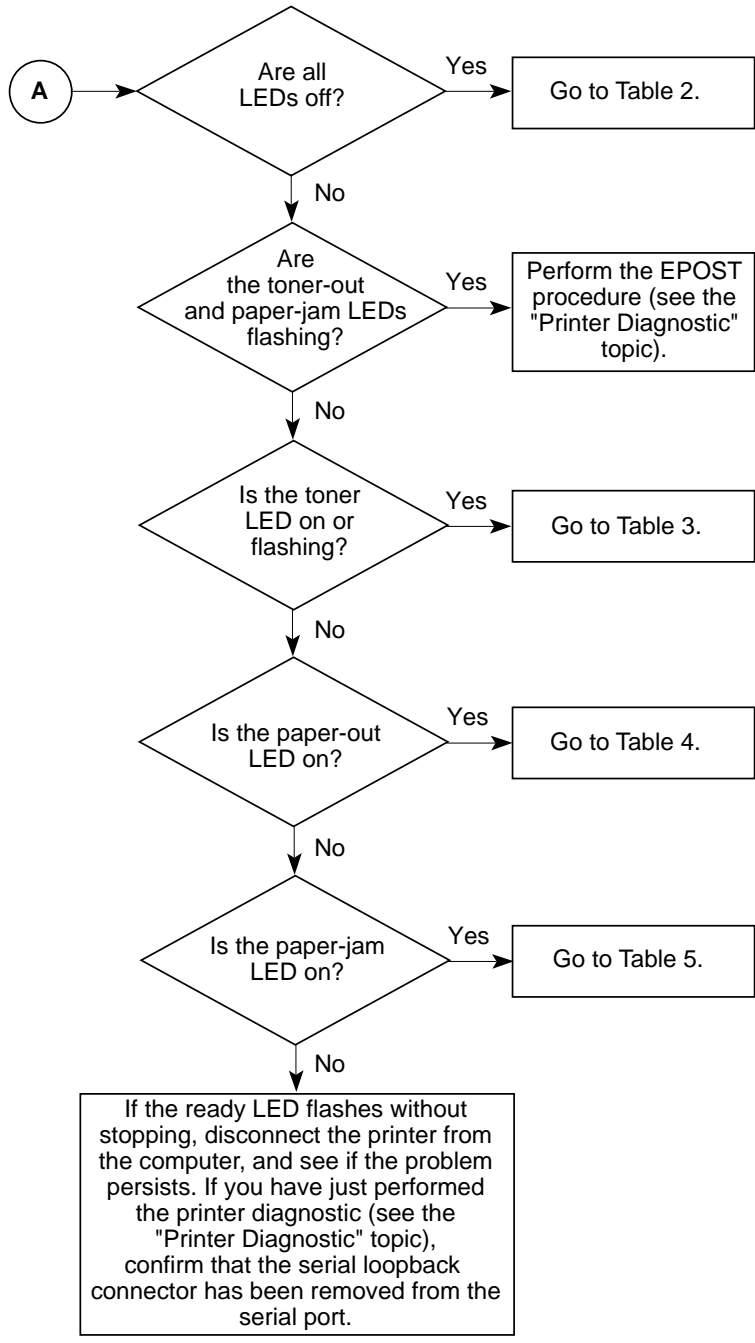



## Troubleshooting Tables

**Important** As you proceed through the steps in a table, remember to retry the printer each time you change its physical state—for example, when you replace a module. If the problem remains, reinstall the original module before proceeding to the next step in the table. Refer as necessary to the wiring diagram that follows the tables.

**Table 1. The Power Supply Fan Does Not Come On When You Switch On the Printer**

Step	Check	Result	Action
1	Does the power supply fan come on when you turn on the printer?	No	Remove the rear panel, I/O board, and I/O shield, and restart the printer.
		Yes	The problem is probably with the power supply fan or its connection to the DC controller board. Run the printer diagnostic. If the diagnostic suggests a fan problem, see Table 9.
2	Do any of the motors rotate after the printer starts up?	Yes	Check the connections at J213 and J214 on the DC controller board, and check that nothing physical is blocking the fan blades. If the problem persists, replace the DC controller board.
		No	Make sure J103 is connected at the power supply. If TB201 is detached from the DC controller, replace the DC controller board; otherwise, replace the power supply. If the problem persists, replace the DC controller board.



**Table 2. All LEDs Are Off After Printer Warmup**

Step	Check	Result	Action
1	Are the top cover and fuser door closed?	No	Close them completely, and confirm that the plastic tab actuators on the doors are intact. No LEDs illuminate if either door is open.
2	Remove the rear panel and I/O shield. Is the status panel cable securely connected to J204 on the DC controller board?	No	Secure the cable.
3	Can you print despite the fact no LEDs illuminate?	Yes	Check connection between the status panel and the DC controller board. If the connections are secure, replace the status panel.
4	Place probes between J208-2 (GND) and J208-3 (PSNS) on the DC controller board. Does the voltage rise to 5 V as you open the fuser door?	No	Replace the delivery/interlock assembly.
5	Place probes between J201-7 (+5 V) and J201-1 (GND) on the DC controller board. Switch on the printer. Does the voltage measure 5 V?	No	Replace the DC controller board.
6	Press the top cover interlock leaf spring. Do you hear the clicking sound of a microswitch when you press the spring?	No	Confirm that the black plastic actuator is in place behind the top of the pickup controller board.
7	Remove the paper pickup block and maintain pickup connectivity. Place probes between J601-11 (GND) and J601-7 (+5 V) on the solder side of the pickup controller board. Does the voltage measure 5 V?	Yes	Replace the pickup controller board.
		No	Replace the DC controller-board-to-pickup-controller-board cable.





**Table 3. Toner LED Is On or Flashes After Printer Warmup**

Step	Check	Result	Action
1	Try a known-good toner cartridge. Does the problem persist?	No	Problem solved.
2	Have you recently serviced the printer and has this symptom existed ever since?	Yes	You probably did not fully reseal the high-voltage power supply, connector block, or transfer block assembly; or connector J210 on the DC Controller board is not secure. Make sure these modules are securely installed.
3	Have you just performed the engine diagnostic?	Yes	Confirm there is not still a serial loop-back connector installed in the serial port.
4	Remove the toner cartridge and inspect all the toner contacts for damage or excess toner buildup. Are the contacts clean and in good condition?	No	Clean or repair the contacts if possible. Take special note of TB403, which is the pronged contact that the toner cartridge mates into. This contact ties into the toner sensor inside the cartridge.
5	Remove the rear panel and I/O shield. Place probes between J210-6 (HVRST) and J210-10 (GND) and switch on the printer. Does the voltage change from 0 to 5 V about one second after the printer starts up?	No  Yes	Replace the DC Controller board.  Perform the first module exchange below. If the problem persists, reinstall the original module and perform the next exchange: <ul style="list-style-type: none"> <li>• Replace the HV power supply</li> <li>• Replace the power supply-to-HVPS interface board.</li> <li>• Replace the transfer block assembly.</li> <li>• Replace the DC controller-board-to-HVPS cable.</li> </ul>



**Table 4. Paper-Out LED is On After Printer Warmup**

Step	Check	Result	Action
1	Is the cassette empty or not installed?	Yes	Make sure that the cassette is present and has paper.
2	Remove the cassette and inspect the paper-sensing lever. Is the lever broken?	Yes	Replace the sensor holder assembly.
3	Defeat the cassette paper sensing lever by pushing it and holding it in (as if a cassette were present). With your other hand, press the three microswitch leaf springs all at the same time. Does the ready LED illuminate after a couple of seconds?	Yes	Replace the pickup controller board.
4	Remove the rear panel and I/O shield. Place probes between J201-7 (+5 V) and J201-1 (GND) on the DC controller board. Switch on the printer. Does the voltage measure 5 V?	No	Replace the DC controller board.
5	Remove the paper pickup block and maintain pickup connectivity. Place probes between J601-11 (GND) and J601-7 (+5 V) on the solder side of the pickup controller board. Does voltage measure 5 V?	No	Replace the DC-controller-to-pickup-controller cable.
6	Measure the voltage between J605-5 (GND) and J605-3 (1STS). Does the voltage measure 5 V?	No	Replace the pickup controller board.
7	Keep the probes in the same position and manually trip the cassette sensor lever. Does the voltage drop to 0 V when you trip the lever?	No	Replace the sensor holder assembly.
		Yes	Replace the pickup controller board.

**Table 5. Paper-Jam LED is On After Printer Warmup**

<b>Step</b>	<b>Check</b>	<b>Result</b>	<b>Action</b>
1	Is the delivery/interlock sensor snagged?	Yes	Remove the top cover and delivery roller assembly, and un snag the sensor spring. The spring should be straight. If the actuator is snagged, it will not spring back and forth as you try to trip it.
2	Is the delivery-sensing lever snagged?	Yes	Remove the top cover and delivery roller assembly and see what is snagging the lever. If necessary, remove and dismantle the fuser assembly and replace the delivery-sensing lever.
3	Is the registration-sensing lever snagged?	Yes	If the lever is broken or snagged, remove the pickup block and troubleshoot further. If necessary, replace the sensor holder assembly.
4	Remove the rear panel, I/O shield, top cover, and delivery roller assembly. Is the purple cable between the delivery/interlock sensor and the DC controller board securely connected?	No	Secure the cable.
5	Place probes between J208-2 (GND) and J208-3 (PSNS). Does the voltage rise to 5 V as you open the fuser door?	No	Replace the delivery/interlock assembly.
6	Place probes between J201-7 (+5 V) and J201-1 (GRD) on the DC controller board. Does the voltage measure 5 V?	No	Replace the DC controller board.



**Table 5. Paper-Jam LED is On After Printer Warmup (Continued)**

Step	Check	Result	Action
7	Remove the paper pickup block and maintain pickup connectivity. Place probes between J601-7 (+5 V) and J601-11 (GND) on the solder-side of the pickup controller board. Does the voltage measure 5 V?	No	Replace the DC-controller board-to-pickup-controller-board cable.
8	Place probes between J605-6 (RESS) and J605-5 (GND). Does the voltage measure 5 V?	No	Replace the pickup controller board.
9	Keep the probes in the same position and manually trip the registration sensor lever. Does the voltage drop to 0 V when you trip the lever?	No	Replace the sensor holder assembly.
		Yes	Replace the DC controller board.

**Important**

When there is a failure of the fusing system, the DC controller board shuts off current to the fuser roller heater and charges capacitor C202 on the DC controller board to prevent overheating. If there is a failure of the fusing system, you must turn off the power and leave it off for about 10 minutes, or manually discharge the capacitor before switching power back on.

**Table 6. Fuser Assembly Error**

Step	Check	Result	Action
1	Remove the rear panel, I/O board, and I/O shield. Is connector J210 on the DC controller board secure?	No	Secure the connector.
2	Is the power supply firmly seated?	No	Seat the power supply.

**Table 6. Fuser Assembly Error (Continued)**

Step	Check	Result	Action
3	Remove the fuser assembly and let it cool. Measure the resistance between J743-6 and J743-7 on the fuser. (Refer to the wiring diagram for illustration and pin layout of connector J743.) Does the resistance measure between 180 and 280 k $\Omega$ ?	No	Disconnect J744 and check for same resistance. Replace the thermistor or the connector cable, as needed.
4	Measure the resistance between J743-1 and J743-8 on the fuser. Does the resistance measure approximately 3 $\Omega$ or less?	No	If there is continuity through the heater bulb, replace the heater bulb. If there is continuity across the thermoprotector, replace the fuser connector cable. If there is not continuity across the thermoprotector replace the thermoprotector, and proceed to the next step.
5	Reinstall the fuser. Place probes between J212-1 (/FSRD) and TB201-6 (GND) on the DC controller board. Does the voltage change from approximately 5.1 V to 1.5 V a few seconds after the printer starts up?	No	Replace the DC controller board.
6	Place probes between J212-2 (RLD) and TB201-6 (GND). Does the voltage measure approximately 2.1 V?	No Yes	Replace the DC controller board. Replace the power supply.



**Table 7. Laser/Scanner Error**

Step	Check	Result	Action
1	Remove the rear panel and I/O shield. Are the DC controller board connectors J205 and J206 secure?	No	Secure the cables.
2	Remove the top cover and delivery roller assembly. Are all three laser/scanner assembly connectors secure?	No	Secure the cables.
3	Remove the two cables that run from the DC controller board to the laser/scanner assembly and check the resistance of each. Is the resistance approximately 1 ohm or less for each wire?	No  Yes	Replace the defective cable.  Replace the laser/scanner assembly. If the problem persists, reinstall the original module and replace the DC controller board.

**Table 8. Main Motor Error**

Step	Check	Result	Action
1	Remove the rear panel and I/O shield. Is the main motor cable secure at J211 on the DC controller board?	No  Yes	Secure the cable.  Perform the first module exchange listed below. If the problem persists, reinstall the original module and perform the next exchange: <ul style="list-style-type: none"> <li>• Replace the main motor.</li> <li>• Replace the DC controller board.</li> <li>• Replace the main motor cable.</li> </ul>

**Table 9. Fan Error**

<b>Step</b>	<b>Check</b>	<b>Result</b>	<b>Action</b>
1	Remove the rear panel and I/O shield. Is the fan cable secure at J209 on the DC controller board?	No	Secure the cable.
2	Place probes at J209-1 (FAND) and J209-3 (GND). Does the voltage change from approximately 24.5 to 16 V a few seconds after the printer starts up?	No	Replace the DC controller board.
3	Place the probes at J209-2 (FLOCK) and J209-3 (GND) on the DC controller board, and switch on the power. Does the voltage measure 2.2 V or more?	Yes  No	Replace the fan.  Replace the DC controller board.

**Table 10. I/O Board Error**

<b>Step</b>	<b>Check</b>	<b>Result</b>	<b>Action</b>
1	Do the diagnostic LEDs indicate an I/O board error?	Yes	Replace the I/O board.
2	Did you receive a SIMM error?	Yes	Replace the faulty SIMM.
3	Did you receive a ROM error?	Yes	Replace the I/O board.





The following graphic shows examples of image quality defects. Refer to the appropriate troubleshooting table to correct the quality of the image.

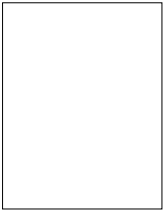

**All-Blank Page**

See Table 11

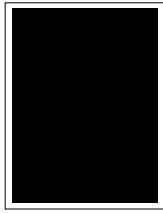

**All-Black Page**

See Table 12



**Light/Faded Image**

See Table 13

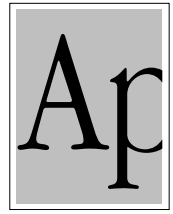

**Dark Image**

See Table 14

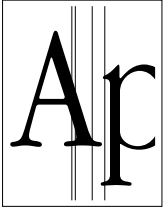

**Black Vertical Line(s)**

See Table 15

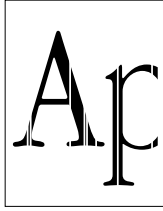

**White Vertical Line(s)**

See Table 16

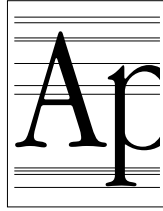

**Black Horizontal Lines**

See Table 17

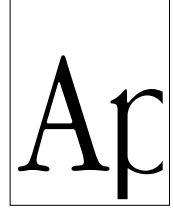

**Bad Registration**

See Table 18

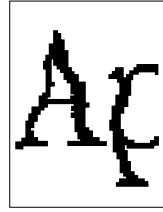

**Stair-stepping**

See Table 19

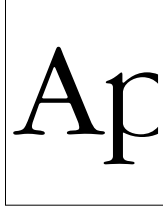

**Vertical Distortion**

See Table 20

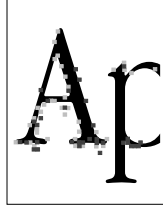

**Bad Fusing**

See Table 21

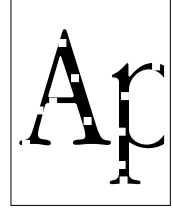

**Blank Spots**

See Table 22

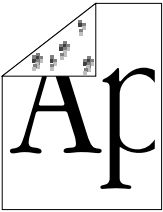

**Toner on Back**

See Table 23

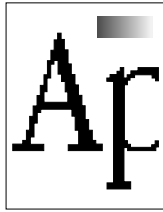

**Cannot Print in PhotoGrade**

See Table 24

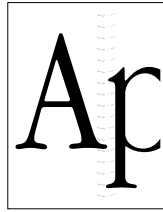

**Repetitive Defects**

See Table 25

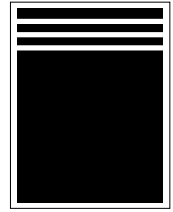

**White Horizontal Stripes**

See Table 7

**Figure 2. Print Quality Problems**



**Table 11. All-Blank Page**

Step	Check	Result	Action
1	Is the sealing tape removed from the toner cartridge?	No	Remove the sealing tape.
2	Have you recently installed a laser/scanner unit and has this symptom existed since?	Yes	The laser shutter may have been installed incorrectly. The shutter should spring back and forth as you insert the toner cartridge.
3	Does this symptom occur only with envelopes?	Yes	Instruct the customer to adjust margins in the software application.
4	Run the Extended Power-On Self Test. Does the test indicate a specific error?	Yes	Go to the appropriate troubleshooting table that describes the error indicated.
5	Remove the rear panel and I/O shield. Place probes between J210-6 (HVRST) and J210-10 (GND). Does the voltage change from 0 to 5 V about one second after the printer starts up?	No	Replace the DC controller board.
6	Place probes between J210-9 (SLO2) and J210-10 (GND). Does the voltage measure approximately 0.7 V about one second after the main motor starts?	No  Yes	Replace the DC controller board.  Perform the first module exchange listed below. If the problem persists, reinstall the original module and perform the next exchange: <ul style="list-style-type: none"> <li>• Replace the high-voltage power supply.</li> <li>• Replace the power-supply-to-HVPS interface board.</li> <li>• Replace the transfer block assembly.</li> </ul>

**Table 12. All-Black page**

<b>Step</b>	<b>Check</b>	<b>Result</b>	<b>Action</b>
1	Run the Extended Power-On Self Test (see “Printer Diagnostics”). Does the test indicate a specific error?	Yes	Go to the appropriate troubleshooting table that describes the error indicated.
2	Place probes between J210-9 (SLO2) and J210-10 (GND). Does the voltage measure approximately 0.7 V about one second after the main motor starts?	No  Yes	Replace the DC controller board.  Perform the first module exchange listed below. If the problem persists, reinstall the original module and perform the next exchange: <ul style="list-style-type: none"><li>• Replace the high-voltage power supply.</li><li>• Replace the power-supply-to-HVPS interface board.</li></ul>

**Table 13. Uniformly Light/Faded Image Over Entire Page**

<b>Step</b>	<b>Check</b>	<b>Result</b>	<b>Action</b>
1	Adjust the density using the Printer Utility. Does the problem persist?	No	Problem solved.
2	Try printing with known-good paper. Does the problem persist?	No	Problem solved.
3	Replace the transfer roller with a known-good transfer roller. Does the problem persist?	No	Problem solved.
4	Have you recently serviced the printer and has this symptom existed ever since?	Yes	Confirm that the high-voltage power supply is installed correctly and that good contact is being made with the transfer block assembly.
5	Remove the rear panel and I/O shield. Place probes between J210-9 (SLO2) and J210-10 (GND) and switch on the printer. Does the voltage read about 0.7 V about one second after the main motor starts?	No  Yes	Replace the DC controller.  Replace the high-voltage power supply. If the problem persists, replace the high-voltage connector board.



**Table 14. Uniformly Dark Image Over Entire Page**

Step	Check	Result	Action
1	Adjust the density using the Printer Utility. Does the problem persist?	No	Problem solved.
2	Try printing with known-good paper. Does the problem persist?	No	Problem solved.
3	Clean the printer drum grounding contact and cartridge contact and print a test page. Does the problem persist?	No	Problem solved.
4	Remove the rear panel and I/O shield. Place probes between J210-6 (HVRST) and J210-10 (GND). Does the voltage change from 0 to 5 V about one second after the printer starts up?	No  Yes	Replace the DC controller board.  Replace the high-voltage power supply. If the problem persists, replace the high-voltage connector board.

**Table 15. Black Vertical Lines, Sharp and Well-Defined**

Step	Check	Result	Action
1	Try a known-good toner cartridge. Does the problem persist?	No	Problem solved.
2	Does the symptom occur on a service test page?	No  Yes	Replace the I/O board.  Replace the fuser assembly. If the problem persists, replace the laser/scanner assembly.

**Table 16. White Vertical Lines, Sharp and Well-Defined**

<b>Step</b>	<b>Check</b>	<b>Result</b>	<b>Action</b>
1	Try a known-good toner cartridge. Does the problem persist?	No	Problem solved.
2	Is there a hair or other obstruction that can be blocking the laser beam?	Yes	Remove the obstruction.
3	Does the symptom appear on the service test page?	No	Replace the I/O board.
		Yes	Replace the laser/scanner assembly.

**Table 17. Black Horizontal Lines, Sharp and Well-Defined**

<b>Step</b>	<b>Check</b>	<b>Result</b>	<b>Action</b>
1	Try a known-good toner cartridge. Does the problem persist?	No	Problem solved.
2	Does the symptom appear on the service test page?	No	Replace the I/O board.
		Yes	Replace the laser/scanner assembly.



**Table 18. Bad Registration/Image Cut Off**

Step	Check	Result	Action
1	Try printing with less paper at the source. Does the problem persist?	No	Problem solved.
2	Run a print from a different paper source. Does the problem persist?	No	Replace or reinstall the faulty pickup roller.
3	Perform the registration adjustment (see "Registration Adjustment" in this chapter). Does the problem persist?	No Yes	Problem solved. Replace the sensor holder assembly.

**Table 19. Stairstepping/Vertical Lines Jagged or Shaky**

Step	Check	Result	Action
1	Run a service test page. Does the problem persist?	No	Replace the I/O board.
2	Run the Extended Power-On Self Test (see "Printer Diagnostics"). Does the test indicate a specific error?	Yes No	Go to the appropriate troubleshooting table that describes the error indicated. Replace the laser/scanner assembly. If the problem persists, replace the DC controller board.



**Table 20. Vertical Elongation or Foreshortening**

Step	Check	Result	Action
1	Run the Extended Power-On Self Test (see “Printer Diagnostics”). Does the test indicate a specific error?	Yes	Go to the appropriate troubleshooting table that describes the error indicated.
		No	Perform the first module exchange listed below. If the problem persists, reinstall the original module and perform the next exchange: <ul style="list-style-type: none"> <li>• Replace the laser/scanner assembly.</li> <li>• Replace the DC controller board.</li> <li>• Replace the main motor.</li> </ul>

**Table 21. Bad Fusing**

Step	Check	Result	Action
1	Are the fuser roller levers in a down (print-mode) position?	No	Set the envelope levers to a down (print-mode) position.
		Yes	Go to Table 6, Fuser Assembly Error.

**Table 22. Blank Spots/Random Pattern or Location**

Step	Check	Result	Action
1	Try printing with known-good paper. Does the problem persist?	No	Problem solved.
2	Are humidity conditions according to specifications?	No	Inform the customer of the changes that are necessary.
3	Are you printing on the correct side of the paper?	No	Turn over the paper.
		Yes	Go to Table 21, Bad Fusing.





**Table 23. Toner on Back of Page**

Step	Check	Result	Action
1	Is the toner smudge in a small area behind the upper-left corner of the page?	Yes	Clean or replace the pickup roller.
		No	Clean with a dry, lint-free cloth or replace the transfer roller, transfer guide assembly, or lower fuser roller.

**Table 24. Cannot Print in PhotoGrade**

Step	Check	Result	Action
1	Have you upgraded printer memory to 12 MB of RAM?	No	You must have a minimum of 12 MB of RAM to run PhotoGrade at 600 dpi.

**Table 25. Repetitive Defects**

Step	Check	Result	Action
1	Try a known-good toner cartridge. Does the problem persist?	No	Problem solved.
2	Does the symptom occur on a service test page?	No	Replace the I/O board.
3	Is the repetitive staining along the left edge of the paper?	Yes	Clean the feeder rollers with a dry, lint-free cloth.
4	Interrupt a print cycle (see "Interrupting a Print Cycle" under "Troubleshooting Tips"). Is the symptom present on the drum?	Yes	Clean or replace the pickup/transfer rollers and guides as required.
		No	Clean or replace the fuser or delivery rollers.



**Table 26. Picking Up From Wrong Source**

Step	Check	Result	Action
1	Is the selected paper source empty?	Yes	Select Paper Handling in the Apple Printer Utility and disable the Tray Switching option if you do not want paper to feed from a secondary source when the selected source is empty.
		No	There is a problem in the sensing system. Make sure that automatic tray switching is off and try printing again. If there are jam or pickup problems at that point, refer to Figure 3.

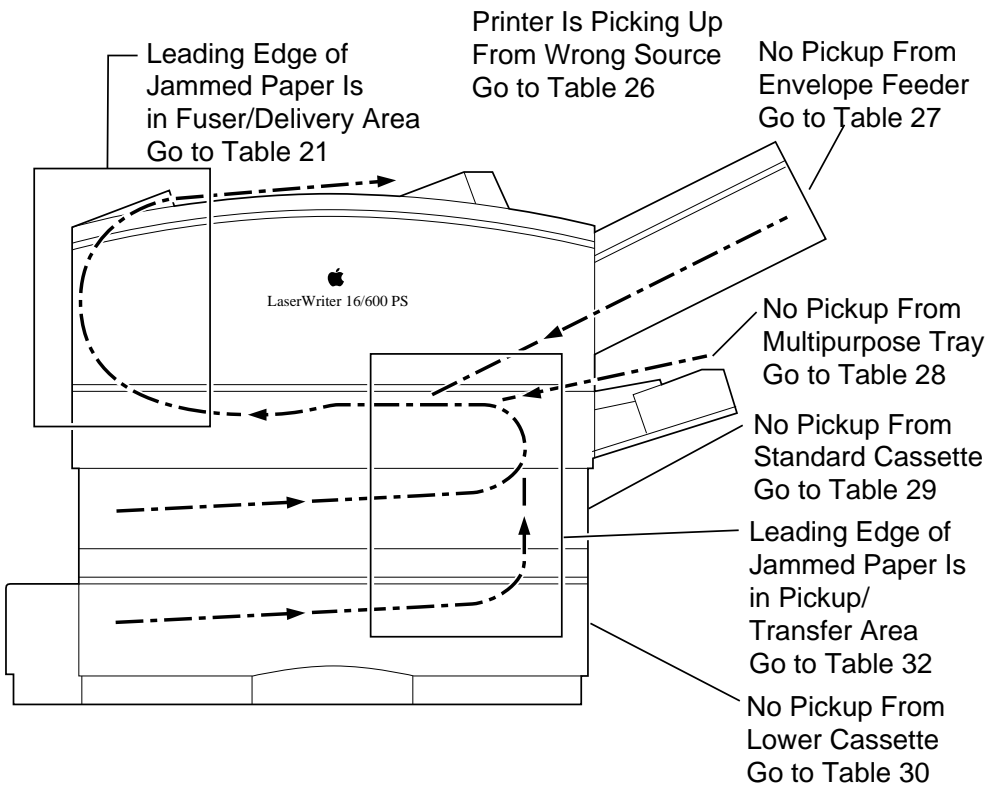

**Figure 3. Paper Transport Problems**



**Table 27. No Pickup From Envelope Feeder**

Step	Check	Result	Action
1	Is paper picking up correctly from the standard cassette?	No	Go to Table 29.
2	Remove the left, right, and bottom covers of the envelope feeder and install the feeder into the pickup block. Do the envelope feeder motor and gearing engage after you restart?	Yes	Remove the paper pickup block from the printer and maintain pickup connectivity (see “Troubleshooting Tips” in this chapter).
3	Place probes on the solder side of the pickup controller board between J603-4 (GND) and the power supply side of diode D606. Does the voltage measure 5 V?	No Yes	Replace the pickup controller board.  Perform the first module exchange below. If the problem persists, reinstall the original module and perform the next exchange: <ul style="list-style-type: none"> <li>• Replace the envelope feeder controller board.</li> <li>• Replace the printer interface cable in the envelope feeder.</li> <li>• Replace the feeder interface cable in the pickup block.</li> </ul>
4	Measure the voltage between J604-4 (GND) and J604-1 (+24 V). Does the voltage measure 24 V?	No	Replace the pickup controller board.
5	Place probes between J136-1 (+24 V) and J136-4 (GND) on the receptacle that the envelope feeder plugs into. Does the voltage measure 24 V?	No Yes	Replace the feeder interface cable.  Perform the first module exchange below. If the problem persists, reinstall the original module and perform the next exchange: <ul style="list-style-type: none"> <li>• Replace the envelope feeder controller board.</li> <li>• Replace the envelope feeder motor.</li> <li>• Replace the printer interface cable inside the envelope feeder.</li> </ul>

**Table 28. No Pickup From Multipurpose Tray**

<b>Step</b>	<b>Check</b>	<b>Result</b>	<b>Action</b>
1	Is paper picking up correctly from the standard cassette?	No	Go to Table 29
2	Maintain I/O connectivity (see “Troubleshooting Tips” in this chapter). Do the pickup motor and gearing engage after you try printing to the multipurpose tray?	No	Remove the rear panel and the right corner panel and check that all the following connectors are secure: <ul style="list-style-type: none"><li>• DC controller board connector J201</li><li>• Pickup controller board connector J601</li><li>• Pickup block motor cable J703</li></ul>
3	Remove the paper pickup block and maintain pickup connectivity (see “Troubleshooting Tips” in this chapter). Closely observe the gear at the end of the pickup block and restart the printer. Do all gears rotate correctly after you restart?	No	Remount or replace the problem gear(s).
4	Select the multipurpose tray as paper source, and print something. Does the multipurpose pickup gear rotate?	No	Make sure that the pickup gear and its spring and hook are installed correctly. If the problem persists, replace the multipurpose pickup solenoid.
5	The problem is mechanical and is caused by failure of one of these components. Restart the printer and attempt another print job. Observe the components closely. Does the symptom persist?	Yes	Remount, clear, or replace the defective component.

**Table 29. No Pickup From Standard Cassette**

Step	Check	Result	Action
1	Initiate a service test page. Does the printer pickup from the standard cassette?	Yes	Confirm that I/O cable connections are secure and that configuration settings are correct. To make certain that networking or CPU software is not the root problem, confirm through the printer utility that the startup page is enabled, and restart the printer. If the startup page prints, there is a software or networking problem away from the printer. If the startup page does not print, replace the I/O board.
2	Do the pickup motor and gearing engage after you restart the printer?	Yes	Remove the paper pickup block and maintain pickup connectivity. Closely observe the gear end of the pickup block and restart the printer. All but three ratchet gears should spin freely during the startup sequence. If the problem persists, remount or replace the problem gear(s).
3	Remove the rear panel and the right corner panel. Is the pickup controller board cable securely connected to J201 on the DC controller board?	No	Secure the cable.
4	Is the DC controller board cable securely connected to J601 on the pickup controller board?	No	Secure the cable.
5	Is the pickup block motor cable securely connected at J703 on the pickup sensor board?	No	Secure the cable.



**Table 29. No Pickup From Standard Cassette (Continued)**

Step	Check	Result	Action
6	Disconnect J201 on the DC controller board. Place probes between pins J201-1 (GND) and J201-13 (+24 V) on the male connector on the board. Does the voltage measure 24 V?	No  Yes	Replace the DC controller board.  Replace the pickup-to-DC controller board cable.
7	Place probes between pins J201-1 (GND) and J201-7 (+5 V) on the male connector on the board. Does the voltage measure 5 V?	No	Replace the DC controller board.
8	Reconnect J201. Remove the paper pickup block and maintain pickup connectivity. Measure the voltage between J601-11 (GND) and J601-13 (+24 V) on the pickup controller board. Does the voltage measure 24 V?	No	Replace the pickup-controller-to-DC-controller-board cable.
9	Place probes between pins J601-1 (GND) and J601-7 (+5 V). Does the voltage measure 5 V?	No	Replace the pickup-controller-to-DC-controller-board cable.
10	Place probes between pins J601-1 (GND) and J601-9 (+24 V). Does the voltage measure 24 V?	No  Yes	Replace the pickup controller board.  Perform the first module exchange below. If the problem persists, reinstall the original module and perform the next exchange: <ul style="list-style-type: none"> <li>• Replace the pickup motor.</li> <li>• Replace the pickup sensor board.</li> </ul>



**Table 30. No Pickup From Lower Cassette**

Step	Check	Result	Action
1	Is paper picking up correctly from the standard cassette?	No	Go to Table 29.
2	Disable the startup test page, and remove the top cover, rear panel, and right corner panel from the printer. Disconnect J603 from the exposed edge of the controller board and connect a spare sheet feeder interface cable. Plug the opposite end of the interface cable into the sheet feeder receptacle. Is paper now picked up from the lower cassette?	Yes	Replace the sheet feeder interface cable.
3	Reinstall the sheet feeder and restart the printer. Do the sheet feeder gearing and motor rotate?	No	<p>Confirm that the sensing arm is intact and that the lower cassette is installed. Check that the following connectors are secure:</p> <ul style="list-style-type: none"> <li>• Connector J201 on the DC controller board.</li> <li>• The two connectors at the edge of the pickup controller board.</li> <li>• The three connectors at the edge of the sheet feeder controller board.</li> </ul>
4	Switch off the printer and remove the 4-pin cable from connector J603 along the front edge of the pickup controller board. Place probes between J603-1 (+24 V) and J603-4 (GND) on the pickup controller board. Does the voltage measure 24 V when you switch on the printer?	<p>No</p> <p>Yes</p>	<p>Replace the pickup controller board.</p> <p>Perform the first module exchange listed below. If the problem still persists, reinstall the original module and perform the next exchange.</p> <ul style="list-style-type: none"> <li>• Replace the sheet feeder controller board.</li> <li>• Replace the sheet feeder controller block.</li> <li>• Replace the sheet feeder motor.</li> </ul>

**Table 30. No Pickup From Lower Cassette (Continued)**

<b>Step</b>	<b>Check</b>	<b>Result</b>	<b>Action</b>
5	Remove the paper pickup block and maintain pickup connectivity (see “Troubleshooting Tips” in this chapter). Place probes on the solder side of the pickup controller board on J603-4 (GND) and the power supply side of diode D606. Does the voltage measure 5 V when you switch on the printer?	Yes	Perform the first module exchange listed below. If the problem still persists, reinstall the original module and perform the next exchange. <ul style="list-style-type: none"><li>• Replace the sheet feeder controller board.</li><li>• Replace the sheet feeder pickup solenoid.</li><li>• Replace the sheet feeder controller block.</li><li>• Remount and/or replace the pickup shaft gear and roller.</li></ul>
6	Place probes between pins J201-1 (GND) and J201-7 (+5 V) on the DC controller board. Does the voltage measure 5 V?	No	Perform the first module exchange listed below. If the problem still persists, reinstall the original module and perform the next exchange. <ul style="list-style-type: none"><li>• Replace the I/O board</li><li>• Replace the DC controller board.</li></ul>
		Yes	Replace the pickup controller board.





**Table 31. Leading Edge of Jammed Paper Is in Fuser/Delivery Area**

Step	Check	Result	Action
1	Do the delivery rollers turn when you start up the printer?	No	Go to Step 6.
2	Is there crumpled paper just outside the exit point of the fuser assembly?	Yes	A snagged sensing lever is probably the cause of the problem. Remove the top cover and delivery roller assembly, and inspect the delivery/interlock sensor. If the delivery-sensing lever is broken, replace it.
3	Is there an accordian-style jamming just short of the paper delivery tray?	Yes	The delivery guide pins might have been installed incorrectly. These are the four small pins on the delivery roller assembly. They should point outward, with the flow of paper.
4	Does jamming occur only when paper feeds from the multipurpose tray?	Yes	Inspect the sensing lever for multipurpose paper-end sensor PS701. Unsnag or replace it if it is damaged.
5	Remove the rear panel and I/O shield. Place probes between J208-2 (GND) and J208-3 (PSNS) on the DC controller board. Does the voltage rise from 0 to 5 V as you open the fuser access door?	Yes	Replace the DC controller board.
		No	Replace the delivery/interlock sensor.
6	Remove the rear panel and I/O shield. Restart the printer and observe the main motor. Does the main motor spin when the printer starts up?	Yes	Trace mechanical drive components from the delivery rollers back to the main motor, taking special note of the delivery drive belt. Clean or replace parts as necessary.
7	Make sure that the main motor is secure at J211 on the DC controller board, then run the Extended Power-On Self Test. Does the diagnostic indicate a main motor error?	Yes	Go to Table 8.
		No	Check main motor drive components for binding or improper installation. Clean or replace parts as required.



**Table 32. Leading Edge of Jammed Paper Is in Pickup/Transfer Area**

Step	Check	Result	Action
1	Try printing with known-good paper. Does the problem persist?	No	Problem solved.
2	Try feeding the paper from one of the other paper sources. Does jamming still occur?	No	Go to Table 33, 34, 35, or 36, as applicable.
3	Remove the toner cartridge, hold the green knob, and lift the delivery guide. Does the registration sensor arm move back and forth freely when you flick it with your finger?	No	Clear it if possible. If the arm is snagged beyond repair, replace the sensor holder assembly.
4	Check for obstructions, especially beneath the upper guide plate situated between the pickup block and the transfer roller. Are there obstructions?	Yes	Clear the obstructions.
5	Is the trailing edge of the jammed paper about an inch short of the registration sensor arm?	Yes	If paper has jammed there, especially if there is no sign of crumpling, there is almost certainly a failure in the delivery sensing system. Go to Table 31.
6	Remove the paper pickup block from the printer and maintain pickup connectivity. You will be taking measurements from the solder side of the pickup controller board. Place probes between J605-5 (GND) and J605-6 (RESS) and manually trip the registration sensor arm. Does the voltage measure about 5 V (normal) and 0 V (tripped)?	Yes  No	Replace the pickup controller board.  Replace the sensor holder assembly.



**Table 33. Paper Jams in Pickup/Transfer Area When Feeding From the Standard Cassette**

Step	Check	Result	Action
1	Is the black ribbed paper guide firmly seated?	No	Reseat the black ribbed paper guide. If this guide is damaged or unseated, paper may jam at the entrance to the paper pickup block.
2	Is the white passive roller on the cassette OK?	No	Clean the roller so that it forms a smooth gripping surface against the lower feed roller.
3	Is the lower feed roller OK?	No	Replace or reinstall the lower feed roller and/or its gearing. Note that the upper feed rollers serve other paper sources, so they are not likely to be the cause of the problem.

**Table 34. Paper Jams in Pickup/Transfer Area When Feeding From the Multipurpose Tray**

Step	Check	Result	Action
1	Try printing with known-good paper. Does the problem persist?	No	Problem solved.
2	Is the multipurpose tray width guide set correctly?	No	Set the guide so that it is snug against the edge of the paper.
3	Is the multipurpose pickup roller slipping when it tries to pull in the paper?	Yes	Reinstall or replace the multipurpose pickup roller. If you have recently taken apart the pickup block gearing and paper has not fed successfully since then, the problem could be incorrect installation of the gears.
4	Are there two sheets at the jam location?	Yes	Replace the multipurpose tray guide assembly.

**Table 35. Paper Jams in Pickup/Transfer Area When Feeding From the Optional Sheet Feeder**

<b>Step</b>	<b>Check</b>	<b>Result</b>	<b>Action</b>
1	Is the black ribbed paper guide firmly seated?	No	Reseat the black ribbed paper guide. If this guide is damaged or unseated, paper may jam at the entrance to the paper pickup block.
2	Is the standard 250-sheet cassette installed and in good condition?	No	Paper fed from the sheet feeder passes through the slit in the standard cassette located 2 inches back from the face plate. Make sure the standard cassette is fully inserted and that no blockage exists in this opening.
3	Are the feeder rollers in the sheet feeder OK?	No	The sheet feeder has one primary and two passive feeder rollers. Because power is reaching the pickup roller, any problem would probably be with binding or obstruction in the roller/gear system. Perform the sheet feeder bypass procedure and observe the functioning of the feeder components.

**Table 36. Paper Jams in Pickup/Transfer Area When Feeding From the Envelope Feeder**

Step	Check	Result	Action
1	Is the envelope feeder width guide set correctly?	No	Set the guide so that it is snug against the edge of the envelopes.
2	Is the envelope feeder correctly installed into the printer?	No	Reinstall the feeder so that it is mounted solidly onto the black positioning pin in the upper-left corner of the pickup block opening. If the feeder isn't mounted correctly, or if the pin is damaged, the pickup block entrance may not align properly.
3	Have you recently taken the feeder apart and has it exhibited this problem since then?	Yes	You may not have reinstalled the gear/roller system correctly. Refer to <i>Service Source CD</i> for more information.
4	Is the fork-shaped separation guide installed correctly?	No	There should be a 1.5 mm opening between the separation guide and the primary feed roller. Refer to the Adjustments chapter in the LW Envelope Feeder manual for more information.



Take Apart

---

LaserWriter Pro 600/630





## Rear Panel

No preliminary steps are required before you begin this procedure.

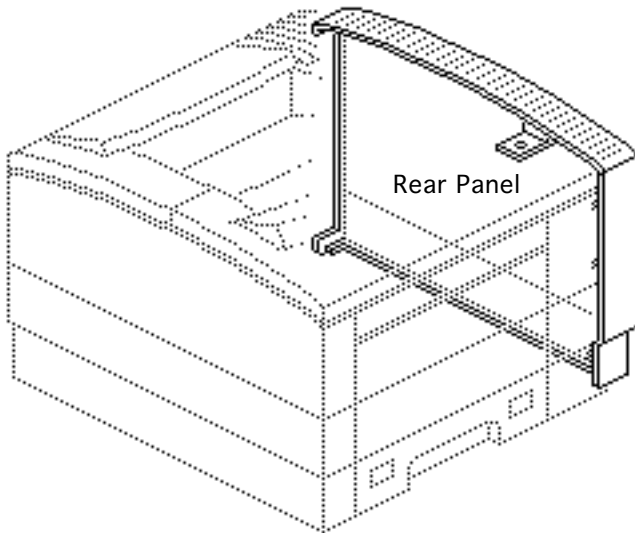



Cover Liner Screw



- 1 Open the toner access cover and remove the cover liner screw.
- 2 Grip the upper corner of the rear panel with your left hand as shown.

Rear Panel







- 3 Place your right fingertips on the I/O-label end of the rear panel, swing the panel outwards, and remove the panel from the printer.

**Replacement Note:**

Angle the three hooks in the rear panel into the openings in the right rear panel. Then swing the rear panel closed, being sure to slide the tab beneath the cover liner. If the cover liner screw hole does not line

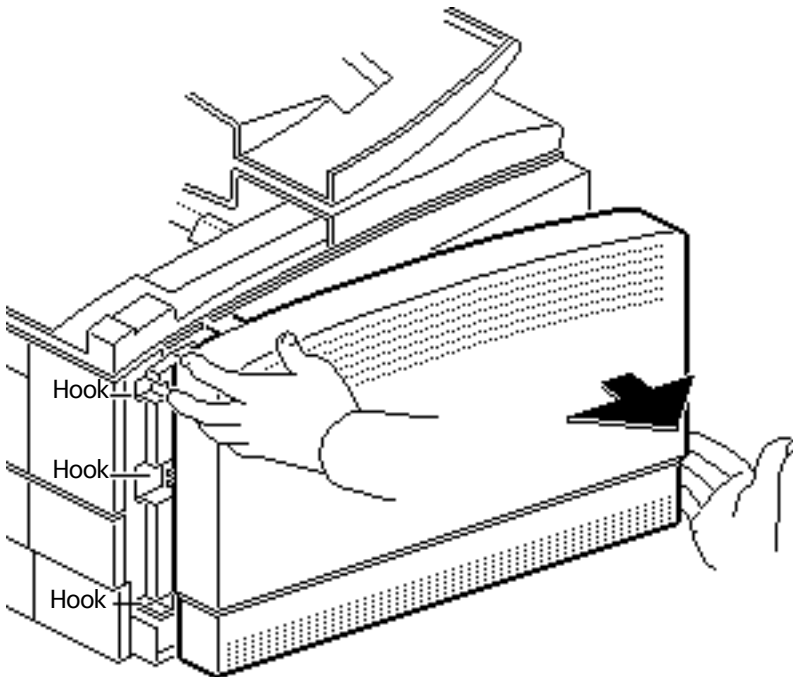



up, gently strike the I/O-label end of the panel with the base of your palm to position the panel properly.



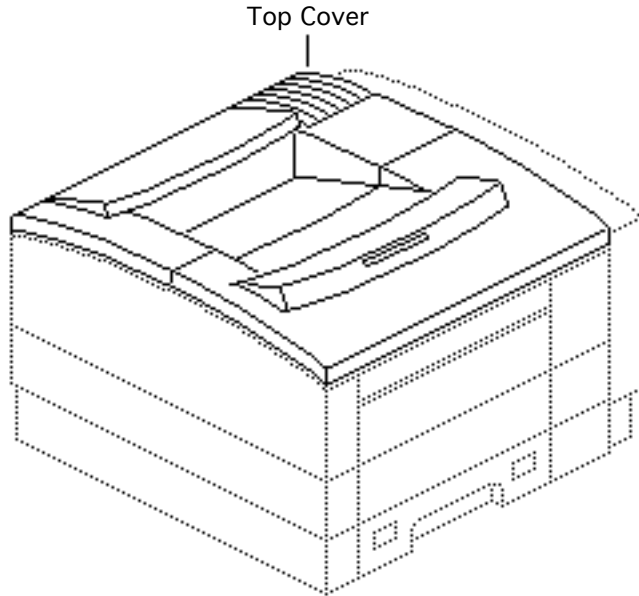

## Top Cover

Before you begin, open the multipurpose tray and remove the rear panel

**Note:** The cover liner comes off with the removal of the top cover.





Screw

Screw

- 1 Remove the two screws inside the fuser access door.

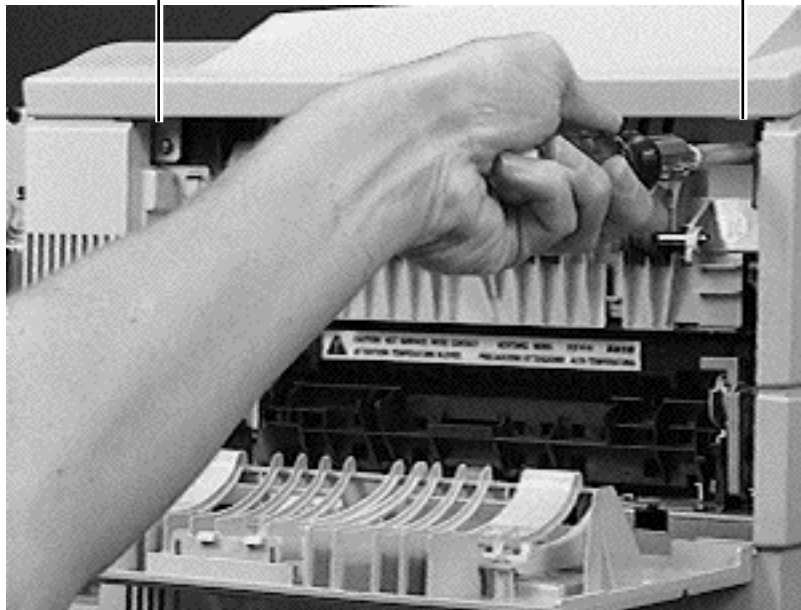



- 2 Using a small flat-blade screwdriver, release the four flex tabs at the four locations indicated and separate the liner from the printer.

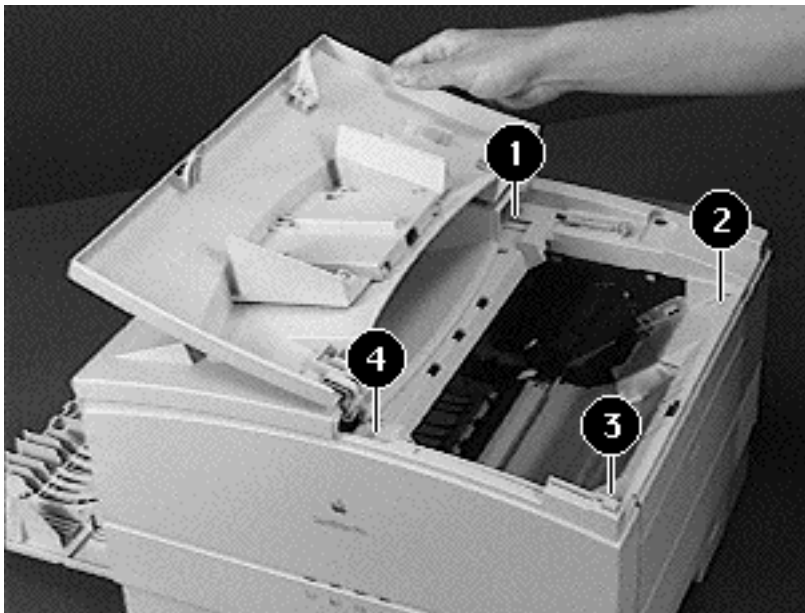



Top Cover

Cover Liner

- 3 Remove the top cover and cover liner from the printer.





**Replacement Note:**

When you reseat the top cover and cover liner, reach through and gently press the delivery surface until the levelling pin pops into place.



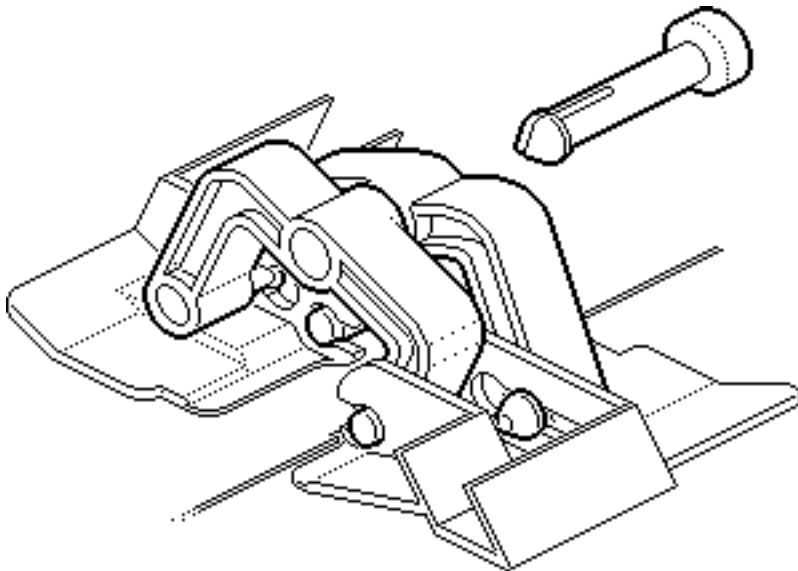

**Replacement Note:** The two hinge assemblies are identical and are fully interchangeable. The components are also universal (that is, each of the four arms, four housings, and two pins are identical.) The illustration shows the hinge assembly in its correct intact state with the pin exploded out for clarity.







## Front Panel

Before you begin, remove the following:

- Rear panel
- Top cover

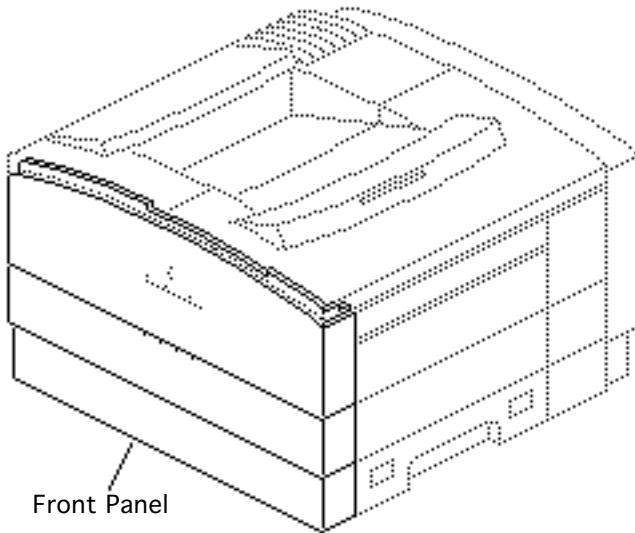

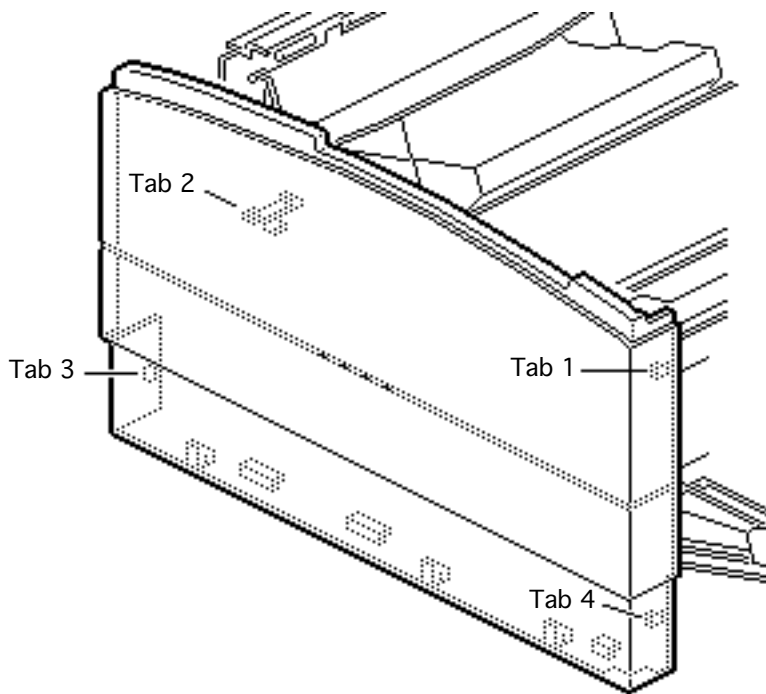

**Note:** The front panel is secured to the printer by three fixed wrap-around tabs (1, 3, 4), one flex tab (2), and six positioning tabs and blocks along the base. The following pages describe the order of tab release.



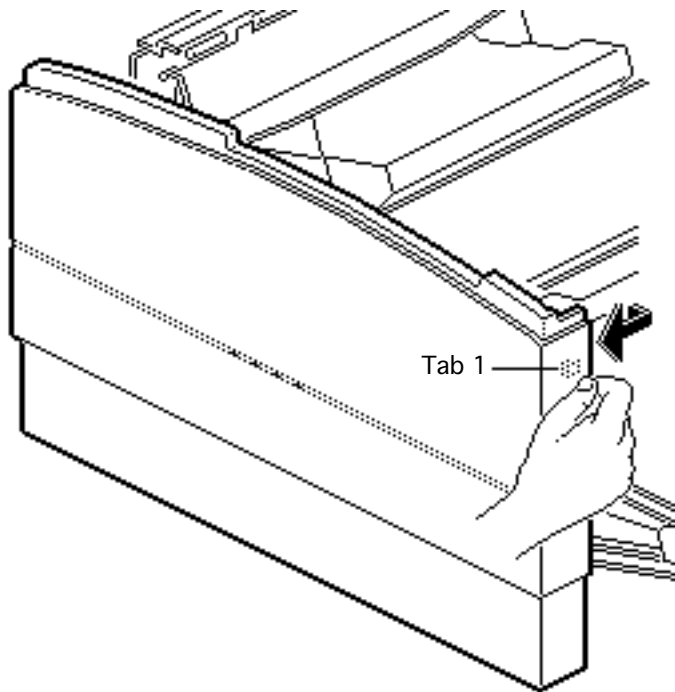

### Releasing Tab 1

- 1 Grasp the front panel with your fingertips and pull it outward slightly to release the upper fixed tab on the right side.



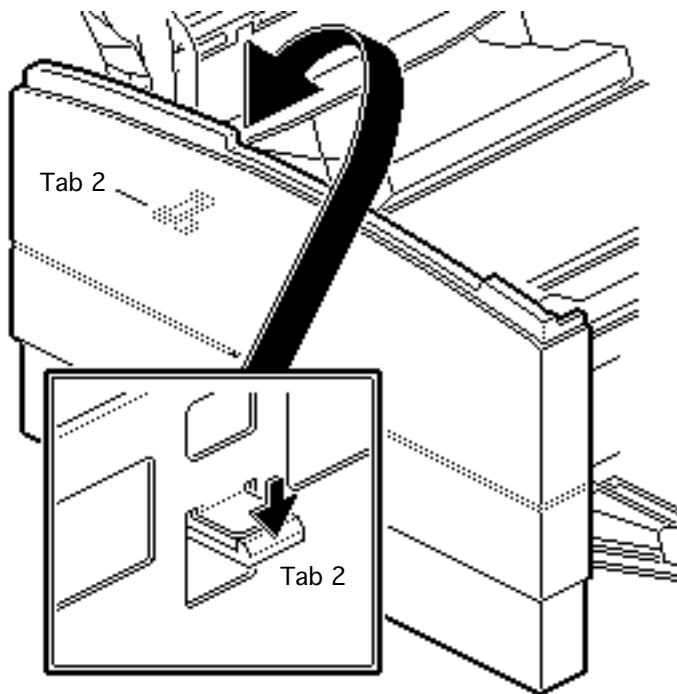

### Releasing Tab 2

- 2 Reach behind the front panel and release the flex tab that secures the front panel to the chassis.



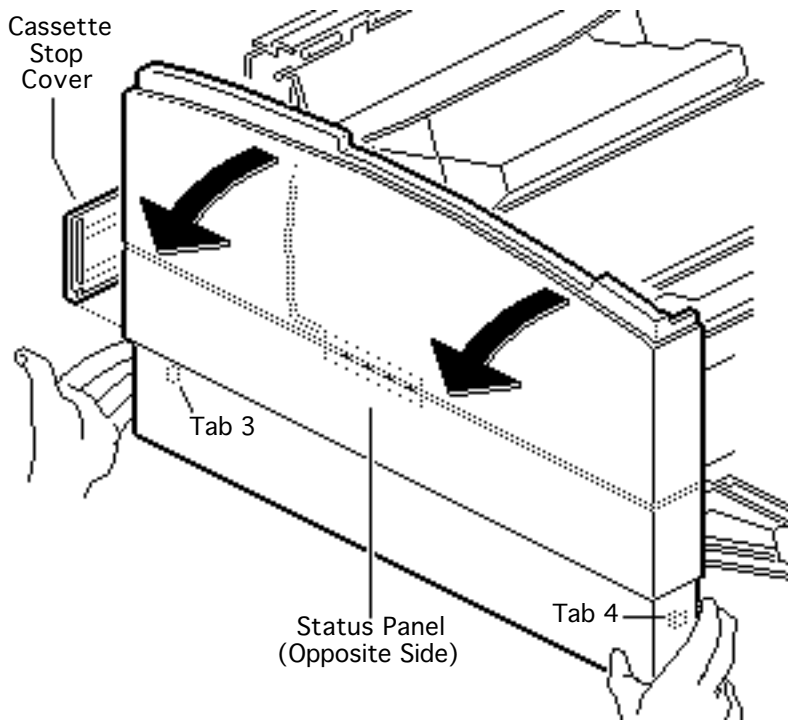

### Releasing Tabs 3 and 4

- 3 Remove the cassette stop cover.
- 4 **Note:** The status panel will still connect the chassis to the front panel after you perform the following step.

Grip the bottom-left and bottom-right corners with your fingertips, release tabs 3 and 4, and swing the front panel downward.



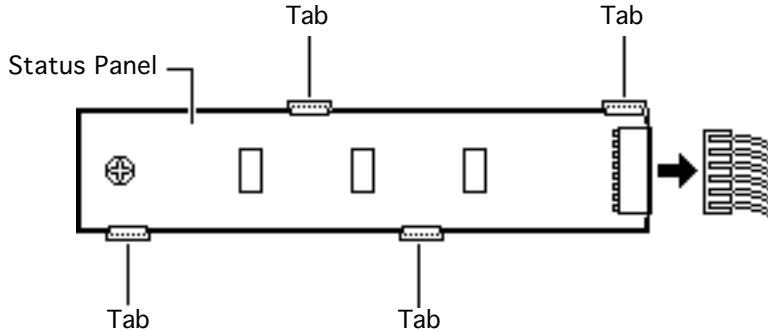

- 5 If you need to have functional LEDs after you remove the panel, don't disconnect the connector. Simply release the tabs and lift off the whole status panel.

If you don't need functional LEDs, disconnect the cable from the status panel connector and remove the front panel.





## I/O Shield

Before you begin, remove the rear panel.

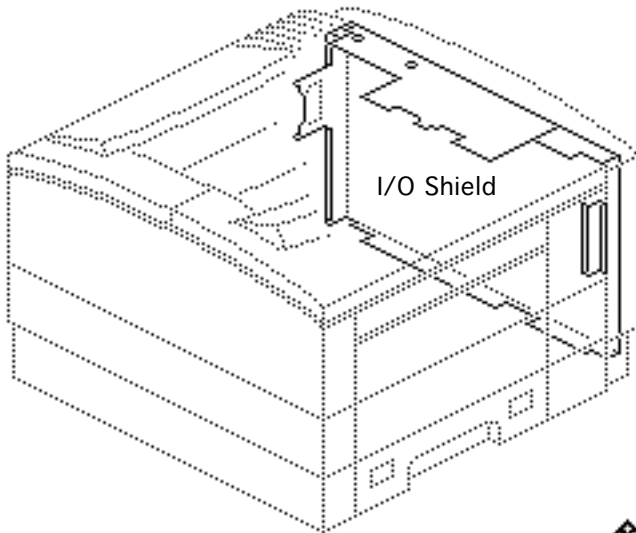

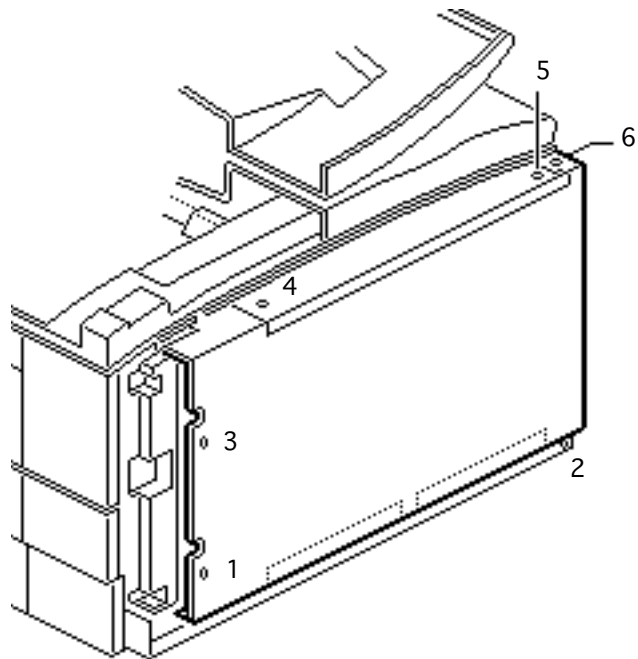

- 1 Remove the six screws in the order shown.

**Replacement Note:**  
Tighten screw 1 first and screw 2 second, then tighten the remaining screws.







- 2 Slide out the I/O shield cover plate.

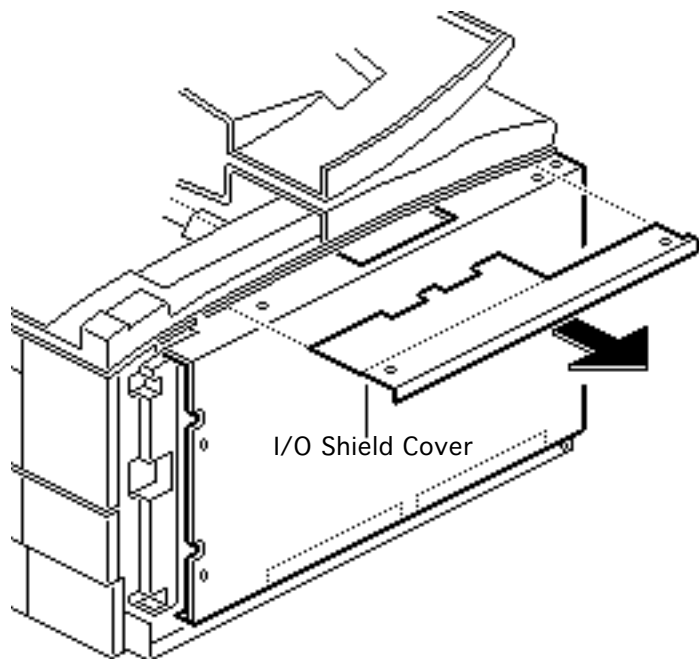

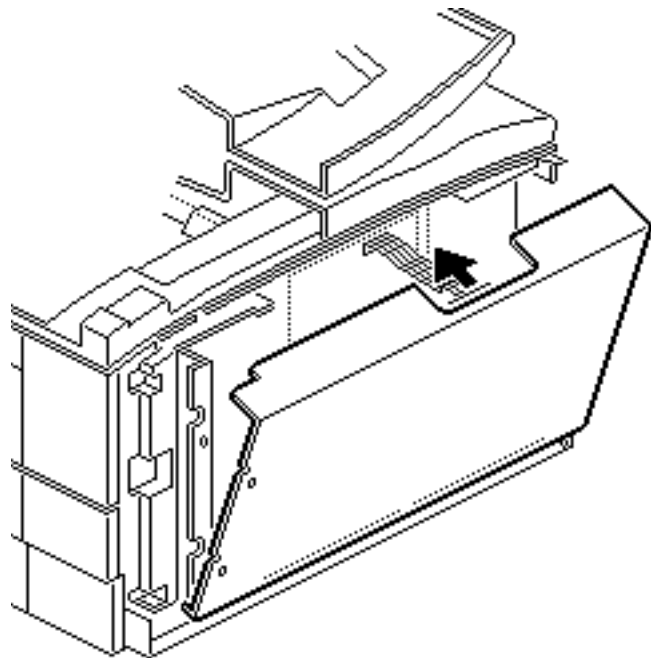

- 3 Swing the I/O shield downward as far as it will go.
- 4 Disconnect the engine interface cable from the I/O board.



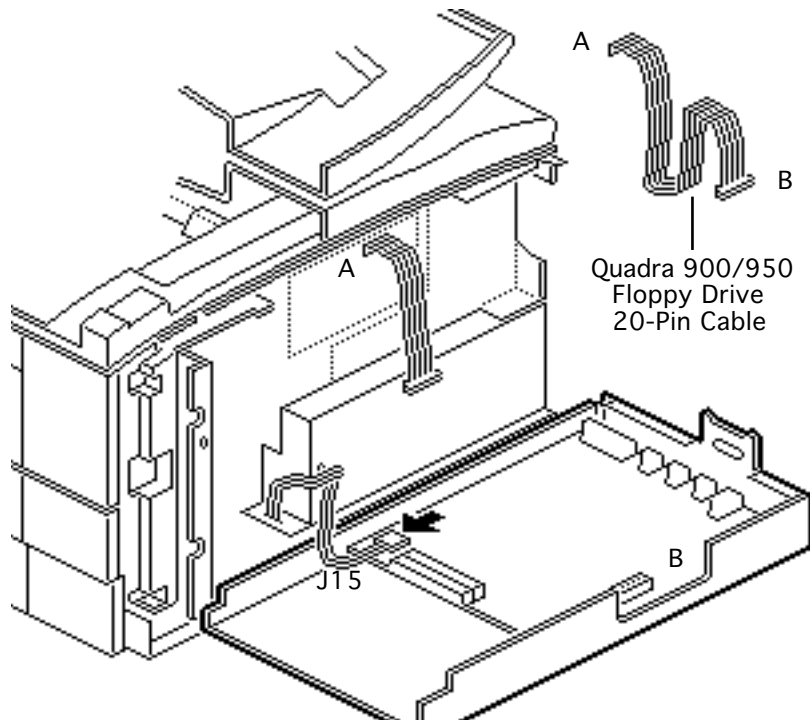

- 5 Swing the I/O shield all the way down and rest it on your work surface.

**Note:** If you need to maintain I/O board connectivity while troubleshooting, remove the printer interface cable and temporarily install a Quadra 900/950 floppy drive 20-pin cable between A and B. This cable has the extra length needed for the I/O shield to rest flat on the work surface.





- 6 Disconnect the power supply cable from connector J15 on the I/O board.

**Replacement Note:** The grounds at the bottom of the shield should rest on top of the chassis flange.





## I/O Board

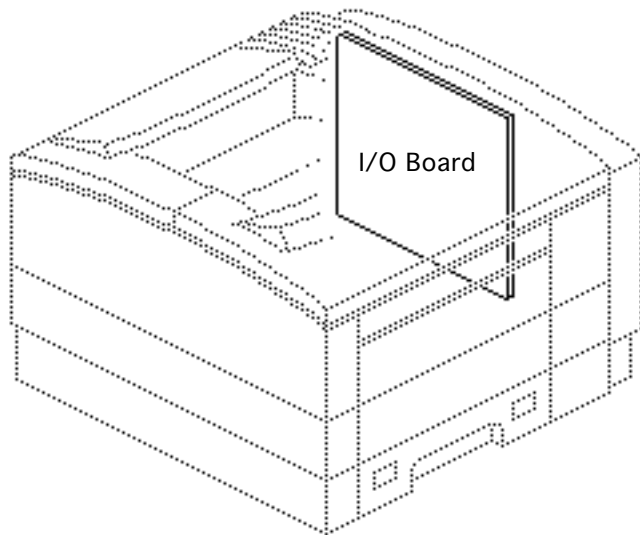

Before you begin, remove the following:

- Rear panel
- I/O shield

**Note:** This topic covers removal and replacement of a defective I/O board. Do not detach the I/O board from the shield if you are performing an upgrade. See Additional Procedures for upgrade information.

**Note:** If the I/O board is removed from the printer,



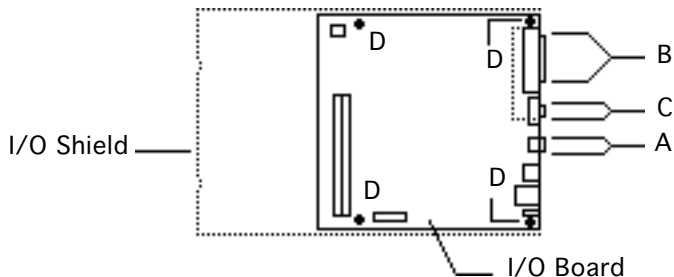
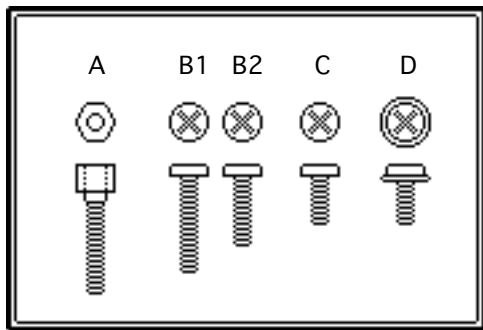

the LEDs no longer function.

- 1 Remove the screws that secure the I/O connectors to the I/O shield flange.

**Note:** Screw C goes to the Ethernet connector and is not present on the LaserWriter Pro 600 board.

**Replacement Note:** A LaserWriter Pro 600 or 630 I/O board may contain one of two versions of the Centronics connector. The two versions use



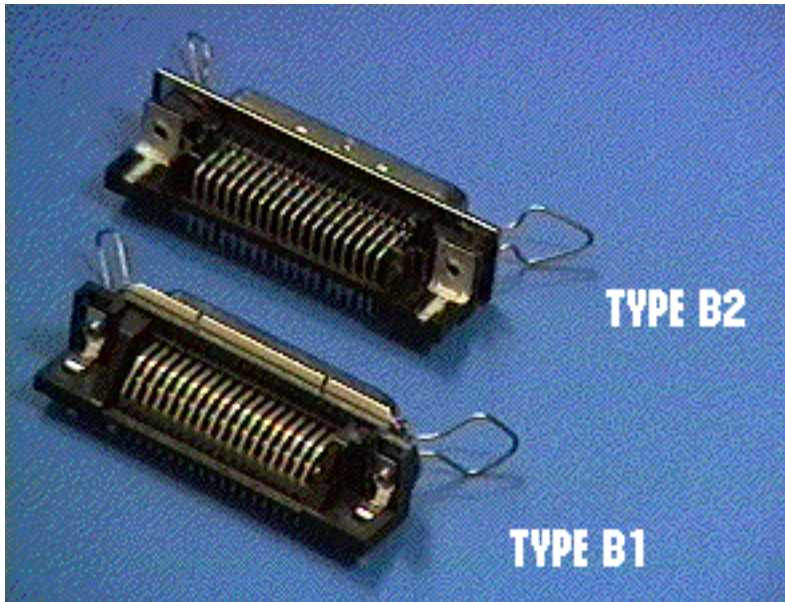

different screws that are not interchangeable (B1 or B2). You must use the correct B-type screw otherwise you will strip the connector.

- 2 Remove the four screws (D) that secure the board to the shield and lift the board off the shield.



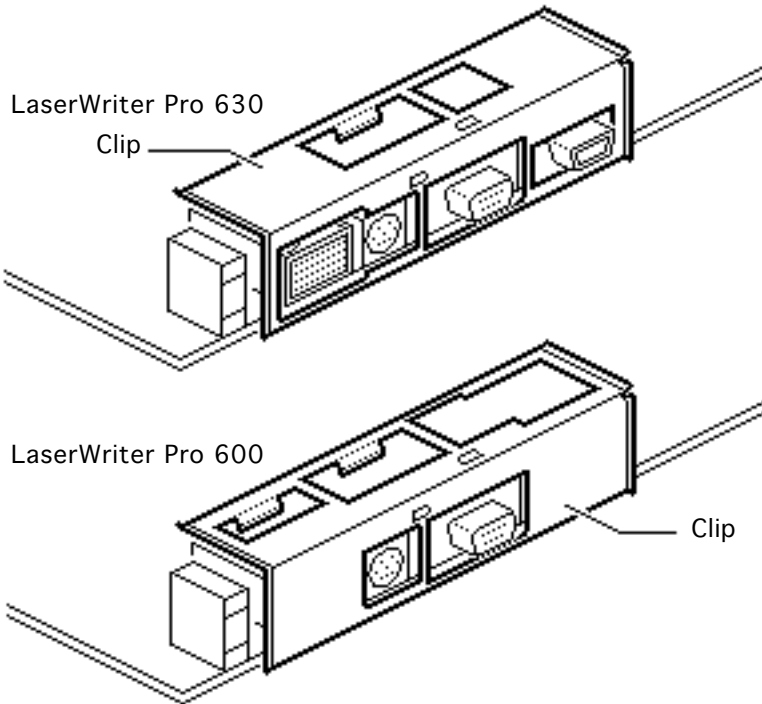

- 3 Remove the sheet metal clip from the connector end of the I/O board.

**Replacement Note:** This clip fits both the LaserWriter Pro 600 and 630 boards. For the LaserWriter Pro 630 board, install the clip so that all four I/O connectors line up with the openings in the sheet metal. For the LaserWriter Pro 600 board, which has no SCSI or Ethernet connector, you must install the clip







so that it covers the SCSI and Ethernet slots.

**Note:** Remove the SIMMs before returning a defective I/O board to Apple.





## Right Corner Panel

Before you begin, remove the following:

- Rear panel
- Top cover

- 1 Remove the two screws that secure the right corner panel to the chassis.

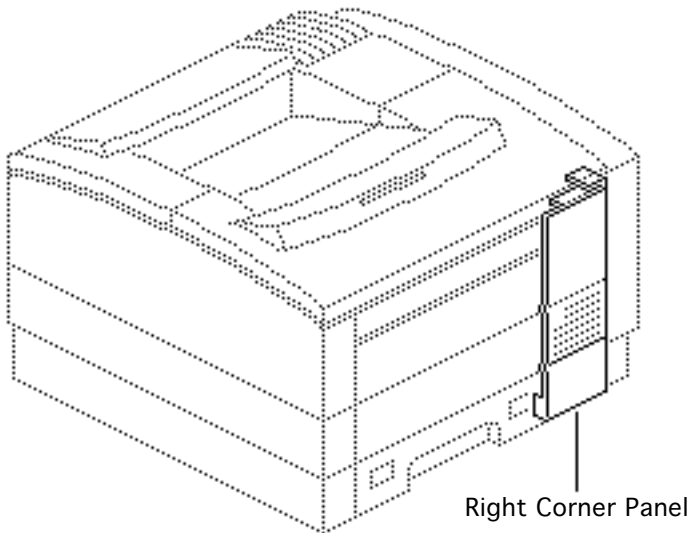

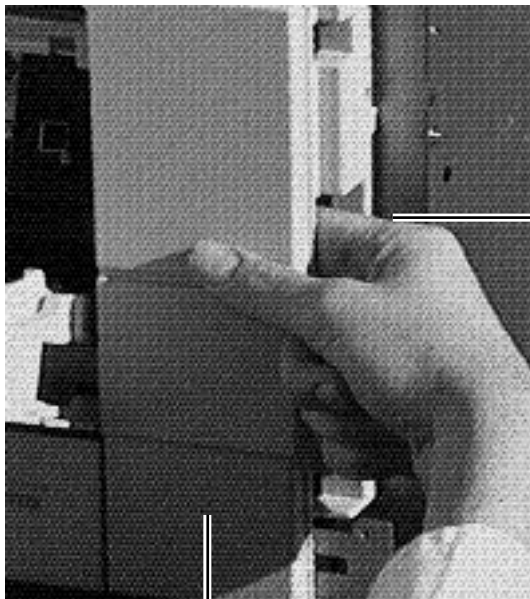

Access Hole

Right  
Corner  
Panel

- 2 Reach into the access hole as shown in the photo at the left, and release the hidden flex tab.
- 3 Remove the right corner panel from the printer.





## Multipurpose Tray Assembly

Before you begin, remove the following:

- Paper cassette
- Rear panel
- Top cover
- Right corner panel
- Front panel

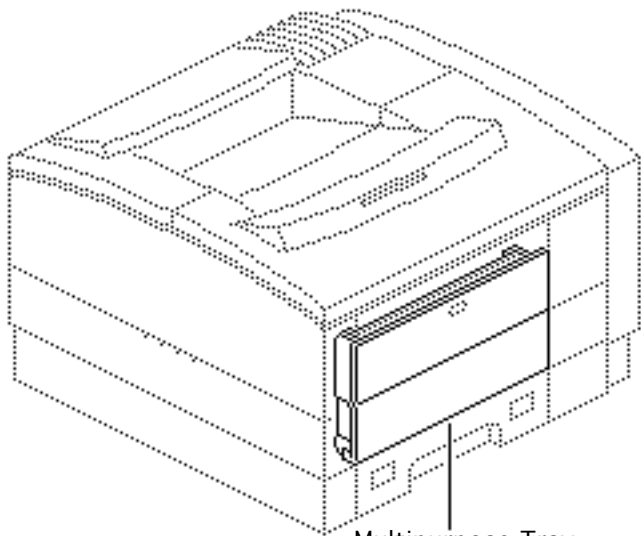

Multipurpose Tray Assembly



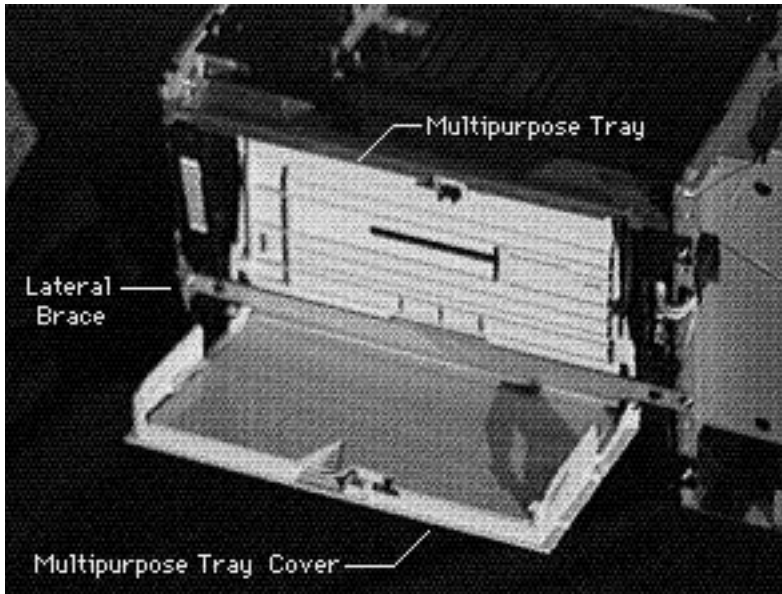

- 1 Push on the rounded recess at the top of the tray cover and open the multipurpose tray.
- 2 Bend the edge guide outward and release the left pin and then the right pin. Tilt the tray up into its normal closed position.

**Note:** The tray cover and extension guide should now be in an open position as shown in the photograph at the left.





- 3 Grasp the sides of the cover and bend the center with your thumbs until the cover pops loose from its pin hinges. Remove the multi-purpose tray cover from the printer.
- 4 Remove the two screws and lift off the lateral brace.
- 5 Open the multipurpose tray until it angles downward and slide the tray off the holding pins.





## Multipurpose Closure Panel

No preliminary steps are required before you begin this procedure.

**Note:** The user removes this panel prior to installing the envelope feeder.

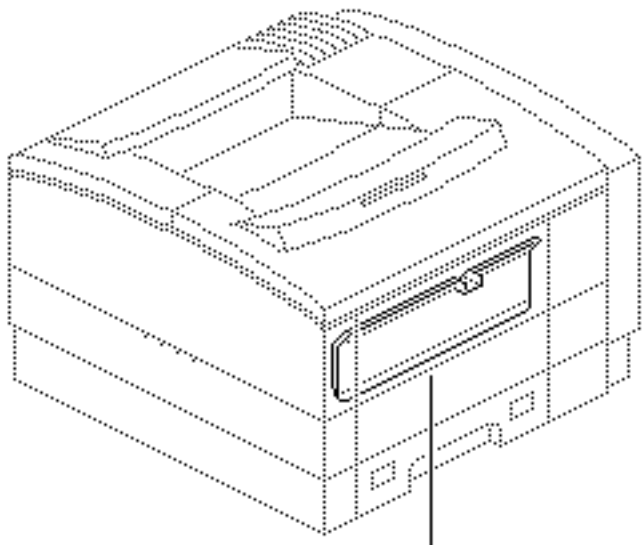

Multipurpose Closure Panel





- 1 Open the multipurpose tray cover by pressing on the cover and letting it drop into feed-ready position.





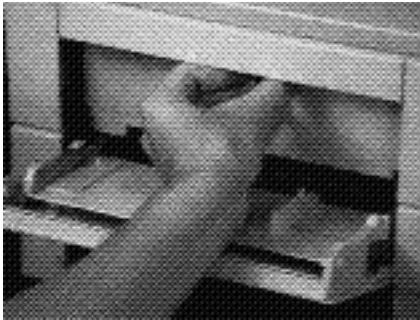

- 2 Grasp the squared notch at the top of the panel between your thumb and forefinger, press down slightly, and lift out the panel.





## Fuser Access Door

No preliminary steps are required before you begin this procedure.

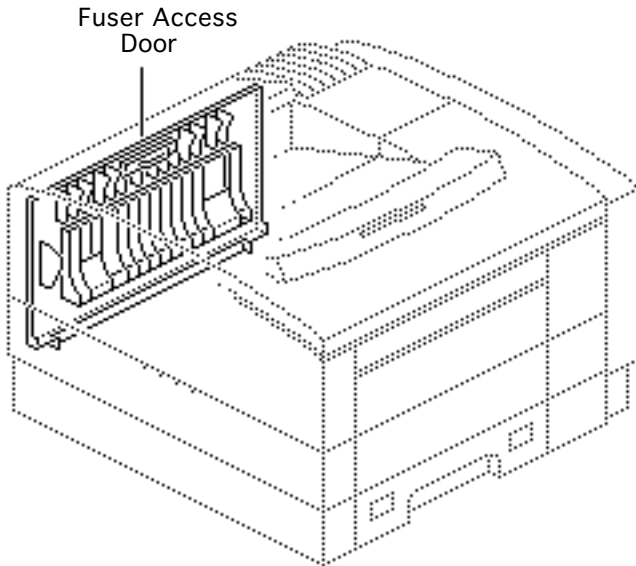

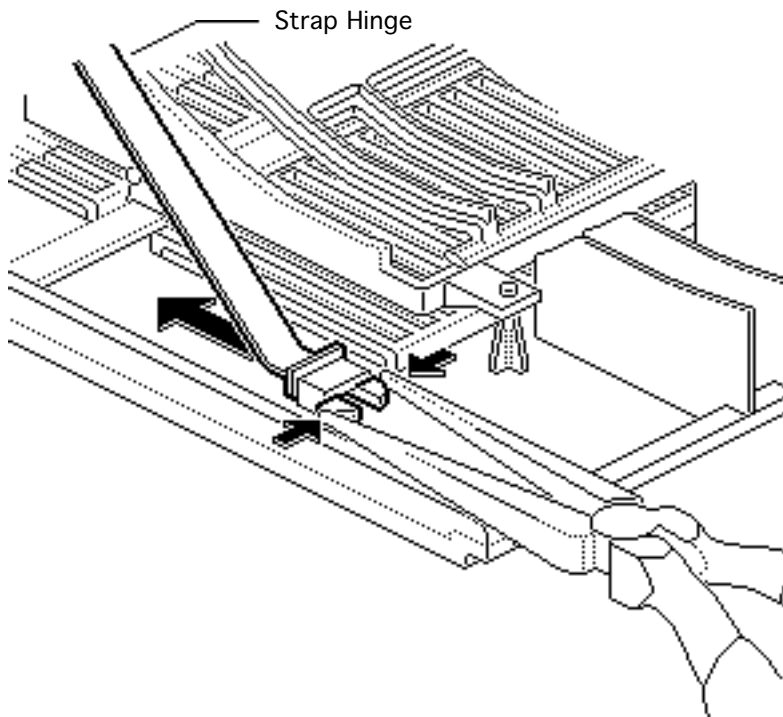

- 1 Open the fuser access door.
- 2 Using needle-nose pliers, squeeze the flex-tab end of the strap hinge and remove the hinge from its mount.





- 3 Grasp the sides of the door and bend the center with your thumbs until the door pops loose from its pin hinges.

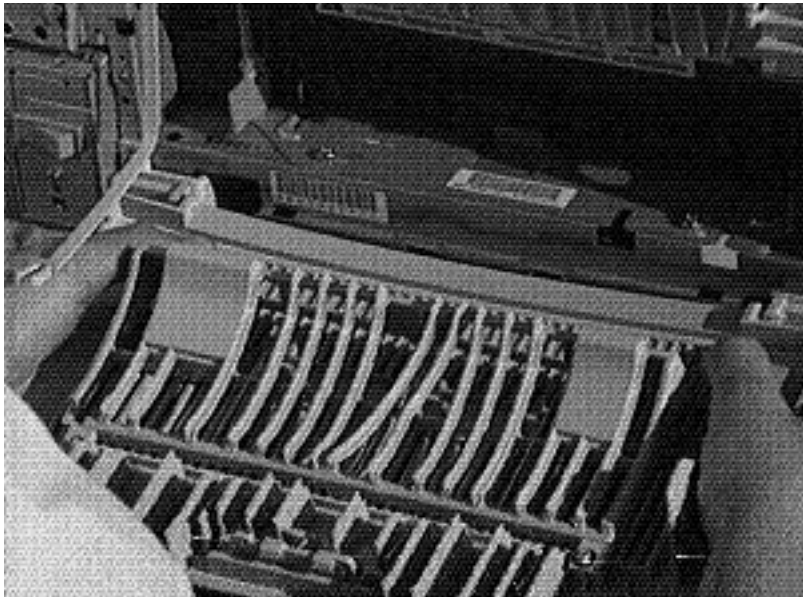



## Fuser Assembly

No preliminary steps are required before you begin this procedure.

**Note:** Refer to the following take-apart topics for further disassembly of the fuser assembly:

- Fuser Cable Cover
- Left Fuser Cover Cap
- Left Fuser Cover
- Fuser Connector Cable
- Fuser Thermoprotector
- Right Fuser Cover
- Fuser Heater Bulb
- Upper Fuser Frame

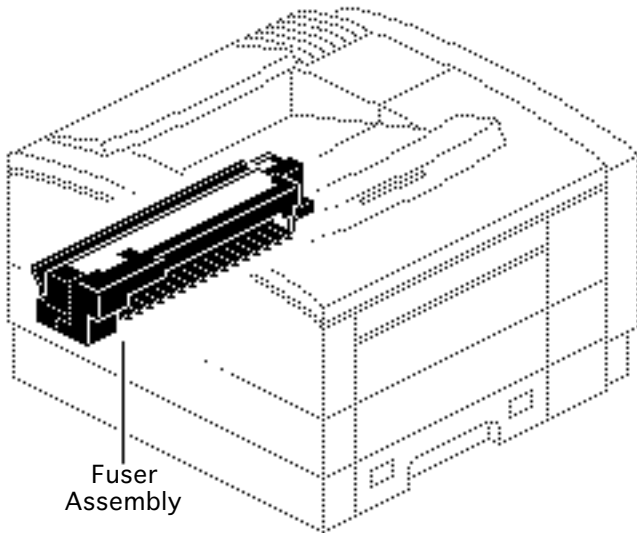



- Fuser Thermosensor
- Delivery-Sensing  
Lever

**Note:** Unless noted otherwise, left and right are defined by viewing the printer through the fuser door opening.



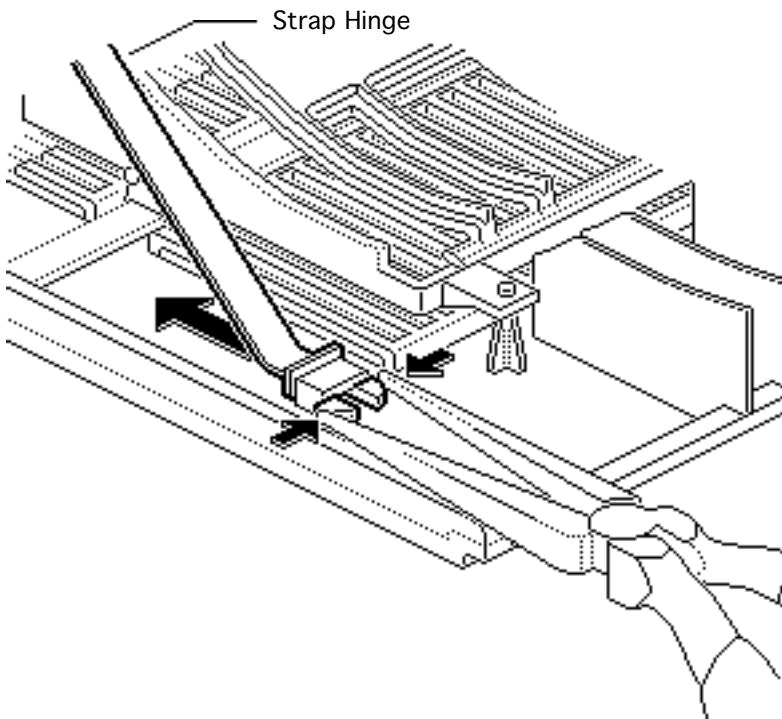

- 1 Open the fuser access door.
- 2 Using needle-nose pliers, squeeze the flex-tab end of the strap hinge and remove the hinge from its mount.





- 3 Remove the two screws.
- 4 **Note:** There is a receptacle left of center on the rear face of the fuser assembly. The receptacle mates with the high-voltage power supply and may cause slight resistance when you pull out the fuser in the following step.

Raise the fuser slightly to clear the two positioning nibs, press down on the green jam-release arm, and pull out the fuser.







## Fuser Cable Cover

Before you begin, remove the fuser assembly.

**Note:** The fuser cable cover is the black plastic cover on the intake side of the fuser assembly. The yellow caution label is on the surface of this cover.

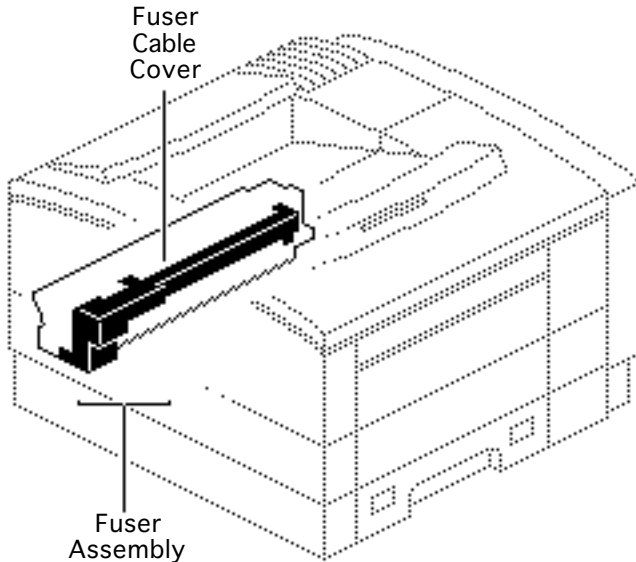

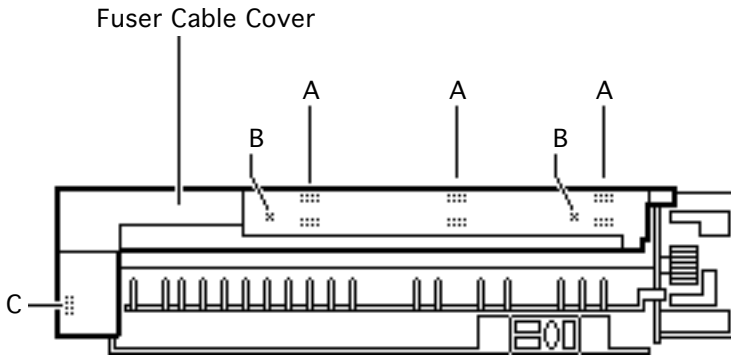

**Note:** The cable cover is secured to the fuser by three pairs of flex tabs (A) and two conical posts (B) hidden behind the yellow label, and by a single flex tab (C) to the left of the entrance guide.

Use a small flat-blade screwdriver to release the flex tabs. Start at the gear end of the fuser and work left.



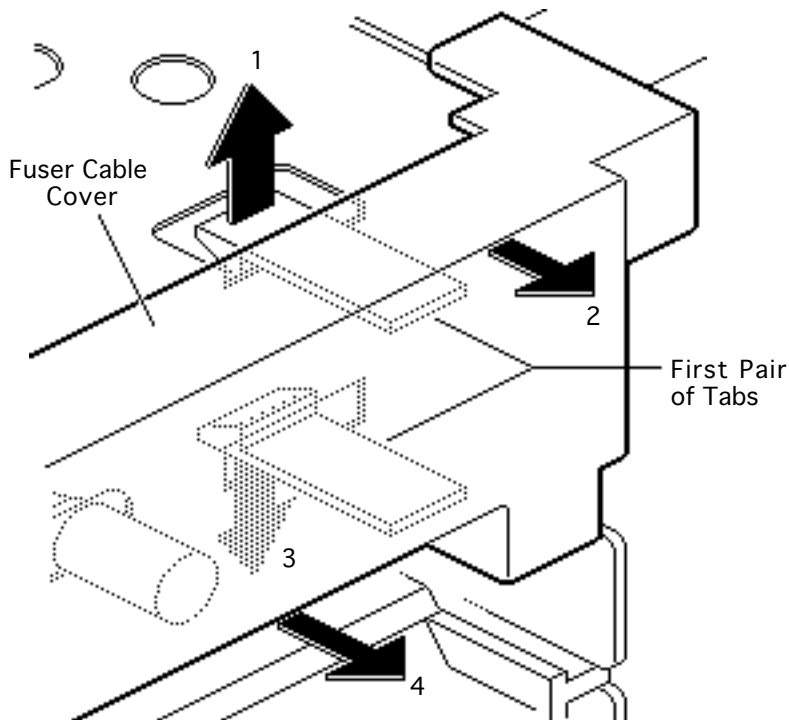

- 1 Release the upper of the first pair of tabs (1) and pull the cover out as far as it will go (2). Then release the bottom tab (3) and pull the cover farther off the fuser assembly (4).
- 2 Repeat this procedure for the next two pairs of flex tabs and remove the cover from the fuser.



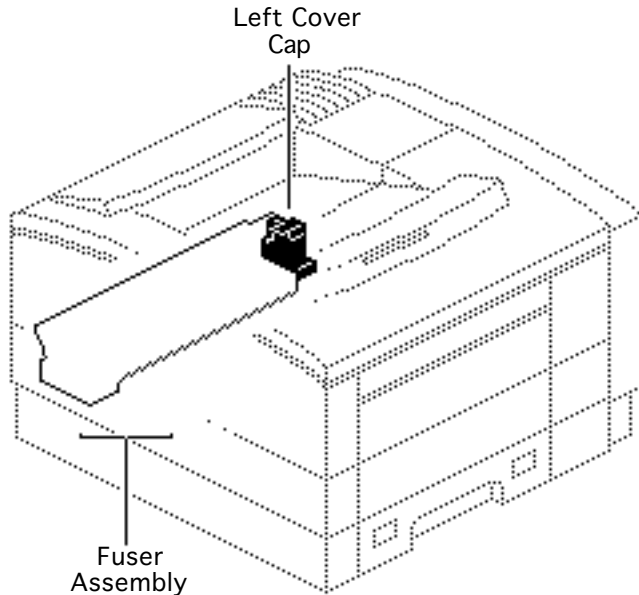

## Left Fuser Cover Cap

Before you begin, remove the fuser assembly.

**Note:** The left fuser cover cap is the black plastic cap on the gear end of the fuser assembly.



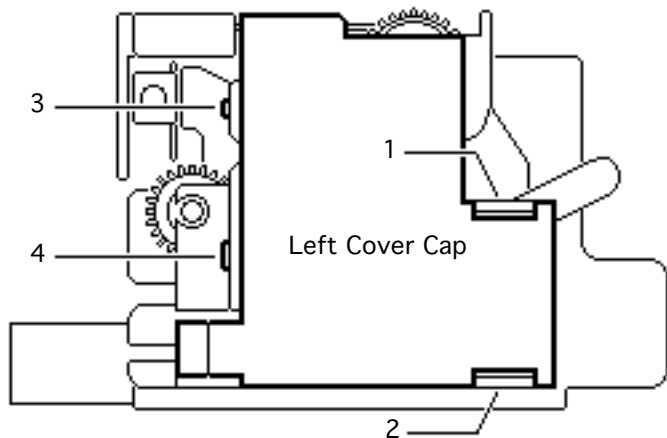

- 1 Release the two flex tabs (1, 2) and pull the cap from the fuser as far as it will go.
- 2 Using a small flat-blade screwdriver, unseat the two fixed tabs (3, 4) and pull the cap off the fuser assembly.



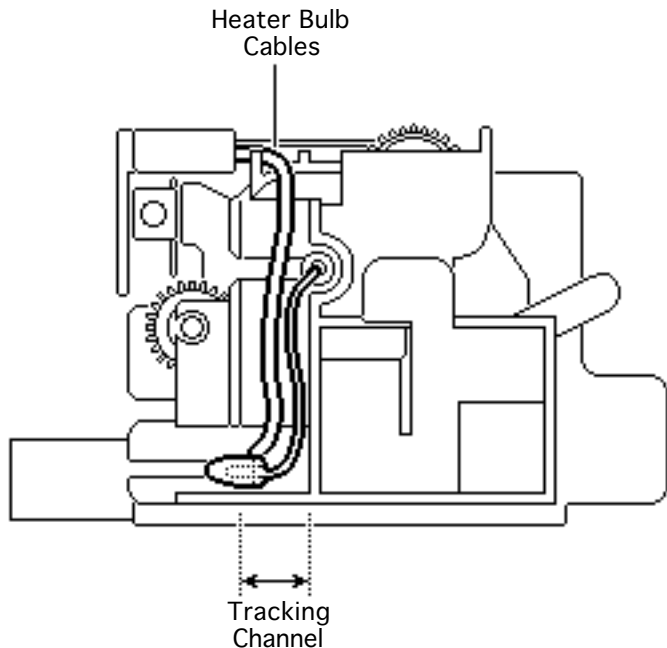

**Replacement Note:** Be sure to press the cables into the tracking channel in the left cover before you replace the cover cap.



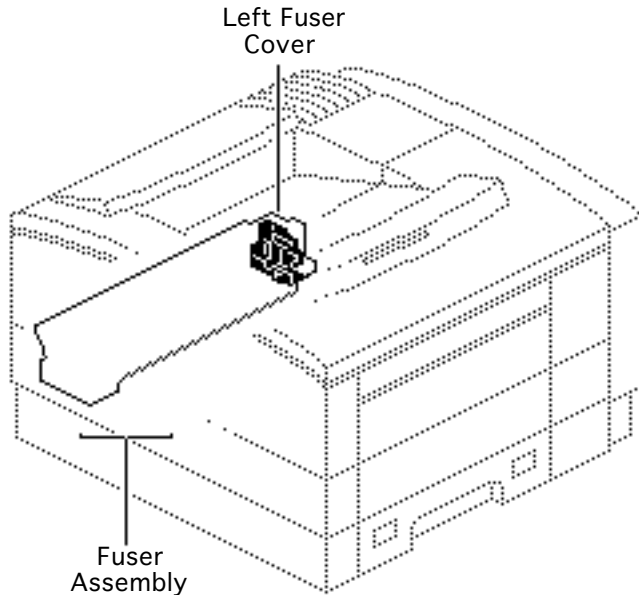

## Left Fuser Cover

Before you begin, remove the following:

- Fuser assembly
- Fuser cable cover
- Left fuser cover cap

**Note:** The left fuser cover is the black plastic cover that sits beneath the cover cap on the gear end of the fuser. The left fuser cover supports the end of the heater bulb and encloses the fuser gears.



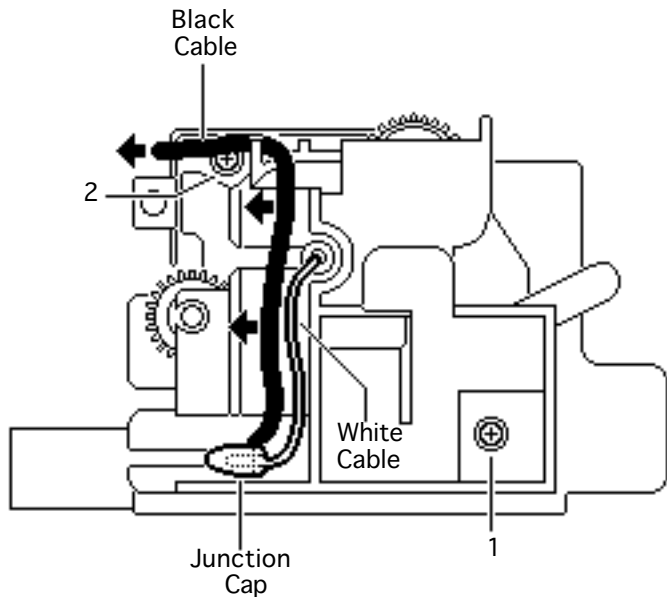

- 1 Remove the two screws (1 and 2).
- 2 Remove the black cable from the channel and disconnect the white cable at the junction cap.





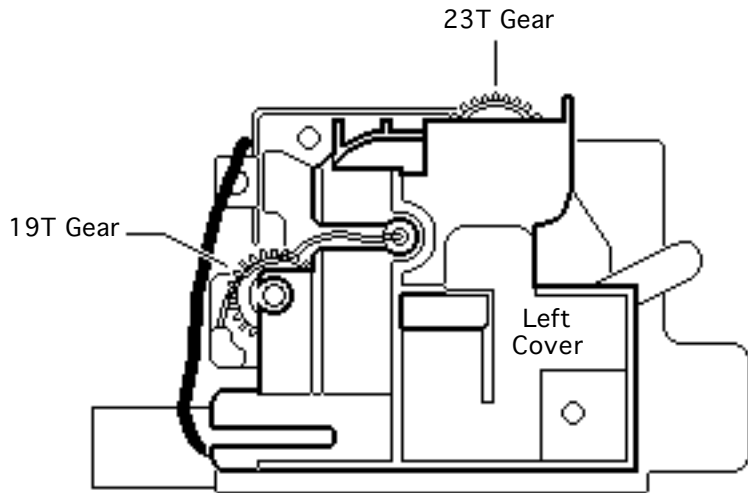

3 Pull off the cover.

**Caution:** The two gears slide off the fuser if you turn the fuser on end. If you are replacing other pieces, remove the gears and set them aside.





## Fuser Connector Cable

Before you begin, remove the following:

- Fuser assembly
- Fuser cable cover
- Left fuser cover cap

**Note:** The fuser connector cable delivers high-voltage power to the fuser bulb and receives temperature feedback from the thermosensor. If you are looking from the feed side of the fuser, the thermosensor circuit goes to the left and

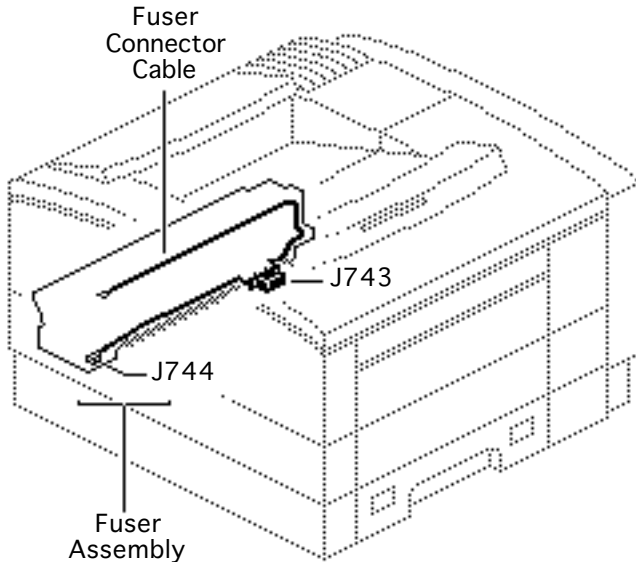

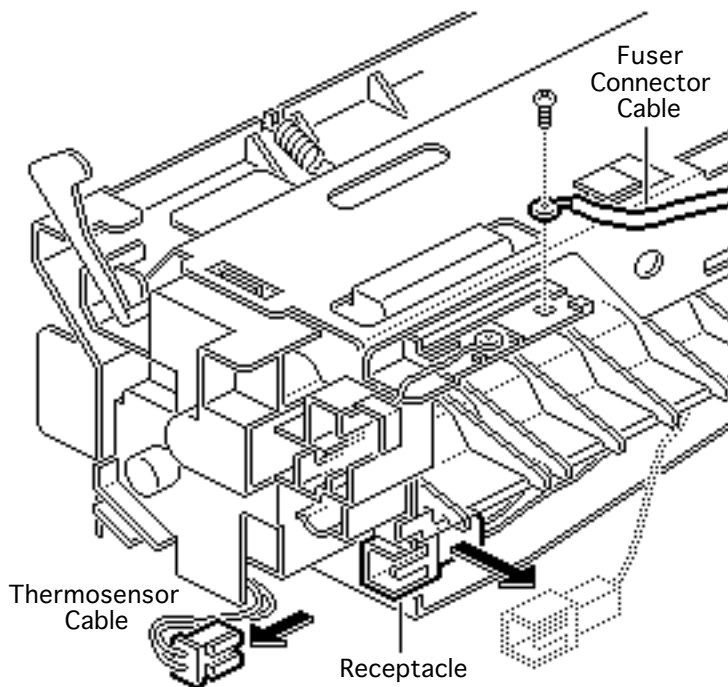

the heater bulb circuit goes to the right.

- 1 Unplug the thermosensor cable and slide the receptacle off the frame.
- 2 Remove the screw that secures the fuser connector cable to the thermoprotector contact.



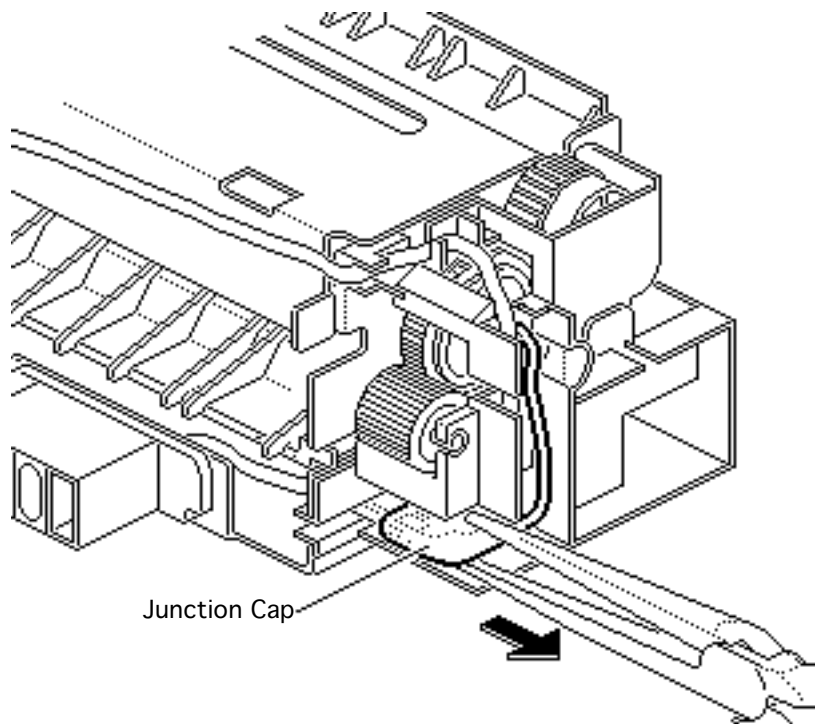

- 3 Disconnect the white heater bulb cable at the junction cap on the gear end of the fuser.



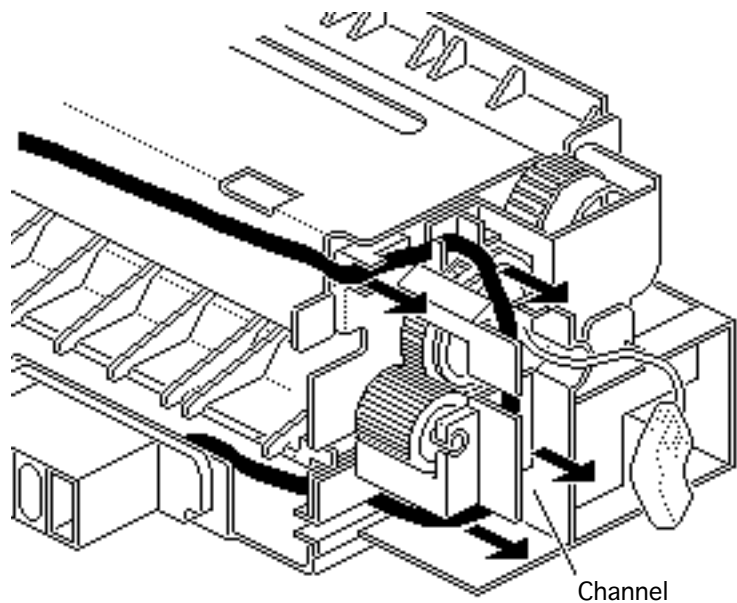

- 4 Remove the fuser connector cable from the channel in the left fuser cover.





- 5 Release the expansion posts behind the receptacle and remove the connector cable from the fuser assembly.

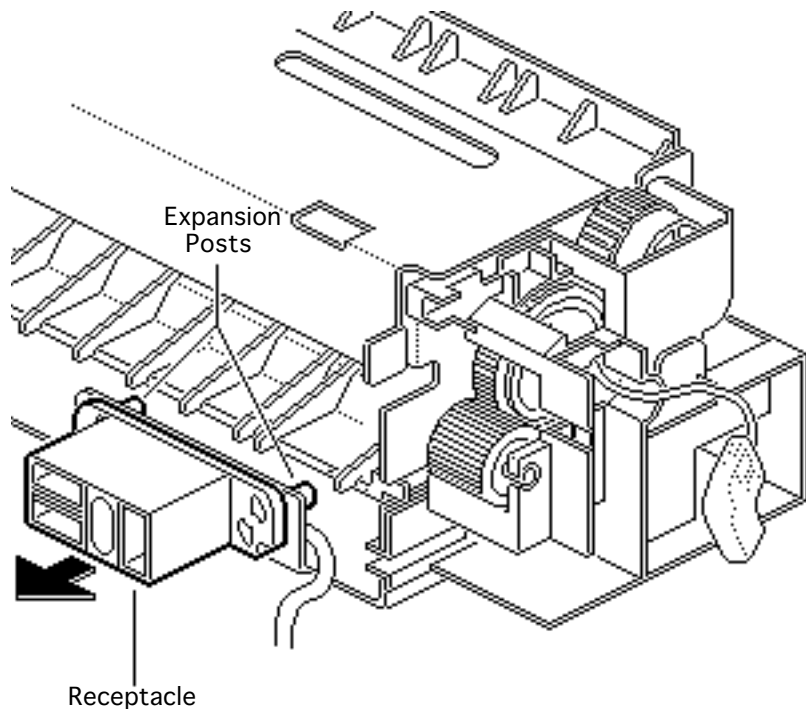



## Fuser Thermoprotector

Before you begin, remove the following:

- Fuser assembly
- Fuser cable cover

**Note:** The fuser thermoprotector prevents overheating of the fuser bulb.

**Caution:** When the thermoprotector has blown, replacing it does not necessarily solve the problem. You must

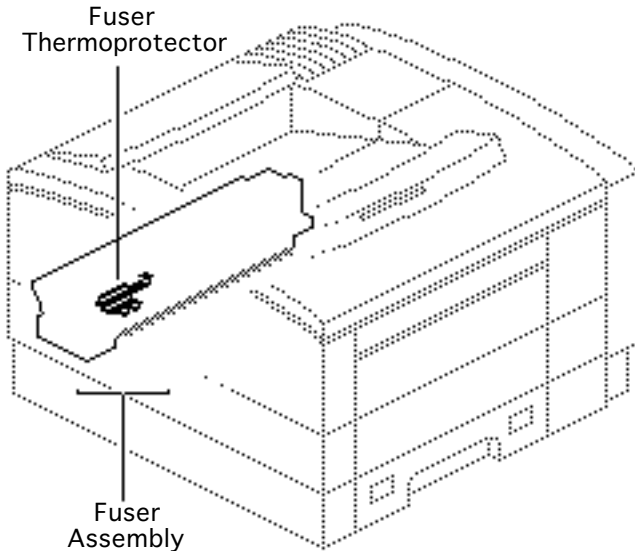

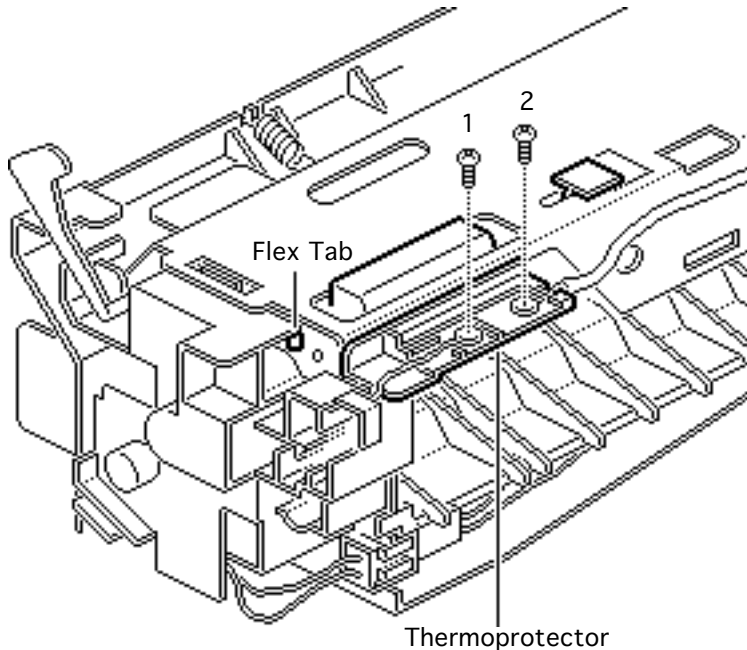

investigate root causes of the overheating.

- 1 Remove the two screws that secure the cables to the thermoprotector contacts.
- 2 Press the flex tab that is visible just under the right cover and pop out the thermoprotector assembly.







## Right Fuser Cover

Before you begin, remove the following:

- Fuser assembly
- Fuser cable cover

**Note:** The right fuser cover is the black plastic cover on the lever end of the fuser assembly. The right fuser cover supports the end of the heater bulb and routes the thermosensor cabling.

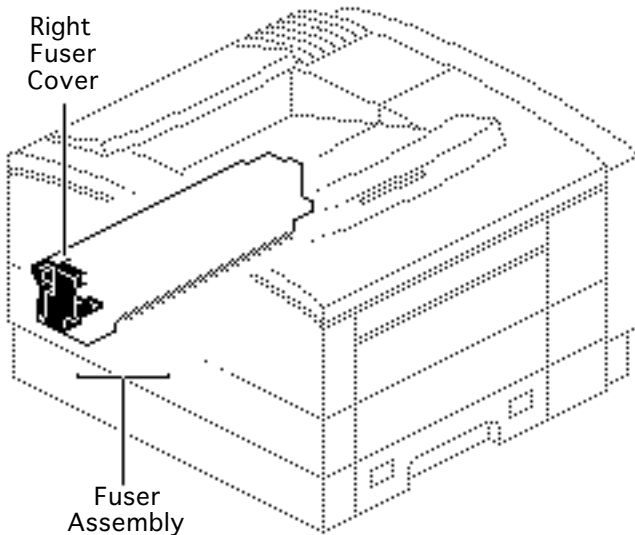

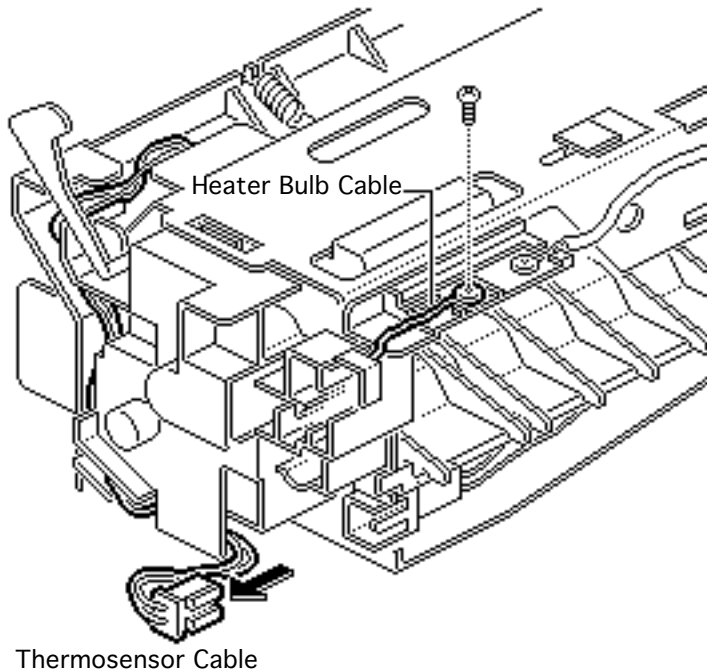

- 1 Unplug the thermosensor cable.
- 2 Remove the screw that secures the heater bulb cable to the thermo-protector contact.



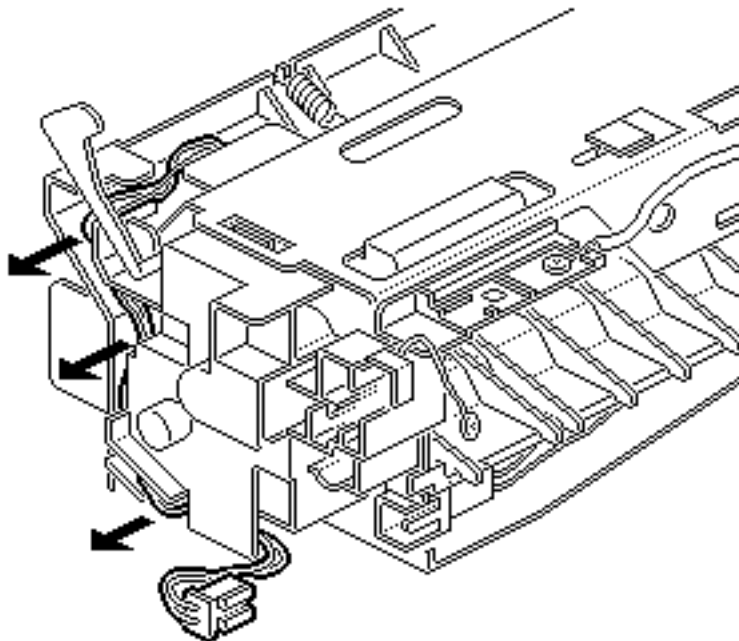

Thermosensor Cable

- 3 Remove the thermosensor cable from the channel in the fuser cover.



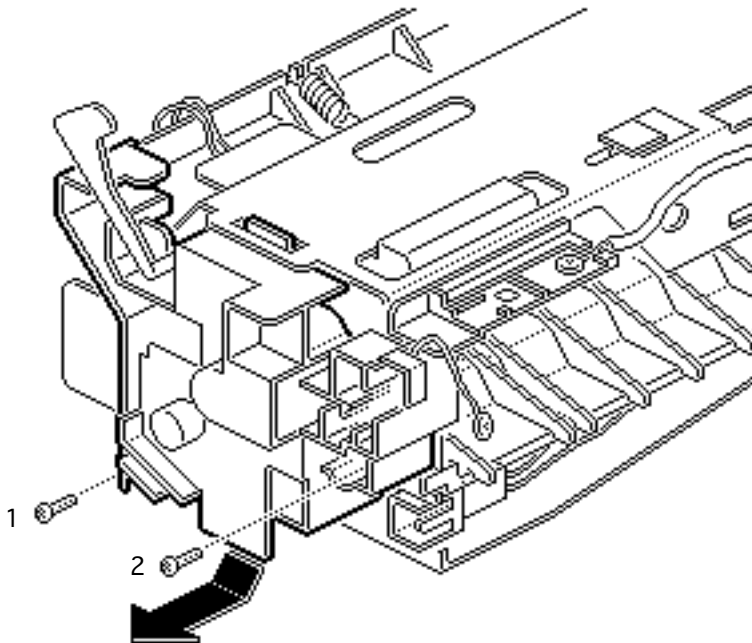

- 4 Remove the two brass colored screws.
- 5 Pull the cover down slightly to unseat it from the upper frame, and lift the cover off the fuser.

**Note:** It may be necessary to pry a bit between the cover and the frame with a small flat-blade screwdriver.

**Replacement Note:** Make sure that the roller release lever is set in place correctly prior to reassembly.





## Fuser Heater Bulb

Before you begin, remove the following:

- Fuser assembly
- Fuser cable cover
- Left fuser cover cap
- Left fuser cover
- Right fuser cover

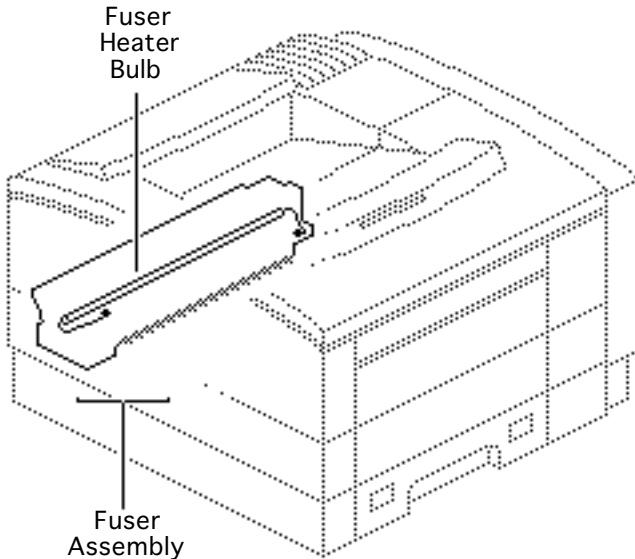



Fuser Heater Bulb

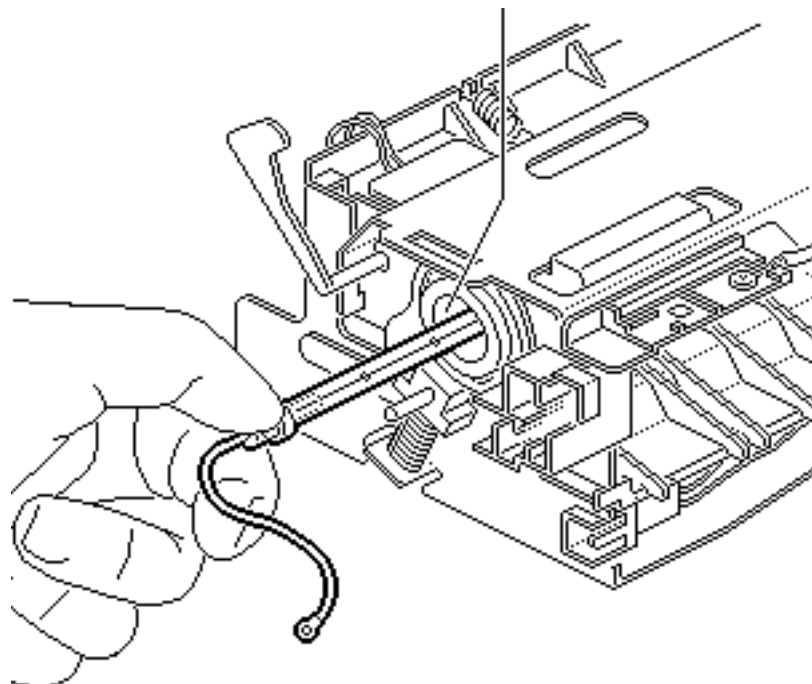

- 1 **Note:** Be careful not to touch the glass part of the bulb with your fingers.

Grasp the left end of the bulb and carefully slide the bulb out of the fuser assembly.





## Upper Fuser Frame

Before you begin, remove the following:

- Fuser assembly
- Fuser cable cover
- Fuser thermoprotector
- Left fuser cover cap
- Right fuser cover

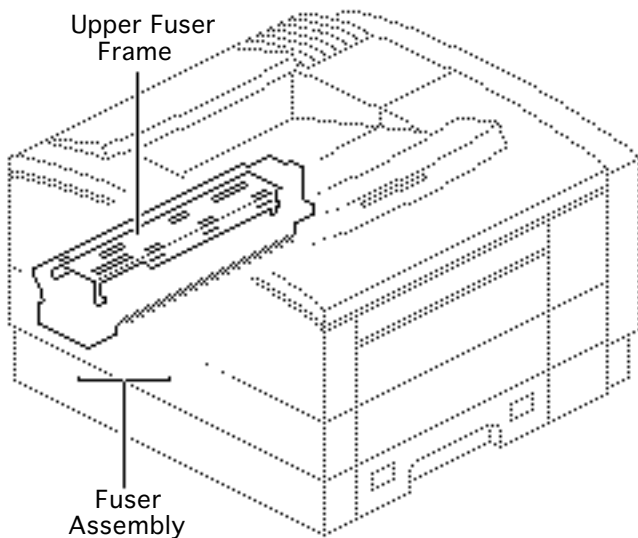

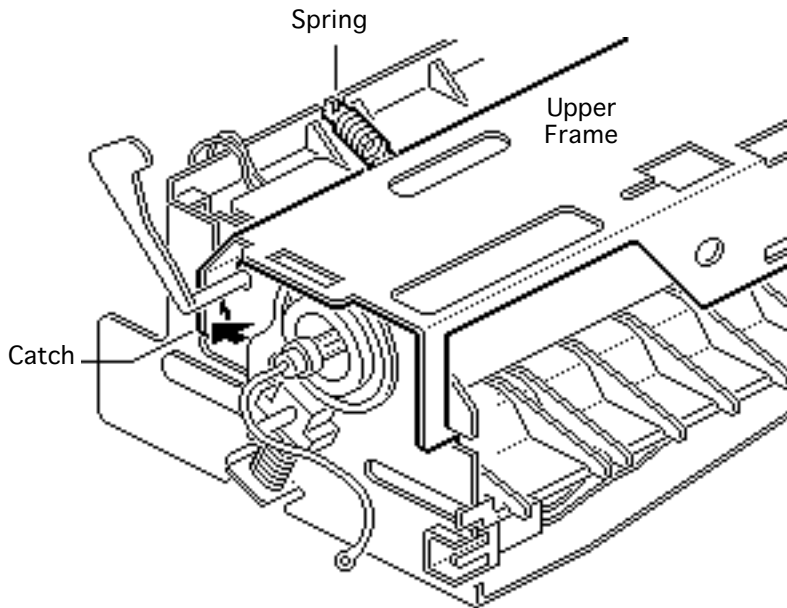

**Note:** In the following steps, only the spring and the catch on the near side are shown in the drawing.

- 1 Remove the two springs.
- 2 Release the catches at each end of the upper frame and lift the frame up and off the fuser assembly.







## Fuser Thermosensor

Before you begin, remove the following:

- Fuser assembly
- Fuser cable cover
- Fuser thermoprotector
- Left fuser cover cap
- Right fuser cover
- Upper fuser frame

**Note:** The thermosensor monitors the temperature of the fuser bulb and relays the temperature back to the DC controller board.

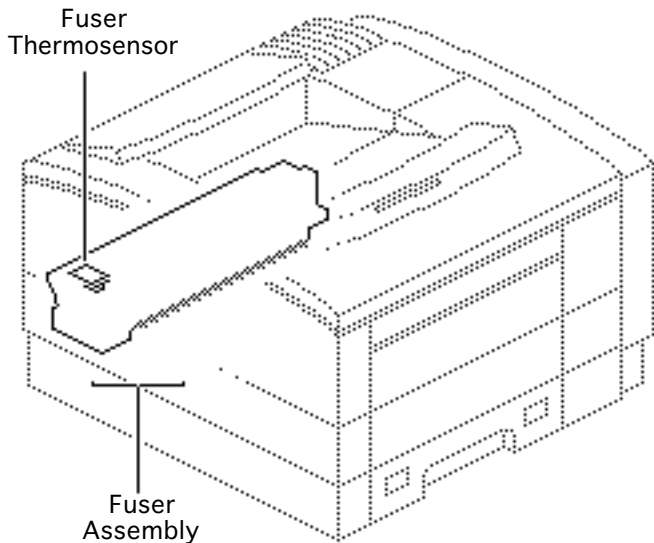

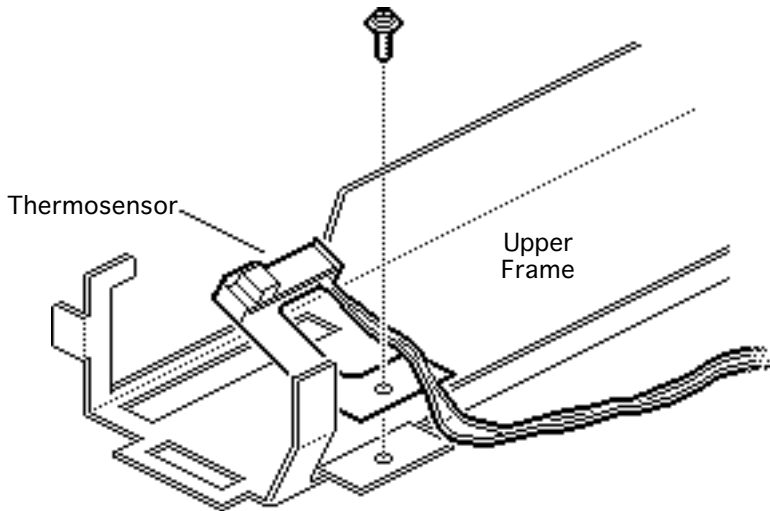

- 1 Remove the screw that connects the thermosensor to the upper fuser frame and lift off the thermosensor.



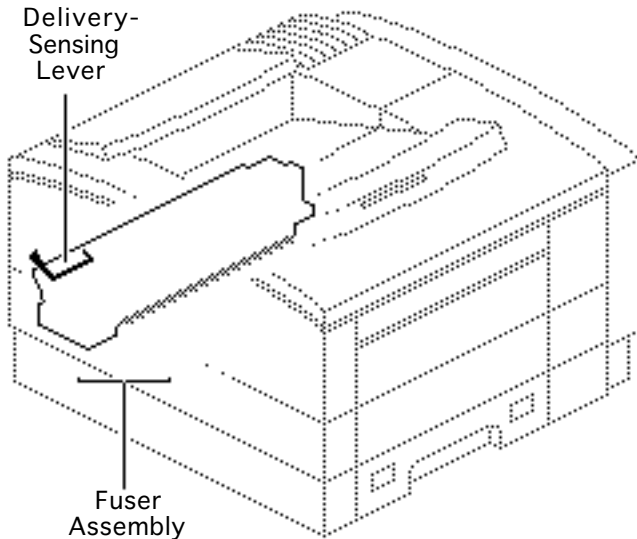

## Delivery-Sensing Lever

Before you begin, remove the following:

- Fuser assembly
- Fuser cable cover
- Fuser thermoprotector
- Left fuser cover cap
- Right fuser cover
- Upper fuser frame

**Note:** Paper exiting the fuser trips the delivery-sensing lever, which in turn opens a photo interrupter in the delivery/interlock sensor assembly. See





“Sensing System Theory” in Basics.

- 1 **Note:** There are two pins at the ends of the separation guide that seat into the frame. Only one end is shown in the drawing.

Using a small flat-blade screwdriver, pry the separation guide off the frame at the gear end of the fuser assembly.

- 2 Lift the separation guide from the fuser assembly.

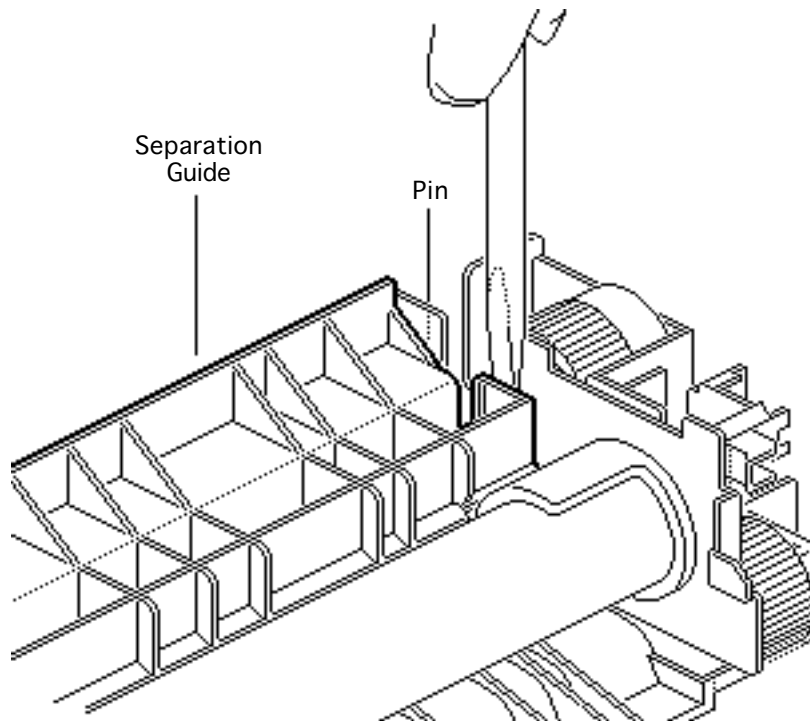



- 3 Snap the lever out of the grip in the separation guide and pull the lever off the post.

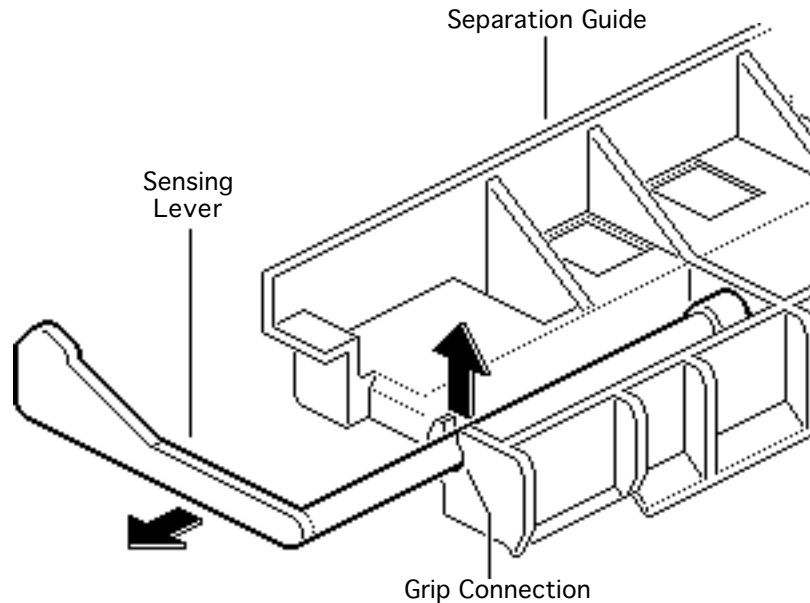



## Delivery Roller Assembly

Before you begin, remove the following:

- Rear panel
- Top cover

**Note:** Refer to the following take-apart topics for further disassembly of the delivery roller assembly:

- Upper Delivery Guide
- Lower Delivery Roller Shaft
- Upper Delivery Roller Shaft
- Delivery Drive Belt

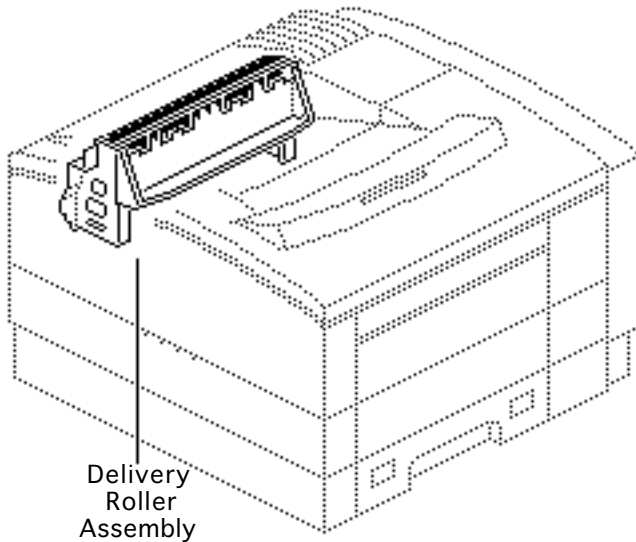



**Note:** The double-roller shaft design yields an S-shaped paper path that handles heavier paper than was possible in previous engines. As a result, there is no face-up delivery tray in the LaserWriter Pro.



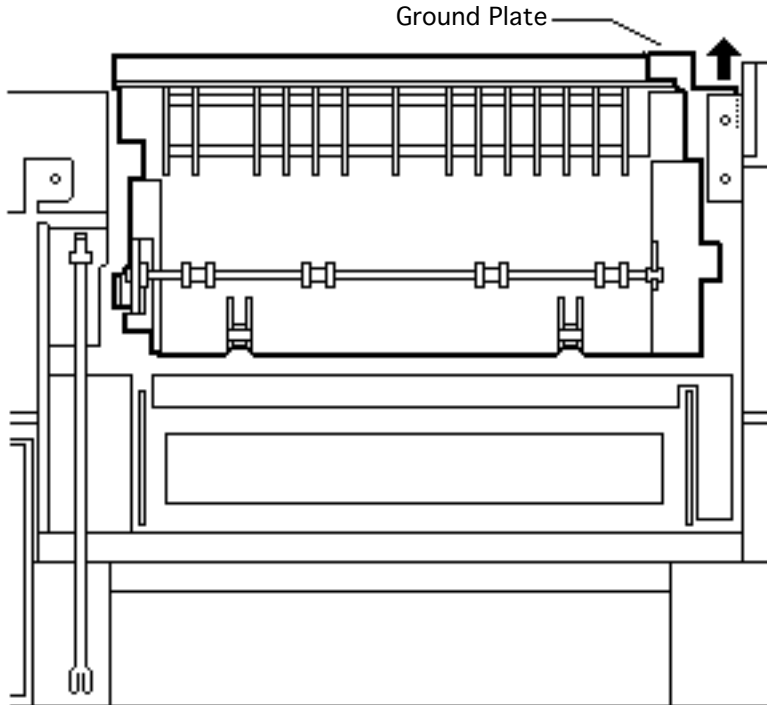

- 1 Disconnect the ground plate from the chassis.







- 2 Place your left hand as shown and press upward on the lower roller shaft.

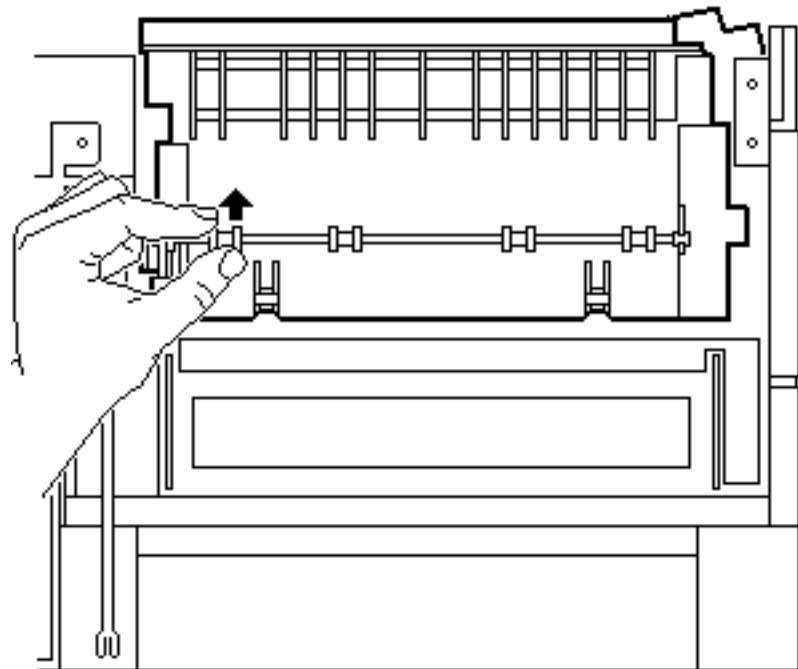



- 3 Using a small flat-blade screwdriver, press in on the left gripper tab (1) and then the right tab (2), and disengage the assembly from the chassis.

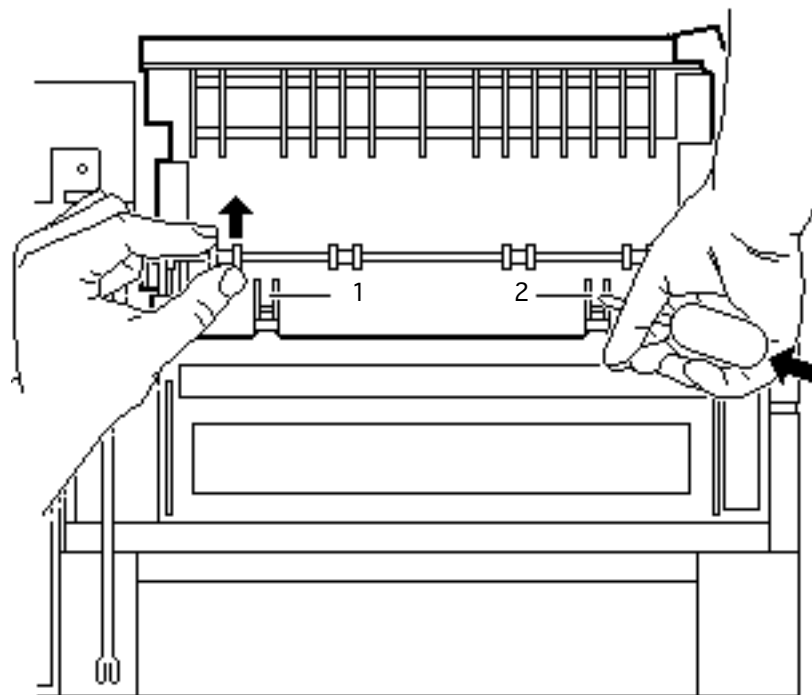



- 4 Place your right hand opposite your left and pull the assembly from the printer, using the rolling motion indicated.

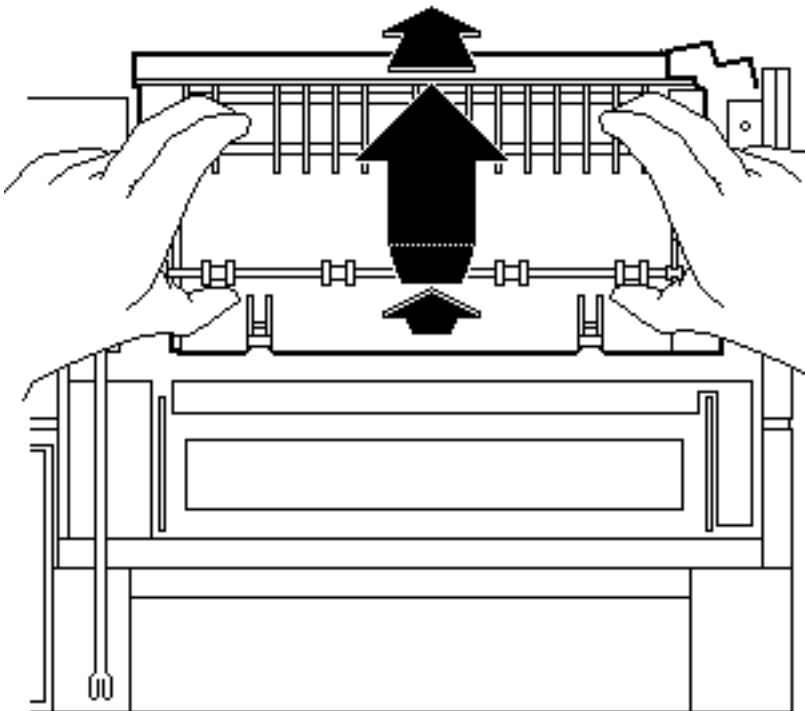

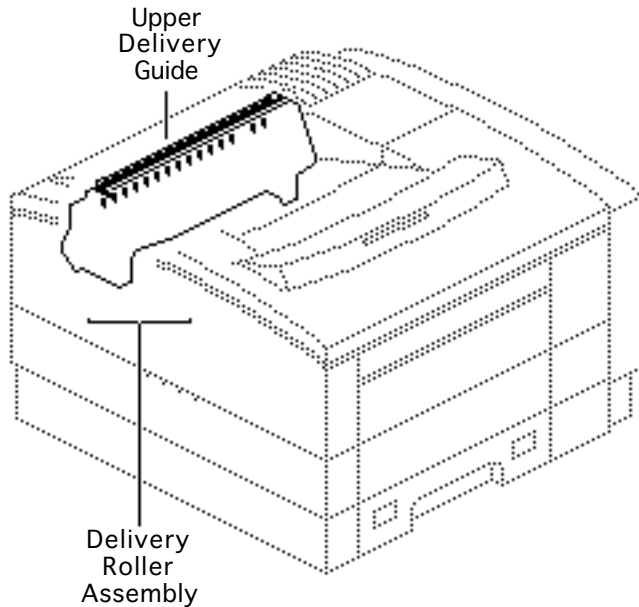

## Upper Delivery Guide

Before you begin, remove the following:

- Rear panel
- Top cover





- 1 Disconnect the ground plate from the chassis.
- 2 Release the flex tab on the right side of the delivery roller assembly and pop the delivery guide free of the upper delivery roller.
- 3 Release the tab and grip on the left side and remove the delivery guide from the delivery roller assembly.



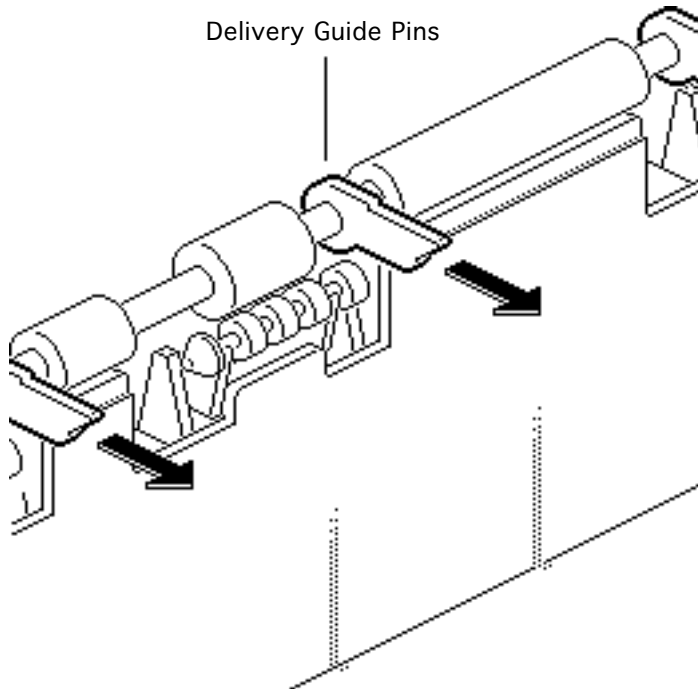

**Replacement Note:** The four small delivery guide pins that hang freely on the upper shaft must point outward (with the flow of paper).



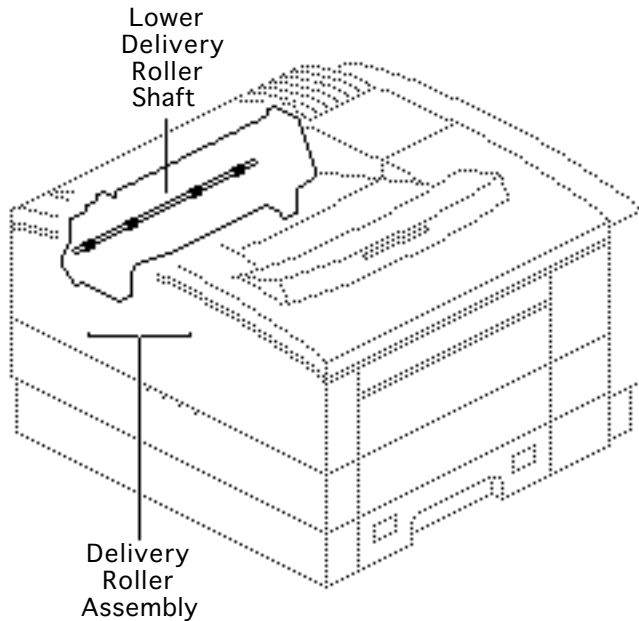

## Lower Delivery Roller Shaft

Before you begin, remove the following:

- Rear panel
- Top cover
- Delivery roller assembly





- 1 Remove the E-ring on the right side of the shaft and slide off the bushing.
- 2 **Caution:** The four lower passive delivery rollers will fall out when you perform the following procedure.

Push the delivery roller shaft to clear the left grip and drive belt and lift the shaft from the delivery roller assembly.





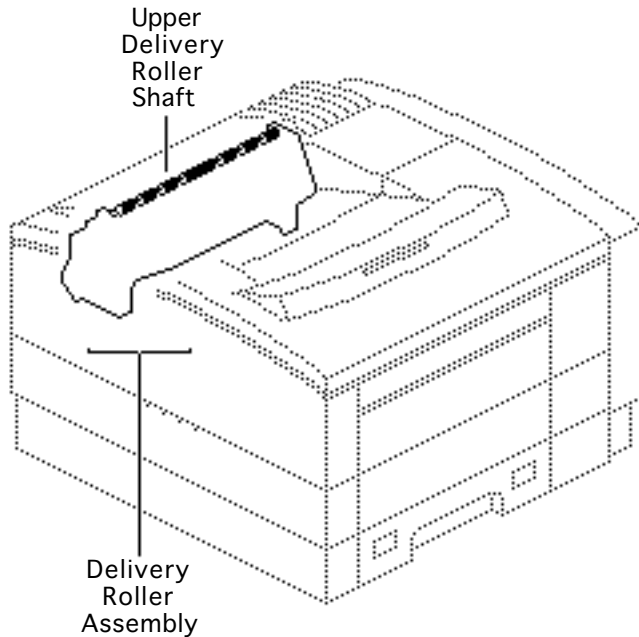

## Upper Delivery Roller Shaft

Before you begin, remove the following:

- Rear panel
- Top cover
- Delivery roller assembly
- Upper delivery guide





- 1 Remove the E-ring on the right side of the shaft and slide off the bushing.
- 2 Push the delivery roller shaft to clear the left grip and drive belt and lift the shaft from the delivery roller assembly.



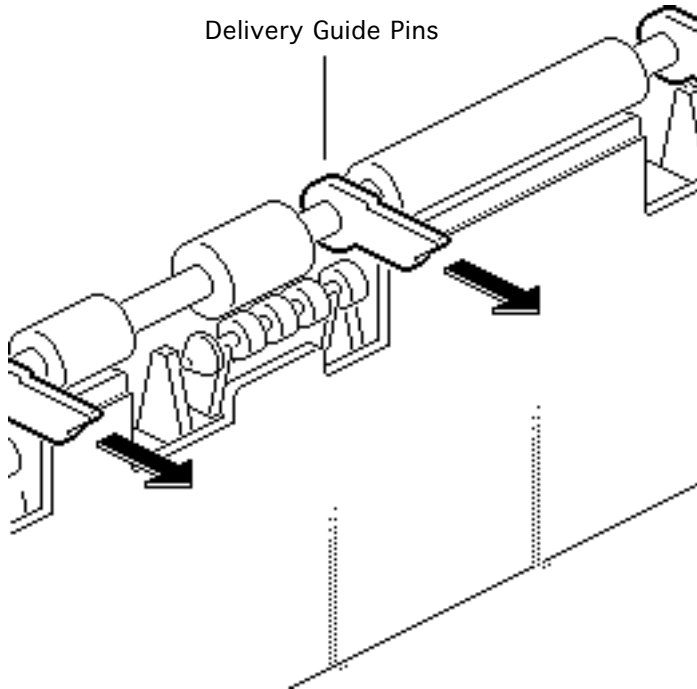

**Replacement Note:** The four small delivery guide pins that hang freely on the upper shaft must point outward (with the flow of paper).





## Delivery Drive Belt

Before you begin, remove the following:

- Rear panel
- Top cover
- Delivery roller assembly

**Note:** This cogged belt transfers drive upward to the delivery roller shafts. See “Mechanical Drive Theory” in Basics.

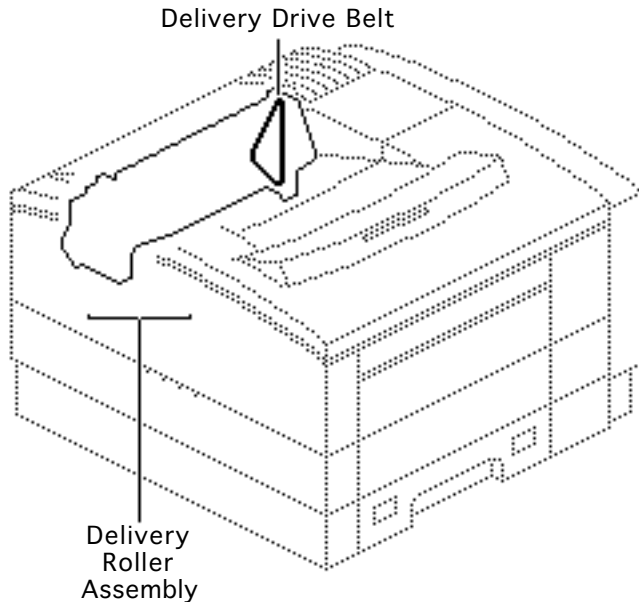

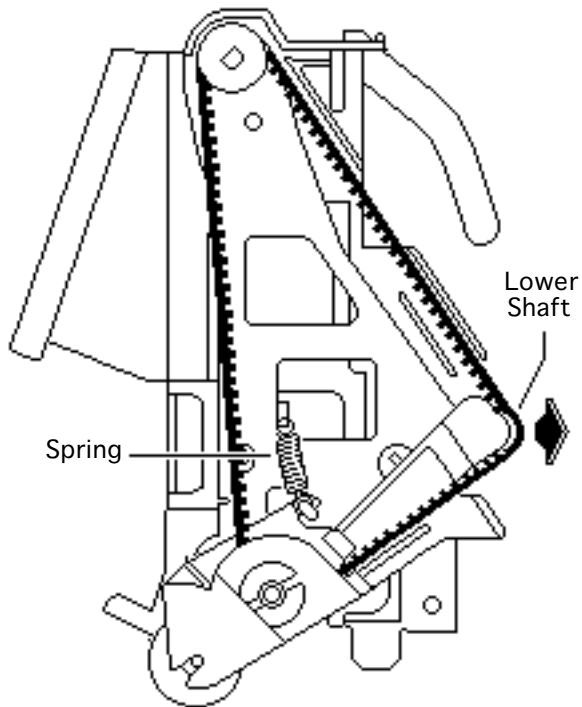

- 1 Remove the spring.
- 2 Slip the drive belt off the gear on the lower delivery roller shaft.



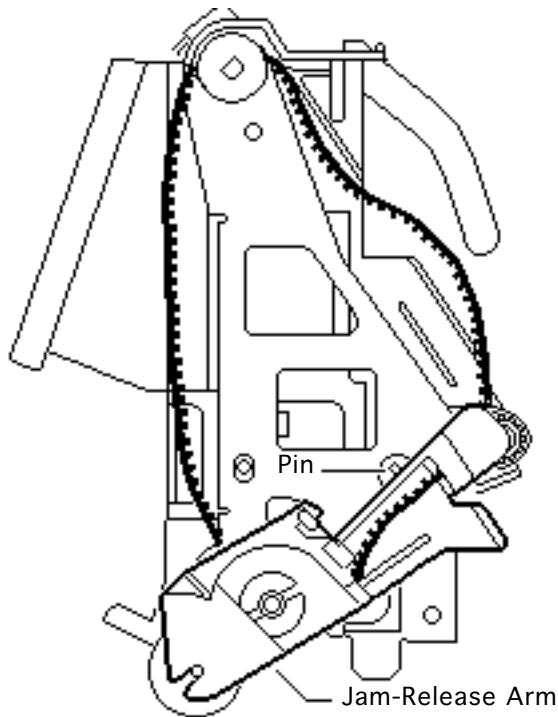

- 3 Rotate the green jam-release arm counter-clockwise as far as it will go, lifting the arm slightly to clear the small wedge-shaped pin.



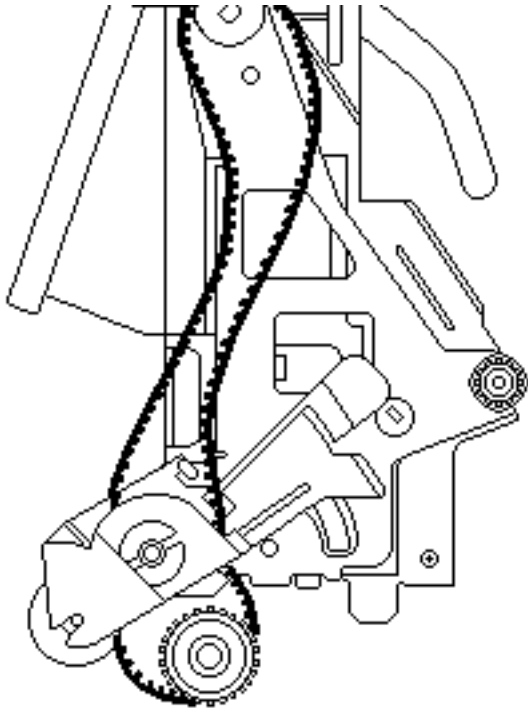

- 4 Pry off the jam-release arm with a small flat-blade screwdriver.

**Note:** The spindle is connected to the end plate so the gear is now free. It stays in place because the drive belt is holding it.

- 5 Push the belt through, slip off the gear, and pull out the drive belt.





**Replacement Note:** The final step in replacement is the looping of the belt over the lower roller shaft gear.

First, use the rounded end of the jam-release arm to stretch the belt outward. Then with your fingertips pressing the belt firmly against the side of the gear, slowly rotate the drive shaft and let the belt shift onto the gear.







## Delivery/Interlock Sensor

Delivery/Interlock Sensor

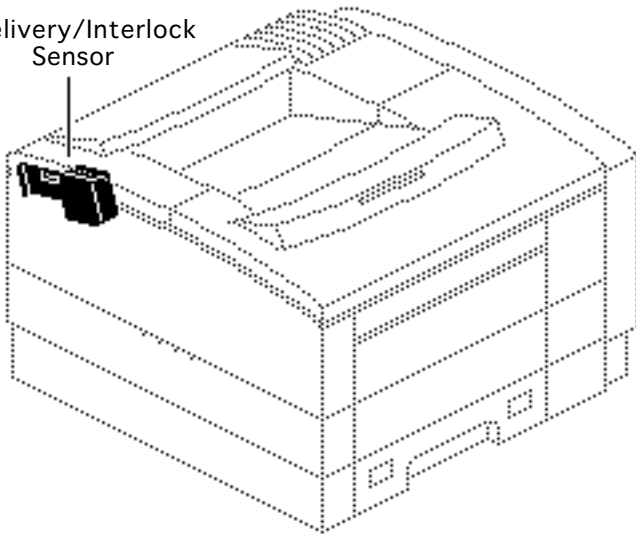

Before you begin, remove the following:

- Rear panel
- Top cover
- Delivery roller assembly

**Note:** The delivery/interlock sensor (PS201) senses closure of the fuser access door and the exiting of paper from the fuser assembly. See “Sensing System Theory” in Basics.



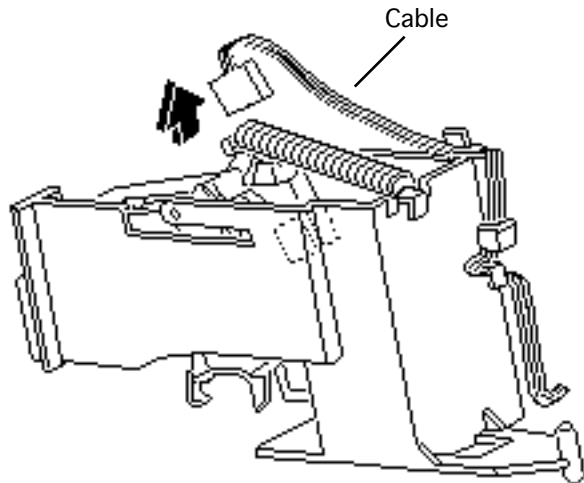

- 1 Disconnect the cable from the photo IC.





- 2 To remove the sensor holder from the printer, raise the upper edge and slide the holder upwards off the chassis.

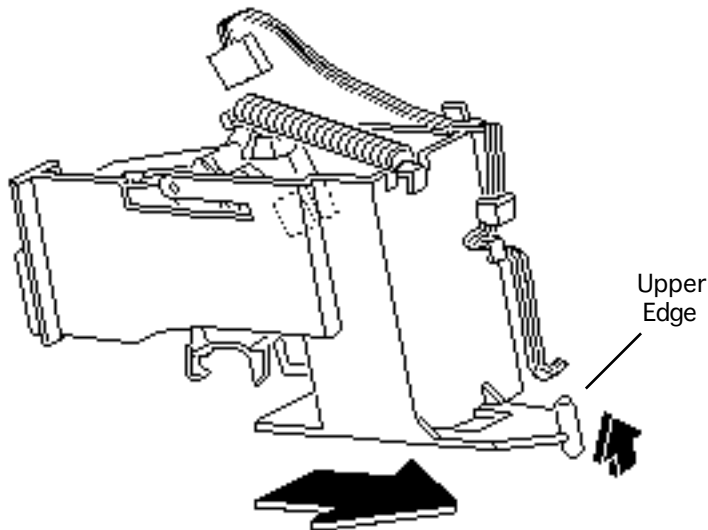

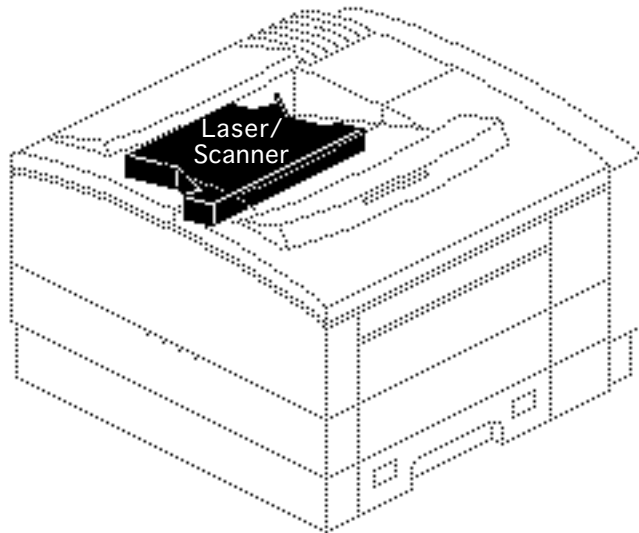

## Laser/Scanner Assembly

Before you begin, remove the following:

- Rear panel
- Top cover
- Delivery roller assembly

**⚠ Warning:** Review “LaserWriter Safety” in Basics before working with the laser/scanner assembly.

**Note:** The LaserWriter Pro laser/scanner assembly is available only as an integral assembly. No subparts are





available from Apple and no power adjustments are possible.

- 1 Remove the four cables from the cable clips and disconnect the cables at their connectors.

**Note:** There is no fiber-optic cable in the LaserWriter Pro. Beam detection circuitry runs through the BD IC unit at connector J731 (see “Wiring Diagram” in Troubleshooting Info).

- 2 Remove the four screws and lift the laser/scanner assembly from the printer.

**Note:** Remove the shutter and the shutter spring prior to returning a laser/scanner assembly to Apple.

**Replacement Note:** Perform the “Registration Adjustment” procedure (see Adjustments chapter).





Laser/Scanner  
Assembly

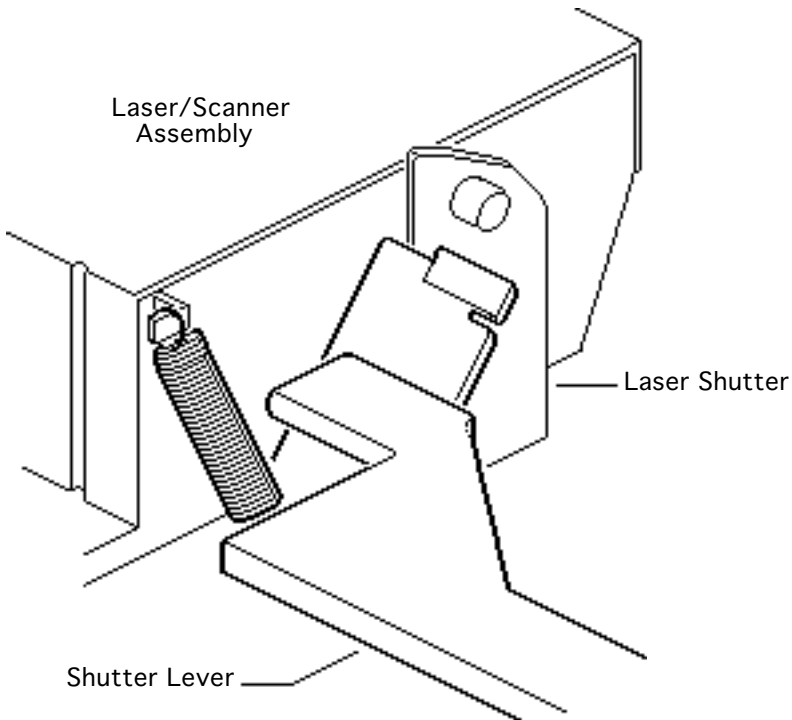

**Replacement Note:** Make sure that the shutter and the shutter lever are reinstalled in the position shown. Confirm installation by pushing the lever against the edge of the shutter. The shutter should open freely when actuated by the lever, and the shutter should spring back fully when you release it.



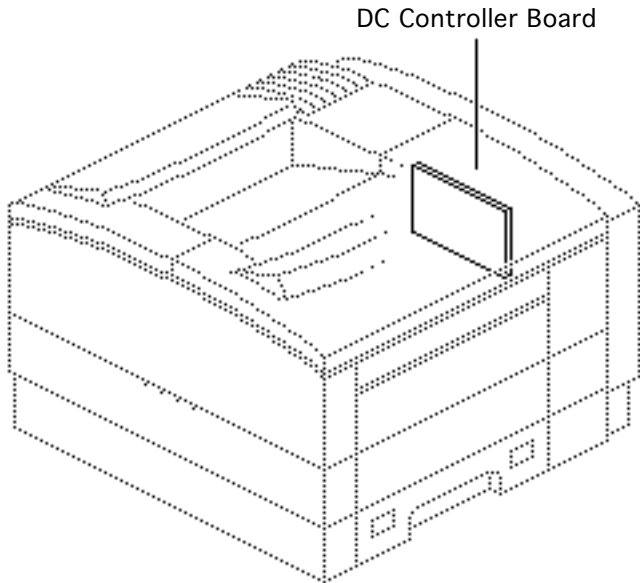

## DC Controller Board

Before you begin, remove the following:

- Rear panel
- I/O shield





- 1 Disconnect J103 from the power supply.
- 2 Remove the all cables except for the engine interface cable and power supply connector TB201.

**Note:** Do not attempt to remove connector TB201 from the DC controller board. Connector TB201 is hard-wired to the board.

- 3 Release the two flex tabs and pull the board out of the printer.

**Replacement Note:** Set the bottom edge of the board into the two mounts and then snap the top into place. Make sure that the positioning posts line up with the holes in the board.

**Note:** Perform the “Registration Adjustment” procedure (see Additional Procedures).





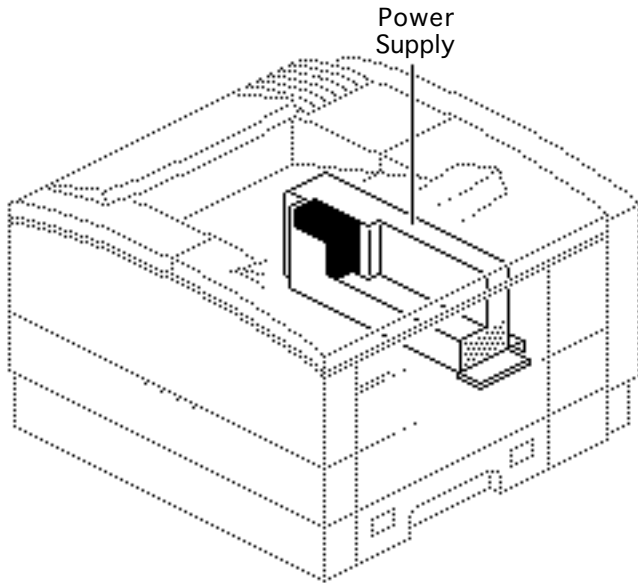

## Power Supply

Before you begin, remove the following:

- Rear panel
- I/O shield



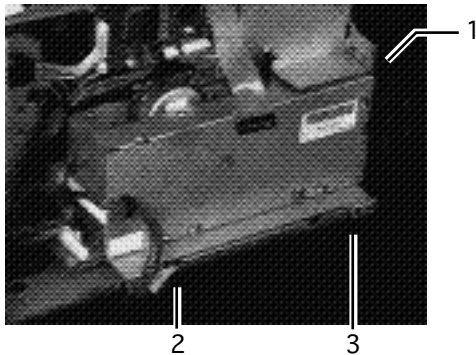
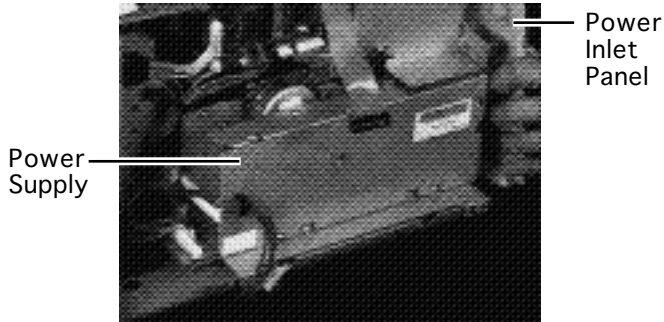

- 1 **Note:** Three screws secure the power supply to the chassis—one on the left side of the printer beneath the power inlet panel and two on the rear side.

Pull off the power inlet panel that covers the main power switch and remove the three screws.



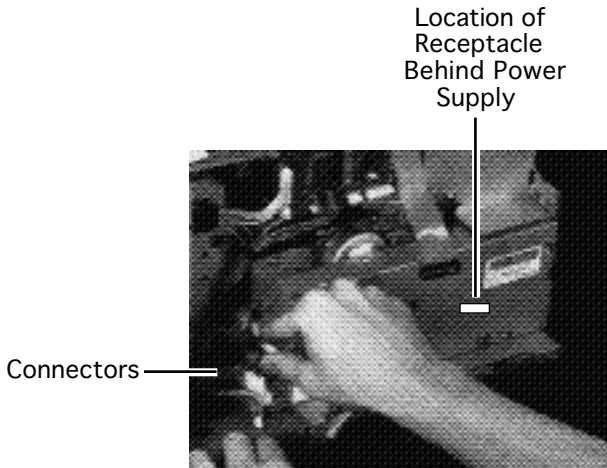

- Note:** There is a receptacle on the right rear face of the power supply. The receptacle mates with the high-voltage connector block and may cause slight resistance when you are pulling out the power supply.

Remove connectors J103 and J104 and pull out the power supply.



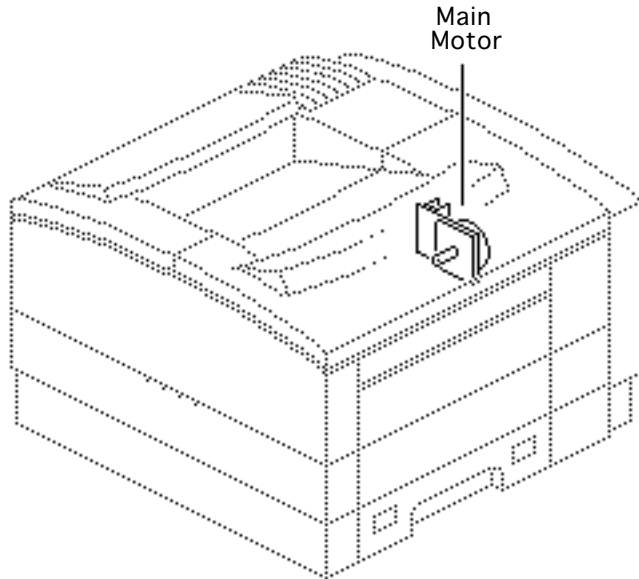

## Main Motor

Before you begin, remove the following:

- Rear panel
- I/O shield
- Power supply

**Note:** The main motor is the motor mounted next to the DC controller board. The main motor powers the drive train from the toner cartridge forward through the delivery rollers. See “Mechanical Drive Theory” in Basics.





- 1 Remove the four brass colored screws that secure the motor to the printer chassis.
- 2 Disconnect J131 from the main motor board and pull out the main motor.



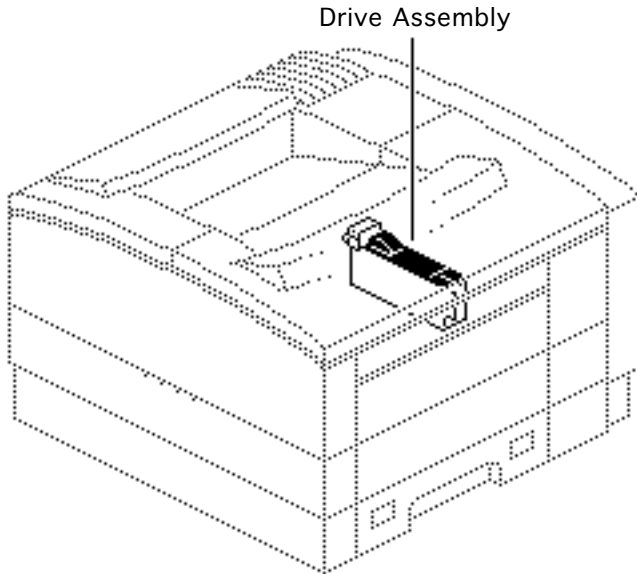

## Drive Assembly

Before you begin, remove the following:

- Fuser assembly
- Rear panel
- I/O shield
- Power supply
- Main motor

**Note:** The drive assembly receives drive from the main motor and transfers it forward to the fuser assembly gears. See “Mechanical Drive Theory” in Basics.

- 1 Remove the two small





silver-colored screws on the rear face of the chassis that secure the drive assembly to the printer.

- 2 **Note:** The following step dislodges the positioning pins that seat into the chassis wall.

Grip the edge of the assembly housing with needlenose pliers and pull it about 1/4 inch away from the chassis wall.

- 3 Pull the drive assembly out the fuser side of the printer.



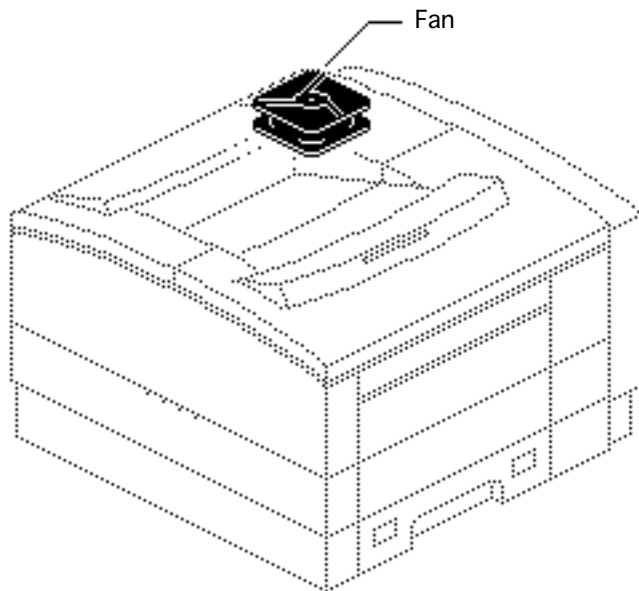

## Fan

Before you begin, remove the following:

- Rear panel
- Top cover
- I/O shield
- Delivery roller assembly

**Note:** The LaserWriter Pro engine has a single-fan exhaust system. This fan exhausts the I/O shield cavity directly and uses vertical ducting to exhaust the lower printer.







- 1 Disconnect J209 from the DC controller board.
- 2 Using a small flat-blade screwdriver, pry upward at the middle positioning pin and slide off the sheet metal fan bracket.
- 3 **Note:** A pair of flex tabs on each side of the fan duct hold the fan in place.

Using a small flat-blade screwdriver, release the three tabs and lift the fan out of the printer.





## High-Voltage Power Supply

No preliminary steps are required before you begin this procedure.

**Note:** The high-voltage power supply receives power from the high-voltage connector block and transfers it into the toner cartridge through contacts TB401 to TB406.

Remove the high-voltage power supply from its tray before returning the high-

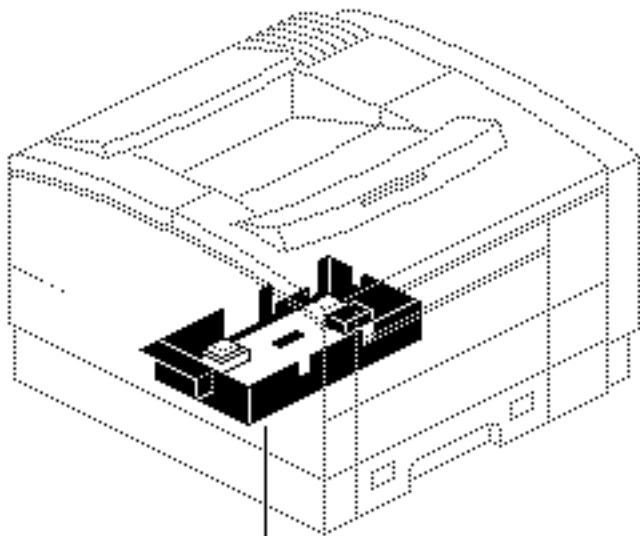

High-Voltage  
Power Supply





voltage power supply to Apple.

- 1 Turn over the printer.
- 2 Remove the two screws that secure the high-voltage power supply to the bottom chassis.
- 3 **Note:** There are three hidden contacts and a pin connector that mate with the high-voltage connector block. They may cause slight resistance when you are performing this procedure.

Release the two flex tabs and pull the high-voltage power supply out of the printer.

**Replacement Note:** Make sure that the contacts and connectors are firm. Run a service test page after replacing the high-voltage power supply. If you get a solid black page, you have probably not seated the high-voltage power supply correctly.





## High-Voltage Connector Block

Before you begin, remove the following:

- Rear panel
- I/O shield
- Power supply
- Fuser door
- Fuser assembly
- High-voltage power supply

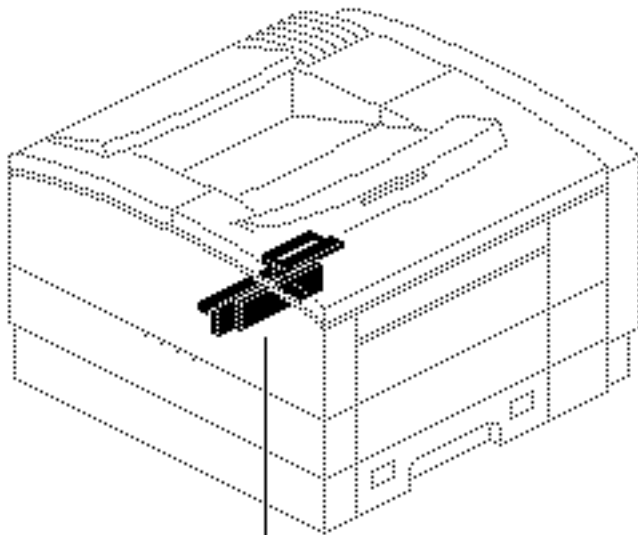

High-Voltage  
Pro





- 1 Remove the screw that secures the right cassette guide to the fuser end of the printer.
- 2 **Note:** The tab referenced in the following step is accessible from behind the rear wall of the chassis.  
Release the single flex tab with your finger and shimmy the cassette guide off the printer.
- 3 Disconnect J210 (the orange cabling) from the DC controller board.
- 4 Release the expansion posts behind the receptacle that is anchored into the chassis wall, detach the receptacle, and push the receptacle back through the chassis opening.
- 5 Release the flex tab near the cable tie and receptacle and remove the connector block from the printer.



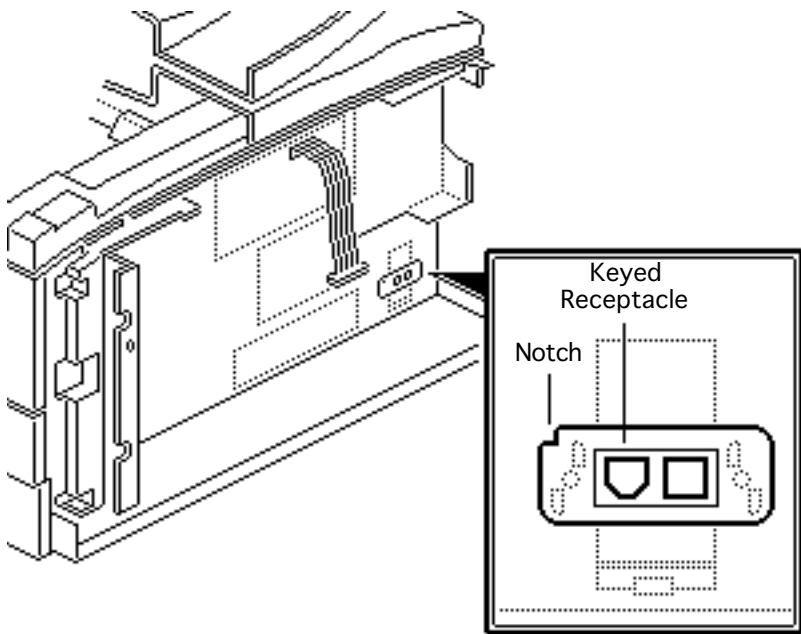

**Replacement Note:** The cable receptacle is keyed and will not mate with the power supply if it is installed incorrectly. Looking from the rear of printer, with the printer sitting upright, the notched corner should be at the upper left.





## Paper Pickup Block

Before you begin, remove the following:

- Rear panel
- Top cover
- Front panel
- Right corner panel
- Multipurpose tray assy
- Multipurpose closure panel

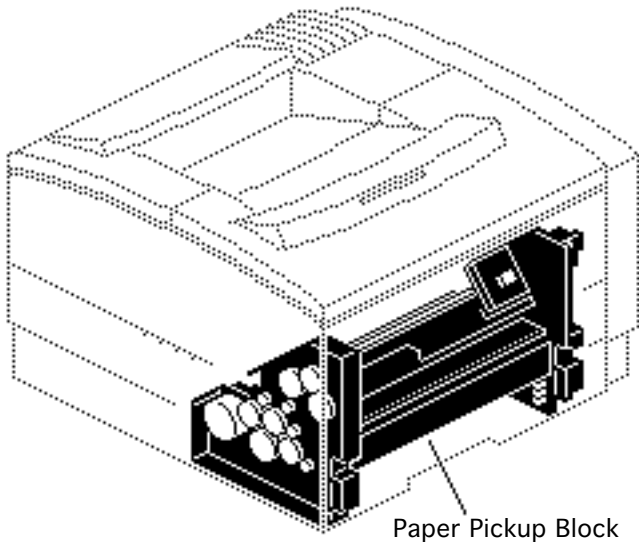



**Note:** Refer to the following take-apart topics for disassembly of the paper pickup block:

- Pickup Controller Board
- Pickup Sensor Board
- Pickup Block Motor
- Envelope Feeder Cable
- Sensor Holder Assembly
- Left Pickup Block Frame

**Note:** The paper pickup block is not available from Apple as an intact module.

- 1 Remove the three brass-colored screws on the front chassis.
- 2 Remove the two screws that secure the lateral brace to the chassis and lift off the brace.







- 3 Remove the two screws that secure the right edge of the pickup block to the chassis.
- 4 Disconnect the two cables from the exposed edge of the pickup controller board.
- 5 Grasp the pickup block and slide it out of the printer.

**Replacement Note:** Perform the “Registration Adjustment” procedure (see Adjustments chapter).





## Pickup Controller Board

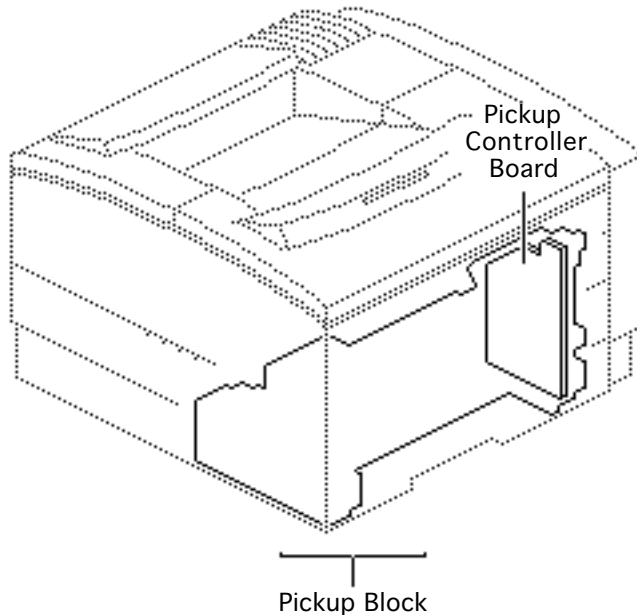

Before you begin, remove the following:

- Rear panel
- Top cover
- Front panel
- Right corner panel
- Multipurpose tray assy
- Multipurpose closure panel
- Paper pickup block

**Note:** Control of the following parts either routes through or is located on the pickup controller





board:

- Pickup sensor board
  - Pickup motor and drive gears
  - Top cover interlock switch
  - Service test page button
  - Cassette and envelope feeders
  - Cassette microswitches
  - Cassette paper sensor
- 1 Disconnect the two cables and remove the two screws that secure the board to the pickup block.
  - 2 **Caution:** The top cover interlock actuator is not attached to anything. Once you remove the board, the actuator can fall out and is difficult to find.

Release the tabs from top to bottom and pull out the board. There is a pin connector on the hidden face of the board that may cause slight resistance as you remove the board.





## Pickup Sensor Board

Before you begin, remove the following:

- Rear panel
- Top cover
- Front panel
- Right corner panel
- Multipurpose tray assy
- Multipurpose closure panel
- Paper pickup block
- Pickup controller board

**Note:** Control of the following parts either routes through or is located

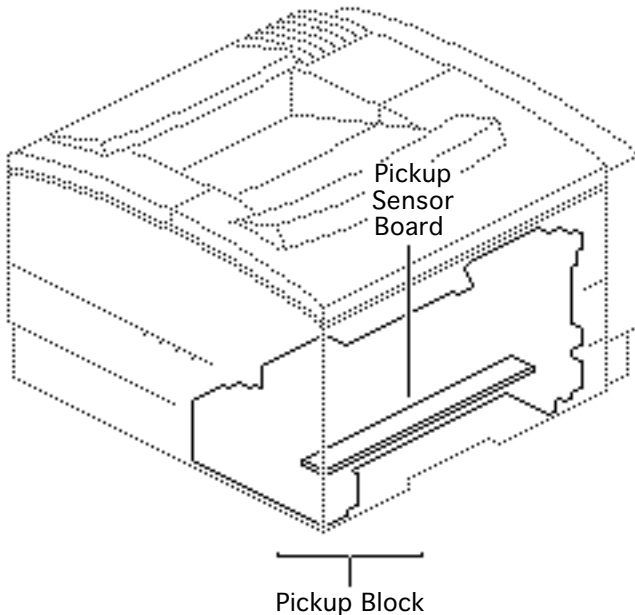

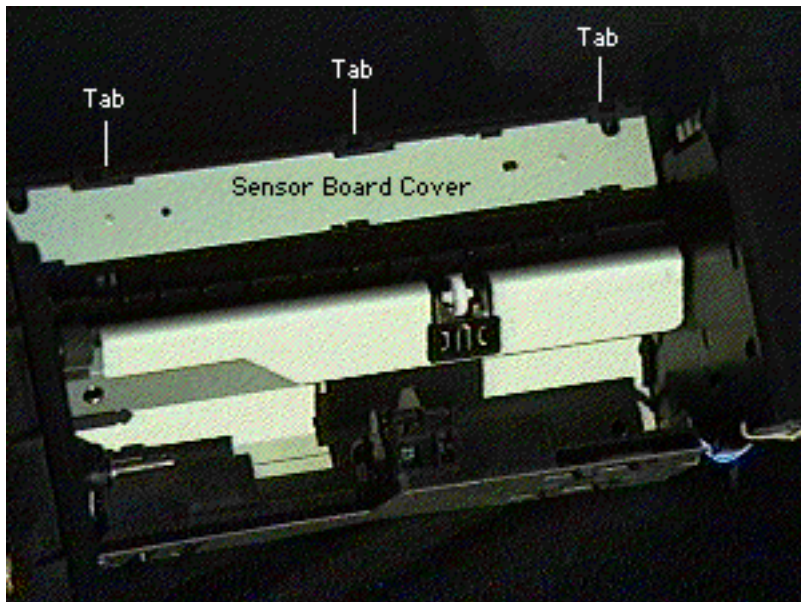

on the pickup sensor board:

- Multipurpose feed sensor
- Cassette feed sensor
- Pickup motor and drive gears
- Pickup solenoids

- 1 Turn over the pickup block so that it is resting on the 45° face of its end frames.
- 2 Unhook the three tabs and snap off the sensor board cover.
- 3 Disconnect the three cables at the gear end of the board.





- 4 **Note:** In the following instruction, “left” is the gear end and “right” is the controller board end of the pickup block.

Raise the board slightly to clear the two positioning pins, shift it about 1/2 inch to the left, rotate the right end upward, and remove the sensor board from the paper pickup block.





## Pickup Block Motor

Before you begin, remove the following:

- Rear panel
- Top cover
- Front panel
- Right corner panel
- Multipurpose tray assy
- Multipurpose closure panel
- Paper pickup block

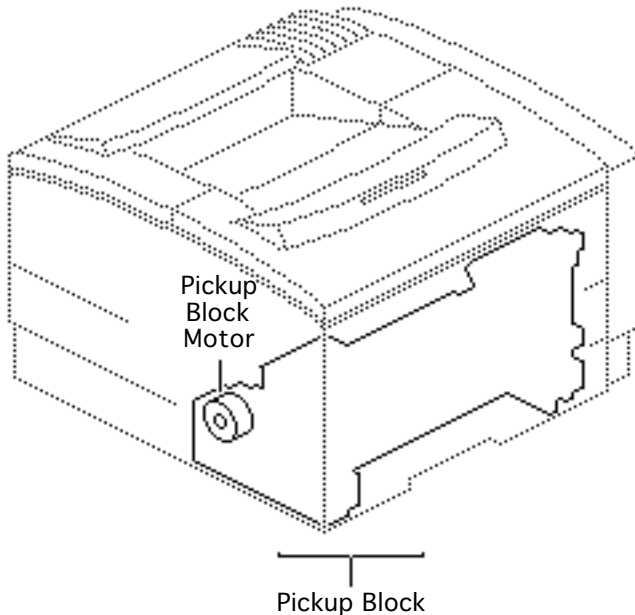

**Note:** The pickup block motor is the motor mounted in the left pickup block frame. The pickup block





motor powers the drive train from paper pickup forward to the toner cartridge. See “Mechanical Drive Theory” in Basics.

- 1 Disconnect the middle cable from the pickup sensor board.
- 2 Remove the pickup block motor cabling from the entire length of its retaining channel.
- 3 Remove the two long brass-colored screws that secure the motor to the pickup block and lift out the motor.







## Cassette Pickup Roller

No preliminary steps are required before you begin this procedure.

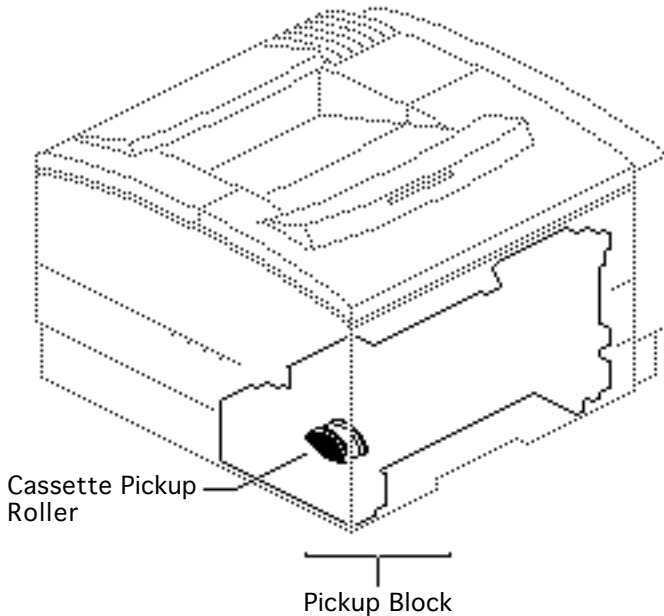

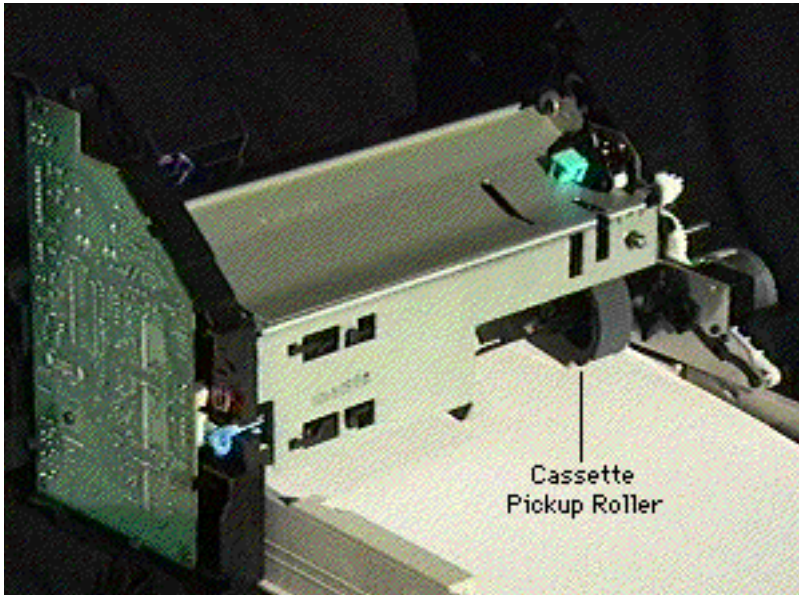

- 1 Turn over the printer and locate the cassette tray pickup roller.
- 2 Squeeze the spring release at the end of the roller shaft and slide off the pickup roller.

**Replacement Note:** Make sure that the roller slides all the way in on the shaft and locks into place.





## Multipurpose Pickup Roller

Before you begin, remove multipurpose closure panel.

- 1 Squeeze the spring release at the end of the roller shaft and slide off the pickup roller.

**Replacement Note:** Make sure that the roller slides all the way in on the shaft and locks into place.

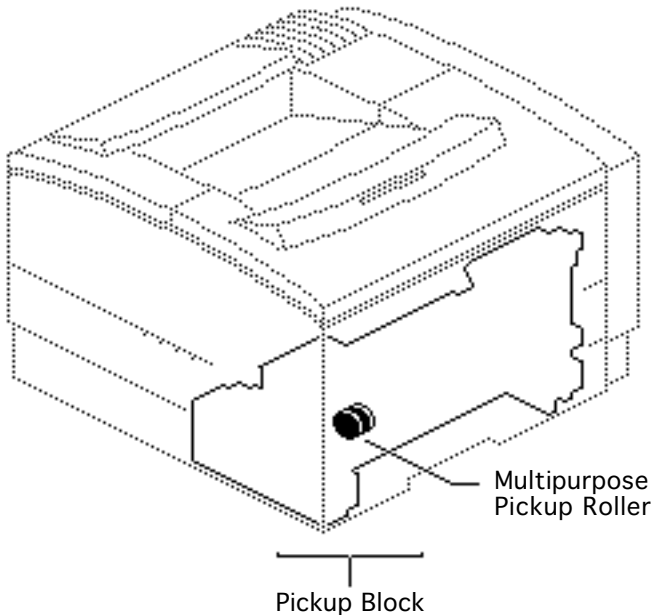



## Separation Pad

Before you begin, remove the following:

- Multipurpose closure panel
- Multipurpose pickup roller

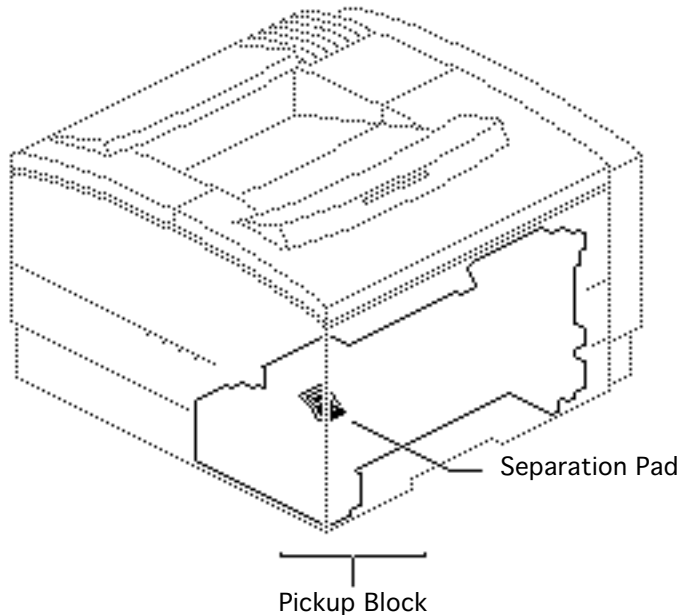

**Note:** The separation pad is available as a part of the multipurpose tray guide assembly (P/N 922-0286). Remove the separation pad from the new tray guide assembly and install it in the printer.





- 1 Using a small flat-blade screwdriver, pry underneath the bottom edge of the separation pad and remove the pad.





## Envelope Feeder Cable

Before you begin, remove the following:

- Rear panel
- Top cover
- Front panel
- Right corner panel
- Multipurpose tray assy
- Multipurpose closure panel
- Paper pickup block
- Pickup controller board

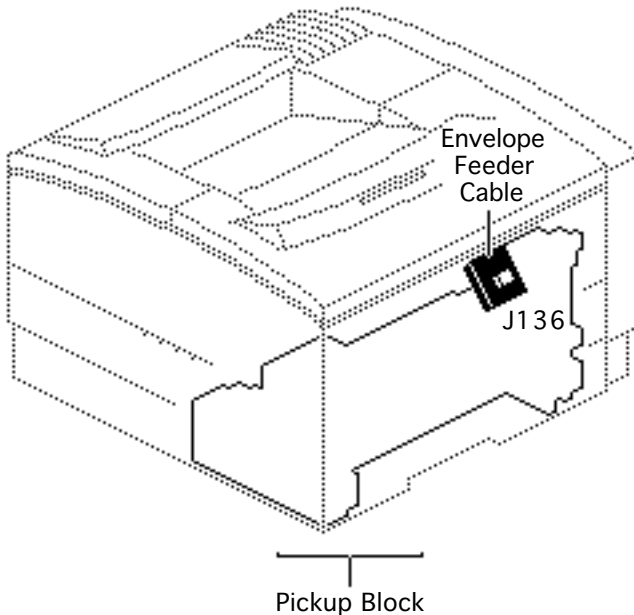



- 1 Remove the cabling from the entire length of its retaining channel in the right pickup block.

**Note:** If you are replacing the feeder cable without replacing the feeder cable mount, skip to step 7.

- 2 **Note:** The opening guide is the rounded metallic plate with the green knob at its far end. The opening guide hinges around a ring connection at the knob end and an open grip connection at the near end.

Swing the opening guide upward about 90°, free the grip connection, and pull the guide up and out of the pickup block.

- 3 Disconnect the grounding spring from the pickup block.



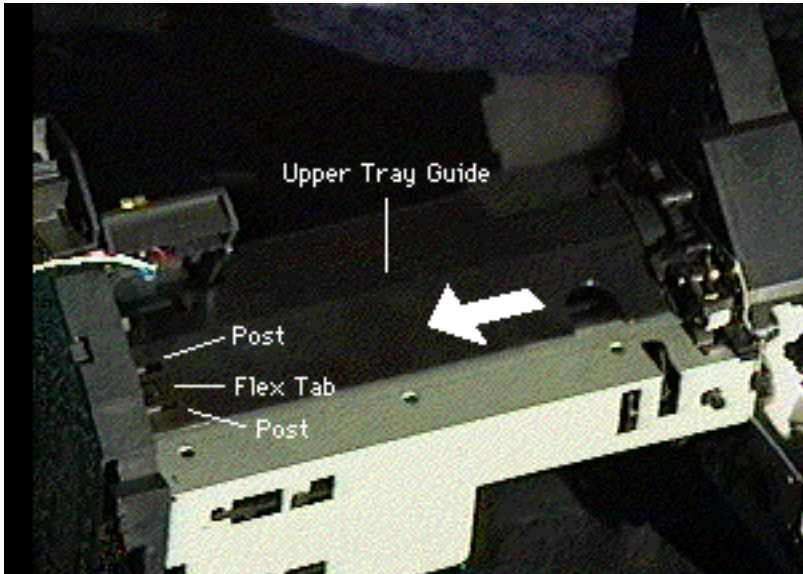

- 4 **Note:** The upper tray guide is the black piece below the opening guide. It has a rounded cutout on its far side that serves as a grip point for the step below. A flex tab and two posts are located at the controller end of the upper tray guide.

Release the flex tab, shift the upper tray guide to clear the posts, and lift the guide out of the pickup block.





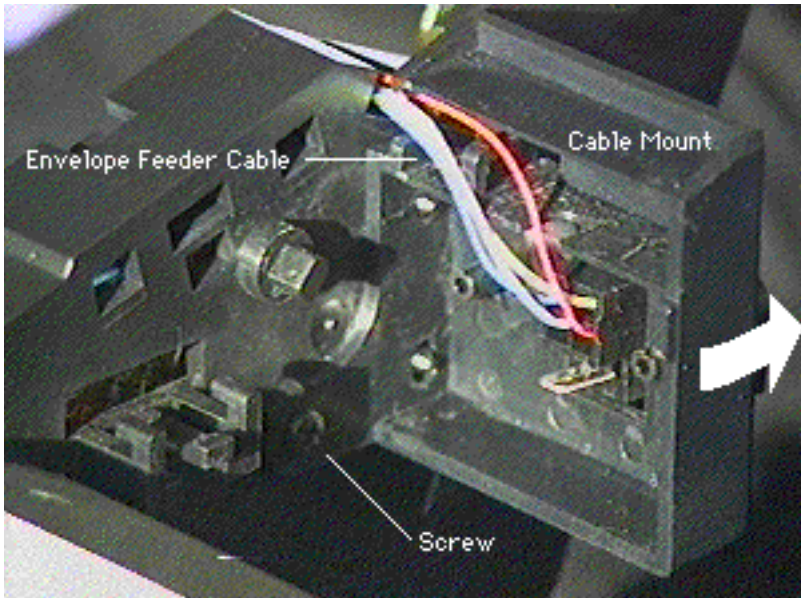

- 5 Remove the screw that secures the cable mount to the pickup block frame.
- 6 Rotate the cable mount outward to free the two mounting tabs and remove it from the pickup block.
- 7 Release the expansion posts behind the receptacle and remove the envelope feeder cable from the cable mount.





## Sensor Holder Assembly

Before you begin, remove the following:

- Rear panel
- Top cover
- Front panel
- Right corner panel
- Multipurpose tray assy
- Multipurpose closure panel
- Paper pickup block
- Cassette pickup roller

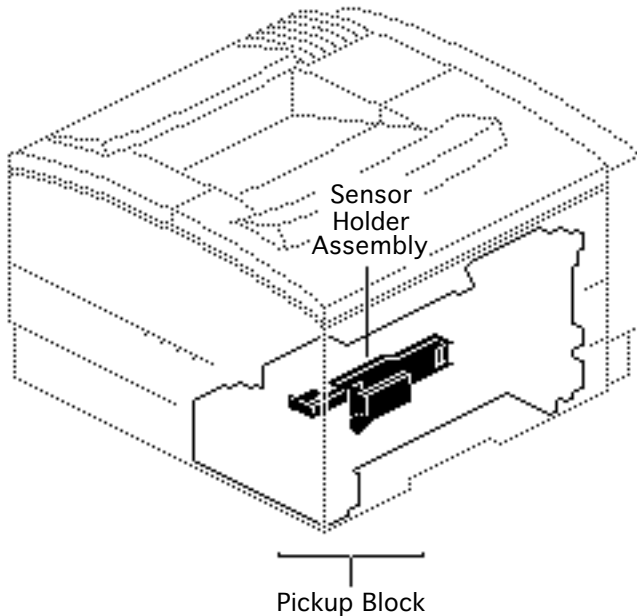

**Note:** The sensor holder assembly contains the cabling, actuators, and photo





interrupters for cassette paper sensor PS601 and registration paper sensor PS602.

- 1 Rest the entrance side of the pickup block flat on your work surface.
- 2 Disconnect J605 from the pickup controller board.



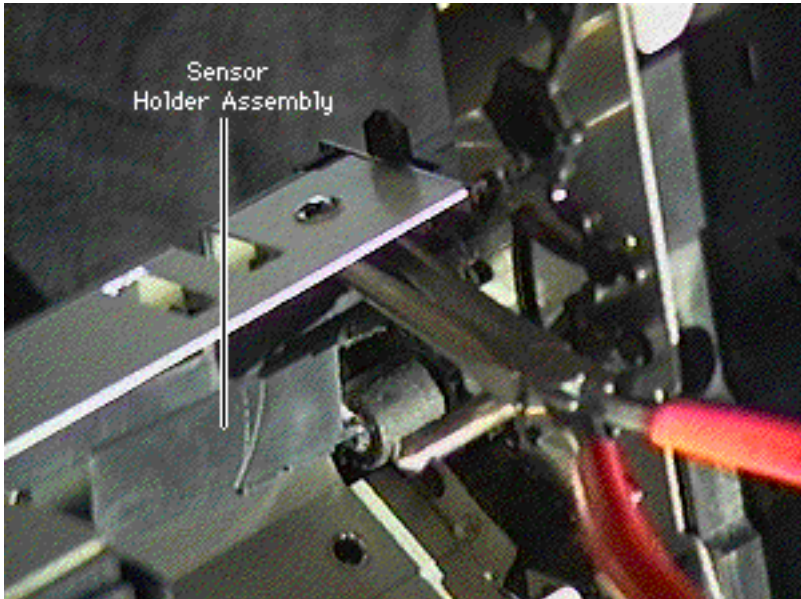

- 3 **Note:** The sensor holder assembly is held in place by a positioning post at the far end and two pairs of tab connectors at the near end.

Press the positioning post through the metal flange and grasp the throat of the pin with needlenose pliers.





- 4 **Note:** Pull the sensor holder assembly toward the gear end of the pickup block while you perform the following step.

Release the two tabs, unmount the holder assembly, and shimmy it out of the pickup block.





## Left Pickup Block Frame

Before you begin, remove the following:

- Rear panel
- Top cover
- Front panel
- Right corner panel
- Multipurpose tray assy
- Multipurpose closure panel
- Paper pickup block

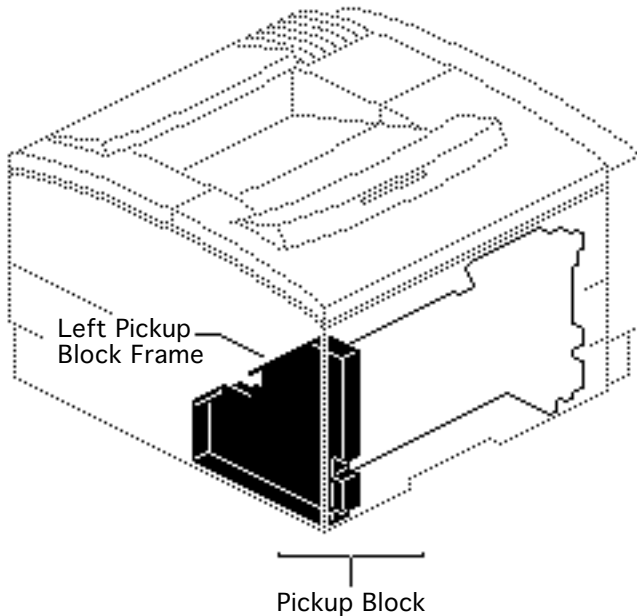

**Note:** Removal of the left frame is necessary only if you need to get to some of the components on the inside





face of the frame, such as the feed rollers, gear mount, or the sensor arm. You must also remove the left frame to get the paper guide plate and its spring out of the pickup block. The Take Apart procedures do not address disassembly beyond this topic.

- 1 Set the pickup block on end with the left frame up.
- 2 Remove the two black and two silver-colored screws that connect the frame to middle components.
- 3 Lift the left frame straight up and off the pickup block.

**Note:** The inside of the frame is now accessible for further troubleshooting or take apart



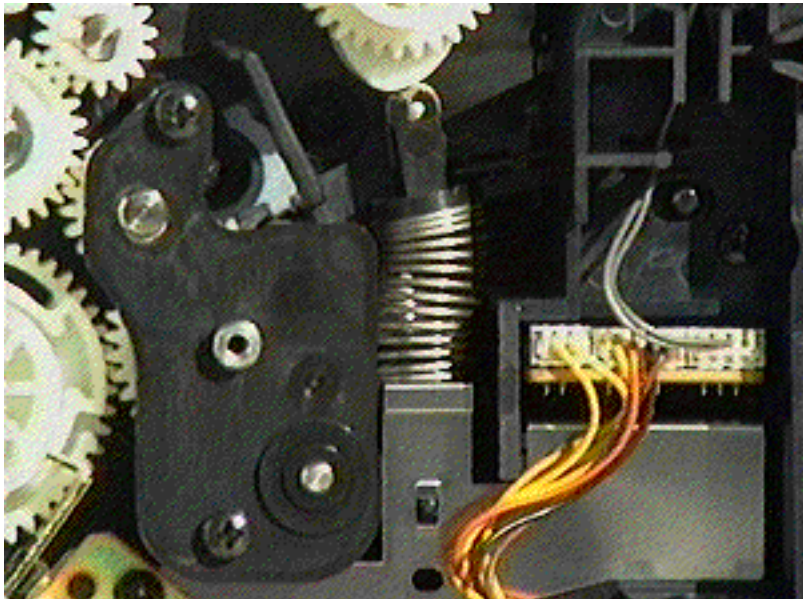

**Replacement Note:** The key step in reassembly is correctly installing the paper guide plate and its spring. The guide plate presses against the gear that drives the multipurpose pickup roller. If the plate does not press against this gear, the pickup roller will either slip or remain in neutral and no paper will be pulled into the printer from the multipurpose tray. Your drum shaft end plate may differ from what is shown.







Reinstall the lower guide (the flexible guide with ribs) after the pickup block is intact. Temporarily loosen the four screws on the right block frame and release the frame about 1/8 inch to allow for the reseating of the lower guide.





## Transfer Roller

No preliminary steps are required before you begin this procedure.

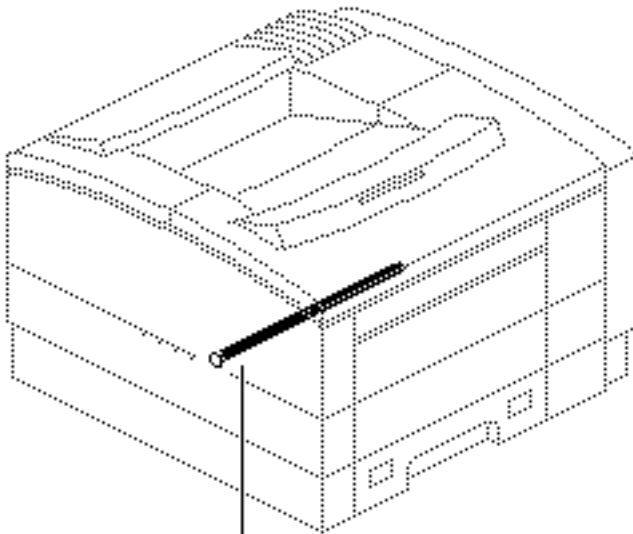

Transfer Roller





- 1 Hook the left end of the roller with the green cleaning brush and pull the roller out of the printer.

**Replacement Note:** Slide the right end of the roller into the slot and lower the gear end into place.

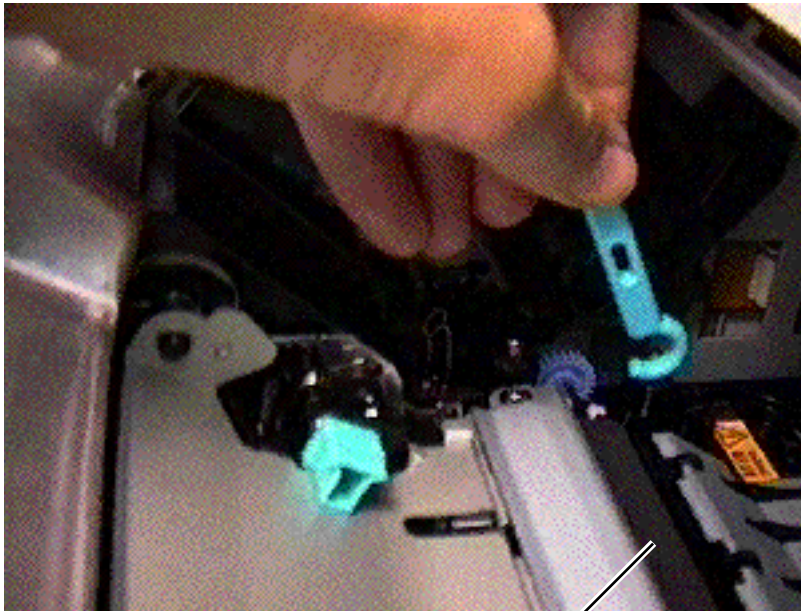

Transfer Roller





## Transfer Guide Assembly

Before you begin, remove the following:

- Rear panel
- Top cover
- Front panel
- Right corner panel
- Multipurpose tray assy
- Multipurpose closure panel
- Paper pickup block

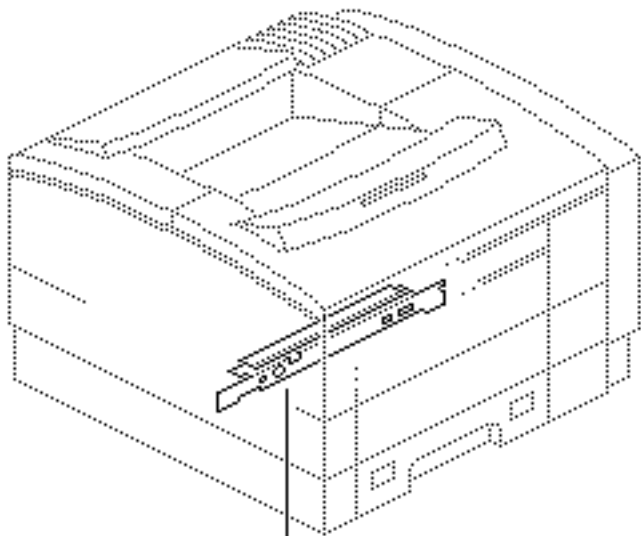

Transfer Guide Assembly





- 1 Remove the two black screws that secure the transfer guide assembly to the toner cartridge guides and pull the transfer guide assembly out the right side of the printer.





## Transfer Block Assembly

Before you begin, remove the following:

- Rear panel
- Top cover
- Front panel
- Right corner panel
- Multipurpose tray assy
- Multipurpose closure panel
- Paper pickup block
- Transfer guide assembly
- Fuser assembly

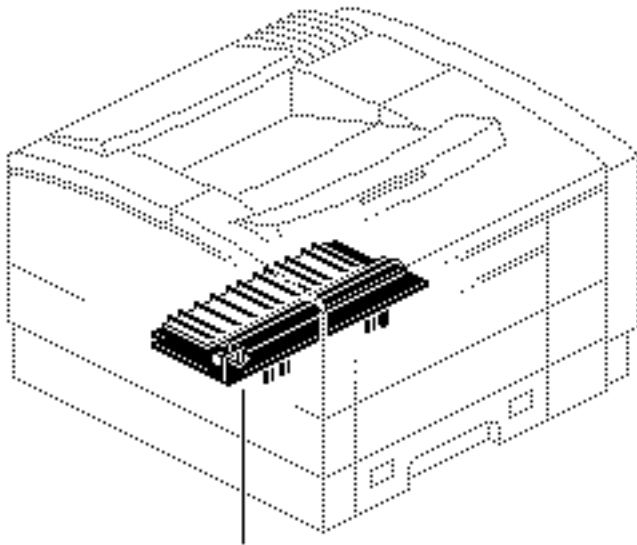

Transfer Block Assembly





- 1 For clearance purposes, loosen the nine silver-colored screws and the one upper black screw about 1/8 inch and shift the front wall outward.
- 2 Remove the screw facing out through the fuser door that secures the feeder guide to the chassis.
- 3 Pry under the toner-side edge of the assembly with a small flat-blade screwdriver and release the five tabs that secure the transfer block assembly to the chassis.
- 4 **Note:** The underside of the transfer block assembly has several contact pins that extend down into the high-voltage power supply and tend to snag during removal. Be careful not to damage them as you perform the following step.

Lift the assembly straight upward about 2 inches and shimmy it out the toner side of the printer.





## Envelope Feeder

Before you begin, remove the multipurpose closure panel.

**Note:** Refer to the Envelope Feeder manual for further information.

- 1 To install the envelope feeder, turn off the printer, slide the feeder into the paper pickup block, and turn on the printer.

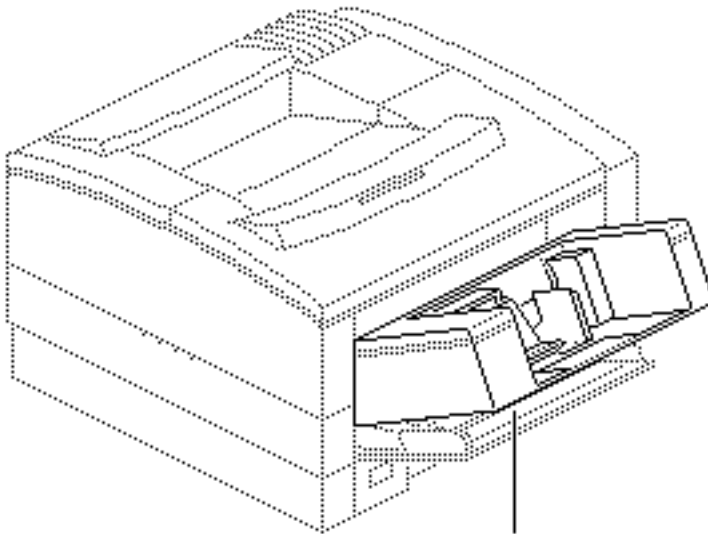

Envelope Feeder







## Sheet Feeder

No preliminary steps are required before you begin this procedure.

**Note:** Refer to the Sheet Feeder manual for further information.

- 1 To install the sheet feeder, turn off the printer, place the printer in position over the feeder and lower the printer into position. Then turn on the printer.

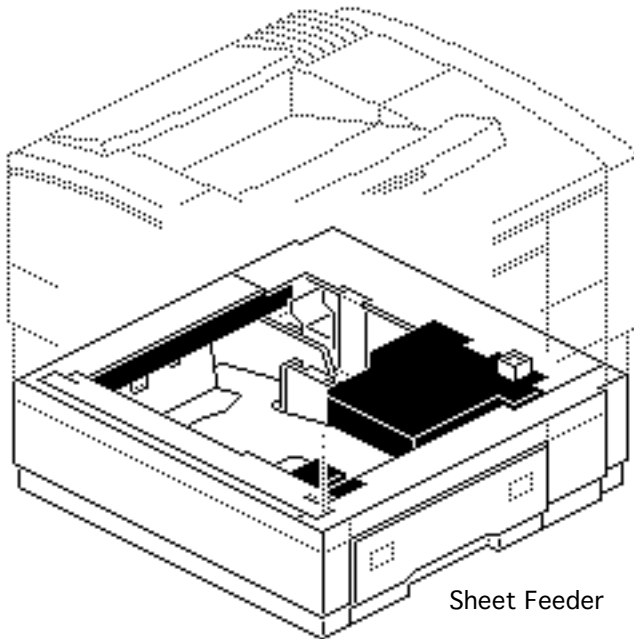

Sheet Feeder





## Upgrades

---

LaserWriter Pro 600/630





## Upgrading RAM

Before you begin, remove the following:

- Rear panel
- I/O shield

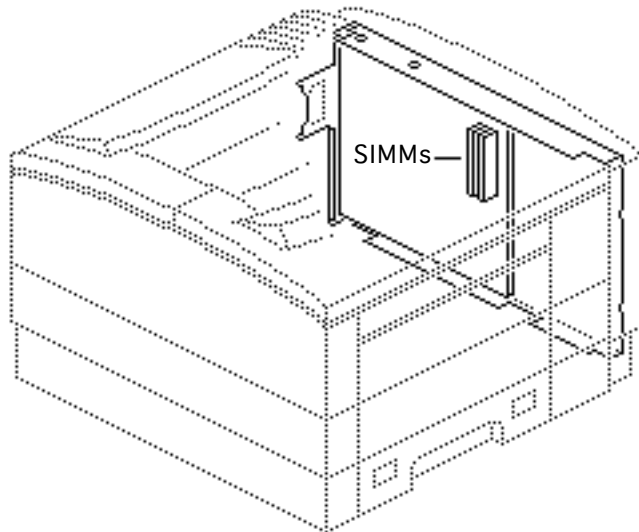

**Note:** If you are upgrading the RAM in a LaserWriter Pro 600 from 4 MB to 8 MB or more, perform the "PhotoGrade Medallion" procedure. The LaserWriter Pro 600 requires 8 MB of memory to print at 600 dpi or to print PhotoGrade images.



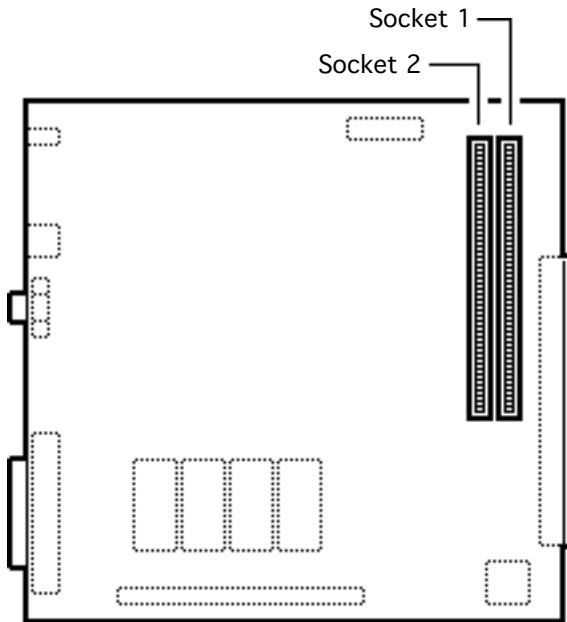

Refer to the Memory manual for configuration and parts information. SIMM configurations are governed by the following:

- 1 Socket 1 can hold a SIMM with one or two DRAM banks.
- 2 Socket 2 can hold a SIMM with one RAM bank. Socket 2 must never contain a two-bank SIMM. Socket 2 may be loaded with a single-bank SIMM only if socket 1 contains a single-bank SIMM.





## Upgrading I/O Board

Before you begin, remove the following:

- Rear panel
- I/O shield

**Note:** The Laser Writer Pro Upgrade Kit consists of a LaserWriter Pro 630 I/O board with a single 8 MB RAM SIMM. The board comes fully configured in a labelled I/O shield.

Return the old I/O board to Apple with the I/O shield

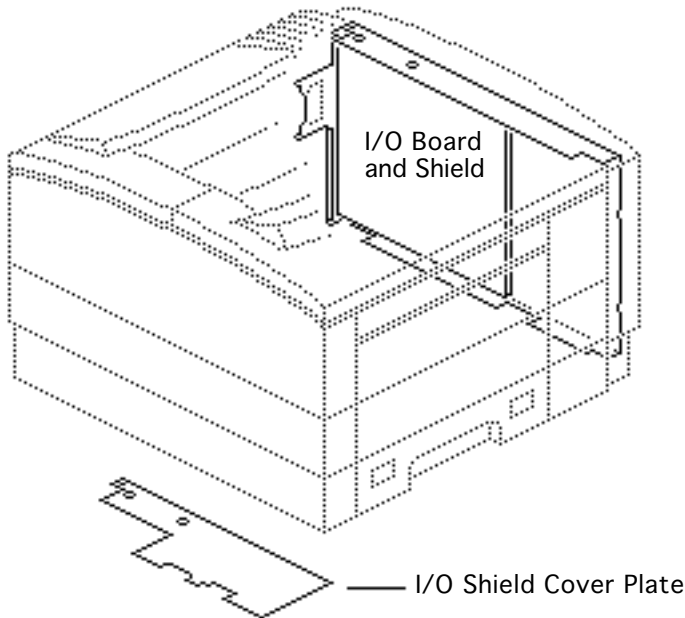



attached and with 4 MB of RAM. Save the I/O shield cover plate to use with the new board and shield. If the customer has previously upgraded memory beyond 4 MB, remove the additional RAM and return it to the customer.

Perform the "PhotoGrade Medallion" procedure after completing this upgrade.



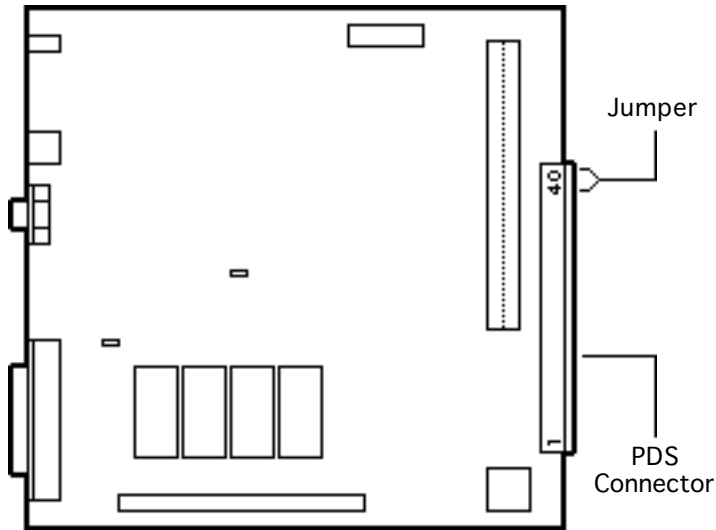

You can add third-party expansion boards to the LaserWriter Pro I/O board by connecting them to the Processor Direct Slot (PDS) connector. Follow installation instructions that come with the product.

**Caution:** If a small orange jumper is present on the PDS connector, make sure to remove the jumper prior to installing an expansion board.





## PhotoGrade Medallion

Affix the medallion to the front panel of the printer after you have performed one of the following tasks:

- Upgrading the RAM to 8 MB or more on a LaserWriter Pro 600 I/O board (see "Upgrading RAM")
- Upgrading the printer from a LaserWriter Pro 600 to a LaserWriter Pro 630 (see "Upgrading I/O Board")

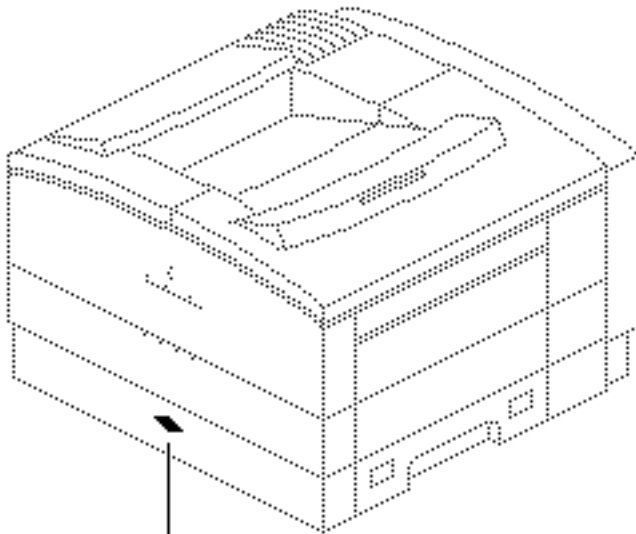

PhotoGrade Medallion







There is a tiny pinhole in the front panel that you use as a guide to position the PhotoGrade medallion. The pinhole is aligned with the Apple logo and is located on the edge of the lower ridge of the front panel.

- 1 Locate the pinhole on the front panel.

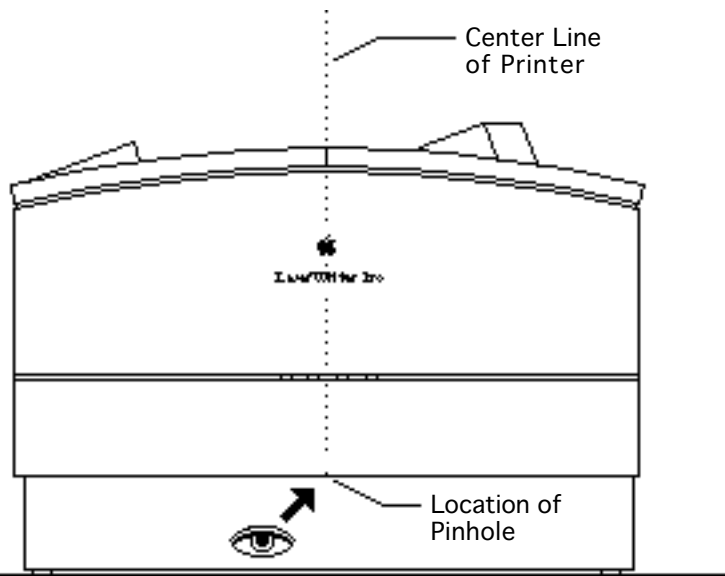

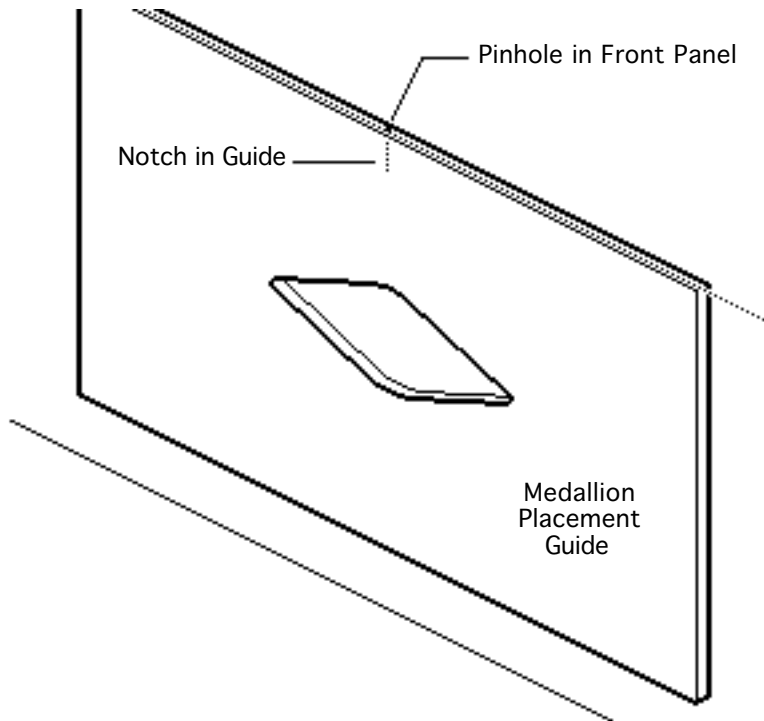

- 2 Position the placement guide on the front panel with the top edge of the guide flush with the ridge on the front panel.
- 3 Align the notch in the guide with the pinhole in the front panel.



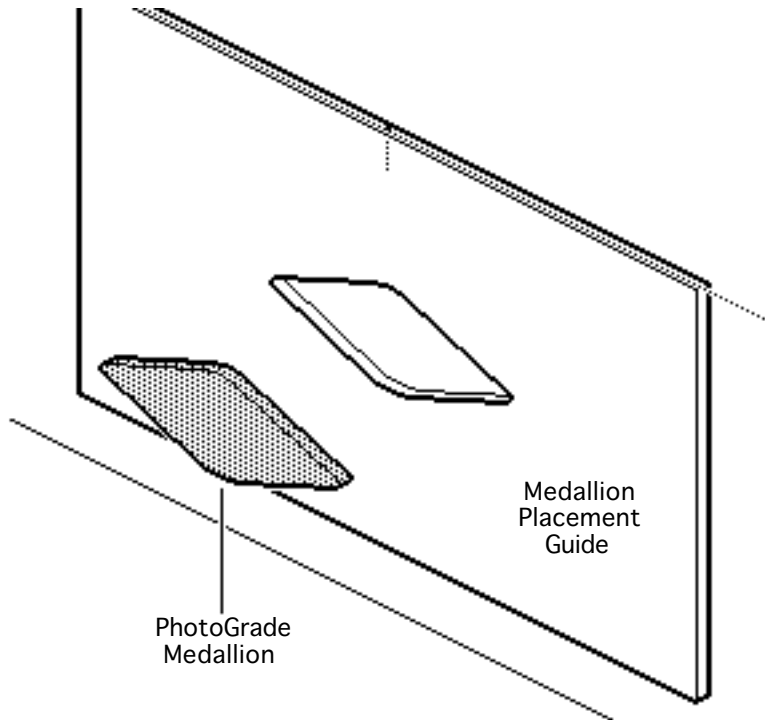

- 4 Remove the liner from the back of the medallion and position the medallion in front of the placement guide.



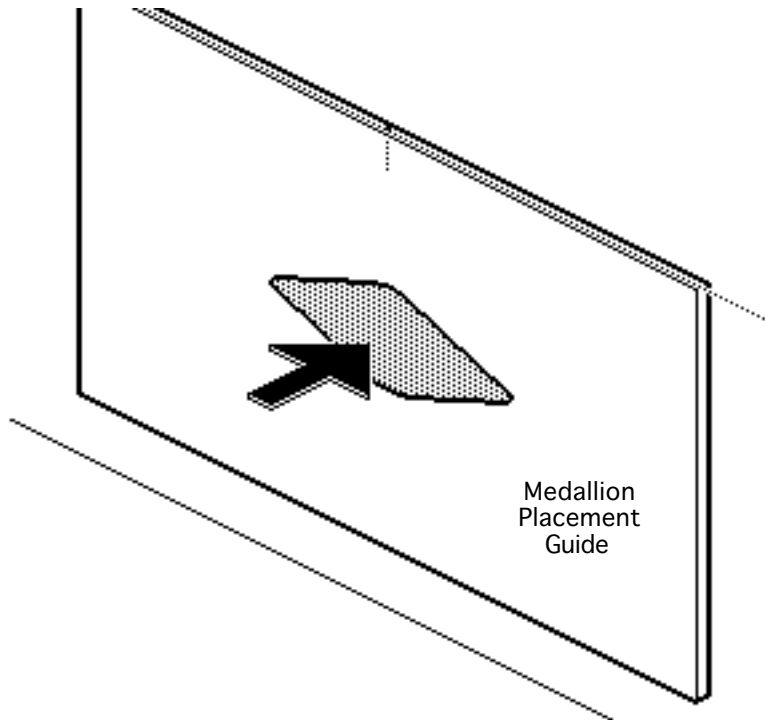

- 5 Affix the medallion to the panel through the opening in the placement guide.





PhotoGrade  
Medallion

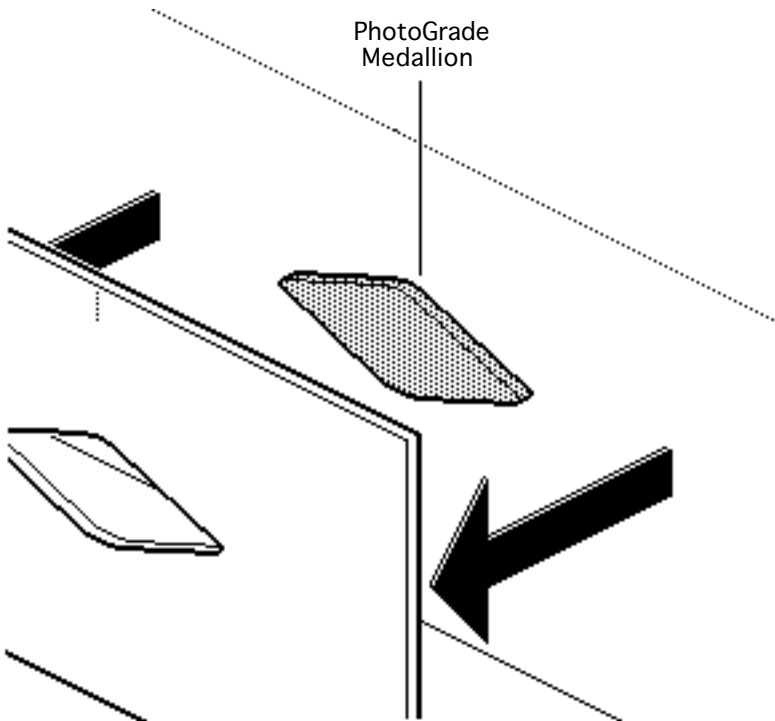

- 6 Remove the placement guide.





## Adjustments

---

LaserWriter Pro 600/630



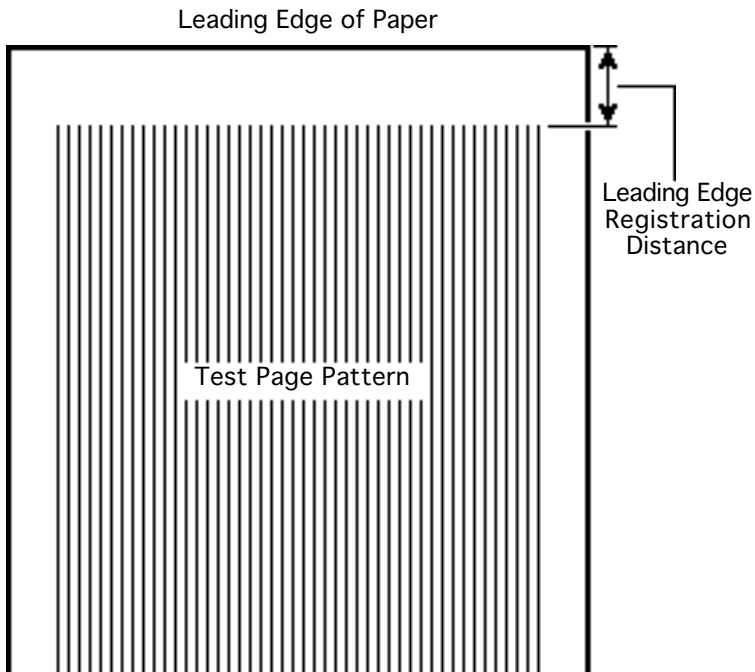

## Registration Adjustment

Before you begin, remove the following:

- Rear panel
- Top cover

You must perform the registration adjustment procedure whenever you replace the DC controller board, paper pickup block, or the laser/scanner assembly.

The DC controller board calculates registration based





on input from registration paper sensor PS602 (see “Sensing System Theory” in Basics) and adjustments made to varistor VR202 on the DC controller board.

Optimum leading edge registration distance is 2 mm.





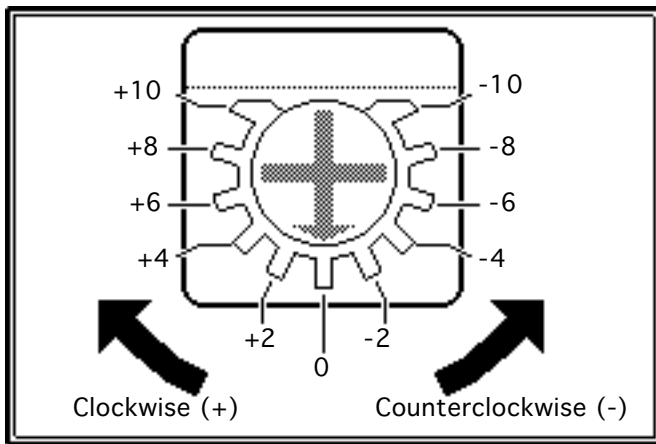

VR202

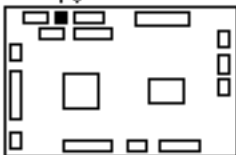

DC Controller Board

- 1 Using a jeweler's screwdriver, reset VR202 on the DC controller board to "0."
- 2 Switch on the printer and wait for the printer to warm up.
- 3 Press the service test page button three times to make three service test pages.



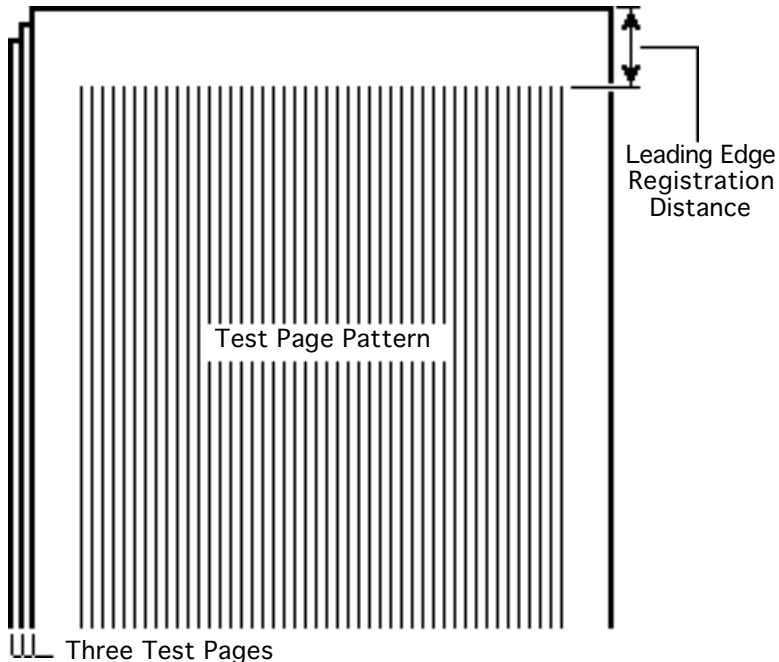

- 4 Measure the distance from the top of each page to the edge of the printed test page pattern.
- 5 Calculate the average distance by adding the three measurements and dividing by three.





(-) Counterclockwise  
(Avg. distance > 2.0 mm)

Correction Distance (mm)	VR202 Setting
-0.30	-1
-0.60	-2
-0.90	-3
-1.21	-4
-1.51	-5
-1.81	-6
-2.11	-7
-2.41	-8
-2.71	-9
-3.02	-10

(+) Clockwise  
(Avg. distance < 2.0 mm)

Correction Distance (mm)	VR202 Setting
+3.02	+10
+2.71	+9
+2.41	+8
+2.11	+7
+1.81	+6
+1.51	+5
+1.21	+4
+0.90	+3
+0.60	+2
+0.30	+1

- 6 Adjust VR202 so that the average value becomes 2.0 mm (see the table to the left).

**Note:** For example, if your average distance is 2.6 mm, the difference is 0.6 mm and you should set VR202 to a setting of +2.

- 7 Print three more test pages. If the average registration distance is not 2.0 mm, repeat this procedure.





Exploded View

---

LaserWriter Pro 600/630





# Overall Exploded View

## LaserWriter Pro 600/630 Exploded View

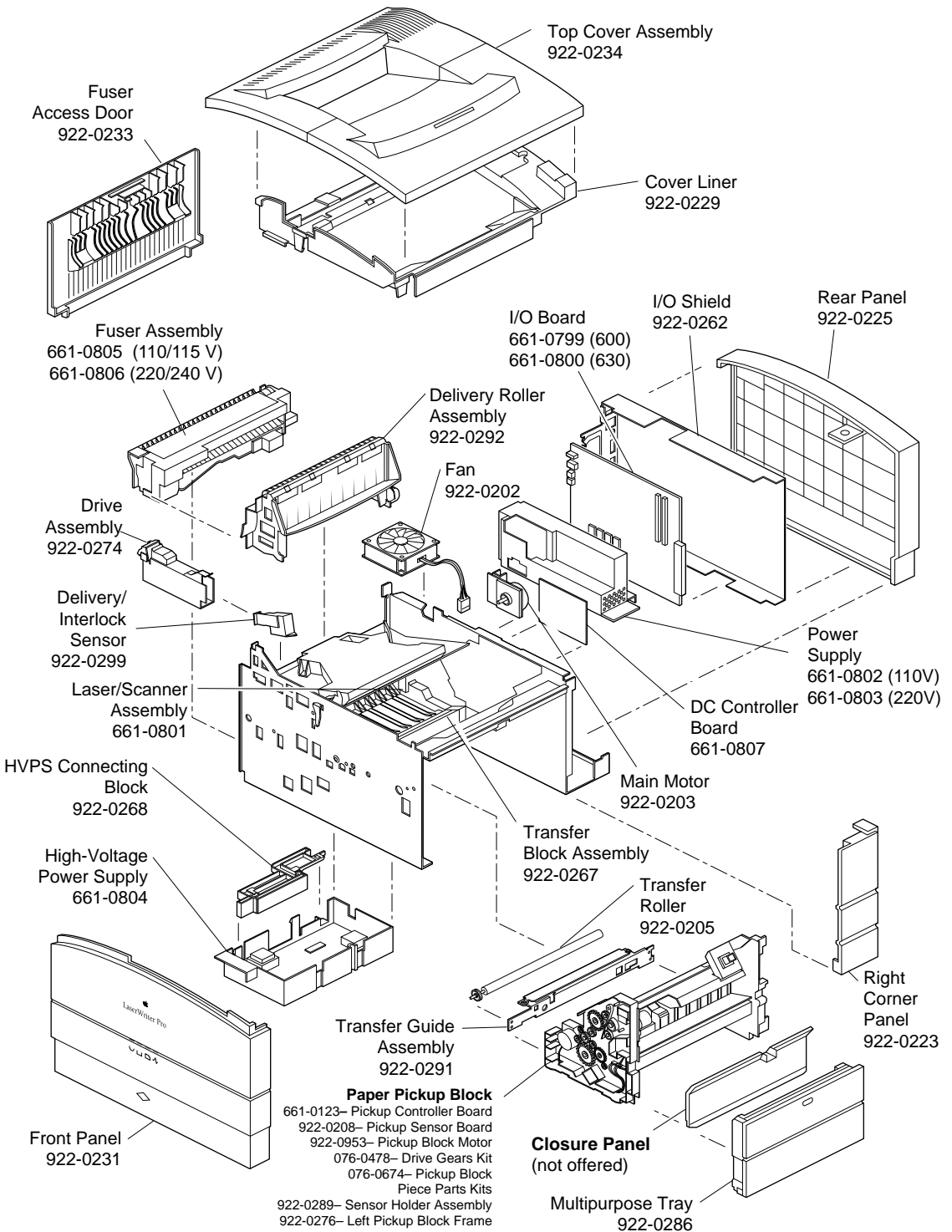

## LaserWriter Pro 600/630 Exploded View





## Delivery Roller Assembly Exploded View

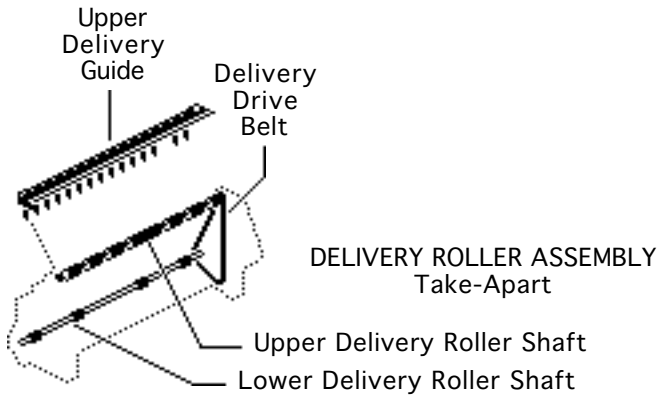



## Fuser Assembly Exploded View

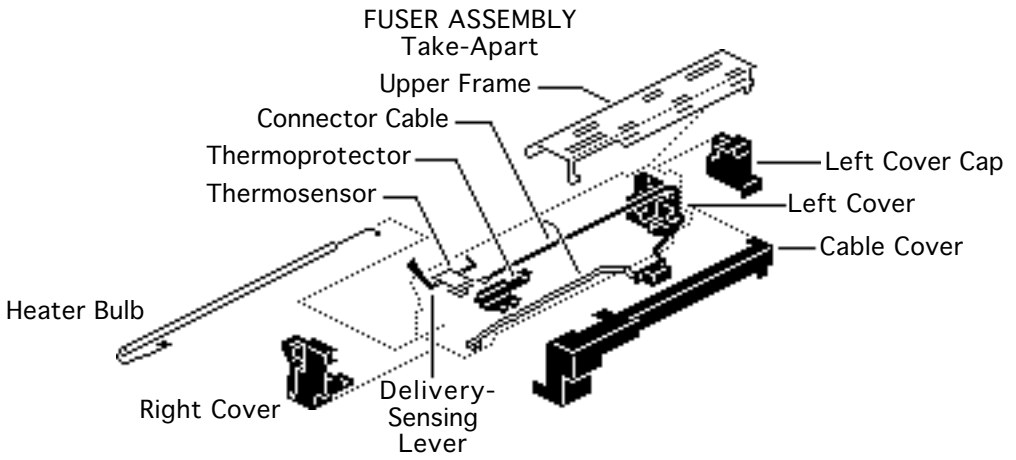



## Pickup Block Exploded View

